



# ROTARY TILLER "T" SERIES

## Operation, Service & Parts Manual



Carefully read this manual  
before using the machine

May 2007

No part of this manual shall be reproduced, copied or disseminated by any means, without manufacturer prior authorization in writing.

Gearmore reserves the right to make any necessary changes without giving prior notice, in order to optimize the quality and safety features and does not commit itself to updating this manual every time a change is made.

This booklet provides a thorough and accurate description of the instruction and maintenance activities to be carried out on the tiller you purchased. We congratulate you on your choice and urge you to thoroughly familiarize yourself with and follow the instructions contained in this manual. This will assure you a long, safe and trouble free working life for your tiller.

**Gearmore shall not assume any responsibility should problems arise as a result of lack of compliance with the instructions and/or operator's negligence.**

The manual is divided in chapters and paragraphs and the pages are numbered, thus offering accurate and precise information.

Date of Purchase: \_\_\_\_\_

Model Number: \_\_\_\_\_

Serial Number \_\_\_\_\_

# TABLE OF CONTENTS

## INDEX

### GENERAL INFORMATION

Application . . . . .	Page 1
Symbols . . . . .	Page 1
Safety labels . . . . .	Page 2
Technical data . . . . .	Page 3
Main parts terminology . . . . .	Page 4
Identification plate . . . . .	Page 5
Recommended use . . . . .	Page 5
Inappropriate use . . . . .	Page 5
Torque Specification . . . . .	Page 5

### SAFETY

Safety in the workplace . . . . .	Page 6
User's requirements . . . . .	Page 6
Work clothing . . . . .	Page 6
General safety norms . . . . .	Page 6
Preparation . . . . .	Page 7

### SET UP

Attachment to the tractor . . . . .	Page 8
PTO shaft connection . . . . .	Page 11
Working depth adjustment . . . . .	Page 12
Leveling board adjustment . . . . .	Page 13

### MAINTENANCE

Road transport . . . . .	Page 14
Shut down . . . . .	Page 14
First check . . . . .	Page 14
Every 8 working hours . . . . .	Page 15
Every 50 working hours . . . . .	Page 15
Every 500 working hours . . . . .	Page 15
Blades replacement . . . . .	Page 16

### SPARE PARTS

How to order spare parts . . . . .	Page 16
Tiller Parts Breakdown . . . . .	Page 17
Tiller Parts List . . . . .	Page 18
Gearbox Parts Breakdown . . . . .	Page 23
Gearbox Parts List . . . . .	Page 24
Driveline Assembly . . . . .	Page 25
Slip Clutch Assembly . . . . .	Page 26
Limited Warranty . . . . .	Page 27

# GENERAL INFORMATION

## GENERAL INFORMATION

### APPLICATION

The T Series Rotary Tillers are designed to till soil for seedbed or planting preparation. The T Series Tillers are adapted for tractors with 540 and 1000 rpm PTO speeds and Category 2, 3-point hitch tractors up to 160 HP.

### SYMBOLS

This booklet contains three "safety pictograms" which highlight the relevant danger levels or important information:



It draws the operator's attention to special situations which may jeopardize people's safety.

---



It draws the attention to situations which unfavorably affect the machine efficiency, but not people's safety.

---



It is used for general information, when people's safety or the efficiency of the parts are not at risk.

---

# SAFETY LABELS

## SAFETY LABELS

The safety labels and information on the machine (labels 1, 2 and 3), must be complied with. Failure to comply with these warnings may result in severe injuries or even death. Make sure that the labels are always present and legible; should this not be the case, contact your nearest Gearmore dealer to request replacements

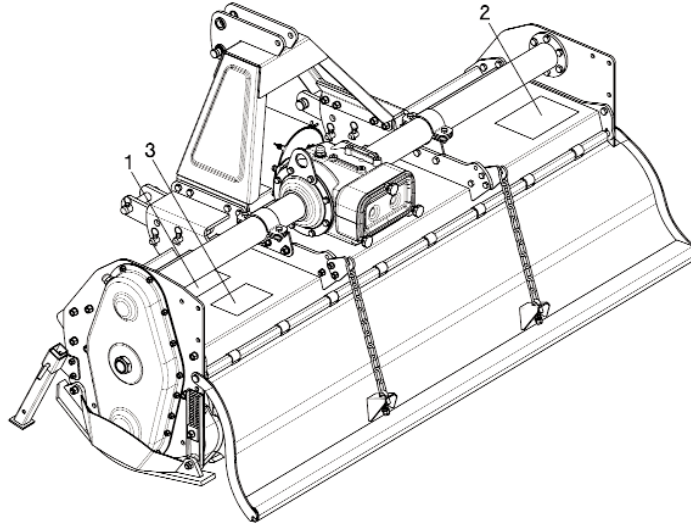

**1**

**DANGER**

1 MAKE SURE DRIVELINES ARE OF THE CORRECT LENGTH AND PROPERLY CONNECTED. DRIVELINE SEPARATION AND/OR PTO STUB SHAFT FAILURE CAN CAUSE INJURY OR DEATH. (See Operator's Manual for procedure)

2 MAKE SURE THAT DRIVELINE SHIELDS ARE INSTALLED CORRECTLY AND TURN FREELY TO AVOID INJURY OR DEATH FROM ENTANGLEMENT

3 MAKE SURE THAT DRIVELINE IS INSTALLED CORRECTLY ON TRACTOR PTO SHAFT. MOVE YOKE BACK AND FORTH UNTIL LOCKING COLLAR CLICKS FORWARD AND LOCKS YOKE IN PLACE.

4 540 PTO RPM UNLESS SPECIFICALLY MARKED OTHERWISE.

4781001

**3**

**WARNING**

SHIELDS AND DEFLECTORS MAINTAINED IN BAD CONDITION MAY CAUSE INJURY OR DEATH FROM ENTANGLEMENT WITH ROTATING PARTS, BEING HIT BY OBJECTS THROWN WITH GREAT FORCE BY BLADES, OR BY BLADE CONTACT.

- Always replace Guards which have been removed for maintenance. Never operate with guard missing or broken.
- Chain Guards, Gearbox, Drivelines Shields, eventual Rubber-fabric Deflectors, and solid band enclosures are subject to wear and lost or broken parts must be replaced or repaired as soon as damage is found.
- Safety shielding must be installed and in good condition to avoid the possibility of thrown objects when the machine is operated in any area where thrown objects could cause injury.

4781006

**2**

**DANGER**

FAILING TO FOLLOW SAFETY MESSAGES AND OPERATING INSTRUCTIONS CAN CAUSE SERIOUS BODILY INJURY OR EVEN DEATH TO OPERATOR AND OTHERS IN THE AREA.

1. READ OPERATOR'S MANUAL CAREFULLY AND PAY ATTENTION TO SAFETY DECALS FOR TRACTOR AND TILLER THOROUGHLY TO AVOID MISUSE, ABUSE, AND ACCIDENTS. PRACTICE BEFORE OPERATING.
2. OPERATE ONLY WITH ROPS AND FASTEN SEAT BELT TO AVOID INJURY AND POSSIBLE CRUSHING DEATH FROM OVERTURN. ALLOW NO RIDERS ON TRACTOR OR TILLER. FALLING OFF CAN CAUSE SERIOUS INJURY OR DEATH BY BEING RUN OVER BY TRACTOR OR TILLER OR BY BEING CUT BY THE ROTATING TILLER BLADES. ALLOW NO CHILDREN ON OR NEAR TILLER OR TRACTOR.
3. TO AVOID INJURY FROM FALLING OBJECTS WEAR HARD HAT, SAFETY GLASSES AND SHOES.
4. BLOCK UP OR SUPPORT MACHINE SEVERELY BEFORE PUTTING HANDS OR FEET UNDER, OR WORKING UNDERNEATH LIFTED PARTS TO AVOID CRUSHING INJURY OR EVEN DEATH FROM SUDDEN, INADVERTENT DROPPING. MAKING SURE AREA IS CLEAR BEFORE LOWERING.
5. BEFORE TRANSPORTING, PUT LIFT LEVER IN LIFT (DETENT) POSITION AND FOLLOW TRAFFIC CODES. SLOW DOWN AT NIGHT, IN TURNS, & ON HILLSIDES.
6. MAKE SURE THAT SMV SIGN, WARNING LIGHTS, AND REFLECTORS ARE CLEARLY VISIBLE.
7. NEVER OPERATE WITH TILLER RAISED OF GROUND TO REDUCE POSSIBILITY OF INJURY FROM OBJECTS THROWN UNDER TILLER STRUCTURE.
8. BEFORE DISMOUNTING, SECURE TILLER IN TRANSPORT POSITION OR LOWER TO GROUND, STOP PTO, PUT TRACTOR IN PARK OR SET BRAKE, STOP ENGINE, AND REMOVE KEY. NEVER MOUNT OR DISMOUNT MOVING VEHICLE TO PREVENT POSSIBLE CRUSHING INJURY OR DEATH.

4781002

# TECHNICAL DATA

## TECHNICAL DATA

Model	Tilling Width		HP	Weight (Approx.)		Working Depth (Max.)		Side Drive		Blades (Qty.)	Blades	
	cm	Inches		kg	lbs.	cm	Inches	Chain	Gear		Blades /Flange	Shape
T	230	90	90-100	930	2140	25	10		*	60	6	Curved
	280	110	100-120	1110	2205	25	10		*	66	6	Curved
	305	120	120-160	1150	2275	25	10		*	72	6	Curved



**When asking for information or technical service, always specify the machine type and width.**

# MAIN PARTS TERMINOLOGY

## MAIN PARTS TERMINOLOGY

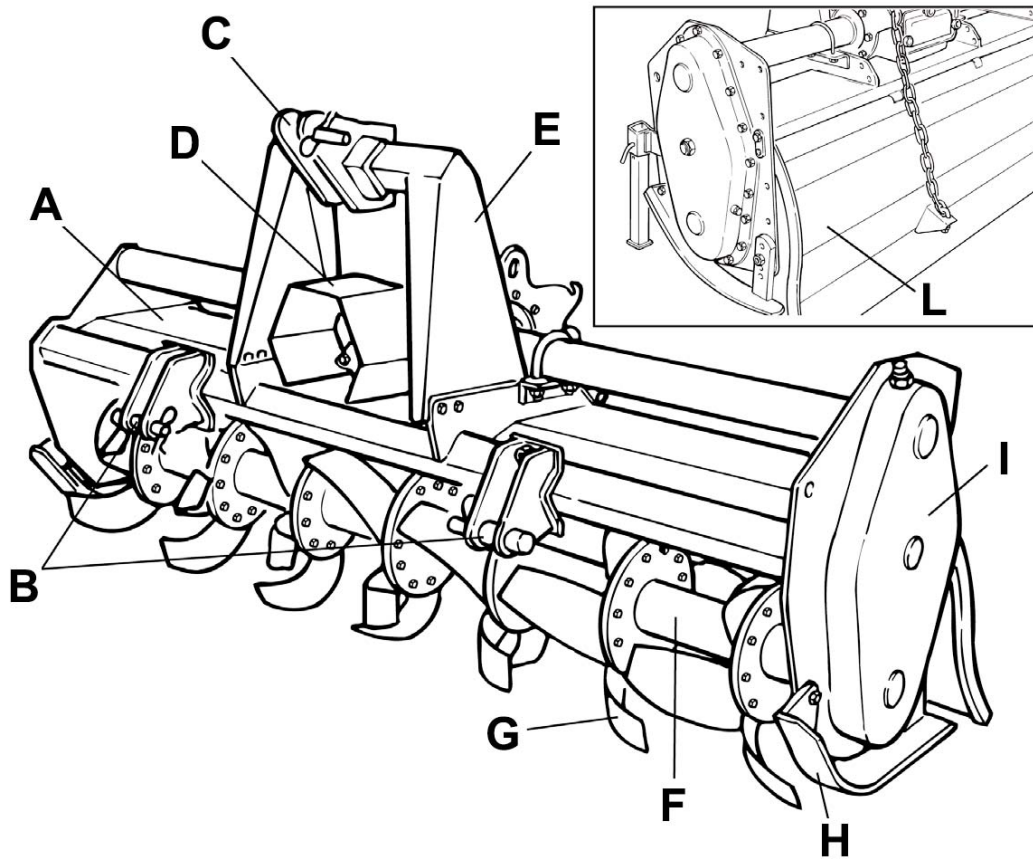

- A) Frame
- B) Lower 3-point hitches
- C) Upper 3-point hitch
- D) Cardan guard
- E) 3-point mast

- F) Rotor
- G) Tines
- H) Side skids
- I) Transmission case
- L) Cover

# INFORMATION

## IDENTIFICATION PLATE

An identification plate is placed on each tiller and is structured as follows:

Serial number (sample):



## RECOMMENDED USE

The tillers described in this instruction and maintenance manual, have been designed explicitly to till the land. Any other use jeopardizes the operator's safety and the machine integrity.

## INAPPROPRIATE USE

The tillers shall not be used as follows:

- Connected to vehicles which do not have a suitable power or weight.
- Without being properly installed by securing the hitch brackets to all three points of the tractor lift unit.
- Tilling of extremely stony or unsuitable ground.
- Raising or lifting of the equipment when the power take off is engaged.
- In close proximity to person/s when power is engaged.
- Do not stand or step on the equipment when it is being operated or transported.
- Do not operate the machinery while wearing unsuitable (loose fitting) clothing.

## TORQUE SPECIFICATIONS

For correct hardware tightening on the tiller, we suggest the use of suitable torque wrench and the applicable torque as listed in the table below:

M-THREADED SCREW/BOLTS  
Bolt grade

Thread	8.8		10.9	
	Nm	Lb-ft	Nm	Lb-ft
M6	11	8.5	17	12
M8	28	20	40	30
M10	55	40	80	60
M12	95	70	140	105
M14	150	110	225	165
M16	240	175	305	225
M18	330	250	475	350

# SAFETY

## SAFETY IN THE WORKPLACE

Most of the accidents, which occur while the operator is using the machine or the equipment or carrying out maintenance and repair activities, are caused by the non-compliance with the main safety requirements.

Therefore the potential risks must be fully understood and special attention must be paid to the activity which is being executed.

**If potentially dangerous situations are known,  
accidents can be prevented!**

## USER'S REQUIREMENTS

The equipment user must have the following:

**Physical:** good sight, co-ordination and capability to execute all instructions in a safe manner.

**Mental:** the users must understand and follow the prescribed norms, rules and safety measures. They must be careful, pay attention to their own safety and the safety of other people and act properly and in a responsible way.

**Training:** the users must read and understand this manual, its pictures and charts, and the identification and hazard plates. They must be specialized, trained and qualified on any use and maintenance activities.

## WORK CLOTHING

The following clothing and personal protective equipment must be used when working and executing maintenance and repair activities:

- Overalls or any other comfortable outfit; make sure that they are not too loose since they might be caught by moving parts.
- Protective gloves.
- Goggles or mask to protect the eyes and face.
- Safety helmet.
- Safety shoes.



**Wear only personal safety accessories in good condition and complying with the rules in force.**

## GENERAL SAFETY NORMS

The features of the area where work is taking place must always be taken into consideration:

- Do not stand in the working radius of the operating machinery or any other machine accessories when the equipment is running.

# PREPARATION

## **Prepare the work:**

- Do not drink alcohol, take drugs, or any other substances which may affect your ability to use the equipment before or when working.
- Make sure that there is sufficient fuel in the tractor to prevent the machine from stopping during work.
- Do not use the equipment under unsafe conditions, e.g. do not make temporary repairs just to start or keep working; do not work at night if the area is not well illuminated.

## **When working or executing maintenance activities, remember:**

- The labels and stickers providing instructions on the use of the equipment or information on dangers must not be removed or hidden, and must be legible.
- Do not remove the safety devices, covers and safety guards, unless maintenance activities are being carried out. If the safety devices must be removed, turn the engine off, remove them correctly and re-install them before turning the tractor on.
- Do not lubricate, clean or adjust moving parts.
- Use the appropriate tools to execute maintenance or adjustment activities on the equipment.
- Do not use damaged or unsuitable tools, e.g. pliers rather than wrenches etc.
- Prior to carrying out activities on hydraulic lines under pressure, or disconnecting their components, make sure that the line is no longer under pressure and that it does not contain any hot fluids.
- Check all the fittings and make sure that they are well connected before supplying pressure to the hydraulic lines.
- Make sure that no tools, clothes or any other materials are left in areas where moving parts are present when the maintenance and repair activities are completed.
- Do not give directions and make signals at the same time during a maneuver. Maneuver directions and signals must be given from one person only.
- Do not unexpectedly call an operator, if not necessary. Do not startle the operator, e.g. by throwing objects.
- Pay attention to people in the vicinity of the work area, especially children!
- Make sure that nobody is standing in the working range of the equipment.
- Do not use the equipment to lift people.
- When the equipment is not needed, turn the engine off, leave the vehicle on a flat surface, with the first gear and the parking brake engaged. Disengage the power take off.
- Do not execute any cleaning, lubrication, repair or adjustments when the engine is running and the equipment is in the raised position.
- Do not work on steep slopes, if the stability of the vehicle can be jeopardized.

**Manufacturer shall not assume any responsibilities if these instructions are not strictly followed.**

# SET-UP

## ATTACHMENT TO THE TRACTOR

This tiller may be attached to any tractor equipped with a Cat. 2, 3-point hitch with suitable ball ends. Before attaching the equipment to the tractor, set both on flat and smooth ground and make sure that nobody is standing between them.

### 3-POINT CATEGORY 2 HITCH

To connect the tiller to the tractor's Cat. 2, 3-point hitch, do the following operations:

- 1) Put the floating brackets in the lower position inserting the pin A in the upper hole as shown in picture 1; this gives you the standard A.S.A.E. vertical dimension of 20" (picture 2). The horizontal distance between the brackets is 32 1/2".

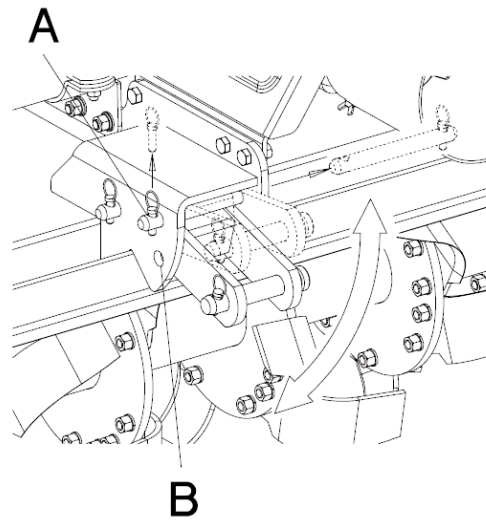

picture 1

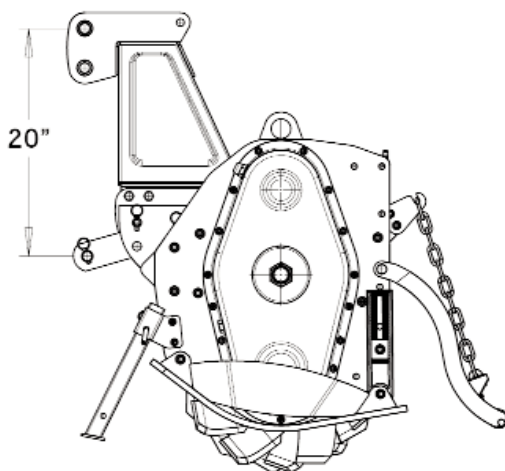

picture 2

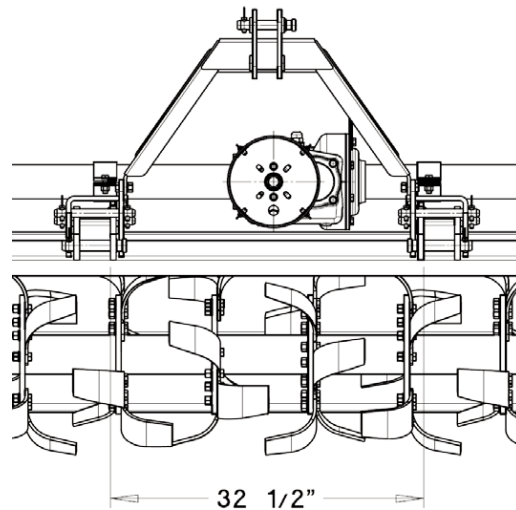

# SET-UP

- 2) Remove the cotter pins from the hitch pins (picture 3);
- 3) Remove the lower hitch pins from the lower hitch blocks (picture 3);

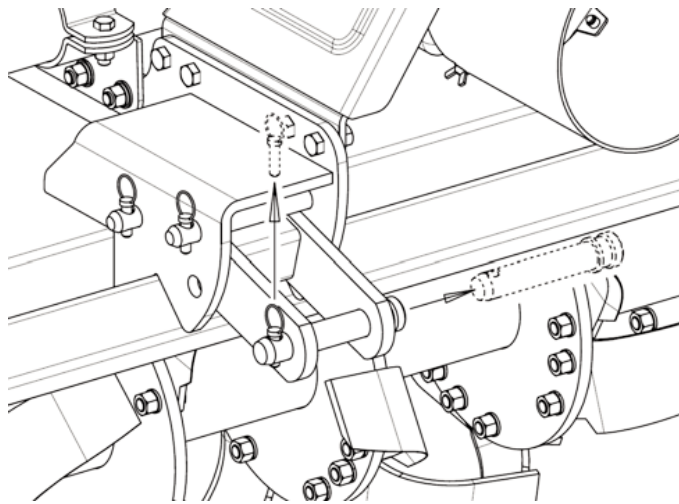

**picture 3**

- 4) Before attaching the equipment to the tractor, make sure that the ground is smooth and flat and that nobody is standing between the tractor and the tiller; slowly move the tractor towards the tiller by aligning the tractor lifter arms with the blocks' holes (picture 4); turn the engine off and pull the brake;

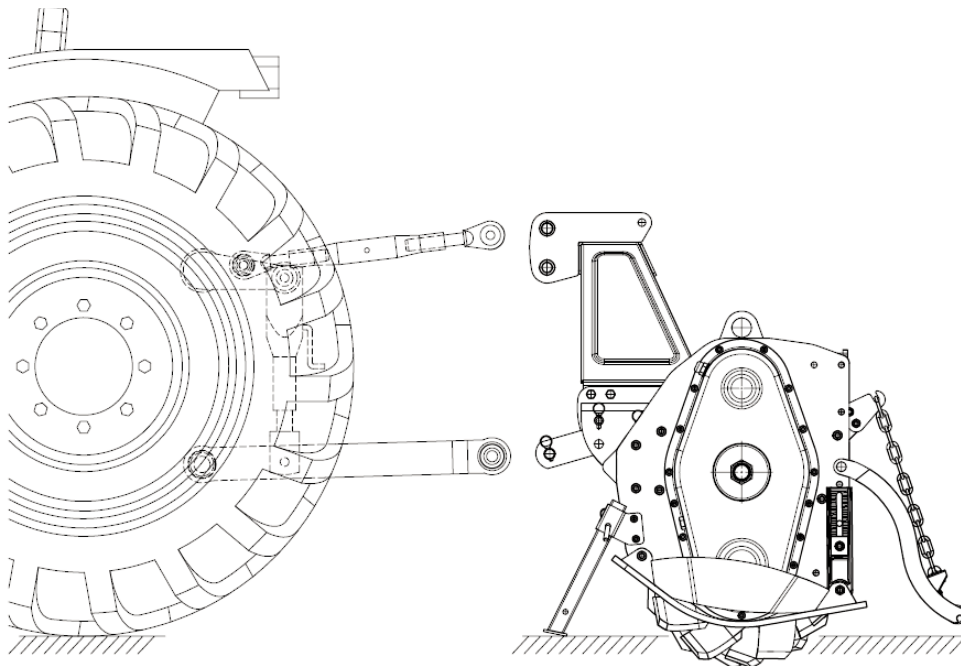

**picture 4**

# SET-UP

- 5) Insert the lower hitch pins through the hitch blocks and ball ends (picture 5);
- 6) Secure them by means of the cotter pins which were previously removed (picture 5);

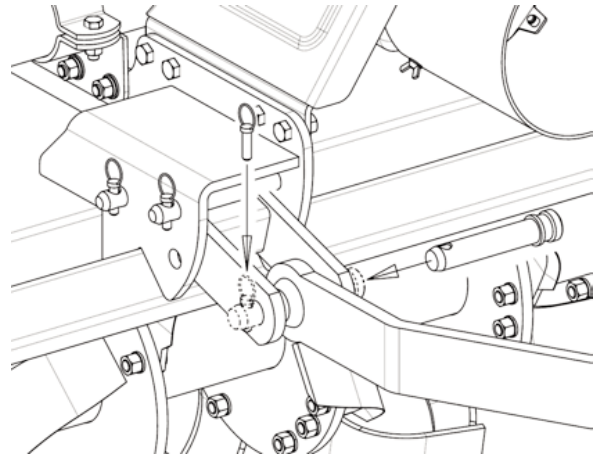

**picture 5**

- 7) Connect the tractor top link to the third upper point by removing the pin located between the two plates, inserting the top link and securing it by means of the cotter pin. Shift the parking stand in the upper position .
- 8) Adjust the top link so that the upper part of the frame is parallel to the ground. Block all the linking parts by means of the sway chains or arms.
- 9) Make sure that the central unit axis (case/bevel gear pair) is parallel to the ground, thus minimizing the stresses on the power take off and increasing the working life of the equipment.



**Caution**

**After executing all the above mentioned activities, make sure that all the nuts and bolts are tightened.**

# SET-UP

## PTO SHAFT CONNECTION

Before installing the PTO shaft make sure that the RPM rating and the direction of rotation match those of the tractor. Carefully read the PTO shaft and tractor instructions. Furthermore, accurately read the instructions of the manufacturer of the PTO shaft and of the tractor.

Before starting any activity, make sure that the guards are installed on the power take off of the tractor and PTO shaft. Make sure that they cover the PTO shaft throughout its length.

**Caution**

**When fully extended, the plastic pipes must overlap by at least 1/3 of the length of the pipes (LT). When retracted, the minimum acceptable clearance is 2" (picture 8).**

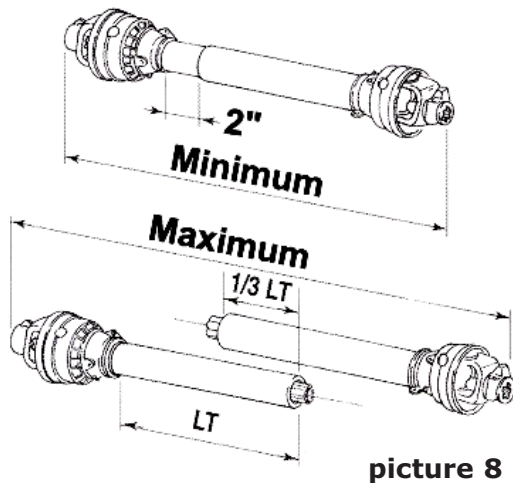

picture 8

Check that the PTO shaft minimum and maximum length are within the parameters of the machine tractor coupling.

Should problems arise, contact your dealer. After the installation, anchor the PTO shield to the tractor and machine using the special chains; make sure that it turns smoothly. If the PTO shaft is equipped with safety devices, e.g. torque limiters or free-wheel devices, install them on the operative machine side. For the use and maintenance of the PTO shaft, please refer to the relevant manual.

## COVER ADJUSTMENT

The rear cover can be adjusted in height to better compact the ground and make it flat. The adjustment can be made by releasing chain **A** (picture 9) from upper hook **B** and inserting it back to the needed height.

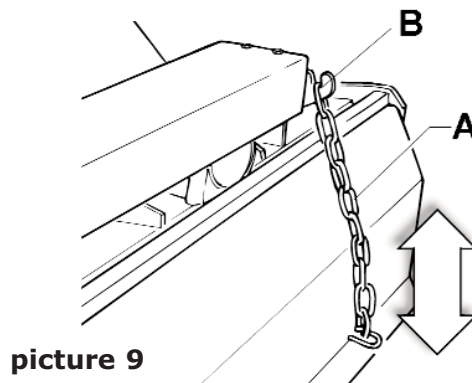

picture 9

**Danger**

**These operations shall be made only on working ground and only after having stopped the engine, disengaged the power takeoff and pulled the parking brake. If necessary, lift the machine from the ground but, in order to avoid risks for people, place it on supports thus preventing any injuries that might be caused by its sudden fall.**

# SET-UP

## WORKING DEPTH ADJUSTMENT

The working depth of the equipment depends on the position of the lateral skids. If the skids are raised, the working depth increases; if the skids are lowered, the working depth decreases.

To adjust the working depth, loosen nut **A**, **B**, and **C** (picture 10) and adjust the skid height according to the notches **D**.

When the adjustment is completed, tighten the screws to the correct torque, according to the values suggest in **Torque Specifications**, page 5.

**IMPORTANT:** Make sure that the skids are set at the same height on both sides.

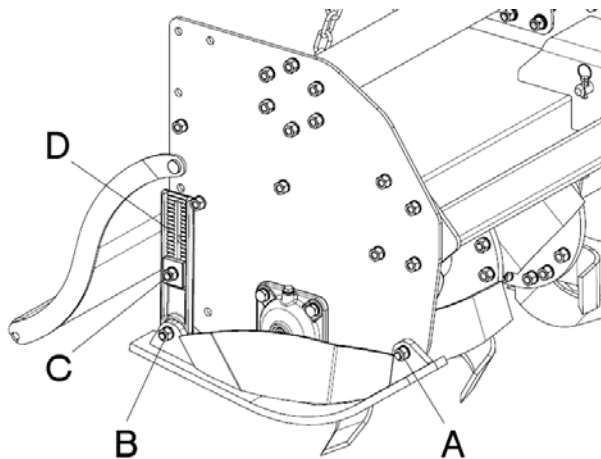

picture 10

**! Danger**

**These operations shall be made only on working ground and only after having stopped the engine, disengaged the power takeoff and pulled the parking brake. If necessary, lift the machine from the ground but, in order to avoid risks for people, place it on supports thus preventing any injuries that might be caused by its sudden fall.**

## SPEED GEAR SETUP

The Series T gearbox is provided with two pair of gears. By changing their relative position 4 different rotor speeds are achieved. Choose the desired rotor speed and follow the instructions below:

- 1) Drain the oil from the gearbox;
- 2) Remove the cover **A** unscrewing the lobe knobs **B** (see picture 11).

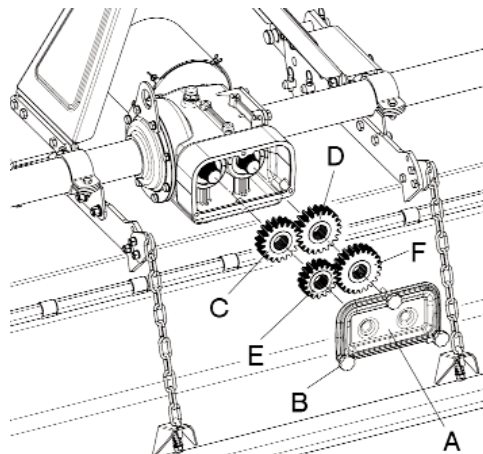

picture 11

# SET-UP

- 3) Change the position of the gears C and D according to the following table:

SETTING	C GEAR	D GEAR	ROTOR SPEED	PTO SPEED
1	17 Teeth	21 Teeth	207 rpm	540
2	16 Teeth	22 Teeth	230 rpm	540
3	22 Teeth	16 Teeth	225 rpm	1000
4	21 Teeth	17 Teeth	251 rpm	1000

- 4) Fix the remaining gears E and F on the suitable pins on the internal face of the cover;
- 5) Put back the cover in its position, tighten the screws, and fill with oil.

## LEVELING BOARD ADJUSTMENT

The rear leveling board can be adjusted in height to better compact the ground and make it flat. The adjustment can be made by releasing chains **A** (picture 12) from upper hooks **B** and inserting them back to the desired height.

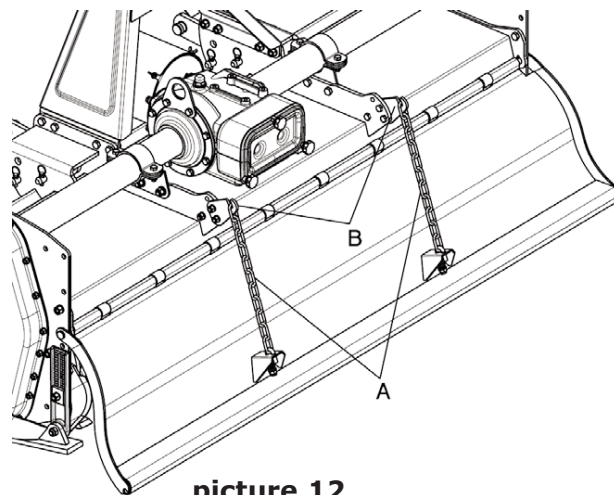

picture 12

# MAINTENANCE



These activities must be carried out with the engine off, the power take off disengaged and the hand brake applied. If needed, lift the equipment and place it on supports, thus preventing any injuries that might be caused by a sudden fall of the equipment.

## START UP

After carrying out these adjustments, the equipment is ready for use. When at the working area, do not start the power take off with the tiller in working position in the ground. Be sure to lift it by a few centimeters using the tractor lift. Start the engine, engage the power take off, lower the equipment to its working position and start.

## ROAD TRANSPORT

With reference to road transport, follow local traffic regulations.

## SHUT DOWN

The following activities are recommended if the tiller will not be used for a long period of time:

1. Clean and dry the equipment.
2. Inspect the equipment and replace the damaged or worn parts if necessary.
3. Tighten all the screws and nuts.

Lubricate and cover the machine with a tarpaulin and store it in a dry place.

## MAINTENANCE

Maintenance is crucial for the working life and efficiency of any agricultural equipment. If the equipment is properly maintained and operated, a long working life and operator safety are assured.

The maintenance intervals indicated in this booklet are provided as a mere reference and are related to normal working conditions; changes may occur depending on the type of activities, environmental dust, seasonal factors, etc.



- Before injecting lubricating grease into the grease fittings, clean the fittings to prevent mud, dust, or any other foreign matter from contaminating the grease and reducing the lubrication effect.
- When adding or changing the oil, use the same type of oil to prevent mixing oils with different features.
- All maintenance activities must be carried out with the tiller resting horizontally on the ground.
- After using the equipment for a few hours, make sure that all the bolts (especially tine bolts) are tightened; regularly check all the machine guards.

## FIRST CHECK

- After 50 working hours, change the oil in the gearbox and make sure that all the screws and bolts are tightened.

# MAINTENANCE

## EVERY 8 WORKING HOURS

- Grease the PTO shaft crosses.

## EVERY 50 WORKING HOURS

- Check the oil level in the external rotor bearing through the inspection plug **B**. If needed remove the plug **A** and add SAE EP 80W90 oil (picture 13).
- Check the oil level in the case/bevel gear pair by removing gearbox's upper oil plug (**A** - picture 14); oil level should be contained between the 2 nicks of MIN & MAX of the dip stick oil plug (**B** - picture 13). If needed add SAE EP 80W90 oil.
- Check the oil level in the side transmission (**A** - picture 15). If needed add SAE EP 80W90 oil.
- Make sure that all the screws and bolts, especially on the blades, are tightened.

## EVERY 500 WORKING HOURS

- Change the oil of the case/bevel gear pair, side transmission and rotor support; use SAE EP 80W90 oil. Contact the closest dealer for this maintenance activity.

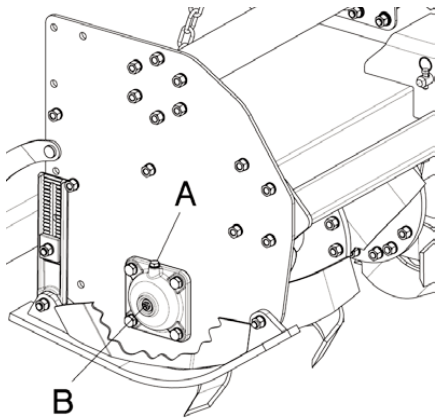

picture 13

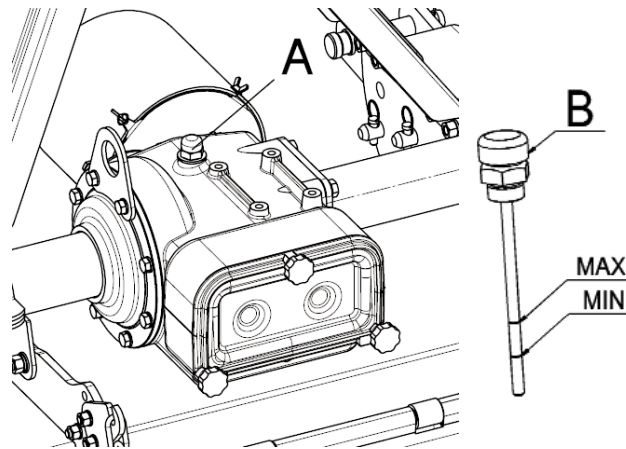

picture 14

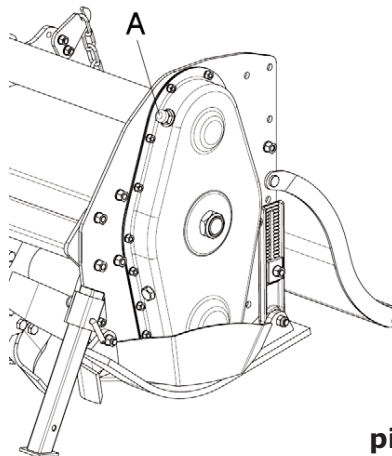

picture 15



The old oil must be disposed of in compliance with the local laws where these activities are carried out; do not spill or dispose of waste oil on the ground.

# SPARE PARTS



**Danger**

The maintenance activities must be carried out with the engine off, the power take off disengaged, the parking brake engaged, and the equipment placed on the ground.

## BLADES REPLACEMENT

To assure the optimum efficiency of the machine, make sure that the tiller blades are in a good working condition and that their bolts are tightened; replace them if they are broken or bent. The new parts must be installed in the original position.



**Danger**

Before replacing the blades, turn the tractor engine off, pull the parking brake, disengage the power take off, raise the tiller using the tractor lift, and install supports to prevent accidental dropping of the machine.

Pay special attention to the bolts **A** on the blades (picture 16): the screw head must be placed on the blade side, with the washer and the nut on the flange side, so that the bolts cannot loosen while the equipment is being used.

When several blades must be replaced, replace one blade at a time, so that the initial helical layout is maintained (picture 15).

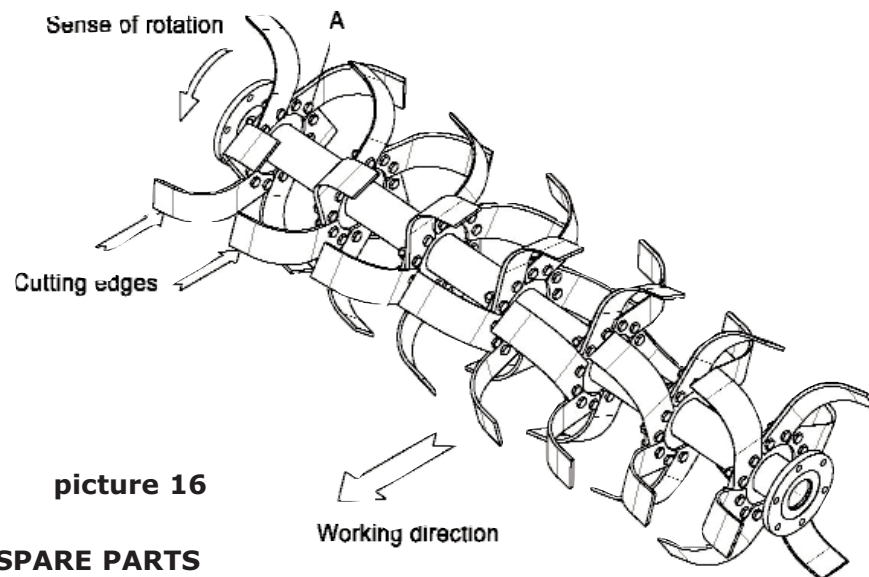

## HOW TO ORDER SPARE PARTS

For spare parts requests please refer to our spare parts catalog.

The spare parts can be ordered from the dealer or service center. The following data must always be specified:

- Equipment type and width.
- Part number of the requested component. If the code number is missing, indicate the table number in which it is shown and the relevant reference.
- Description of the part and requested quantity.
- Requested type of transport. Should this information not be provided, the dealer or service center shall not be responsible for delays caused by circumstances beyond their control. The addressee shall be responsible for any transport charges.



# TILLER ASSEMBLY

<u>REF#</u>	<u>QTY.</u>	<u>PART NO.</u>	<u>DESCRIPTION</u>
1		6350010	Shear Pin D10
2		4004088	3rd Point Upper Plate
3		4004099	Right Side Support
4		3371435	Bolt M14 x 35 x 2 UNI 5537
5		3560012	Nut M14 UNI 5587
6		3972014	Washer D14 UNI 1751
7		4304009	3rd Point Pin D25 L=138
8		3371445	Bolt M14 x 42 x 2 UNI 5537
9		4004096	3rd Point Plate (right)
10		3650010	Shear Pin D10
11		4304008	3rd Point Pin D28 L=143
12		3371440	Bolt M14 x 40 x 2 UNI 5537
13		4134011	External Side Plate
14		3972014	Washer D14 UNI 1751
15		3560012	Nut M8 UNI 5587
16		3371440	Bolt M14 x 40 x 2 UNI 5537
17		3972014	Washer D14 UNI 1751
18		3371440	Bolt M14 x 40 x 2 UNI 5537
19		6654241	Shaft Shield
20		3390820	Bolt M8 x 20 x 1.25 UNI 5539
21		3560014	Nut M14 UNI 5587
22		3972014	Washer D14 UNI 1751
23		3560014	Nut M14 UNI 5587
24		3972014	Washer D14 UNI 1751
25		4301589	3rd Point Pin D19 L=100
26		3391235	Bolt M12 x 35 x 1.75 UNI 5539
27		4004042	External Side Support T230
27		4004044	External Side Support T280
27		4004045	External Side Support T305
28		3560014	Nut M14 UNI 5587
29		3390816	Bolt M8 x 16 x 1.25 UNI 5539
30		3972008	Washer D8 UNI 1751
31		6900010	Reducer MZ-3A
32		4004098	3rd Lower Point Arm
33		4004083	Frame T230
33		4004085	Frame T280
33		4004086	Frame T305
34		4004068	External Side Skid
35		6351004	Cotter Pin D4
36		4301590	Bolck Pin D22 L=95
37		3371450	Bolt M14 x 50 x 2 UNI 5737

# TILLER ASSEMBLY

<u>REF#</u>	<u>QTY.</u>	<u>PART NO.</u>	<u>DESCRIPTION</u>
38		3972014	Washer D14 UNI 1751
39		3371455	Bolt M14 x 55 x 2 UNI 5735
40		4004097	3rd Point Plate (left)
41		4934240	Shaft Shield Support
42		3972008	Washer D8 UNI 1751
43		3560014	Nut M14 UNI 5587
44		3972014	Washer D14 UNI 1751
45		3371440	Bolt M14 x 40 x 2 UNI 5737
46		4704654	Adjusting Rod Plate
47		4644030	Skid Fixing Plate
48		4004146	Fixing Extension Support
49		4704653	Skid Adjusting Rod
50		6350010	Shear Pin D10
51		4834019	U-Bolt
52		3560014	Nut M14 UNI 5587
53		3972012	Washer D12 UNI 1751
54		3391235	Bolt M12 x 35 x 1.75 UNI 5739
55		4002330	Cover Pin T230
55		4002333	Cover Pin T280
55		4002334	Cover Pin T305
56		3391230	Bolt M12 x 30 x 1.75 UNI 5739
57		4004100	Left Support T305
58		3972014	Washer D14 UNI 1751
59		3560012	Nut M12 UNI 5587
60		4934778	Chain Hook
61		3391010	Bolt M10 x 10 x 1.5 UNI 5739
62		3972010	Washer D10 UNI 1751
63		3391025	Bolt M10 x 25 x 1.5 UNI 5739
64		3560012	Nut M12 UNI 5587
65		3972012	Washer D12 UNI 1751
66		3667012	Self Locking Nut M12
67		3972012	Washer D12 UNI 1751
68		3444014	Oil Plug M14 x 1.5
69		3560014	Nut M14 UNI 5587
70		3972008	Washer D8 UNI 1751
71		6320050	Circlip E D50
72		3391446	Bolt M10 x 45 UNI 5739
73		3972014	Washer D14 UNI 1751
74		6351004	Split Pin D4
75		3972014	Washer D14 UNI 1751
76		4004032	Shaft Support T230

# TILLER ASSEMBLY

<u>REF#</u>	<u>QTY.</u>	<u>PART NO.</u>	<u>DESCRIPTION</u>
76		4004034	Shaft Support T280
76		4004035	Shaft Support T305
77		4214060	Shaft T230
77		4214062	Shaft T280
77		4214063	Shaft T305
78		4004248	Right Bonnet T230
78		4004250	Right Bonnet T280
78		4004251	Right Bonnet T305
79		4784117	Gasket
80		6350361	Split Pin D3 L 61
81		4644005	Bearing Support
82		4784118	Bonnet Gasket
83		4644001	External Support Bonnet
84		4724004	Driving Gear Z18
85		4674003	Chain (13 chain link)
86		4302183	Chain Plate
87		4704006	Hub
88		2006310	Bearing 6310
89		2032214	Bearing 32214
90		6105590	Oil Seal 55 x 90 x 10
91		4784734	Gasket
92		4234004	Foot Pin
93		4004252	Left Bonnet T230
93		4004254	Left Bonnet T280
93		4004255	Left Bonnet T305
94		4144098	Dust Cover
95		6203911	GNL 6460 Support
96		3700045	Metal Ring D45 x 1.5
97		4004058	Foot
98		3972014	Washer D14 UNI 1751
99		3540014	Nut M14 UNI 5587
100		3950045	Washer D45
101		4212214	Spring
102		3667012	Self Locking Nut M12
103		3840045	Self Locking Metal Ring M45 x 1.5
104		3442022	Oil Plug M22 x 1.5
105		6310100	Circlip D100
106		4784116	Gasket
107		4594120	Bearing Spacer
108		3381435	Bolt M14 x 35 x 1.5 UNI 5538
109		4204064	Pin (Intermediate gear)

# TILLER ASSEMBLY

<u>REF#</u>	<u>QTY.</u>	<u>PART NO.</u>	<u>DESCRIPTION</u>
110		6800045	O Ring D 45.69 x 2.62
111		4114007	Cover
112		2030310	Bearing 30310
113		4004060	Plate
114		4004343	Rotor T230
114		4004345	Rotor T280
114		4004346	Rotor T305
115		3391435	Bolt M14 x 35 x 1.5 UNI 5739
116		2972014	Washer D14 UNI 1751
117		4004349	Normal Rotor T230
117		4004351	Normal Rotor T305
118		4814004	Right Blade
119		3391035	Bolt M10 x 35 x 1.5 UNI 5739
120		3972010	Washer D10 UNI 1751
121		3641040	Self Locking Nut M40
122		3560010	Nut M10 UNI 5587
123		3972010	Washer D10 UNI 1751
124		4724002	Intermediate Gear Z40
125		3560014	Nut M14 UNI 5587
126		3371450	Bolt M14 x 50 x 2 UNI 5737
127		3972014	Washer D14 UNI 1751
128		4814003	Left Square Blade
129		3972014	Washer D14 UNI 1751
130		3540014	Nut M14 UNI 5587
131		4814002	Right Square Blade
132		4814005	Left Blade
133		3391435	Bolt M14 x 35 x 2 UNI 5739
134		3972014	Washer D14 UNI 1751
135		3972014	Washer D14 UNI 1751
136		3560014	Nut M14 UNI 5587
137		3101440	Bolt M14 x 40
138		6200750	GNL 0750 Support
139		4724008	Hub
140		3371440	Bolt M14 x 40 x 2 UNI 5737
141		4704009	Gear Support
142		4004067	Skid
143		3371450	Bolt M14 x 50 x 2 UNI 5737
144		4724003	Driving Gear Z27
145		4784635	Gasket
146		3972014	Washer D14 UNI 1751
147		3641050	Self Locking Nut M50

# TILLER ASSEMBLY

<u>REF#</u>	<u>QTY.</u>	<u>PART NO.</u>	<u>DESCRIPTION</u>
148		3972010	Washer D40 UNI 1751
149		3391030	Bolt M10 x 30 x 1.5 UNI 5739
150		3371455	Bolt M14 x 55 x 2 UNI 5737
151		2821312	Bearing 21312
152		4004008	Rotor For Knives T230
152		4004010	Rotor For Knives T280
152		4004011	Rotor For Knives T305
153		4814514	Right Shaped Blade
154		4814515	Left Shaped Blade
155		3101445	Bolt M14 x 45
156		4004170	Teeth Holder Rotor T230
156		4004172	Teeth Holder Rotor T280
156		4004173	Teeth Holder Rotor T305
157		3371060	Bolt M10 x 60 x 1.5 UNI 5737
158		3667010	Self Locking Nut M10
159		3932010	Flat Washer D10 UNI 6592
160		6310130	Circlip D130
161		4844006	Tooth
162		3441022	Plug M22 x 1.5

# GEARBOX ASSEMBLY

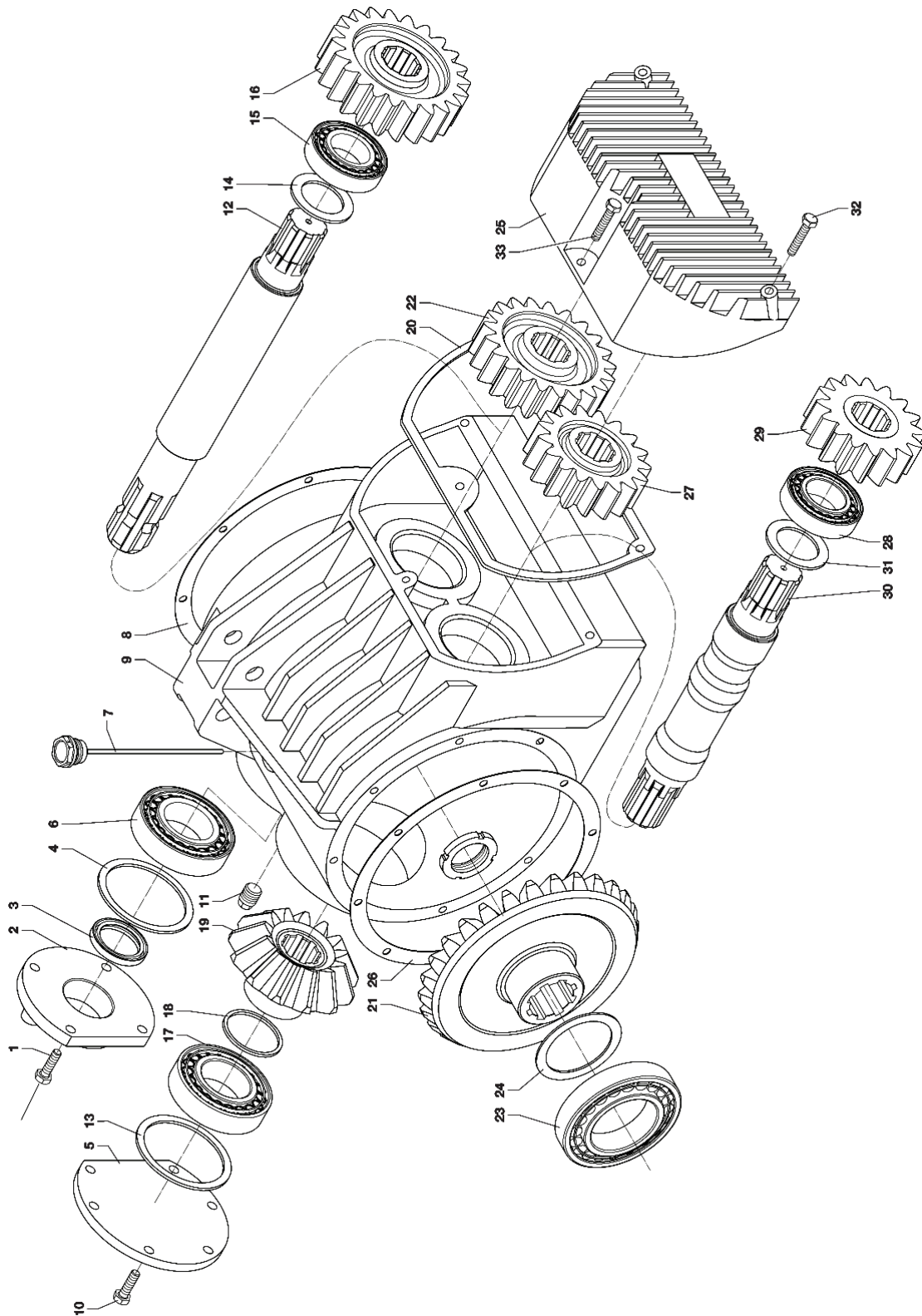

# GEARBOX ASSEMBLY

<u>REF#</u>	<u>QTY.</u>	<u>PART NO.</u>	<u>DESCRIPTION</u>
1		8.1.1.00073	Bolt M10 x 30 x 1.5 UNI 5739
2		0.717.1326.00	Open Cover
3		8.7.3.00398	Oil Seal 35 x 65 x 10
4		0.703.7500.00	Thickness D85.3 x 99.7
5		0.703.1300.01	Closed Cover
6		8.0.9.00107	Tapered Roller Bearing 30309
7		0.703.7114.00	Oil Level Charge Plug
8		0.250.7200.00	Gasket
9		0.703.0301.01	Gearbox
10		8.1.1.00061	Bolt M10 x 25 x 1.5 UNI 5739
11		8.6.5.0006	Oil Plug 3/8" Gas
12		0.703.2009.00	Shaft 1 3/4"
13		0.703.7500.00	Thickness D85.3 x 99.7
14		0.252.7200.00	Thickness D45.3 x 65.3
15		8.0.9.00125	Tapered Roller Bearing 32209
16		0.703.5016.02	Gear Z22
17		8.0.9.00124	Tapered Roller Bearing 32211
18		0.113.7500.00	Thickness D55.3 x 61.7
19		0.703.5202.00	Bevel Pinion Z13
20		0.703.7202.01	Gasket
21		0.703.6202.00	Ring Bevel Gear Z28
22		0.709.5027.02	Gear Z21
23		8.0.9.00184	Tapered Roller Bearing 30214
24		0.249.7500.00	Thickness
25		0.703.1401.00	Cover
26		0.250.7200.00	Gasket
27		0.706.5024.02	Gear Z17
28		8.0.9.00125	Tapered Roller Bearing 32209
29		0.703.5015.02	Gear Z16
30		0.703.3007.02	Intermediate Shaft
31		0.252.7500.00	Thickness D45.3 x 65.3
32		8.1.7.00126	Bolt M8 x 40 UNI 5449
33		8.1.7.00121	Bolt M8 x 25 UNI 5449

# DRIVESHAFT ASSEMBLY

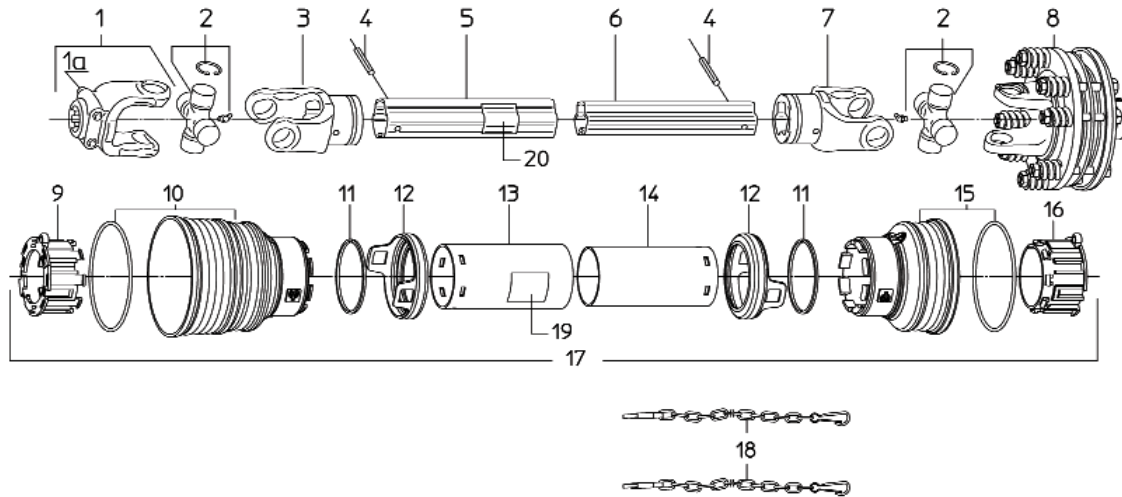

<u>REF#</u>	<u>QTY.</u>	<u>PART NO.</u>	<u>DESCRIPTION</u>
1	1	1028010	Yoke Assembly
1A	2	1581038	Push Pin Kit
2	2	1008020	Cross Assembly
3	1	1708067	Outer Tube Yoke
4	2	6331090	10 x 90 Elastic Pin
5	1	1818055	Outer Tube
6	1	1817055	Inner Tube
7	1	1708069	Inner Tube Yoke
8	1	1448032	Torque Limiter
9	1	1788010	Tube Bearing Outer Tube
10	1	1788003	Standard Cone
11	2	1218035	Stop Ring
12	2	1888009	Safety Coupling
13	1	1778044	Outer Tube Shield
14	1	1879044	Inner Tube Shield
15	1	1788002	Short Cone
16	1	1788011	Tube Bearing Inner Tube
17	1	90SS8044	Complete Protection
18	2	1006065	Anti-Rotation Chain
19	1	1140010	Outer Decal
20	1	1140011	Inner Decal

# SLIP CLUTCH ASSEMBLY

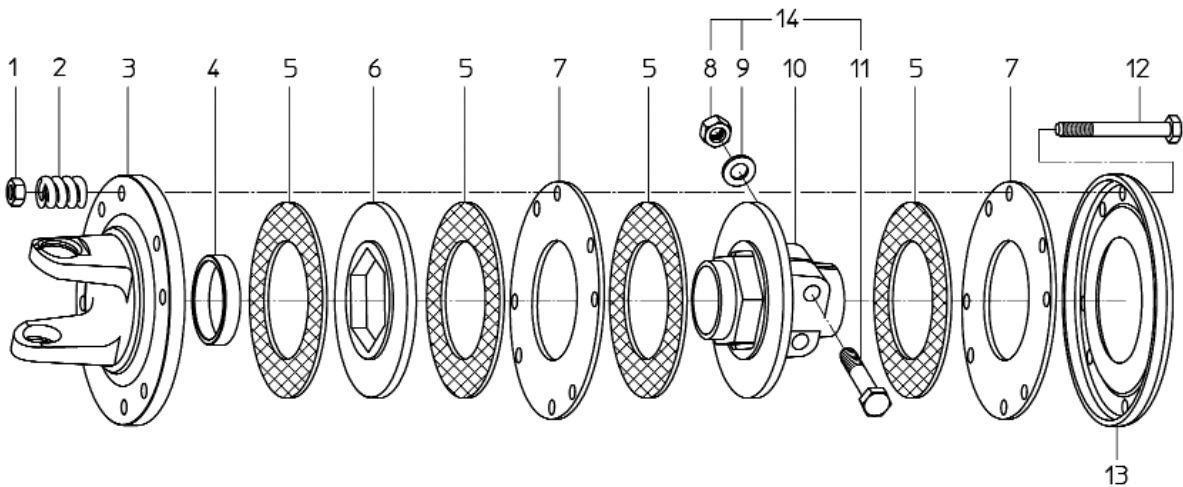

<u>REF#</u>	<u>QTY.</u>	<u>PART NO.</u>	<u>DESCRIPTION</u>
1	8	6411010	Lock Nut
2	8	1215012	Spring
3	1	1708006	Flange With Yoke
4	1	1705009	Bushing
5	4	1808010	Friction Disc
6	1	1708034	Middle Plate Hex
7	2	1138008	Inner Plate Round
8	2	6410114	Screw Nut
9	2	6412114	Spring Washer
10	1	1708019	Hub With Flange
11	2	6141480	Bolt
12	8	6001010	Bolt For Spring
13	1	1138007	Cover Plate
14	2	6761480	Locking Bolt Kit

# LIMITED WARRANTY



GEARMORE, INC., warrants each new Gearmore product to be free from defects in material and workmanship for a period of twelve (12) months from date of purchase to the original purchaser. This warranty shall not apply to implements or parts that have been subject to misuse, negligence, accident, or that have been altered in any way.

Our obligation shall be limited to repairing or replacement of any part, provided that such part is returned within thirty (30) days from date of failure to Gearmore through the dealer from whom the purchase was made, transportation charges prepaid.

This warranty shall not be interpreted to render us liable for injury or damages of any kind or nature, direct, consequential or contingent, to person or property. This warranty does not extend to loss of crops, loss because of delay in harvesting or any other expenses, for any other reasons.

Gearmore in no way warrants engines, tires, or other trade accessories, since these items are warranted separately by these respective manufacturers.

Gearmore reserves the right to make improvements in design or changes in specification at any time, without incurring any obligations to owners or units previously sold.

GEARMORE, INC.  
13477 Benson Ave.  
Chino, CA 91710

Always refer to and heed machine operating warning decals on machine.

*The serial number of this product is stored in our computer database, thus submitting a warranty registration card is not required.*