



# **HAMMER KNIFE FLAIL MOWER SHREDDER**

**Operation, Service,  
& Parts Manual  
For Models:  
GRF69, 79, 89, 98, & 108  
Fixed Center Mount**

March 2006 Rev. 2009

# TABLE OF CONTENTS

Installation .....	1
Safety Information .....	2
Lubrication .....	3
Pre-operation Check List .....	4
Mower Adjustments .....	5 - 6
Roller Height Control .....	7
Drive Belt Tension Adjustment .....	8
Troubleshooting .....	9
Safety Precautions .....	9
Deck Assembly .....	10 - 11
A-frame Assembly .....	12 - 13
Optional Rake Hatch Assembly .....	14
Rotor Shaft Assembly .....	15 - 16
Quantity Matching Chart .....	17
Roller Assembly .....	18 - 19
Tailwheel Assembly .....	20
Drive Assembly .....	21
Gearbox Assembly .....	22 - 23
Driveline Assembly GRF69, 79, & 89 .....	24 - 25
Driveline Assembly GRF98 & 108 .....	26 - 27
Limited Warranty .....	28

Date of Purchase:\_\_\_\_\_

Model Number:\_\_\_\_\_

Serial Number:\_\_\_\_\_

# INSTALLATION

## BEFORE ATTACHING THE MOWER TO THE TRACTOR

1. Make sure that the mower is suitable for your tractor's horsepower.

<u>MODELS</u>	<u>YOUR TRACTOR'S MAX. H.P.</u>
---------------	-------------------------------------

All Models	85
------------	----



**CAUTION:** Please note that if these limits are exceeded, it will invalidate your warranty.

2. Make sure the lower links and top link on the 3-point hitch arms of your tractor are the correct size (Cat. 2 only), so that they correspond to the size of the hitch on the mower you have purchased. (*Note: Optional Cat. 1 lift pins are available, see page 13*)

3. ***P.T.O. Installation:***

First, connect the P.T.O. shaft to the tractor. With the shaft in its shortest position, there should be about a 2" clearance between the end of the gearbox shaft and the end of the P.T.O. shaft. Should it be necessary to shorten the P.T.O. shaft, shorten both male and female shafts equally, keeping the protective tube covers 1" shorter than the steel tubes.

Particular attention should be given to carefully removing all burrs and to clean and lubricate the steel tubes and protective covers. There must be sufficient telescopic movement so that the two tubes do not touch the end of the P.T.O. shaft.

It is most important to carefully raise and lower the mower with the tractor hydraulic system, making sure that the P.T.O. shaft does not bottom or disengage the telescopic shaft tubes, otherwise damage may occur.

# SAFETY INFORMATION



## OPERATIONAL SAFETY:

- ❑ Guards and safety shields are for your protection. **DO NOT** operate equipment unless they are in place.
- ❑ Always operate tractor PTO (power-take-off) at recommended RPM (revolutions per minute).
- ❑ Disengage tractor PTO and shift into neutral before attempting to start engine.
- ❑ Read and observe all safety decals on the tractor and mower.
- ❑ **NEVER** allow anyone within 25' of machine while it is in operation.
- ❑ **DO NOT** stop or start suddenly when going uphill or downhill. Avoid operation on steep slopes.
- ❑ Be alert for holes in terrain and other hidden hazards. Always drive slowly over rough ground.
- ❑ Reduce speed on slopes and in sharp turns to prevent tipping or loss of control. Be careful when changing direction on slopes.
- ❑ Stop mower and tractor immediately upon striking an obstruction. Turn off engine, inspect mower and repair any damage before resuming operation.
- ❑ Disengage power to mower and stop engine before dismounting from tractor, before making any repairs or adjustments, transporting or unclogging mower.
- ❑ Take all possible precautions when leaving tractor unattended: Disengage PTO, lower mower, shift into neutral, set parking brake, stop engine and remove key from ignition.
- ❑ Front tractor weights or front tire ballast should be used to enhance front end stability on small tractors.
- ❑ Check to make sure PTO is properly connected and that the driveline is correct to prevent bottoming out or pulling apart during the full lift range of the hitch.
- ❑ This implement is designed for a one-man operation. It is the responsibility of the tractor operator to see that no one is in the proximity of the implement when it is started. **DO NOT** operate the implement with another person within 25' of the implement.
- ❑ **NEVER** operate mower with hatch in the wrong working position.
- ❑ **NEVER** run mower with rotorshaft out of balance.

# LUBRICATION



**Grease all fittings according to the following schedule:**

1. **ROLLER (Ref. 1):** Grease at both ends *after 4 hours* of operation, until grease is visible..
2. **CUTTING SHAFT (Ref. 2):** Grease at both ends lightly *after 8 hours* of operation.  
DO NOT overgrease.
4. **EXTENSION SHAFT (Ref. 3):** Grease extension shaft bearing *every 40 hours*.
3. **P.T.O. SHAFT:** The universal joints and overrunning clutch (option) need to be greased *every 8 hours*. The telescopic tubes should be greased *every 16 hours* and the shield retaining bearing should be greased *every 40 hours*.

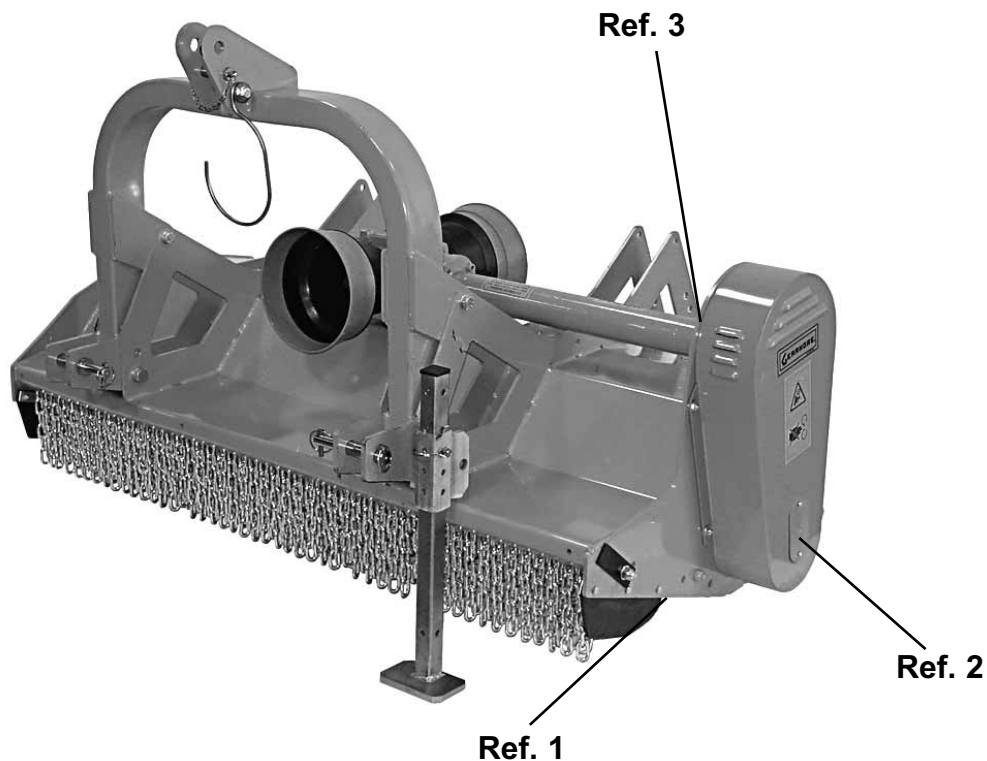

# PRE-OPERATION CHECK

- ✓ Check tightness of all bolts and nuts.
- ✓ Check gearbox oil level (Grade SAE80W-90 gear oil).
- ✓ Grease all points, on all GRF mowers.
- ✓ P.T.O. (power take-off) speed should not exceed shredder's rated RPM (revolutions per minute).
- ✓ Check correct length of P.T.O. shaft. When fitted, there should be 3 3/4" free travel on male and female tubing (check in fully raised and fully lowered positions).
- ✓ The recommended cutting height, with the hammer or blade in its lowest position, is between 2" and 4" (*Ref. 1*). Basically, the fine height adjustment is achieved with the top link of the 3-point hitch. For a greater height adjustment, it is necessary to raise or lower the roller (*Ref. 2*).
- ✓ Drive belt should flex 3/8" (1 cm.) when pushed firmly with the finger.
- ✓ Mower should be completely cleaned after use and before storage.

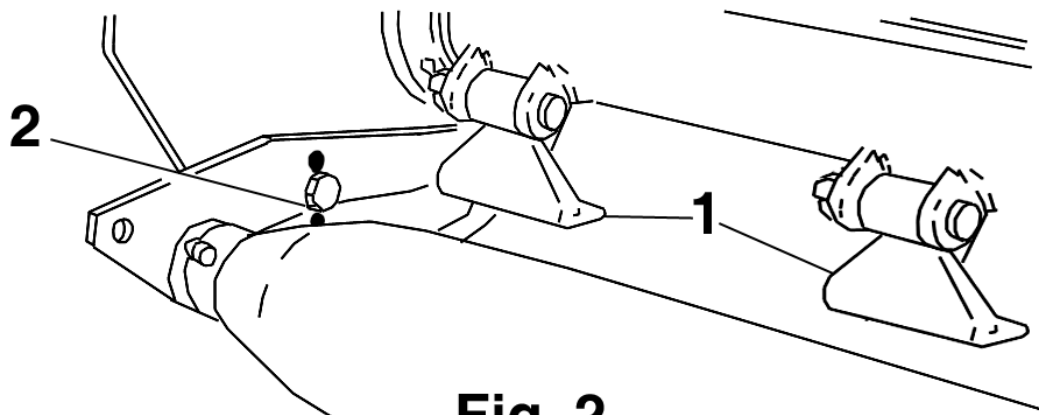

**Fig. 2**

# MOWER ADJUSTMENTS

## FOR VARIOUS TYPES OF MOWING

There is an adjustable rear hatch (*Fig. 3*) that can be set in one of seven positions to control the amount of power needed to do the work.

### FOR BEST MOWING OPERATION, OPEN REAR HATCH FULLY TO ALLOW MATERIAL TO EXIT

1. Adjustment of the rear hatch can be made by removing the two bolts at the side (*Fig. 13, ref. 1*). Loosen the nut (*Fig. 13, ref. 2*) until the hatch can be pivoted around bolt (*Fig. 13, ref. 3*). To fix the hatch in the desired position, align the hole in the side of the casing of the machine with the appropriate hole in the hatch. Insert the bolt and tighten the self-locking nut (*Fig. 13, ref. 1*). Tighten the pivot bolt (*Fig. 13, ref. 3*) with the self-locking nut (*Fig. 13, ref. 2*).

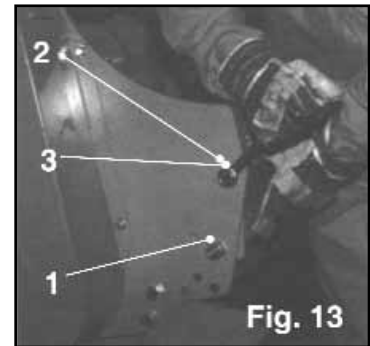

2. The rear hatch should be in a completely closed position (*Fig. 4*) when used for mulching of prunings, or pulverizing debris.
3. The hatch is used in position (*Fig. 5*) to allow the grass clippings to escape above the roller.
4. The hatch should be in a completely open position when the mower is used for grass, cover crop, weed abatement, vegetables, corn stalk and cotton cutting operations (*Fig. 6*). An open hatch enables the clippings to be discharged quickly, thus allowing a faster mowing speed and lower H.P. requirements.



**DANGER:** When the hatch is in the fully open position, objects may be thrown out of the machine. Make sure that **NO ONE** is in the operation area.

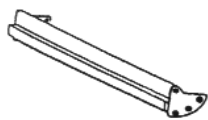

Fig. 3

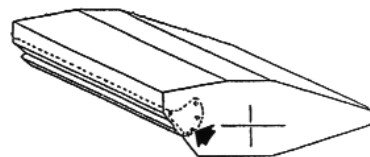

Fig. 4

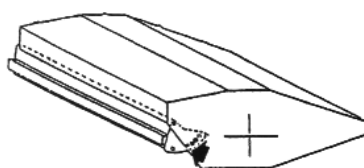

Fig. 5

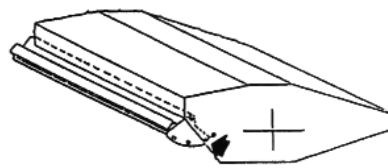
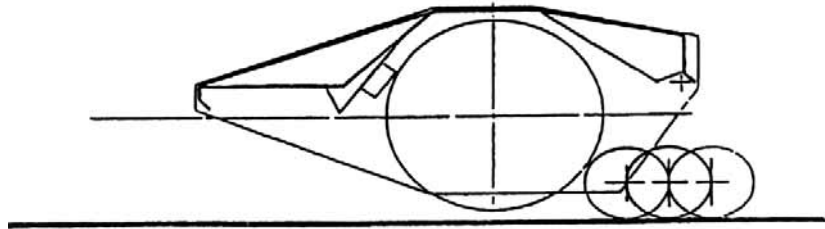

Fig. 6

# MOWER ADJUSTMENTS

1. Various roller adjustments  
3 positions



2. Used for mulching  
of prunings

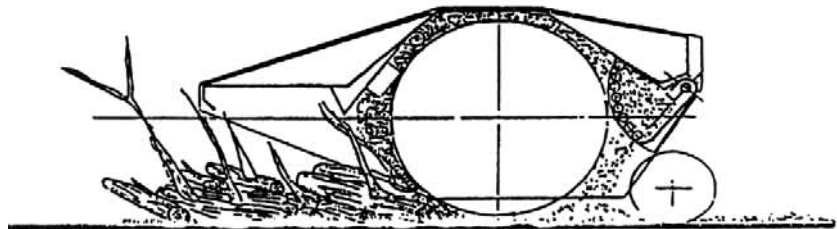

3. Used with rakes  
to mulch prunings

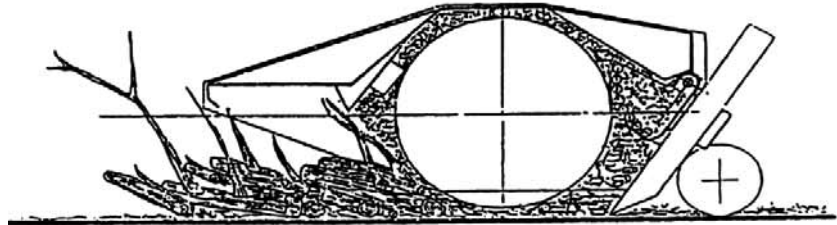

4. Used for cutting  
grass

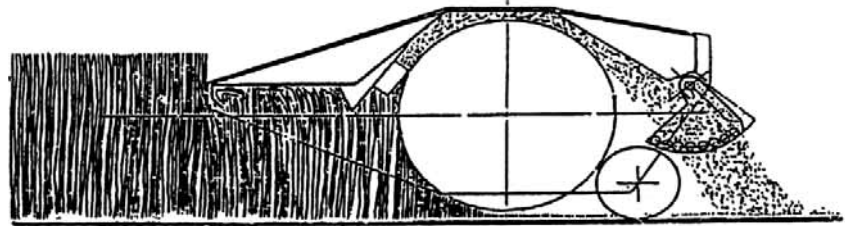

5. Used to mulch  
cornstalk

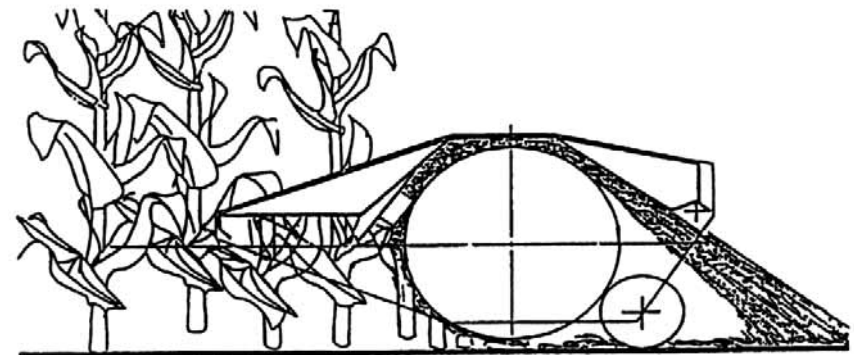

# ROLLER HEIGHT CONTROL

The roller can be adjusted for 2 or 3 cutting heights. By raising the roller, you get a shorter cut, by lowering it, a longer cut is achieved. You can also fine adjust the cutting height with the top link arm. By shortening the link arm, your cut is further from the ground.

A suggested cutting height is having the hammer tips about 2" from the ground.

You can control the power needed and the amount of wear on the hammers by this adjustment.

## ADJUSTING REAR ROLLER:

To adjust roller, loosen (*Fig. 1, ref. 1*). Completely remove (*Fig. 1, ref. 2 & 3*). Align the appropriate hole in the support bracket with the hole in the deck to achieve roller position desired.

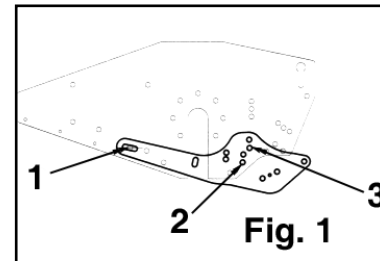

1. There is also an adjustment that can be made on the roller to control mulch size and power needed. By moving the roller toward the cutting shaft (*Fig. 7*), a finer mulch is produced, requiring less H.P. In this case, we suggest opening the hatch to cut grass, vegetables, cornstalk, cotton, etc.
2. By moving the roller away from the cutting shaft (*Fig. 7*), a coarser mulch is produced, requiring more H.P. In this case, we suggest closing the hatch to mulch prunings.
3. The third position, or furthest from the cutting shaft, is used only to allow room for rakes on the mower, if needed. Rakes are used when the prunings are laying close to the ground and have to be drawn out.
4. For more precise work and performance, we recommend spending 5 minutes adjusting your mower for the job, this can be done according to the previous recommendations.
5. The roller scraper can be removed when cutting grass, because close positioning of the roller to the cutting shaft permits the hammers to act as a roller cleaning device.

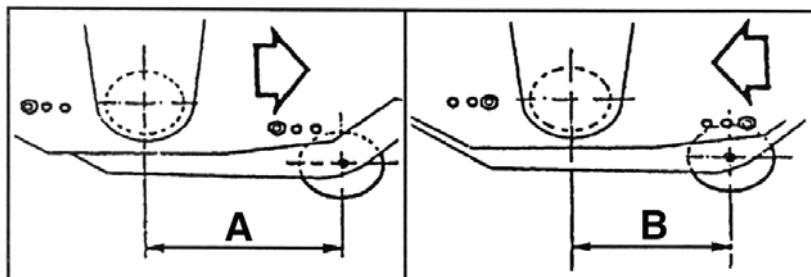
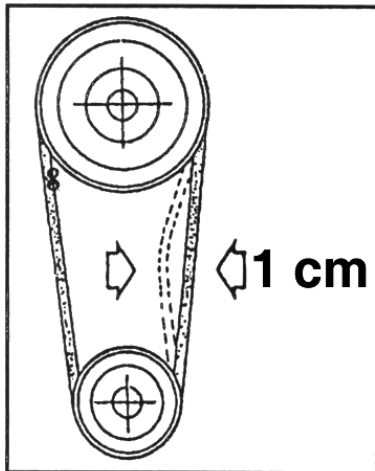

Fig. 7

# DRIVE BELT TENSION ADJUSTMENT

1. Check belt tension before each use (*Fig. 8*). The tension is correct when you can depress one belt 1 cm ( $3/8$ " ) between the two pulleys. It is possible for you to insert a tool through the belt cover (*Fig. 9*), with mower stopped, to check the tension.
2. To adjust the belt tension, loosen bolts 1, 2, 3 & 4 and locknut 6 (*Fig. 9*). To adjust tension, move bolt 5. Do not forget to tighten all bolts after correct belt tension is achieved. If a belt requires replacement, replace all other belts as well.



**Fig. 8**

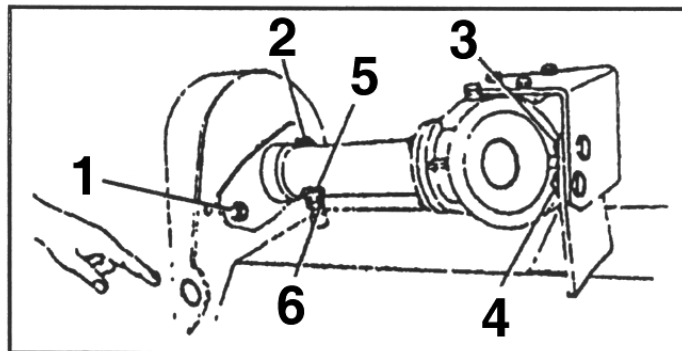

**Fig. 9**

# TROUBLESHOOTING

1. Cutting shaft does not rotate properly:
  - a. Tighten drive belts to correct tension (*see page 8*).
  - b. Replace belts if they no longer can be adjusted properly.
2. Mower vibrates:
  - a. Check for loose or missing hammers or bolts.
  - b. Check for hammers that are unevenly worn. If one or more hammers is badly worn, replace all the hammers the first time. Keep the hammers that are in good shape for future replacement in worn series of hammers. For example: when replacing a worn hammer, replace it with a hammer of similar shape and weight. This will insure a balanced and vibration free cutting.
3. If the cutting shaft becomes jammed, reverse the rotation of the shaft to loosen and release the obstruction.
4. If the hammer mounting ears break off, they must be welded back in their exact position, otherwise the cutting shaft will be unbalanced.
5. If you have any questions or problems, it is always best to contact your dealer immediately.
6. When ordering spare parts, you must contact your authorized Gearmore dealer for original replacement parts. When doing so, please include the following information:
  - a. Model Number
  - b. Serial Number

## SAFETY PRECAUTIONS

1. All adjustments, inspections and repairs must be made with tractor and mower completely stopped.
  - a. When the mower is in operation, make sure that there is no one near the flying debris from the mower, to prevent the possibility of serious injuries.
  - b. **ALWAYS** keep hands and feet away from a mower that is in operation.
  - c. Check that all guards and safety features are in place and in good operating condition.
2. While mowing, take the necessary precautions to insure operator's and others safety.
3. **DO NOT** make height adjustment using only the top link. This will cause flying debris to come out the front of the mower and toward the operator. Use the roller adjustment.

We thank you again for your choice of mowers and we remind you that the safety points outlined in this manual will help you do your work in a safe and efficient manner.

# GRF DECK ASSEMBLY

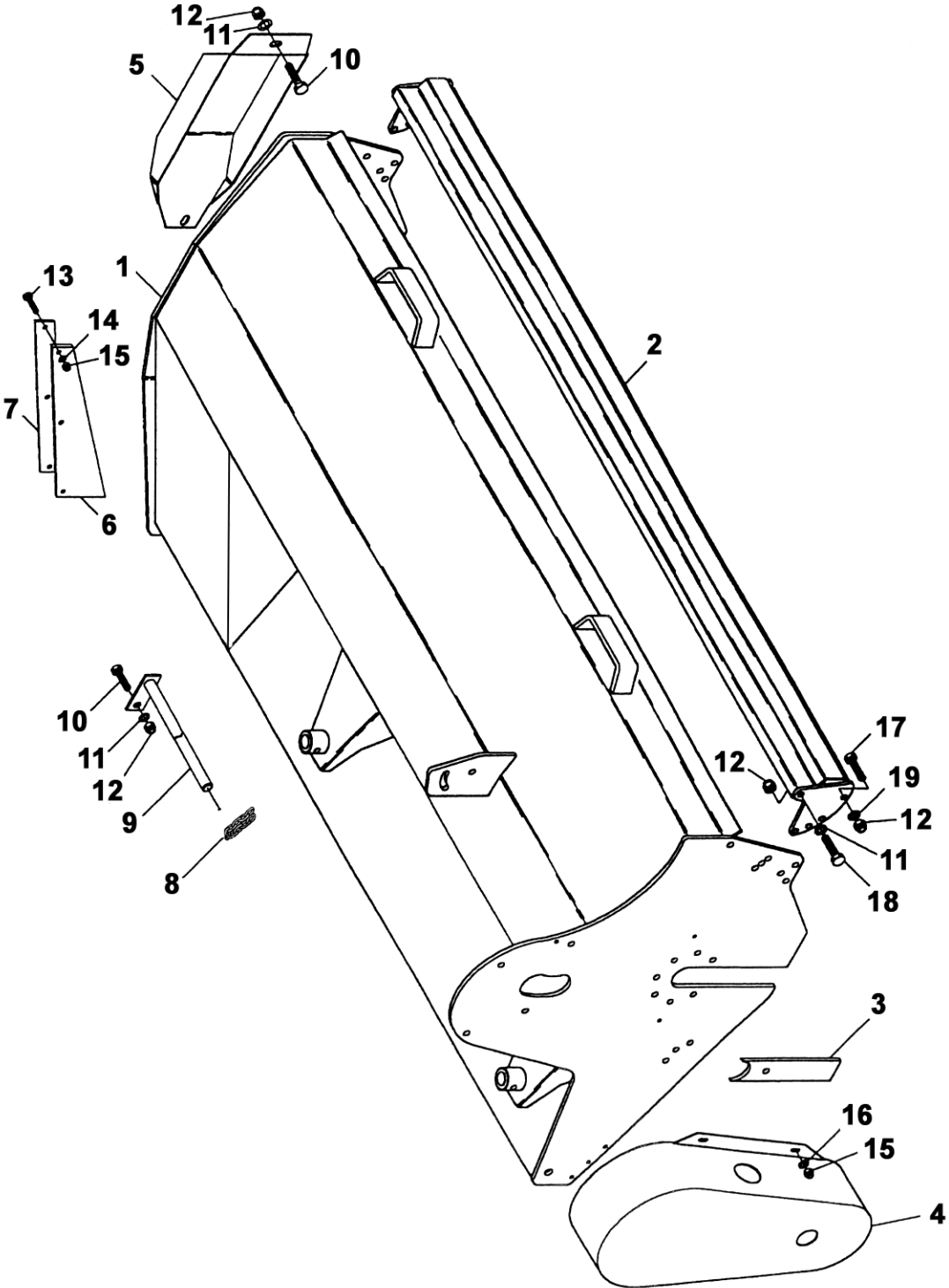

# GRF DECK ASSEMBLY

<u>REF#</u>	<u>QTY.</u>	<u>PART NO.</u>	<u>DESCRIPTION</u>
1	1	13001083	Deck Frame GRF69
1	1	13001084	Deck Frame GRF79
1	1	13001085	Deck Frame GRF89
1	1	13001086	Deck Frame GRF98
1	1	13001087	Deck Frame GRF108
2	1	13008019	Grass Hatch GRF69
2	1	13008020	Grass Hatch GRF79
2	1	13008021	Grass Hatch GRF89
2	1	13008022	Grass Hatch GRF98
2	1	13008023	Grass Hatch GRF108
3	1	13001011	Cover Plate
4	1	13010001	Belt Cover
5	1	13010003	Side Cover
6	1	13010033	Rubber Shield
7	1	13010034	Support Plate
8	See Pg. 17	14310004	Deflector Chain
9	1	13010012	Shaft, Deflector Chain
10	3	96612221	Bolt M14 x 30
11	5	97095511	Washer 15 x 28
12	7	97972321	Lock Nut M14
13	3	96605921	Bolt M8 x 40
14	3	97494831	Lock Washer
15	7	97971721	Lock Nut
16	4	97094911	Washer
17	2	96695723	Allen Bolt M14 x 40
18	2	96612421	Bolt M14 x 40
19	2	97495131	Lock Washer



# GRF A-FRAME ASSEMBLY

<u>REF#</u>	<u>QTY.</u>	<u>PART NO.</u>	<u>DESCRIPTION</u>
1	1	13004088	A-Frame
2	1	19704010	Support, P.T.O.
3	1	96689323	Bolt M6 x 25
4	2	96618421	Bolt M20 x 150
5	2	97096011	Washer
6	2	97972821	Lock Nut
7	1	14311003	Stand
8	1	14311001	Cap, Plastic
9	1	14311010	Pin w/Chain
10	1	97486611	Bolt M6.3 x 19
11	1	14311006	Support
12	1	19404015	Pin w/Chain
13	2	19704013	Lift Pin
14	2	96601821	Bolt M10 x 45
15	2	97971821	Lock Nut
16	8	96614921	Bolt M16 x 45
17	8	97972521	Lock Nut
18	4	13004091	Bracket, Support
19	2	13004031	Lift Pin Cat. 1 (Option, not shown)
20	2	13004143	Bushing Cat 1-2 (Option, not shown)

# OPTIONAL GRF RAKE HATCH ASSY

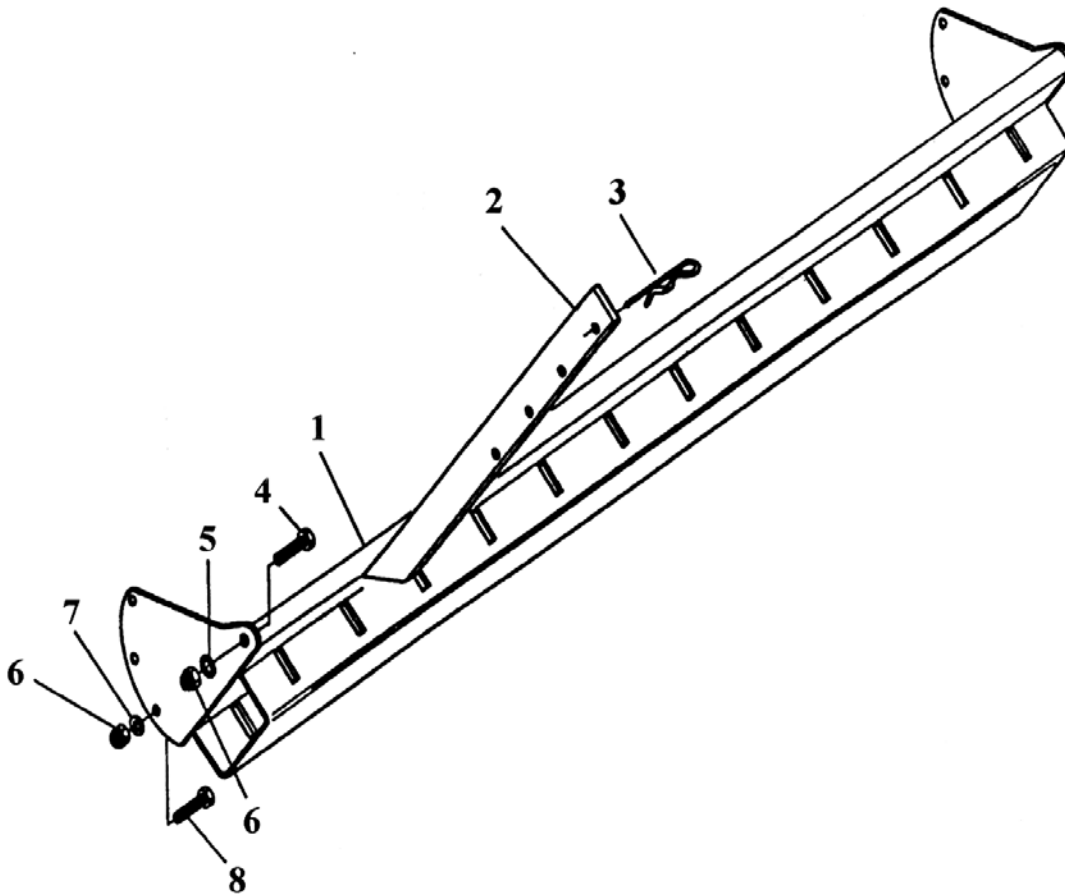

<u>REF#</u>	<u>QTY.</u>	<u>PART NO.</u>	<u>DESCRIPTION</u>
1	1	13008027	Rake Hatch GRF69
1	1	13008028	Rake Hatch GRF79
1	1	13008029	Rake Hatch GRF89
1	1	13008030	Rake Hatch GRF98
1	1	13008031	Rake Hatch GRF108
2	As Req'd	13008050	Rake 1/2 x 1 9/16 x 20
3	As Req'd	91009060	Hair Pin
4	2	96695723	Bolt M14 x 40
5	2	97095511	Washer 15 x 28
6	4	97972321	Lock Nut M14
7	2	97495131	Lock Washer
8	2	96612421	Bolt M14 x 40

# GRF ROTOR SHAFT ASSEMBLY

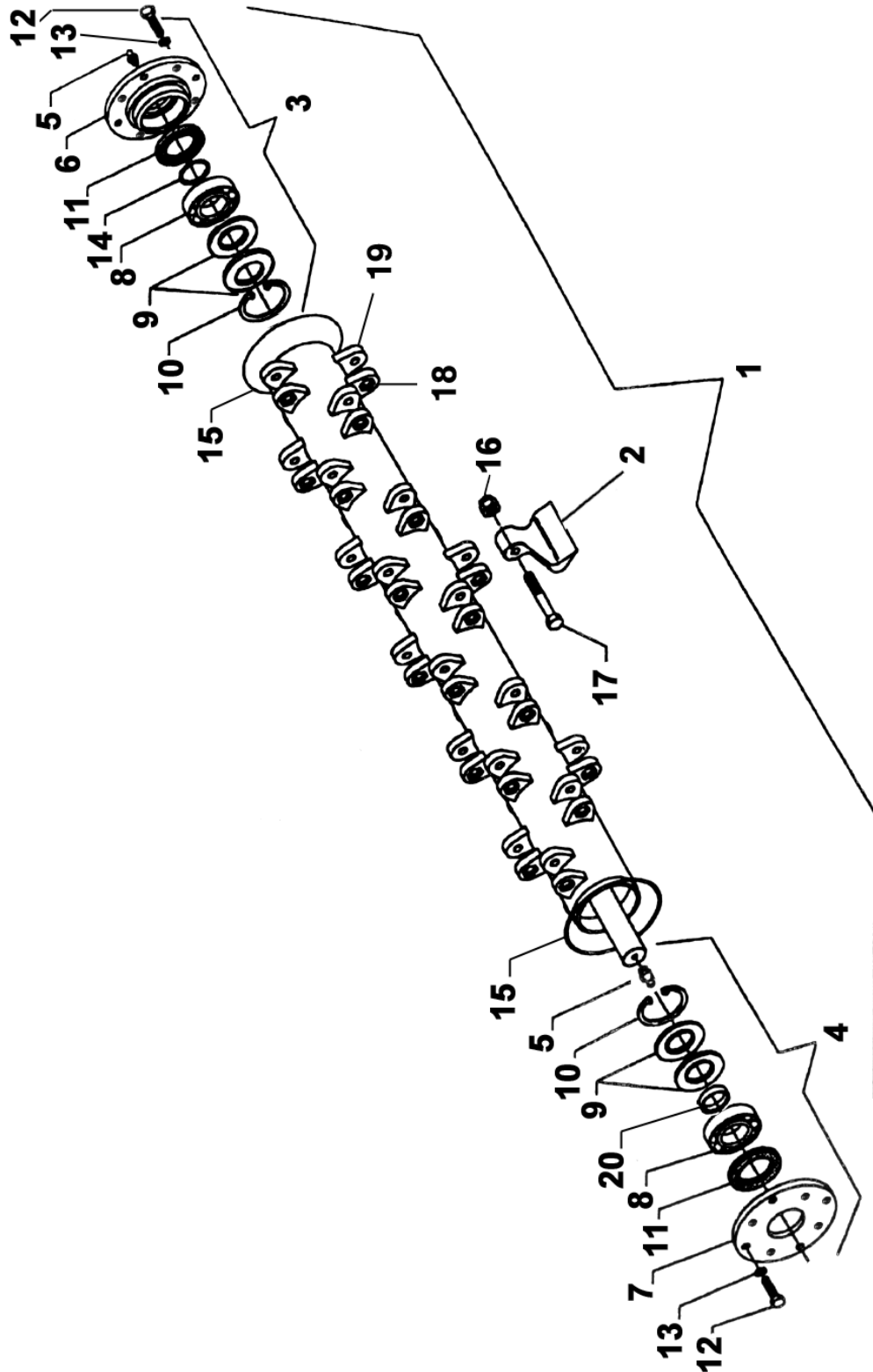

# GRF ROTOR SHAFT ASSEMBLY

<u>REF#</u>	<u>QTY.</u>	<u>PART NO.</u>	<u>DESCRIPTION</u>
1	1	13002028	Rotor Assembly GRF69
1	1	13002029	Rotor Assembly GRF79
1	1	13002059	Rotor Assembly GRF89
1	1	13002060	Rotor Assembly GRF98
1	1	13002061	Rotor Assembly GRF108
2	See Pg. 17	48020002	Flail Knife GRF69 & 79
2	See Pg. 17	48020001	Flail Knife GRF89, 98, & 108
3	1	13002034	R.H. Support Hub Assy. GRF69 & 79
3	1	13002065	R.H. Support Hub Assy. GRF89, 98, & 108
4	1	13002035	L.H. Support Hub Assy. GRF69 & 79
4	1	13002066	L.H. Support Hub Assy. GRF89, 98, & 108
5	2	97036711	Grease Zerk
6	1	13002013	R.H. Support Hub GRF69 & 79
6	1	13002012	R.H. Support Hub GRF89, 98, & 108
7	1	13002014	L.H. Support Hub GRF69 & 79
7	1	13002048	L.H. Support Hub GRF89, 98, & 108
8	2	22209	Bearing GRF69 & 79
8	2	22210	Bearing GRF89, 98, & 108
9	2	13002037	2-pc. Metal Seal GRF69 & 79
9	2	13002038	2-pc. Metal Seal GRF89, 98, & 108
10	2	96874976	Snap Ring 85 x3 GRF69 & 79
10	2	96875176	Snap Ring 90 x 3 GRF89, 98, & 108
11	2	45x80x10	Oil Seal GRF69 & 79
11	2	50x90x10	Oil Seal GRF89, 98, & 108
12	16	96612221	Bolt M14 x3 0
13	16	97495131	Lock Washer
14	1	96867676	Circlip 45 x 1.7 GRF69 & 79
14	1	96867876	Circlip 50 x 2 GRF89, 98, & 108
15	2	13002102	Protection Shield GRF69 & 79
15	2	13002103	Protection Shield GRF89, 98, & 108
16	See Pg. 17	13002076	Special Lock Nut
17	See Pg. 17	13002075	Special Bolt M16 x 1.2 x 90
18	See Pg. 17	15002039	Hex Flail Knife Ear
19	See Pg. 17	15002038	Flail Knife Ear
20	1	98045816	Spacer 45 x 55 x 2.5 GRF69 & 79
20	1	98045116	Spacer 50 x 62 x 2.5 GRF89, 98, & 108

# QUANTITY MATCHING CHART

PART NO.	DESCRIPTION	MODELS				
		GRF69	GRF79	GRF89	GRF98	GRF108
14310004	Deflector Chain	61	65	69	73	77
48020002	Flail Knife Assy.	18	21			
48020001	Flail Knife Assy.			21	24	27
13002075	Bolt, Knife	18	21	21	24	27
13002076	Lock Nut, Knife	18	21	21	24	27
150002039	Hex Knife Ear	18	21	21	24	27
15002038	Knife Ear	18	21	21	24	27

# GRF ROLLER ASSEMBLY

Prior to S/N 701300027

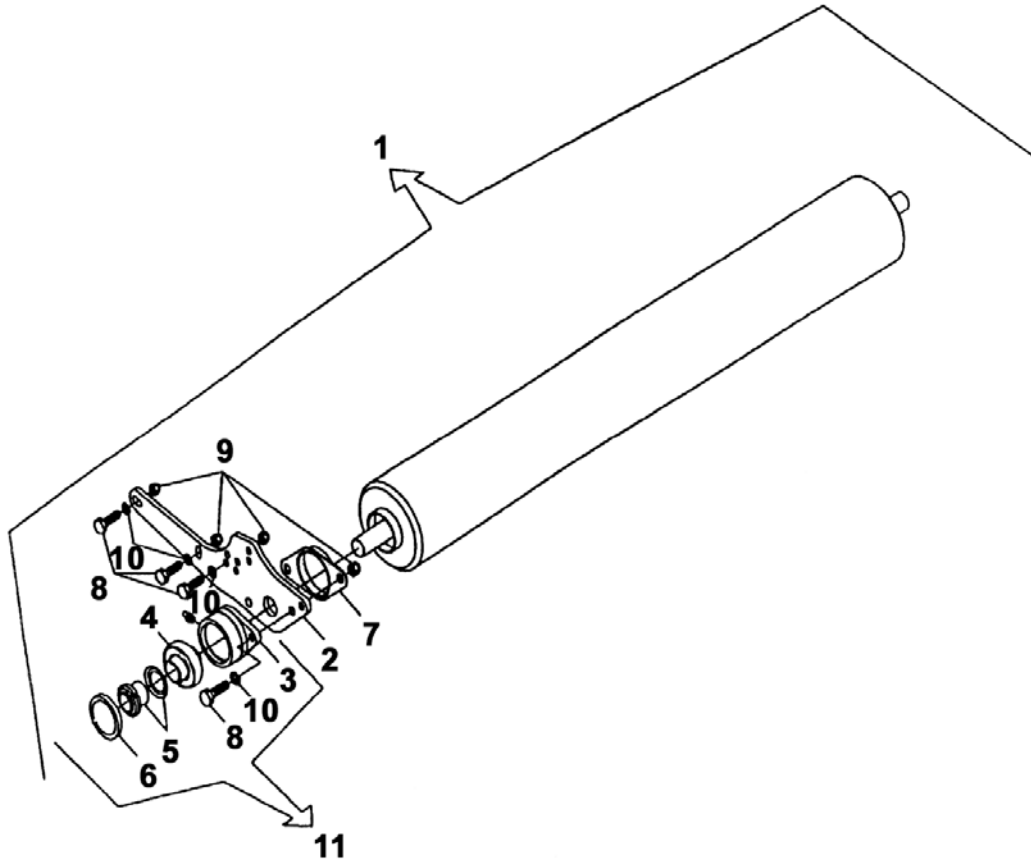

<u>REF#</u>	<u>QTY.</u>	<u>PART NO.</u>	<u>DESCRIPTION</u>
1	1	13005118	Complete Roller Assy. GRF69
1	1	13005119	Complete Roller Assy. GRF79
1	1	13005075	Complete Roller Assy. GRF89
1	1	13005076	Complete Roller Assy. GRF98
1	1	13005077	Complete Roller Assy. GRF108
2	2	13005071	Roller Support
3	2	14305028	Bearing Hub Support
4	2	UK209	Bearing
5	2	14305043	Nut H309
6	2	14310013	Bearing Cover
7	2	14305024	Flange
8	8	96602921	Bolt M18 x 55
9	8	97972921	Lock Nut M18
10	8	97095911	Washer
11	2	14305040	Roller Support Complete

# GRF ROLLER ASSEMBLY

After S/N 701300027

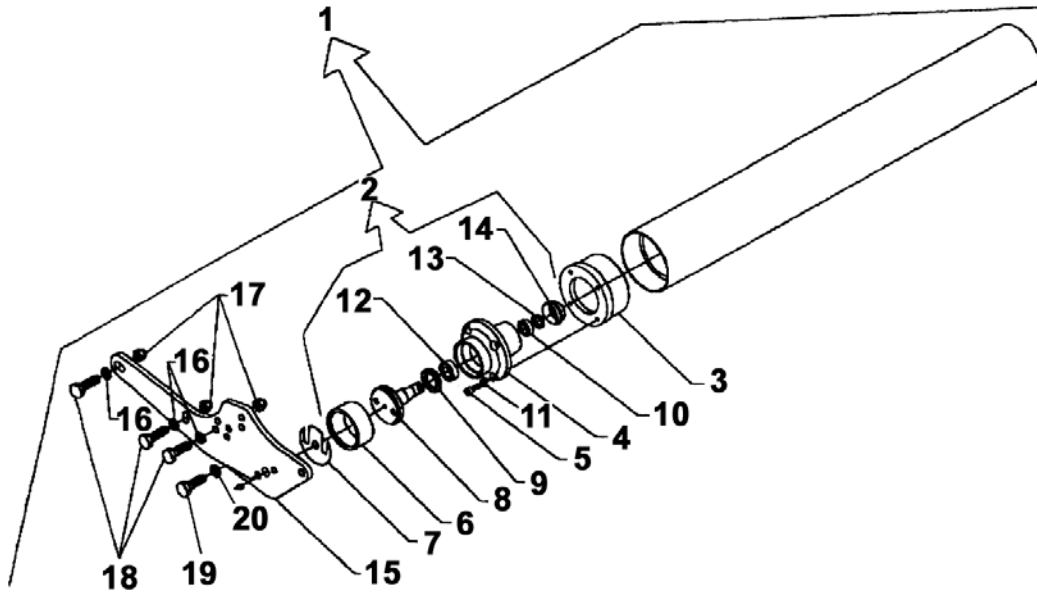

<u>REF#</u>	<u>QTY.</u>	<u>PART NO.</u>	<u>DESCRIPTION</u>
1	1	13005204	Complete Roller Assy. GRF69
1	1	13005205	Complete Roller Assy. GRF79
1	1	13005206	Complete Roller Assy. GRF89
1	1	13005207	Complete Roller Assy. GRF98
1	1	13005208	Complete Roller Assy. GRF108
2	2	13005000	Hub Assembly
3	2	13005163	Bearing Hub Support Weld-on GRF69 & 79
3	2	13005164	Bearing Hub Support Weld-on GRF89 - 108
4	2	13005160	Hub
5	8	96692223	Bolt M10 x 30
6	2	13005165	Spacer
7	As Req'd	11005069	Shim 0.5mm
7	As Req'd	11005068	Shim 1.0mm
8	2	13005143	Axle
9	2	58x72x8	Oil Seal
10	2	30205	Bearing
11	8	97494934	Washer D.10
12	2	32207	Bearing
13	2	13005088	Nut M25 x 1.5
14	2	13005162	Dust Cap
15	2	13005001	Roller Support
16	8	97495031	Washer
17	8	97972321	Lock Nut M14
18	8	96612421	Bolt M14 x 40
19	4	96612221	Bolt M14 x 30
20	4	97495131	Washer M15

# TAILWHEEL ASSEMBLY

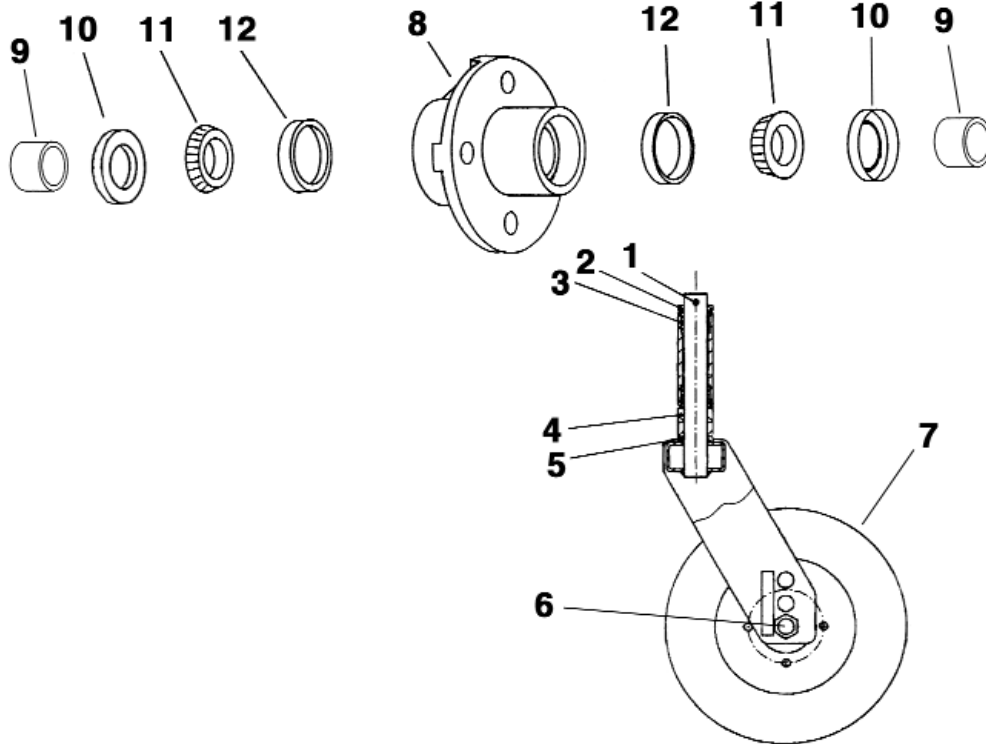

<u>REF#</u>	<u>PART NO.</u>	<u>DESCRIPTION</u>
1	14311010	Lynch Pin
2	13006076	Spacer 10mm
3	11204010	Bushing
4	13006077	Spacer 25mm
5	13006078	Washer
6	501280	Axle Bolt Assembly
7	0311	Laminated Tire
8	0312	Hub Assembly (includes 8 - 12)
9	HB125075	Bushing Seal
10	12411	Grease Seal
11	L44643	Bearing Cone
12	L44610	Bearing Cup

# GRF DRIVE ASSEMBLY

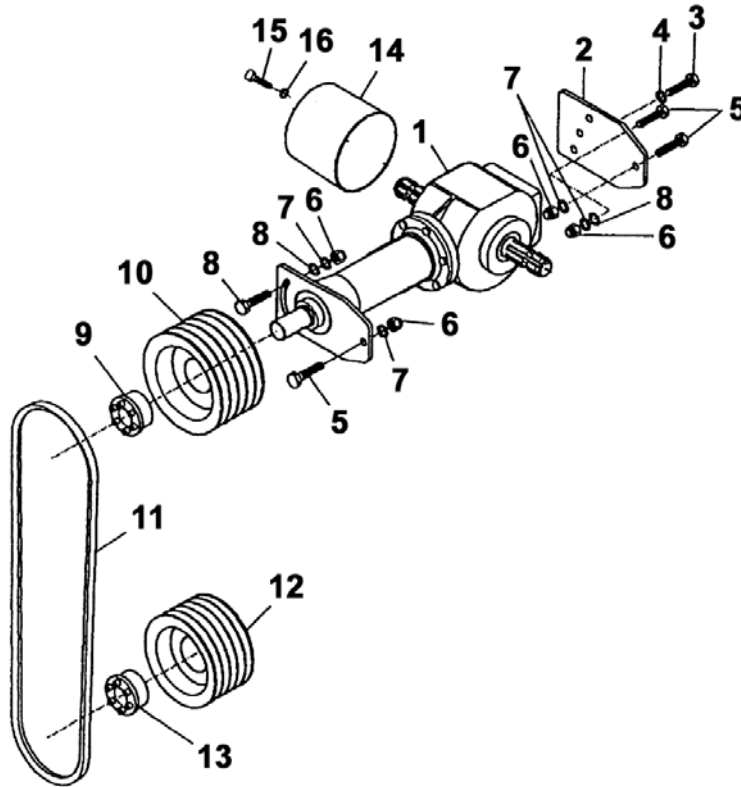

<u>REF#</u>	<u>QTY.</u>	<u>PART NO.</u>	<u>DESCRIPTION</u>
1			Advise Model & Serial Number
2	1	13003003	Support Plate
3	4	96609921	Bolt M12 x 30
4	1	97495031	Lock Washer
5	4	97051921	Bolt M14 x 1.5 x 40
6	4	97973221	Nut M14 x 1.5
7	4	97495131	Lock Washer
8	1	97095511	Washer 15 x 28
9	1	13003005	Taper Lock 35 x 80
10	1	13003013	Pulley 4SPB225 GRF69 & 79
10	1	13003015	Pulley 5SPB250 GRF89, 98, & 108
11	4	13003077	Belt SPBX1285 GRF69 & 79
11	5	48030057	Belt SPBX1340 GRF89, 98, & 108
12	1	13003012	Pulley 4SPB160 GRF69 & 79
12	1	13003017	Pulley 5SPB180 GRF89, 98, & 108
13	1	13003006	Taper Lock 45 x 80
14	2	13010026	PTO Safety Cone
15	8	96605321	Bolt M8 x 12
16	8	97094911	Washer

# GRF GEARBOX ASSEMBLY

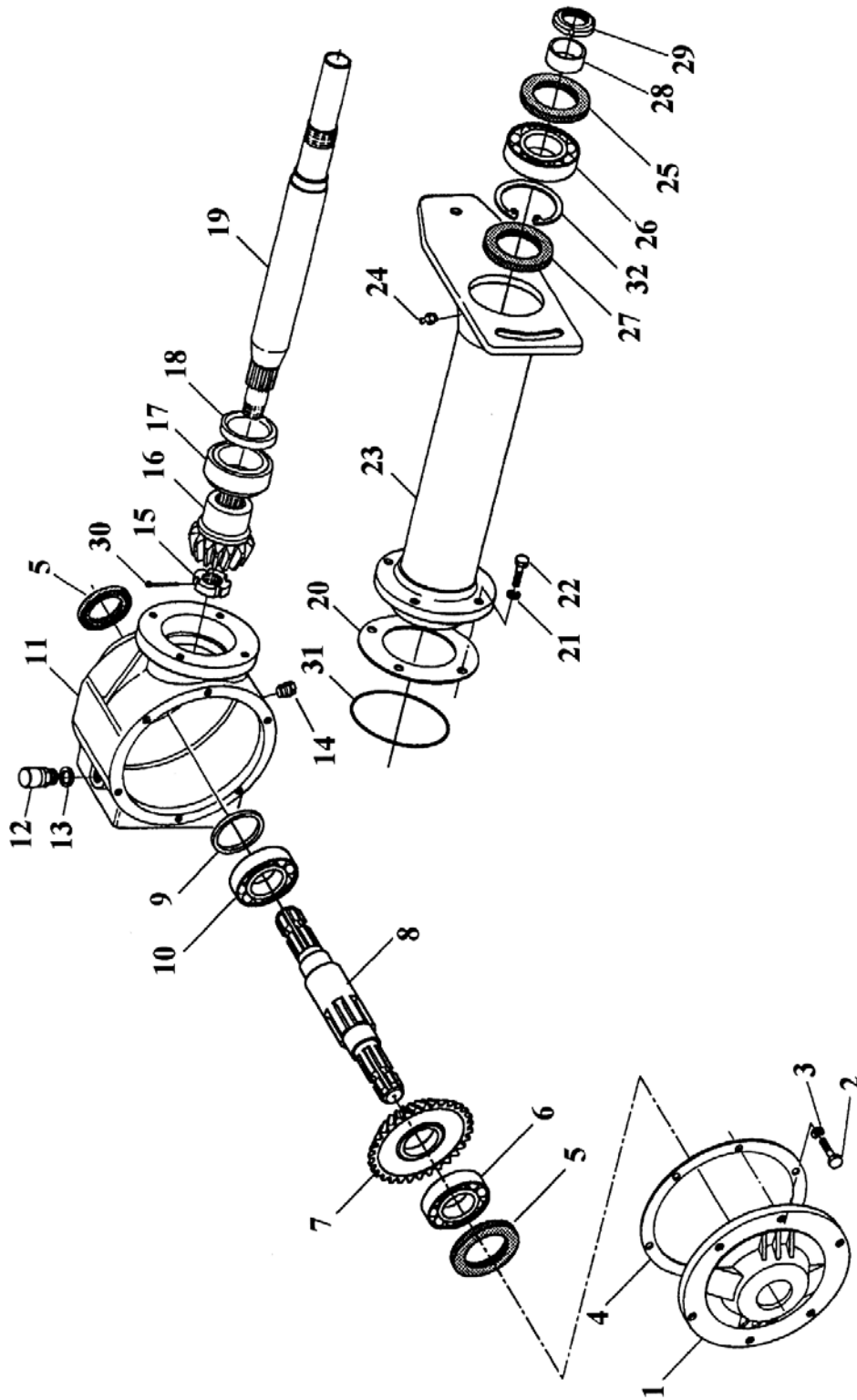

# GRF GEARBOX ASSEMBLY

<u>REF#</u>	<u>QTY.</u>	<u>PART NO.</u>	<u>DESCRIPTION</u>
1	1	48030192	Front Cover
2	6	96605627	Bolt M8 x 25
3	6	97494834	Lock Washer
4	1	48030037	Gasket
5	2	40x72x10	Oil Seal
6	1	32011	Bearing
7	1	48030031	Bevel Gear Z=30 540 RPM
7	1	48030027	Bevel Gear Z=21 1000 RPM
8	1	48030206	Input Shaft
9	As Req'd	98045016	Shim 0.2mm
9	As Req'd	98045216	Shim 0.3mm
9	As Req'd	98046016	Shim 0.5mm
9	As Req'd	98045516	Shim 2.6mm
10	1	6208	Bearing
11	1	48030288	Gearbox Housing
12	1	48030056	Fill Plug
13	1	48030273	Washer Gasket
14	1	48030272	Drain Plug
15	1	48030238	Nut M24 x 1.5
16	1	48030032	Pinion Z-12 540 RPM
16	1	48030026	Pinion Z-15 1000 RPM
17	1	32010	Bearing
18	1	50x72x10	Oil Seal
19	1	<i>Call Gearmore</i>	Extension Shaft
20	1	48030553	Gasket
21	4	97495034	Lock Washer
22	4	96609921	Bolt M12 x 30
23	1	<i>Call Gearmore</i>	Extension Tube
24	1	97036911	Grease Zerk M10
25	1	50x80x10	Oil Seal
26	1	30208	Bearing
27	1	48030632	Metal Seal
28	1	48030631	Spacer
29	1	19703042	Ring Nut M40 x 1.5
30	1	48030213	Cotter Key
31	1	97284380	O-Ring 3225
32	1	96874776	Circlip M80 x 2.5

# GRF69-89 PTO SHAFT

Bondioli & Pavesi

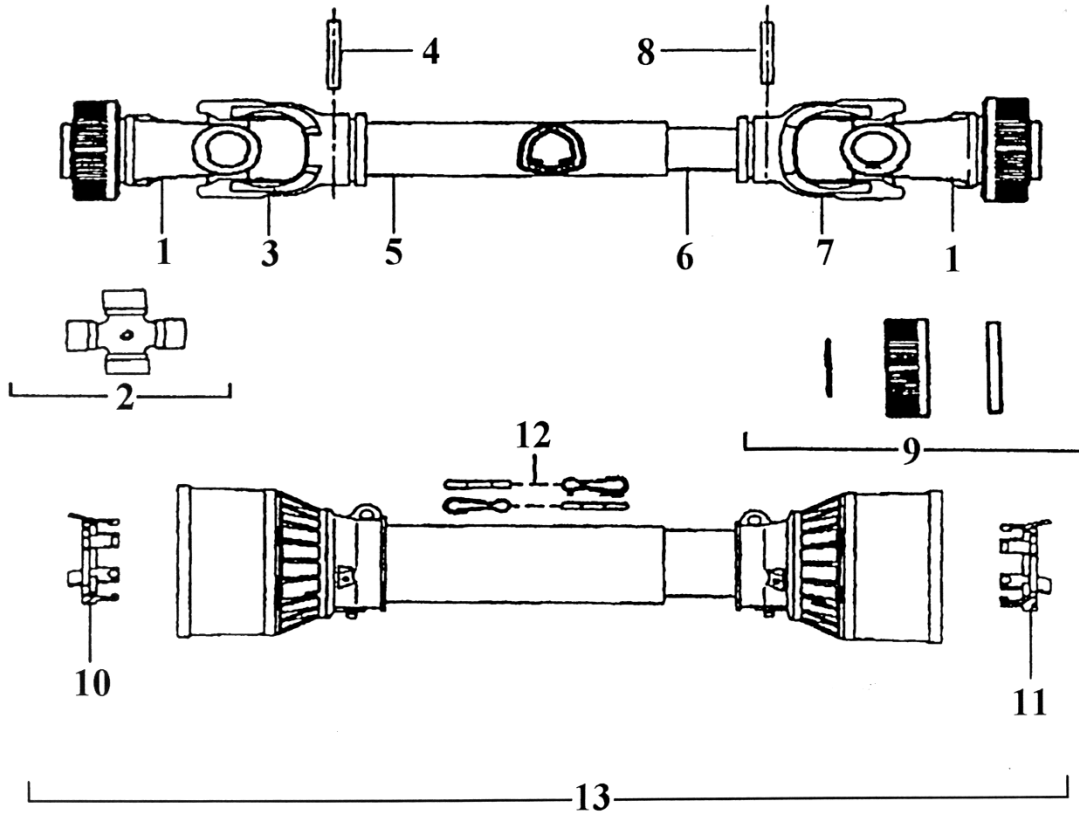

<u>REF#</u>	<u>QTY.</u>	<u>PART NO.</u>	<u>DESCRIPTION</u>
1	2	572060351	RS Yoke 1-3/8 6 Spline
2	2	41206	#6 Cross Kit
3	1	204066851	Outer Tube Yoke
4	1	341042000	Roll Pin O.T.
5	1	225690860	Outer Drive Tube 860 mm
6	1	225110860	Inner Drive Tube 860 mm
7	1	204066852	Inner Tube Yoke
8	1	341043000	Roll Pin I.T.
9	2	240003051	RS Collar Kit
10	1	255060005	Shield Bearing Outer
11	1	255060006	Shield Bearing Inner
12	2	252000001	Safety Chain
13	1	5F06086FF	Complete Shield w/Bearings
	1	7106086T07S07	Complete Driveline Assembly

*Please specify driveline manufacturer when ordering parts.*

# GRF69-89 PTO SHAFT

## Weasler

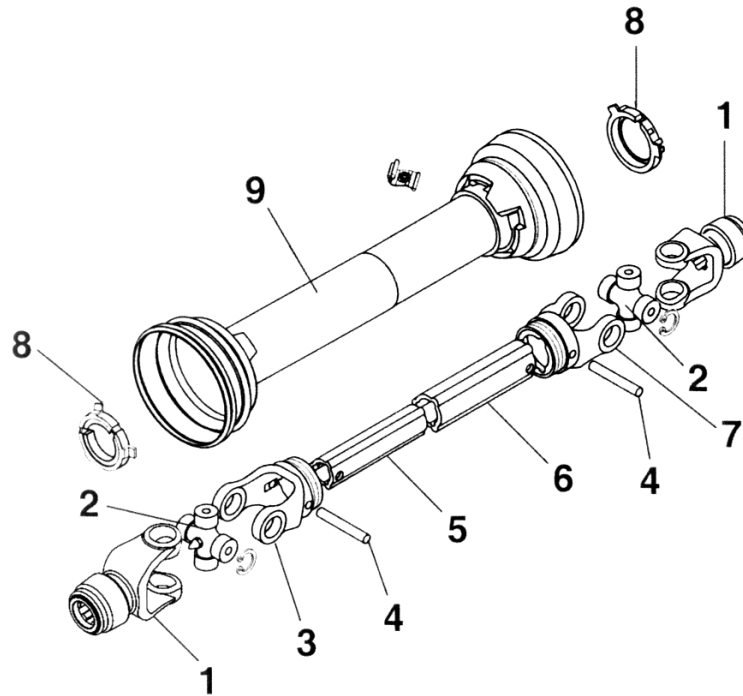

<u>REF#</u>	<u>QTY.</u>	<u>PART NO.</u>	<u>DESCRIPTION</u>
1	2	110-8606	Yoke Auto Lock
2	2	201-8692	Cross and Bearing Kit
3	1	410.600245	Yoke Inner Tube
4	2	795.1080	Spring Pin 10 x 80
5	1	710.454	Inner Tube
6	1	710.544	Outer Tube
7	1	410.600254	Yoke Outer Tube
8	2	961-3567	Bearing Kit
9	1	902-3560	Shield Kit
	1	13006500	Safety Chain Kit (Not Shown)
	1	AB608363	Complete Driveline Assembly

*Please specify driveline manufacturer when ordering parts.*

# GRF98-108 PTO SHAFT

Bondioli & Pavesi

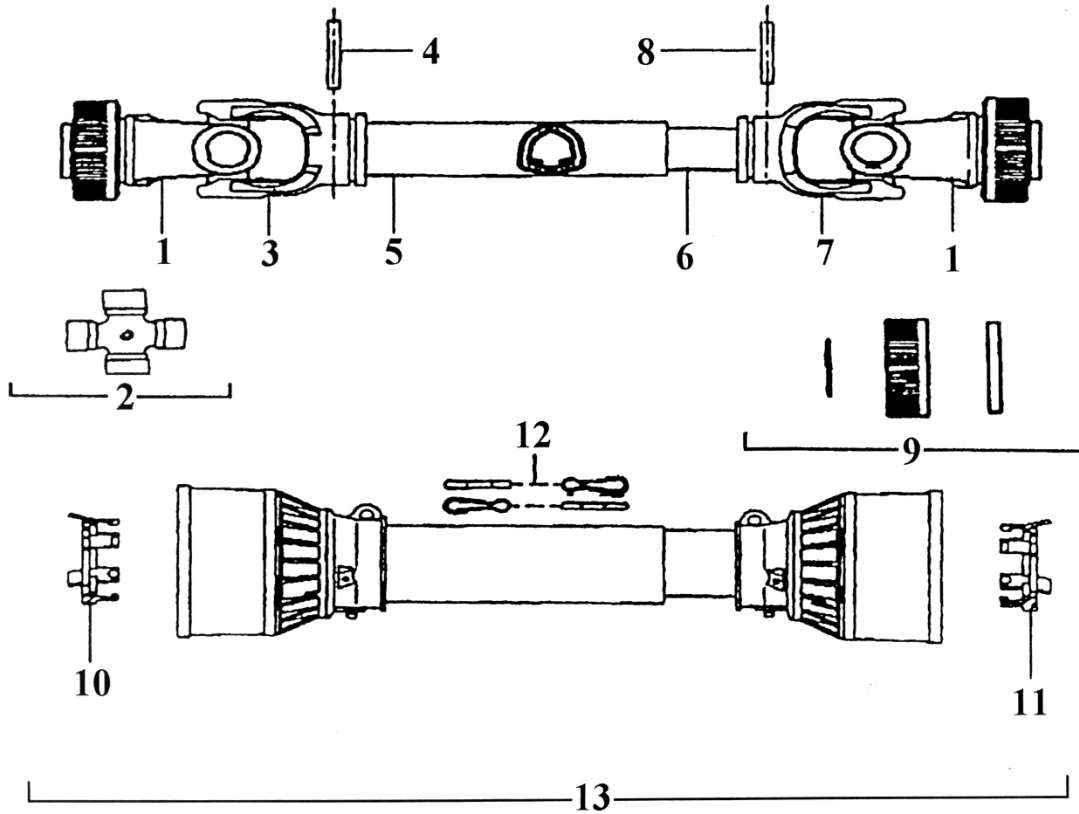

<u>REF#</u>	<u>QTY.</u>	<u>PART NO.</u>	<u>DESCRIPTION</u>
1	2	572080351	RS Yoke 1-3/8 6 Spline
1	1	572083751	RS Yoke 1-3/8 21 Spline (Optional)
2	2	41208	#8 Cross Kit
3	1	204086860	Outer Tube Yoke
4	1	341054000	Roll Pin O.T.
5	1	225730860	Outer Drive Tube
6	1	225690860	Inner Drive Tube
7	1	204086861	Inner Tube Yoke
8	1	341055000	Roll Pin I.T.
9	2	240003551	RS Collar Kit
10	1	255080005	Shield Bearing Outer
11	1	255080006	Shield Bearing Inner
12	2	252000005	Safety Chain
13	1	5F08086F6	Complete Shield w/Bearings
	1	7108086T07S07	Complete Driveline Assembly

# GRF98-108 PTO SHAFT

## Weasler

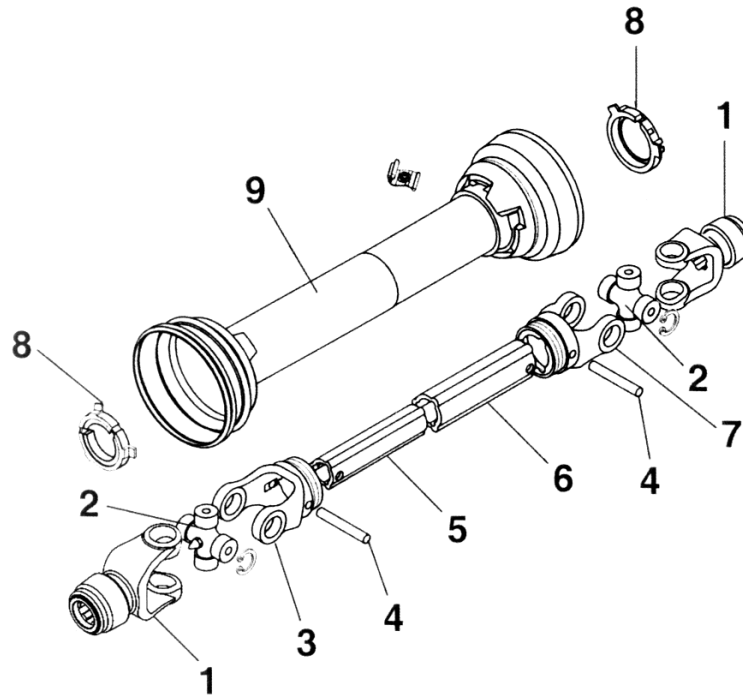

<u>REF#</u>	<u>QTY.</u>	<u>PART NO.</u>	<u>DESCRIPTION</u>
1	2	110-8606	Yoke Auto Lock
1	-	400.724621	Yoke Auto Lock
2	2	201-6806	Cross and Bearing Kit
3	1	410.800245	Yoke Inner Tube
4	2	795.1290	Spring Pin 12 x 90
5	1	710.554	Inner Tube
6	1	710.634	Outer Tube
7	1	410.800263	Yoke Outer Tube
8	2	961-4589	Bearing Kit
9	1	902-4560	Shield Kit
	1	13006500	Safety Chain Kit (Not Shown)
	1	ZB8086638	Complete Driveline Assembly 1-3/8" 6 Spline
	1	ZB80863821	Complete Driveline Assembly 1-3/8" 21 Spline

*Please specify driveline manufacturer when ordering parts.*

# LIMITED WARRANTY



GEARMORE, INC., warrants each new Gearmore product to be free from defects in material and workmanship for a period of twelve (12) months from date of purchase to the original purchaser. This warranty shall not apply to implements or parts that have been subject to misuse, negligence, accident, or that have been altered in any way.

Our obligation shall be limited to repairing or replacement of any part, provided that such part is returned within thirty (30) days from date of failure to Gearmore through the dealer from whom the purchase was made, transportation charges prepaid.

This warranty shall not be interpreted to render us liable for injury or damages of any kind or nature, direct, consequential or contingent, to person or property. This warranty does not extend to loss of crops, loss because of delay in harvesting or any other expenses, for any other reasons.

Gearmore in no way warrants engines, tires, or other trade accessories, since these items are warranted separately by these respective manufacturers.

Gearmore reserves the right to make improvements in design or changes in specification at any time, without incurring any obligations to owners or units previously sold.

GEARMORE, INC.  
13477 Benson Ave.  
Chino, CA 91710

Always refer to and heed machine operating warning decals on machine.

*The serial number of this product is stored in our computer database, thus submitting a warranty registration card is not required.*