

Explore more of our products by clicking or scanning here!→

PROFILMATIC VINE TRIMMERS

P2200S SERIES FOR DIFFERENT TRELLIS SYSTEM



**EXPERIENCE
UNRIVALED
ADAPTABILITY,
RELIABILITY,
AND EFFICIENCY
IN THE FIELD.**

The new P2200S Universal Vine Trimmer was developed to be adjustable for a number of different trellis systems. This Vine Trimmer can be set for Vertical Shoot Positioned (VSP), Gabe Trellis, California Sprawl and Double Cross arm Trellis Systems. The head of the COLLARD Trimmers is the unique lightweight aluminum alloy extrusion that provides a rugged, rustproof framework for the cutting blades. This blade framework is so strong that it has a lifetime guarantee. The exclusive saber shaped, non-clogging stainless steel blades never need sharpening. Our trimmers eliminate excess vine growth, open canopies for better air circulation and greatly improve spray and dust penetration. Collard designed the first vine trimmers and continues to be the world leader in vine trimmers.

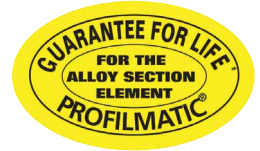

DESIGNED FOR TRIMMING

The aerodynamic shape of this profiled body was designed to facilitate more efficient penetration of the Trimmer **PROFILMATIC®** into the canopy, this profile also improves the fluid discharge of cut material.

RIGID BLADE ELEMENT (**COLLARD®** patent)

This extreme duty assembly is nearly indestructible due to the unique design. This unit is without equal and guarantees the reliability of the blade transmission.

PROTECTED TRANSMISSION

Enclosed by a special cover, the transmission is completely protected against debris, dust, rain, etc.

POWERFUL TRANSMISSION

The **PROFILMATIC®** is even more powerful, ensuring a very high working speed yet reducing the required power input.

SHOCK ABSORPTION

The leading edge of this section is made of synthetic material, it absorbs possible shocks, recessed screws of connection between the modules, ensures a smoother profile which facilitates the smooth evacuation of cut material.

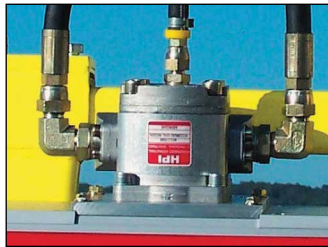
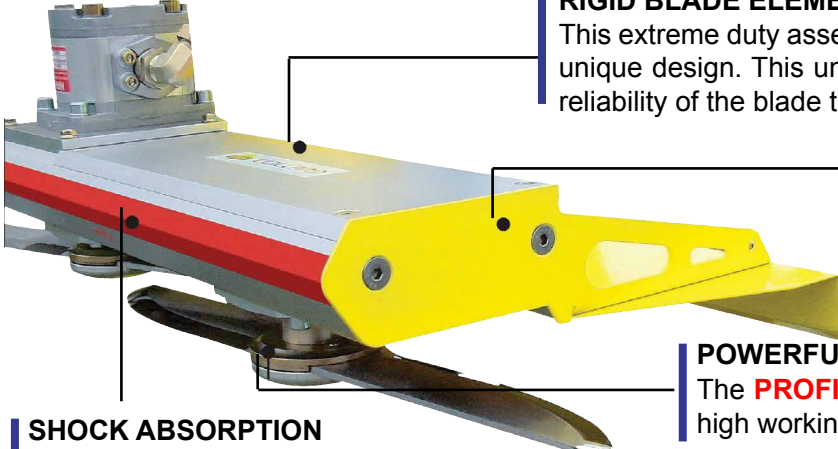

HYDRAULIC POWER

Only modern hydraulic drive technology can provide high power transmission for trimming with exceptional reliability and durability.



EXCEPTIONAL HYDRAULIC COMPONENTS

Trimmer motors, distributor, etc. are all fitted with 60 micron oil filters for maximum protection. Special flow divider regulate the maximum speed of the blades. All settings are sealed at the factory for reliability.



SAFETY GUARDS

The **PROFILMATIC®** has a one piece rigid deflector, providing additional strength, offering complete protection and conformity of the applicable safety norms.



BLADE SAFETY COVERS (**COLLARD®** patent)

Designed to remove the contact of the moving parts with the vegetation, it safeguards the quality of cut. Providing extra security to blade attachment, an added safety feature.

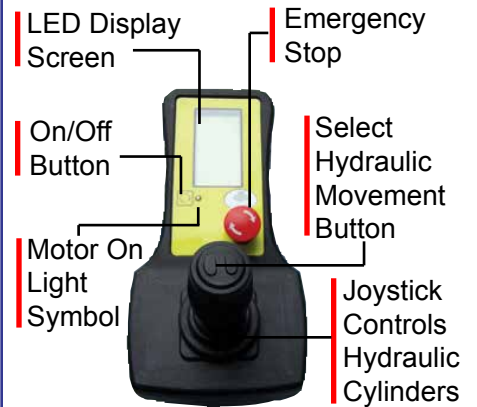

JOYSTICK

Compact joystick with "user friendly" controls.



TOP ADJUSTMENT (Optional)

The height adjustment of the top cutting element is independent to the vertical cutting element.



CAN BE ADJUSTED TO MANY POSITIONS

VERTICAL SHOOT POSITIONED (VSP)

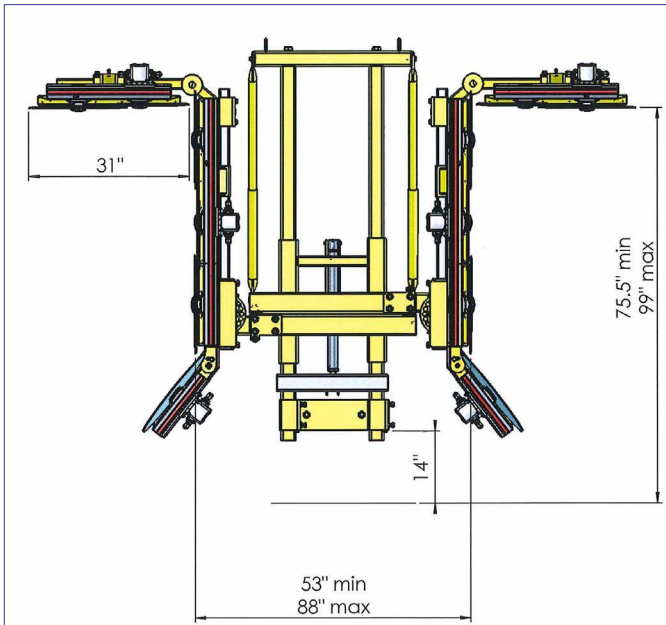

CALIFORNIA SPRAWL

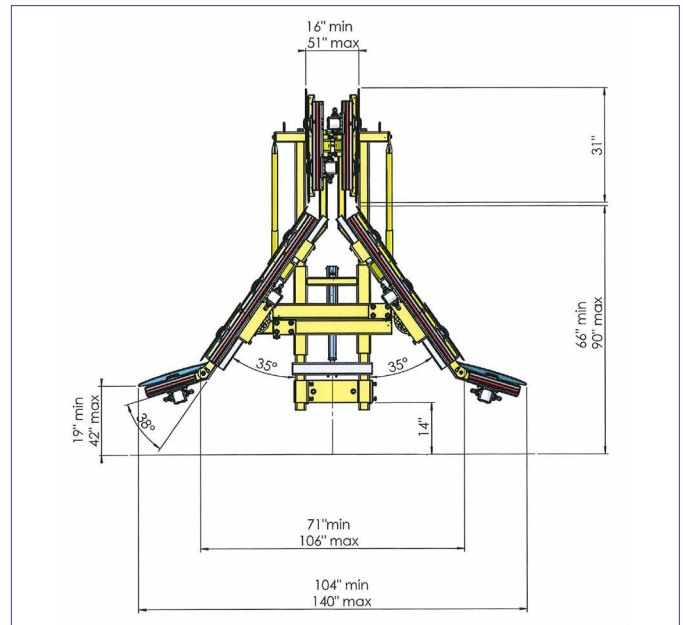

DOUBLE CROSSARM TRELLIS SYSTEM

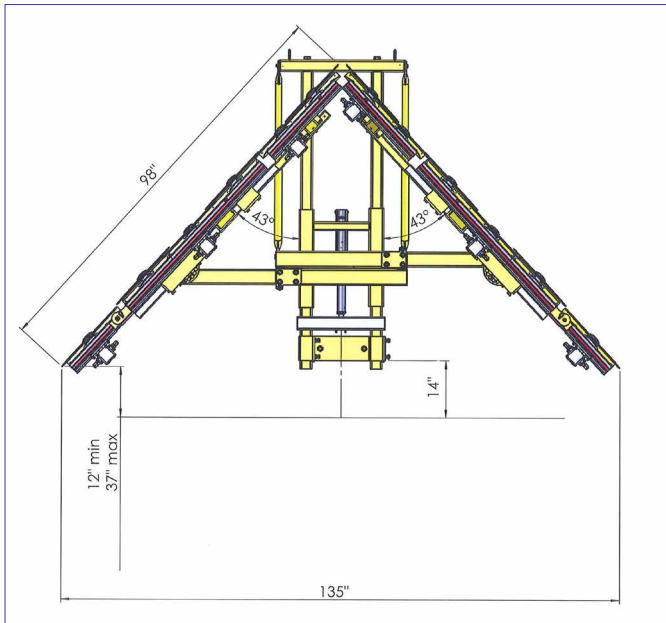

QUAD TRELLIS SYSTEM

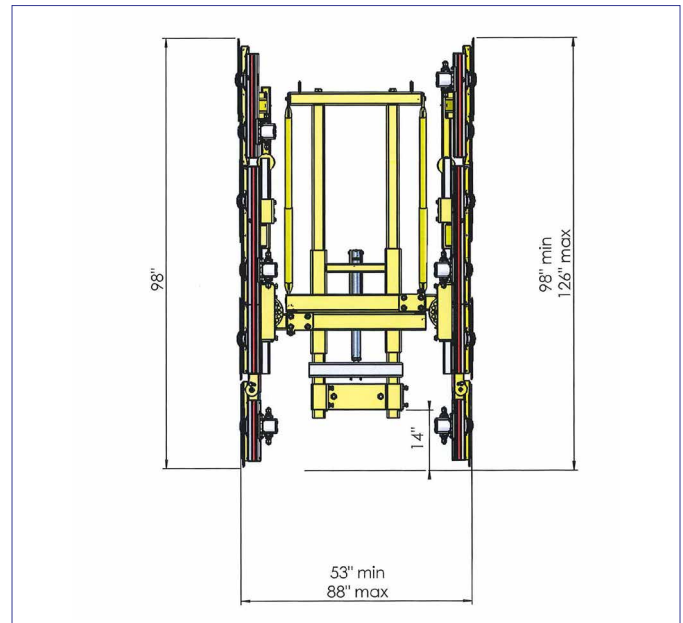



VINE TRIMMERS

HISTORY

The COLLARD family has been servicing wine growers for 5 generations. Andre Collard invented the first mechanical vine trimmer in 1962.

FEATURES

- Heavy duty reinforced, modular frame construction
- Total adjustments to fit many different trellis systems
- Adjustable hydraulic motor driven skirts can be set at 45° angle or vertical
- Designed to trim two half rows
- Flow limiter for motor controls
- "State of the Art" hydraulic motors to insure long life
- Smooth, thin line blade transmission for easy movement through the foliage
- Rigid deflectors so cut material is thrown away from the operator
- Unique hose track "E" system for hose protection

QUALITY CONTROL

Every stage in the production process is controlled to guarantee superior quality. After final assembly, each machine is run through the test bench where everything is checked - rotation speed, operating pressure, hydraulic cylinders, flow rates, etc. All this is done to insure that every machine leaving the factory is in perfect working order.

- Most operators are confidently operating the trimmer at 6 miles per hour
- Strong, but lightweight and easy to operate
- Blades turn at 2200 R.P.M., ensures clean cane ends, which dry and seal neatly to reduce the risk of disease
- Machine runs smooth and quiet, with no vibration
- Equipped with electro-hydraulic joystick controls for precise trimmer adjustments
- High speed stainless steel blades, self cleaning and never need sharpening
- Plastic guards to divert trash on top and side elements
- Hydraulic cylinders are fitted with load/hold check valves for safety in case a hose fails
- Trimmers come with all hoses, fittings and JIC couplers

SPECIFICATIONS

Order Code	Model #	Vertical Cut	No. of Blades	No. of Hyd. Motors	Row Width Adjustment	Weight
0113 4400	P2200S/Universal	63" to 98"	12	6	53" to 88"	1,200 lbs.
* Includes storage stand						

