



ROTARY MOWER

**Operation, Service
& Parts Manual For
L-48-40-XB-Z**

August 2001

TABLE OF CONTENTS

Introduction	1
Set-up Instructions	2
Tailwheel Height Adjustment	3
Preparation	4
Operational Safety	5-6
Maintenance Safety	7
Mower Safety Decals	8
General Maintenance	9
Troubleshooting	10
Mower Assembly	11-12
Gearbox Assembly	13-14
Driveline	15
Limited Warranty	16

Date of Purchase: _____

Model Number: _____

Serial Number _____

INTRODUCTION

We welcome you as an owner of a Gearmore mower. Please read the following instructions and refer to them when required:

BEFORE OPERATING YOUR MOWER

1. Inspect for damage and loose or missing parts. Make sure all fittings and drive components are secure.
2. Lubrication (*See Lubrication Section*).
3. Remove all large, foreign objects from area being mowed.

TO OPERATE MOWER

1. Connect mower to the tractor 3-point hitch lower link arms. (Make sure tractor and mower are on a level surface.)
2. Connect top link of tractor to mower and adjust turnbuckle so the mower is level with the ground.
3. Install driveshaft after making sure it is the correct length. (See separate warning sheet on the correct method of achieving the proper driveshaft length.)
4. Set height of tailwheel based on what height you want to cut. Example: The blades are set 1" above the skids. Thus, if you want a 2" cut, you would set tailwheel so skids are 1" above ground. (See Adj. Pg. 3)

NOTE: The mower is designed to float on the tailwheel and mower 3-point hitch, so the mower should not be dragged on the ground.

5. Set height stops on the tractor 3-point lift so mower will not be raised higher than necessary. Failure to do this could cause damage by putting excessive angle on the driveshaft.
6. Engage the tractor PTO when tractor engine is at idle speed. Engaging the PTO with engine at full speed will reduce the life of the driveshaft. For most cutting operations, a ground speed of 3 to 5 MPH and PTO at full 540 RPM is recommended.

SET-UP INSTRUCTIONS

1. With rotary Mower lying flat on the ground, remove the wire holding lift pins and PTO shaft from mower. Remove bolts from the free end of the lift arm braces. Remove bolts attaching lift arms and lift arm braces to the mower. Remove bolt holding swivel link assembly from lift arm brace.
2. Using the $\frac{5}{8}$ " x 3- $\frac{1}{2}$ " bolt and the lift arm spacer, attach a lift arm to the front hole of the right side deck tube as seen in Fig. A. Tighten only finger tight at this time.
NOTE: The lift arm should be on the gearbox side of the deck tube and the lift arm spacer should be inside the deck tube. Allow the lift arm to rotate until it rests against the gearbox plate.
3. Using the $\frac{5}{8}$ " x 3- $\frac{1}{2}$ " bolt, attach the right lift arm brace to the rear hold of the right side deck tube. Tighten only finger tight at this time. **NOTE: The lift arm brace should also be on the gearbox side of the deck tube.** Allow the lift arm brace to rotate until it rests against the previously installed lift arm.
4. Repeat steps 2 and 3 for the left side.
5. Insert the swivel spacer into the large hole in the swivel link.
6. Lift the right lift arm brace and hold while rotating the right lift arm forward. Align the holes in the free ends of the linkages. **NOTE: The lift arm brace should be on the outside of the lift arm. Insert the $\frac{5}{8}$ " x 6 $\frac{1}{2}$ " bolt.** Slide the swivel link assembly onto the free end of the bolt. The bolt should travel through the swivel link spacer. Rotate the left lift arm up and inset the bolt through the hole in it. Lift the left lift arm brace and slide it onto the bolt. Place a lock washer on the bolt and screw on nut. Tighten only finger tight. See Fig. B.
7. Insert the lift pins in each lift arm and tighten.

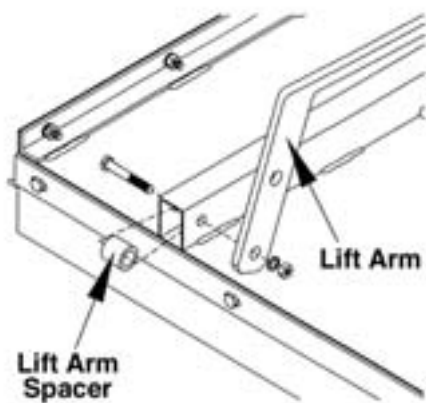

FIGURE A

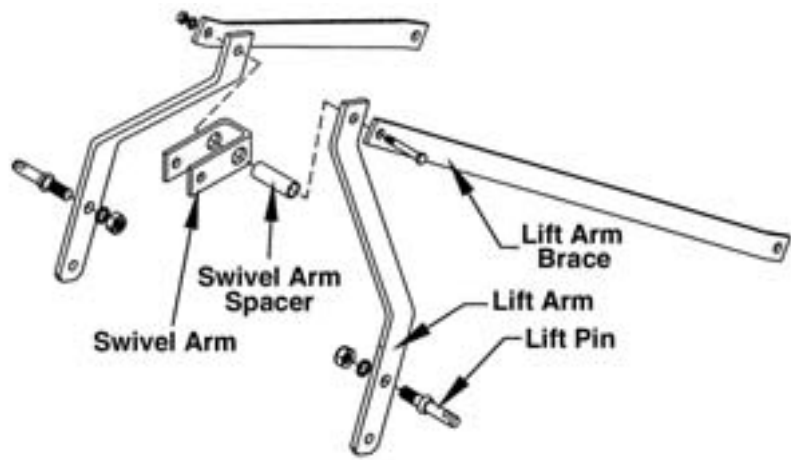
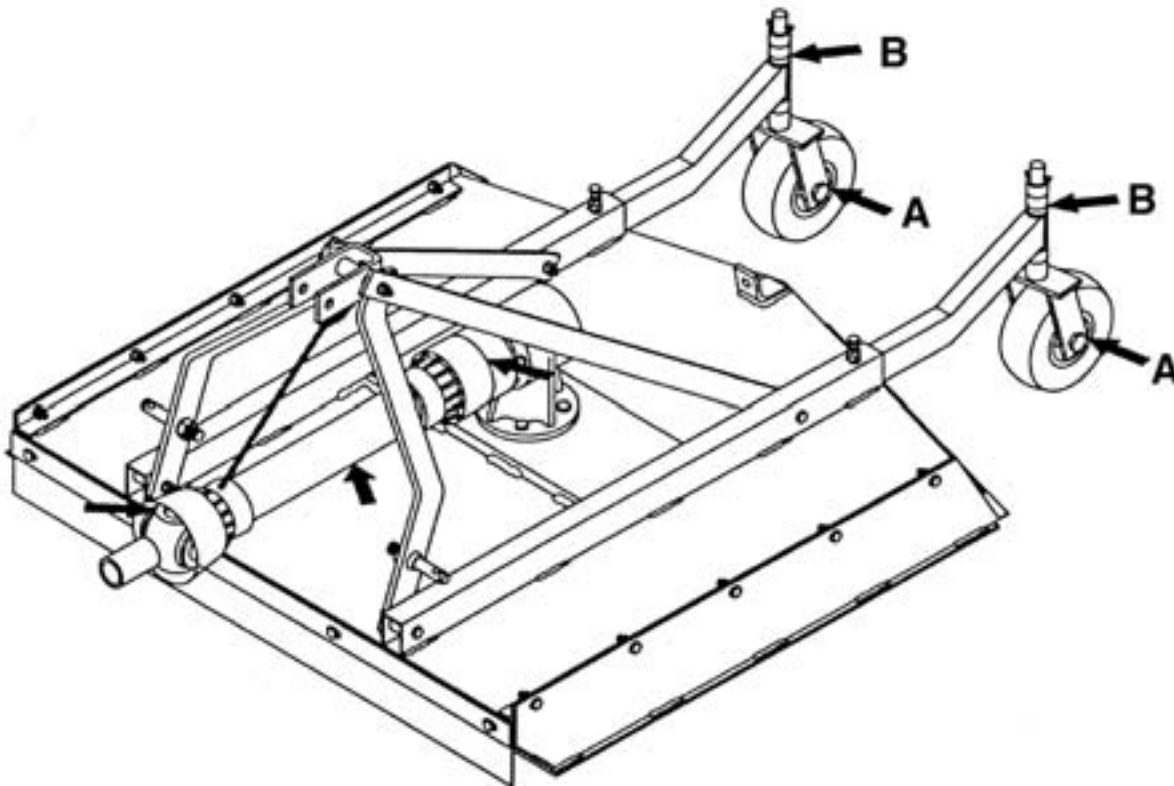

FIGURE B

TAILWHEEL HEIGHT ADJUSTMENT

There are four (4) cutting height adjustment spacers - 1" (Qty. 3) and 1 1/2" (Qty. 1).

1. Raise Rotary Mower off the ground with the tractor and securely block in position.
2. Remove pin from top of wheel fork assembly. Lower wheel fork assembly (Ref. A) from tailwheel arm.
3. Arrange spacers (Ref. B) until desired cutting height is achieved. Cutting heights range from approximately 2.0 to 6.0 inches in height.
4. Re-install wheel fork assembly into tailwheel arm.
5. Repeat adjustment process on remaining wheel fork assembly.
NOTE: Make sure all tailwheels are adjusted to the same height for an even cut.



PREPARATION



READ THIS BEFORE OPERATING MOWER



TRAINING

Know your controls and how to stop tractor engine and mower quickly in an emergency. ***READ THIS OPERATOR'S MANUAL AND THE MANUAL PROVIDED WITH YOUR TRACTOR.***

To avoid accident or injury, ***do not*** allow anyone to operate this equipment without proper instructions. Any person who operates this equipment must be instructed in and be capable of the safe operation of the unit, its attachments and all controls.

DO NOT allow children to operate machine, or adults to operate it without proper instructions.

BEFORE OPERATION

- ***Always*** wear relatively tight and belted clothing when operating mower. Loose clothing should not be worn, as it could get caught in the moving parts or controls. Wear sturdy, rough-soled work shoes and protective equipment for eyes, hands, hearing and head. ***Never*** operate tractor or implements in bare feet, sandals or sneakers.
- ***Never*** permit any person other than the operator to ride on board the tractor at any time. ***DO NOT*** allow riders on mower at any time.
- Clear area of stones, branches or other debris that might be thrown, causing injury or damage.
- Operate only in daylight or good artificial light.
- Ensure mower is properly mounted, adjusted and in good operating condition.
- Ensure all PTO and other safety shielding is properly installed and in good condition.

OPERATIONAL SAFETY

- Guards and safety shields are for *your* protection. **DO NOT** operate equipment unless they are in place.
- Read and observe **all safety decals** on the tractor and mower (see page 8).
- **Always** operate tractor PTO (power take-off) at recommended RPM (revolutions per minute).
- Stay away from PTO shaft and mower when engaging PTO.
- Disengage tractor PTO and shift into neutral before attempting to start engine.
- **NEVER** allow anyone within 25' of machine while it is in operation.
- **DO NOT** stop or start suddenly when going uphill or downhill. Avoid operation on steep slopes.
- Be alert for holes in terrain and other hidden hazards. **Always** drive slowly over rough ground.
- Reduce speed on slopes and in sharp turns to prevent tipping or loss of control. Be careful when changing direction on slopes.
- Stop mower and tractor immediately upon striking an obstruction. Turn off engine, inspect mower and repair any damage before resuming operation.
- Disengage power to mower and stop engine before dismounting from tractor, before making any repairs or adjustments, transporting, or unclogging mower.
- Take all possible precautions when leaving tractor unattended. Disengage PTO, lower mower, shift into neutral, set parking brake, stop engine and remove key from ignition.

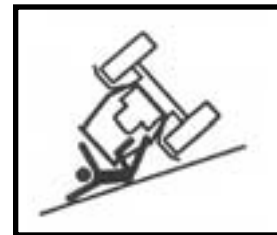

OPERATIONAL SAFETY

Continued...

- Front tractor weights or front tire ballast should be used to enhance front end stability on small tractors.

- **NEVER** operate mower in raised position.

- Check to make sure PTO is properly connected and that the driveline is correct to prevent bottoming out or pulling apart during the full lift range of the hitch.



- This implement is designed for a one-man operation. It is the responsibility of the tractor operator to see that no one is in the proximity of the implement when it is started. **DO NOT** operate the implement when another person is within 25' of the implement.

- **NEVER** put hands or feet under mower deck while tractor engine or mower is running.

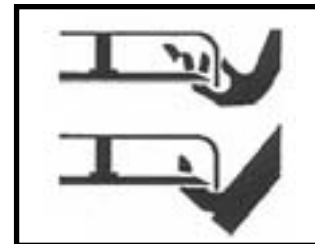

MAINTENANCE SAFETY

- Support the mower with safety stands or blocks before working beneath it.
- Follow good shop practices:

A. Keep service area clean and dry.



B. Be sure electrical outlets and tools are properly grounded.

C. Use adequate light for the job at hand.



- Use only tools, jacks and hoists of sufficient capacity for the job.
- **NEVER** work on the mower unless the tractor engine is off and the driveline is disconnected.
- **ALWAYS** wear heavy canvas or leather gloves when handling mower blades.
- **NEVER** wear loose or frayed clothing when working on moving parts. (i.e. gearbox, blade pan, driveline, etc.)
- Make sure all guards are in place and properly secured when all maintenance work is completed.

MOWER SAFETY DECALS

1. Keep all safety decals and signs clean and legible at all times.
2. Replace safety decals and signs that are missing or have become illegible. (Contact Gearmore at 909.548.4848 for *free* replacement safety decals.)

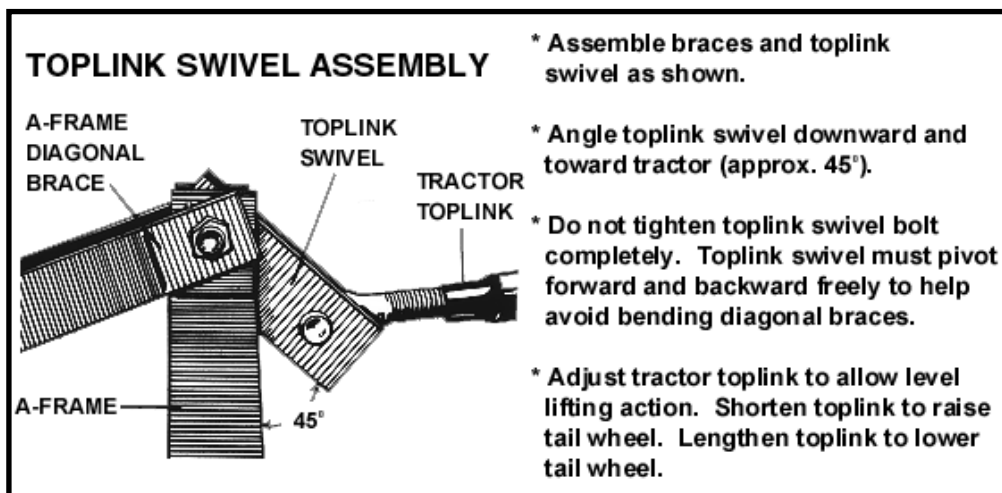

GENERAL MAINTENANCE

Carefully follow all instructions as stated in this manual. This includes operation, lubrication, safety and maintenance. This mower was designed and built for years of reliable service if properly cared for. However, rotary mowers are a high RPM machine, thus daily attention is required.

- ✓ Check all bolts for tightness.
- ✓ Check to make sure all safety guards are in place.
- ✓ Check to remove any trash build-up.
- ✓ Check lubrication - *see lubrication section.*
- ✓ Check blades to make sure they are securely fastened.

SERVICING BLADES

When replacing or grinding blades, both blades must be replaced or re-ground at the same time to maintain the proper balance in the mower. Gearmore mowers are equipped with special heat-treated alloy steel blades. Use only Gearmore blades, substitutes may be dangerous. **NEVER** try to straighten or weld blades.

LUBRICATION

DRIVESHAFT - The driveshaft must be lubricated before mower is put into use. After that, grease every **8 hours** of use or when required. It is also necessary, from time to time, to untelescope the driveshaft to clean and re-grease tubing.

GEARBOX - Check gearbox oil level through square headed screw plug. Add SAE 90 weight oil when required. Change gearbox oil after every **400 hours** of use.

TAILWHEEL - Grease every **8 hours** of use or when required.

TAILWHEEL FORKS - Grease *weekly* or when required.

To comply with OSHA AG Guarding Standard #1928.27, the following guards and shields **must** be kept in place and in good working condition:

1. Safety rubber shielding
2. Driveshaft shields
3. Guards over moving parts

BE CAREFUL AND ALWAYS THINK SAFETY FIRST!

TROUBLESHOOTING

PROBLEM	CAUSE	SOLUTION
Excessive vibration	Blades are not free to swing.	Check bushings and movements of blades.
	Blades are out of balance.	Check blades for damage or replace.
Unusual noise	Loose blade bolts or worn bushings.	Tighten blade bolts, check bushings for wear and change as needed.
	Bent blade carrier, blades striking deck.	Replace blade carrier.
	Deck bent causing blades to hit.	Straighten deck.
	Gearbox low of oil.	Check seals in gearbox and fill to proper level.
Poor cutting	Not maintaining proper PTO speed.	Check PTO with tachometer and operate at proper RPM.
	Improperly adjusted.	Adjust according to Operators Manual.
	Forward speed too fast.	Coordinate forward speed with blade speed.
	Dull blades.	Sharpen blades.
PTO turns and blades do not	Gears stripped in gearbox.	Replace or repair gearbox.
	Shear bolt sheared.	Replace shear bolt.
PTO will not telescope	Improper lubrication.	Separate and fill female tube half full of grease.
	PTO twisted.	Replace twisted portion.
	Bent PTO.	PTO too long. Size to tractor according to manual.
	Shields damaged.	Replace.
PTO twisted	Over torqued.	Caution operator not to ground out machine.
	Not maintaining correct PTO speed.	Maintain proper PTO speed.
Machine streaking	Cutting too high, leaving wheel tracks.	Cut lower and slow forward speed down.
	Not maintaining proper RPM speed.	Maintain proper RPM speed.

MOWER ASSEMBLY

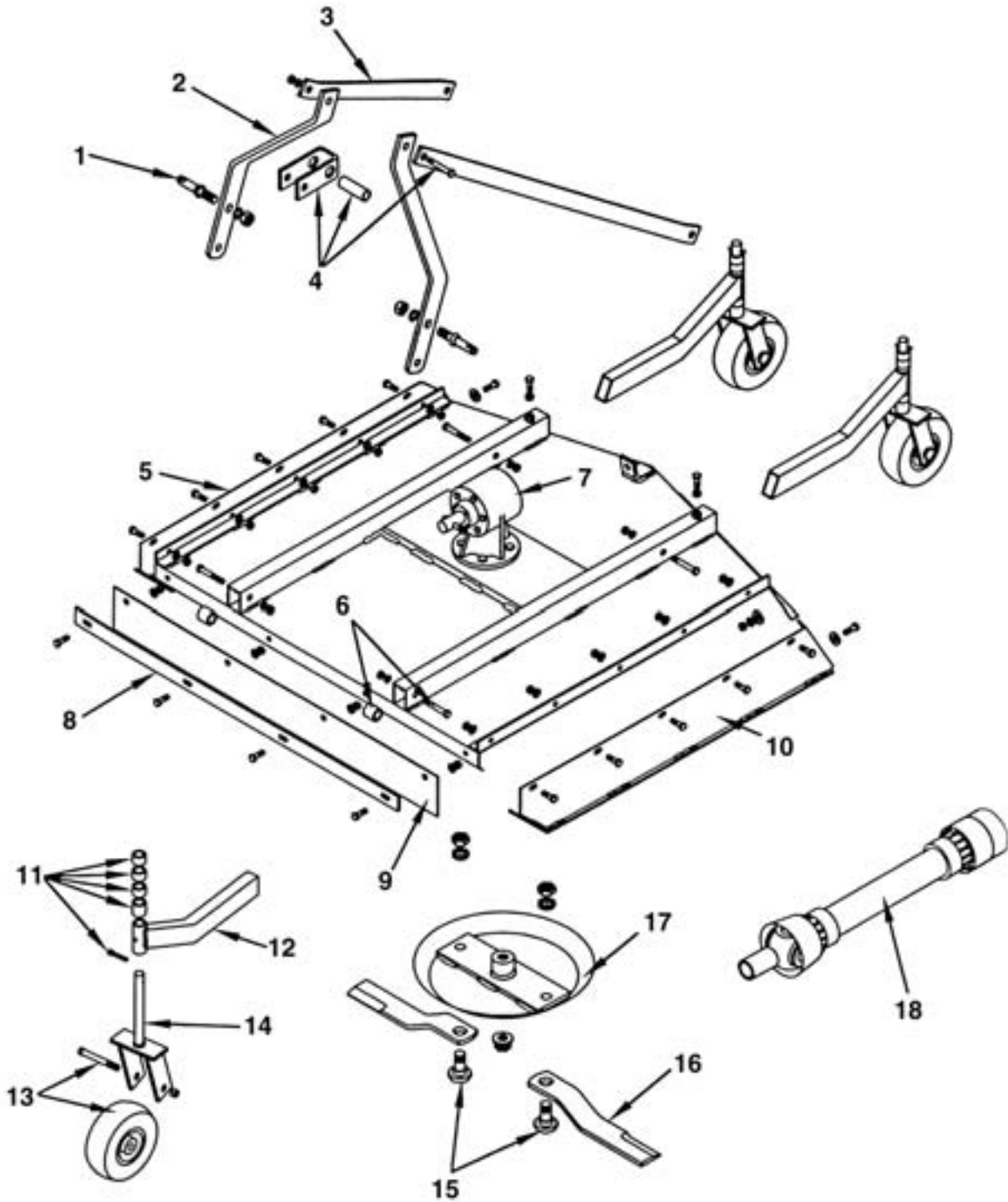

MOWER ASSEMBLY

<u>REF#</u>	<u>QTY.</u>	<u>PART NO.</u>	<u>DESCRIPTION</u>
1	1	500001	Cat. I Lift Pins (Pkg. of 2)
2	2	311100	Lift Arm
3	2	311099	Left Lift Arm Brace
4	1	501027	Swivel Link Kit (Incl. bolt)
5	1	501003	Right Side Panel Kit (Incl. bolts)
6	2	501005	Lift Arm Attachment Kit (Incl. bolts)
7	1	184000	Gearbox
8	1	501006	Belt Guard Kit (Incl. belt and strip)
9	1	311101	Belt Guard
10	1	501004	Left Side Panel Kit (Incl. bolts)
11	2	501007	Tailwheel Arm Spacer Kit
12	2	403700	Tailwheel Arm
13	2	501008	Wheel Kit (Incl. axle bolt)
14	2	403026	Tailwheel Arm Fork
15	1	501001	Blade Bolt Set (Pkg. of 2)
16	2	190118	Mower Blade
17	1	403031	Stump Jumper
18	1	147029	34" PTO Shaft

GEARBOX ASSEMBLY

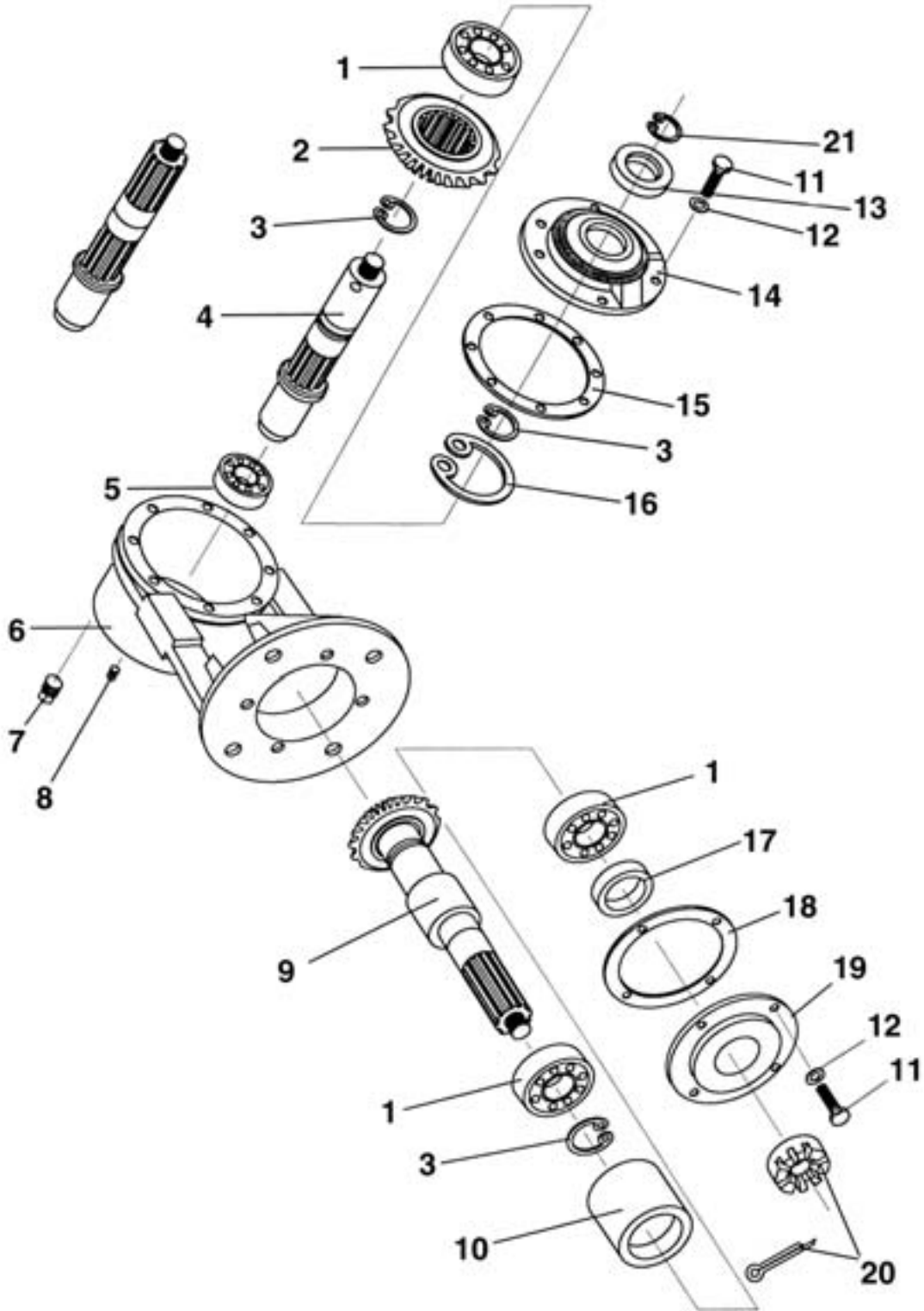

GEARBOX ASSEMBLY

<u>REF#</u>	<u>QTY.</u>	<u>PART NO.</u>	<u>DESCRIPTION</u>
1	3	155005	Bearing
2	1	185007	Input Gear
3	2	131031	Snap Ring
4	1	186010	Input Shaft
5	1	6207	Bearing
6	1	129010	Housing
7	1	131035	1/2" Pipe Plug
8	1	131040	1/8" Pipe Plug
9	1	185005	Output Shaft
10	1	131045	Spacer
11		O/L	3/8" x 1 3/4" bolt
12		O/L	3/8" Lockwasher
13	1	156010	Input Seal 35 x 54 x 10
14	1	129015	Front Cap
15	1	124130	Front Cap Gasket
16	1	131030	Snap Ring
17	1	156005	Output Seal 40 x 54 x 7
18	1	124131	Bottom Cap Gasket
19	1	129005	Bottom Cap
20	1	501110	1" Castle Nut w/Washer & Cotter Pin
21	1	106138	Input Shaft Snap Ring

PTO DRIVELINE 147029

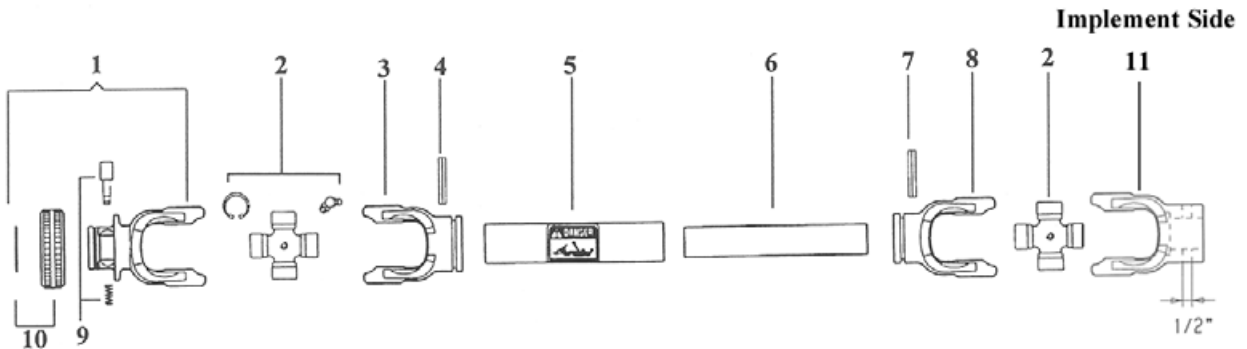

<u>REF#</u>	<u>QTY.</u>	<u>PART NO.</u>	<u>DESCRIPTION</u>
1	1	572040351	RS collar Yoke 1-3/8 6-Spline
2	2	41204	Cross Kit Assembly #4
3	1	204046851	Outer Tube Yoke #4
4	1	341038000	Roll Pin O.T. #4
5	1	225101200	Outer Drive Tube #4
6	1	225121200	Inner Drive Tube #4
7	1	341048000	Roll Pin I.T. #4
8	1	204046852	Inner Tube Yoke #4
9	2	403000001	Quick Disconnect Pin Kit
10	2	211015363	RS Collar 5-6
11	1	211044955	Yoke 1-3/8" Round Bore
	1	5F04120F6	B & P Shield Kit With Bearings
	1	255040006	B & P Shield Bearing Inner
	1	255040005	B & P Shield Bearing Outer
	1	36728	Eurocardan Shield Kit
	1	35069	Eurocardan Bearing Inner
	1	35066	Eurocardan Bearing Outer

LIMITED WARRANTY



GEARMORE, INC., warrants each new Gearmore product to be free from defects in material and workmanship for a period of twelve (12) months from date of purchase to the original purchaser. This warranty shall not apply to implements or parts that have been subject to misuse, negligence, accident, or that have been altered in any way.

Our obligation shall be limited to repairing or replacement of any part, provided that such part is returned within thirty (30) days from date of failure to Gearmore through the dealer from whom the purchase was made, transportation charges prepaid.

This warranty shall not be interpreted to render us liable for injury or damages of any kind or nature, direct, consequential or contingent, to person or property. This warranty does not extend to loss of crops, loss because of delay in harvesting or any other expenses, for any other reasons.

Gearmore in no way warrants engines, tires, or other trade accessories, since these items are warranted separately by these respective manufacturers.

Gearmore reserves the right to make improvements in design or changes in specification at any time, without incurring any obligations to owners or units previously sold.

GEARMORE, INC.
13477 Benson Ave.
Chino, CA 91710

Always refer to and heed machine operating warning decals on machine.

The serial number of this product is stored in our computer database, thus submitting a warranty registration card is not required.