



# **V-RIPPER**

**Operation, Service  
& Parts Manual For  
Model VR3  
Category II, 3-Point**

**February 2001**

# TABLE OF CONTENTS

Introduction/Assembly .....	1
Operating Instructions .....	2
Operational Safety .....	3
V-Ripper Assembly .....	4-5
Limited Warranty .....	6

Date of Purchase: \_\_\_\_\_

Model Number: \_\_\_\_\_

Serial Number \_\_\_\_\_

# INTRODUCTION

*We welcome you as an owner of a Gearmore v-ripper. Please read the following instructions and refer to them when required:*

## ASSEMBLY INSTRUCTIONS

With normal maintenance you should receive years of use out of the v-ripper.

1. Inspect unit to make sure all bolts that hold the shank wing brackets are tight.
2. The shank retainer bolt and the shank shear bolt should not be overtightened. They only need to be tightened enough so that the special nyloc locknut will not back off. Overtightening will cause the mounting plate to squeeze the shank not allowing the shear bolt to shear properly.
3. When ripping, do not turn with the shanks in the ground. Doing so will cause damage to the shanks and frame.
4. Tractors having draft control on their 3-point should be adjusted so that the ripper operates properly when tough ground conditions arise. Review the tractors operators manual for correct settings.
5. Only replace shear bolts with grade 2 bolts. Using a higher grade bolt will only cause damage to the ripper or tractor.
6. Check to make sure that shanks have proper clearance between shank point and tractor tires. Damage to tires will not be covered under warranty.

# OPERATING INSTRUCTIONS



## READ THIS BEFORE OPERATING V-RIPPER

Know your controls and how to stop tractor engine and v-ripper quickly in an emergency. ***READ THIS OPERATOR'S MANUAL AND THE MANUAL PROVIDED WITH YOUR TRACTOR.***

To avoid accident or injury, ***do not*** allow anyone to operate this equipment without proper instructions. Any person who operates this equipment must be instructed in and be capable of the safe operation of the unit, its attachments and all controls.

***DO NOT*** allow children to operate machine, or adults to operate it without proper instructions.

***DO NOT*** make turns with the shanks in the ground. Doing this will cause damage to the shanks and frame.

# OPERATIONAL SAFETY

- Read the operator's manual before using any equipment.
- **NEVER** allow children to operate tractor and v-ripper or other power equipment.
- Know how to stop the tractor quickly in the event of an emergency.
- Instruct children and other persons to stay away from the tractor and v-ripper when it is in operation.
- **ALWAYS** remove the key when leaving the tractor unattended.
- **NEVER** allow v-ripper to be left in the "up" position when unattended.
- Give complete undivided attention to the job at hand.
- **NEVER** allow riders.
- Stop the engine when dismounting from the tractor.
- Use caution when operating the tractor on uneven terrain. Decrease speed when making turns. Use front and rear wheel weights as required.
- Add sufficient amount of weight to front end of tractor to prevent wheels from coming off the ground when starting suddenly with a load.

# V-RIPPER PARTS DRAWING

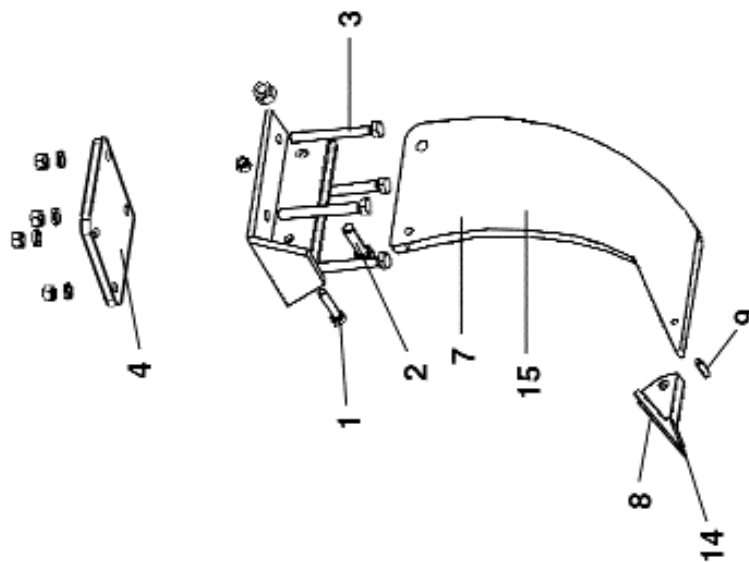
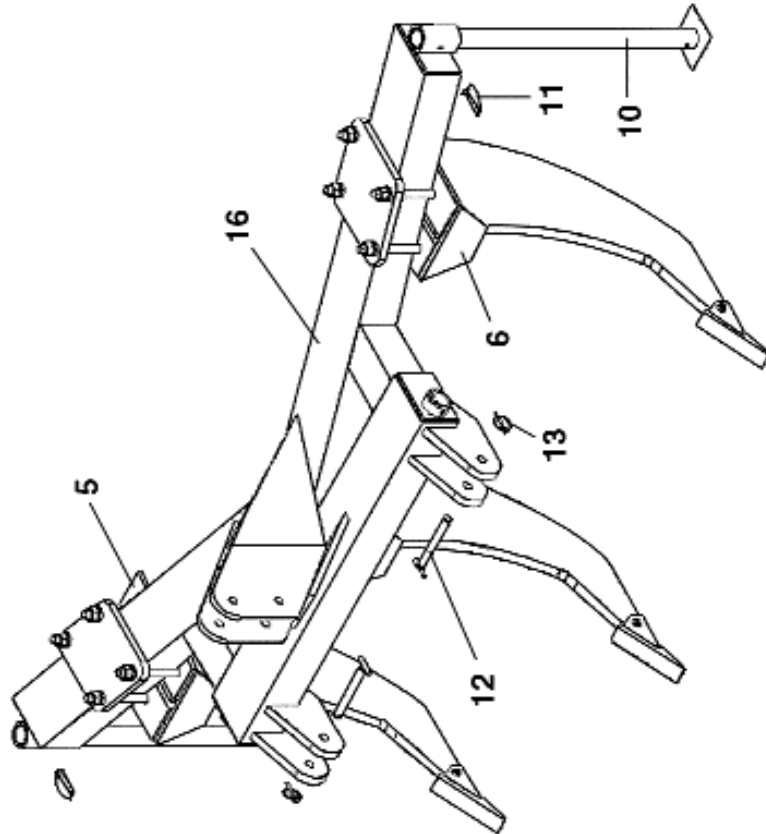

# V-RIPPER PARTS LIST

<u>REF #</u>	<u>PART NUMBER</u>	<u>DESCRIPTION</u>
1	VR8401	Bolt Assy 5/8 x 3 1/2 grade 2
2	VR8402	Bolt Assy 7/8 x 3 1/2 grade 5
3	VR8403	Bolt Assy 3/4 x 7 grade 5
4	VR8404	Clamp Plate 3/4 x 8
5	VR8405	Right Wing Bracket
6	VR8406	Left Wing Bracket
7	VR8407	1" x 27" Shank, Standard Plain
8	VR8408	Point 21F Standard
9	VR8409	Roll Pin 1/2" x 2"
10	VR8410	Parking Stand
11	VR8411	Klick Pin PS
12	VR8412	Cat. 2 Hitch Pin
13	VR8413	Klick Pin
14	VR8408HF	Point Hardfaced
15	VR8415	1" x 27" Hardfaced Shank
16	VR8420	Frame Only

# LIMITED WARRANTY



GEARMORE, INC., warrants each new Gearmore product to be free from defects in material and workmanship for a period of twelve (12) months from date of purchase to the original purchaser. This warranty shall not apply to implements or parts that have been subject to misuse, negligence, accident, or that have been altered in any way.

Our obligation shall be limited to repairing or replacement of any part, provided that such part is returned within thirty (30) days from date of failure to Gearmore through the dealer from whom the purchase was made, transportation charges prepaid.

This warranty shall not be interpreted to render us liable for injury or damages of any kind or nature, direct, consequential or contingent, to person or property. This warranty does not extend to loss of crops, loss because of delay in harvesting or any other expenses, for any other reasons.

Gearmore in no way warrants engines, tires, or other trade accessories, since these items are warranted separately by these respective manufacturers.

Gearmore reserves the right to make improvements in design or changes in specification at any time, without incurring any obligations to owners or units previously sold.

GEARMORE, INC.  
13477 Benson Ave.  
Chino, CA 91710

Always refer to and heed machine operating warning decals on machine.

*The serial number of this product is stored in our computer database, thus submitting a warranty registration card is not required.*