



LOADER PALLET FORKS



**Assembly/Operator's/Parts
Manual For Models
ULF, JLF, KLF, SSF, & SSLF
3542 & 3548**

December 2008

TABLE OF CONTENTS

SECTION	DESCRIPTION	PAGE
1	Introduction	1
1.1	Serial Number Location	1
2	Safety.....	2
2.1	General Safety	3
2.2	Equipment Safety Guidelines	4
2.3	Safety Training	5
2.4	Safety Signs	5
2.5	Preparation	6
2.6	Operating Safety	7
2.7	Transport Safety	8
2.8	Maintenance Safety	8
2.9	Hydraulic Safety	9
2.10	Storage Safety	9
3	Safety Sign Locations.....	10
4	Operation	11
4.1	To the New Operator or Owner	11
4.2	Machine Components	12
4.3	Machine Break-In	12
4.4	Pre-Operation Checklist.....	12
4.5	Mounting Configurations	13-15
4.6	Transporting	16
4.7	Storage	16
5	Trouble Shooting.....	17
6	Assembly.....	18
7	Specifications	19
7.1	Mechanical	19
7.2	Bolt Torque.....	20
8	Parts Diagrams	21
8.1	ULF-3542 (3548) Pallet Fork Assy	21
8.2	JLF-3542 (3548) Pallet Fork Assy	22
8.3	KLF-3542 (3548) Pallet Fork Assy	23
8.4	SSF-3542 (3548) Pallet Fork Assy	23
9	Limited Warranty.....	25

1 INTRODUCTION

Congratulations on your choice of Loader Pallet Forks to complement your pallet moving and storage operation. This equipment has been designed and manufactured to meet the needs of a discriminating buyer for the efficient lifting and moving of pallets.

Safe, efficient and trouble free operation of your Loader Pallet Forks requires that you and anyone else who will be operating or maintaining the machine, read and understand the Safety, Operation, Maintenance and Troubleshooting information contained within the Operator's Manual.

This manual covers the Loader Pallet Forks Models ULF-3542, ULF-3548, JLF-3542, JLF-3548, KLF-3542, KLF-3548, SSF-3542, & SSF-3548. Differences are explained where appropriate. Use the Table of Contents as a guide to locate required information.

Keep this manual handy for frequent reference and to pass on to new operators or owners. Call your Gearmore dealer or distributor if you need assistance, information or additional copies of the manuals.

OPERATOR ORIENTATION - The directions left, right, front and rear, as mentioned throughout this manual, are as seen from the driver's seat and facing in the direction of travel.

1.1 SERIAL NUMBER LOCATION

Always give your dealer the serial number of your Loader Pallet Forks when ordering parts or requesting service or other information.

The serial number plate is located where indicated. Please mark the number in the space provided for easy reference.



DATE OF PURCHASE: _____

MODEL NUMBER: _____

SERIAL NUMBER: _____

2 SAFETY

SAFETY ALERT SYMBOL

This Safety Alert symbol means **ATTENTION! BECOME ALERT! YOUR SAFETY IS INVOLVED!**



The Safety Alert symbol identifies important safety messages on the Loader Pallet Forks and in the manual. When you see this symbol, be alert to the possibility of personal injury or death. Follow the instructions in the safety message.

Why is SAFETY important to you?

3 Big Reasons

Accidents Disable and Kill

Accidents Cost

Accidents Can Be Avoided

SIGNAL WORDS:

Note the use of the signal words **DANGER**, **WARNING** and **CAUTION** with the safety messages. The appropriate signal word for each message has been selected using the following guide-lines:

SI NO LEE INGLES, PIDA AYUDA A AIGUIEN QUE SI LO LEA PARA QUE LE TRADUZCA LAS MIDIDAS DE SEGURIDAD.

DANGER - Indicates an imminently hazardous situation that, if not avoided, will result in death or serious injury. This signal word is to be limited to the most extreme situations typically for machine components which, for functional purposes, cannot be guarded.

WARNING - Indicates a potentially hazardous situation that, if not avoided, could result in death or serious injury, and includes hazards that are exposed when guards are removed. It may also be used to alert against unsafe practices.

CAUTION - Indicates a potentially hazardous situation that, if not avoided, may result in minor or moderate injury. It may also be used to alert against unsafe practices.

If you have any questions not answered in this manual or require additional copies or the manual is damaged, please contact your dealer.

2.1 GENERAL SAFETY

YOU are responsible for the **SAFE** operation and maintenance of your Loader Pallet Forks. **YOU** must ensure that you and anyone else who is going to operate, maintain or work around the Forks be familiar with the operating and maintenance procedures and related **SAFETY** information contained in this manual. This manual will take you step-by-step through your working day and alerts you to all good safety practices that should be adhered to while operating the Forks.

Remember, **YOU** are the key to safety. Good safety practices not only protect you, but also the people around you. Make these practices a working part of your safety program. Be certain that **EVERYONE** operating this equipment is familiar with the recommended operating and maintenance procedures and follows all the safety precautions. Most accidents can be prevented. Do not risk injury or death by ignoring good safety practices.

- **Loader Pallet Forks attachment is designed to engage and load palletized materials. Do not use forks to handle large loads such as bales, posts, etc. and avoid carrying loose or shiftable loads.**
- Fork owners must give operating instructions to operators or employees before allowing them to operate the machine, and at least annually there after per OSHA (Occupational Safety and Health Administration) regulation 1928.57.
- The most important safety feature on this equipment is a **SAFE** operator. It is the operator's responsibility to read and understand **ALL** Safety and Operating instructions in the manual and to follow these. Most accidents can be avoided.
- A person who has not read and understood all operating and safety instructions is not qualified to operate the machine. An untrained operator exposes himself and bystanders to possible serious injury or death.
- **DO NOT** modify the equipment in any way. Unauthorized modification may impair the function and/or safety and could affect the life of the equipment.

1. Read and understand the Operator's Manual and all safety signs before operating, maintaining or adjusting the Loader Pallet Forks.



2. Have a first-aid kit available for use should the need arise and know how to use it.



3. Have a fire extinguisher available for use should the need arise and know how to use it.

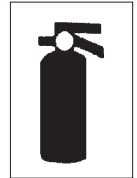

4. Wear appropriate protective gear. This list includes but is not limited to:

- A hard hat
- Protective shoes with slip resistant soles
- Protective goggles, glasses or face shield
- Heavy gloves
- Protective clothing

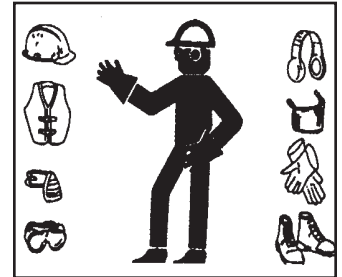

5. Install and secure all guards before starting.

6. **DO NOT** allow riders.

7. Wear suitable ear protection for prolonged exposure to excessive noise.



8. Lower bucket/forks to the ground, set park brake, remove ignition key and wait for all moving parts to stop before servicing, adjusting and repairing.

9. Clear the area of people, especially small children, before starting.

10. Review safety related items annually with all personnel who will be operating or maintaining the Loader Pallet Forks.

2.2 EQUIPMENT SAFETY GUIDELINES

Safety of the operator and bystanders is one of the main concerns in designing and developing a machine. However, every year many accidents occur which could have been avoided by a few seconds of thought and a more careful approach to handling equipment. You, the operator, can avoid many accidents by observing the following precautions in this section. To avoid personal injury or death, study the following precautions and insist those working with you, or for you, follow them.

- In order to provide a better view, certain photographs or illustrations in this manual may show an assembly with a safety shield removed. However, equipment should **never** be operated in this condition. Keep all shields in place. If shield removal becomes necessary for repairs, replace the shield prior to use.
- Replace any safety sign or instruction sign that is not readable or is missing. Location of such safety signs is indicated in this manual.
- **NEVER** use alcoholic beverages or drugs which can hinder alertness or coordination while operating this equipment. Consult your doctor about operating this machine while taking prescription medications.
- **Under no circumstances should young children be allowed to work with this equipment. Do not allow persons to operate or assemble this unit until they have read this manual and have developed a thorough understanding of the safety precautions and of how it works.** Review the safety instructions with all users annually.

- This equipment is dangerous to children and persons unfamiliar with its operation. The operator should be a responsible, properly trained and physically able person familiar with farm machinery and trained in this equipment's operations. If the elderly are assisting with farm work, their physical limitations need to be recognized and accommodated.
- Use a tractor equipped with a Roll Over Protective Structure (ROPS) and a seat belt.
- **NEVER** exceed the limits of a piece of machinery. If its ability to do a job, or to do so safely, is in question - **DON'T TRY IT.**
- Do not modify the equipment in any way. Unauthorized modification may impair the function and/or safety and could affect the life of the equipment.

In addition to the design and configuration of this implement, including Safety Signs and Safety Equipment, hazard control and accident prevention are dependent upon the awareness, concern, prudence and proper training of personnel involved in the operation, transport, maintenance and storage of the machine. Refer also to Safety Messages and operation instruction in each of the appropriate sections of the tractor and machine manuals. Pay close attention to the Safety Signs affixed to the tractor and the machine.

Think SAFETY! Work SAFELY!

2.3 SAFETY TRAINING

Safety is a primary concern in the design and manufacture of our products. Unfortunately, our efforts to provide safe equipment can be wiped out by a single careless act of an operator or bystander.

In addition to the design and configuration of equipment, hazard control and accident prevention are dependent upon the awareness, concern, prudence and proper training of personnel involved in the operation, transport, maintenance and storage of this equipment.

It has been said, "***The best safety feature is an informed, careful operator.***" We ask you to be that kind of an operator. It is the operator's responsibility to read and understand ALL Safety and Operating instructions in the manual and to follow these. Accidents can be avoided.



Working with unfamiliar equipment can lead to careless injuries. Read this manual, and the manual for your tractor, before assembly or operating, to acquaint yourself with the machines. If this machine is used by any person other than yourself, or is loaned or rented, it is the machine owner's responsibility to make certain that the operator, prior to operating:

- a. Reads and understands the operator's manuals.
- b. Is instructed in safe and proper use.

Know your controls and how to stop tractor, engine and machine quickly in an emergency. Read this manual and the one provided with your tractor.

Train all new personnel and review instructions frequently with existing workers. Be certain only a properly trained and physically able person will operate the machinery. A person who has not read and understood all operating and safety instructions is not qualified to operate the machine. An untrained operator exposes himself and bystanders to possible serious injury or death. If the elderly are assisting with farm work, their physical limitations need to be recognized and accommodated.

2.4 SAFETY SIGNS

1. Keep safety signs clean and legible at all times.
2. Replace safety signs that are missing or have become illegible.
3. Replaced parts that displayed a safety sign should also display the current sign.
4. Safety signs are available from your authorized dealer or from Gearmore.

How To Install Safety Signs:

- Be sure that the installation area is clean and dry.
- Be sure temperature is above 50° F (10° C).
- Determine exact position before you remove the backing paper. (*See Section 3*)
- Remove the smallest portion of the split backing paper.
- Align the sign over the specified area and carefully press the small portion with the exposed sticky backing in place.
- Slowly peel back the remaining paper and carefully smooth the remaining portion of the sign in place.
- Small air pockets can be pierced with a pin and smoothed out using the piece of sign backing paper.

2.5 PREPARATION

1. Never operate the tractor and machine until you have read and completely understand this manual, the Tractor Operator's Manual and each of the Safety Messages found on the safety signs on the tractor and machine.

2. Personal protection equipment, including hard hat, safety glasses, safety shoes and gloves are recommended during assembly, installation, operation, adjustment, maintaining, repairing, removal or moving the implement. **DO NOT** allow long hair, loose fitting clothing or jewelry to be around equipment.

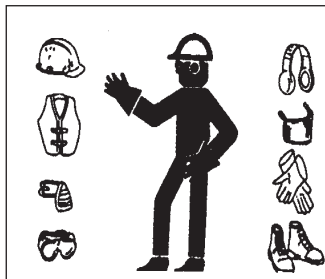

3. **PROLONGED EXPOSURE TO LOUD NOISE MAY CAUSE PERMANENT HEARING LOSS!**

Tractors with or without equipment attached can often be noisy enough to cause permanent, partial hearing loss. We recommend that you wear hearing protection on a full-time basis if the noise in the Operator's position exceeds 80db. Noise over 85db on a long-term basis can cause severe hearing loss. Noise over 90db adjacent to the Operator over a long-term basis may cause permanent, total hearing loss. **NOTE:** Hearing loss from loud noise (from tractors, chain saws, radios, and other such sources close to the ear) is cumulative over a lifetime without hope of natural recovery.

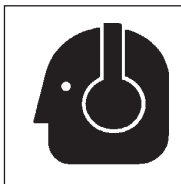

4. Operate the machine only with a tractor equipped with an approved Roll-Over Protective Structure (ROPS). Always wear your seat belt. Serious injury or even death could result from falling off the tractor --- particularly during a turn-over when the operator could be pinned under the ROPS or the tractor.
- 
5. Clear working area of stones, branches or hidden obstacles that might be hooked or snagged, causing injury or damage.
 6. Keep bucket/forks away from overhead power lines. Electrocutation can occur without direct contact with an overhead power line.
 7. Operate only in daylight or good artificial light.
 8. Be sure machine is properly mounted, adjusted and in good operating condition.
 9. Before starting, give the machine a "once over" for any loose bolts, worn parts, cracks, leaks, frayed hoses and make necessary repairs. Always follow maintenance instructions.
 10. Ensure that all safety shielding and safety signs are properly installed and in good condition.
 11. Check that mounting pins are in good condition and all locking pins are installed.
 12. Move wheels or tires to their widest position for maximum stability.
 13. Add wheel ballast or rear weight for maximum stability.
 14. Do not use on tractors with narrow front ends. Use wide front axle only.

2.6 OPERATING SAFETY

Please remember it is important that you read and heed the safety signs on the Loader and Forks. Clean or replace all safety signs if they cannot be clearly read and understood. They are there for your safety, as well as the safety of others. The safe use of this machine is strictly up to you, the operator.

All things with moving parts are potentially hazardous. There is no substitute for a cautious, safe-minded operator who recognizes potential hazards and follows reasonable safety practices. The manufacturer has designed these Forks to be used with all its safety equipment properly attached to minimize the chance of accidents. Study this manual to make sure you have all safety equipment attached.

Fork attachments are designed to engage and load palletted material. Do not use Forks to handle large loads such as bales, posts, etc. and avoid carrying loose or shiftable loads.

Practice raising, lowering and tilting unit and its load when learning to operate Loader and Forks. Become familiar with controls before operating.

If a safety shield or guard is removed for any reason, it must be replaced before the machine is again operated.

Keep the Loader arms and Forks at a low position when moving and when working on inclines.

Do not operate near the edge of drop-offs or banks.

Do not operate at an angle on steep slopes. Drive up or down but not across. Keep bucket, forks and arms low.

Make allowances for increased length and weight of tractor during operation and moving.

Remove all sticks, stones, roots and wires from working area before starting. Take care not to contact overhead obstructions during operation.

Never operate controls from the ground. Operate only from the operators seat to prevent unexpected loader and fork movement that can lead to crushing between frame members.

Use extra care when handling large round loads or other shiftable objects unless loader and forks are equipped with an attachment designed to secure objects. A grapple fork anchor device is recommended.

Large round loads or loose objects can roll back down loader arms. Secure objects before raising arms. Keep arms low.

Keep bucket/forks away from overhead power lines. Electrocutation can occur without direct contact with an overhead power line.

Do not exceed machine lift capacity. Overloading can cause structural damage and lead to unsafe operating conditions.

Never carry, lift or move people on arms, forks or bucket. Do not use machine as a work platform.

Always use two people to handle heavy, unwieldy components during assembly, installation, removal or moving.

Never place any part of your body where it would be in danger if movement should occur during assembly, installation, operation, maintaining, repairing, removal or moving.

Do not walk or work under a raised machine or attachment unless it is securely blocked or held in position. Do not depend on the tractor hydraulic system to hold the machine or attachment in place.

Never use alcoholic beverages or drugs, which can hinder alertness or coordination, while operating this equipment. Consult your doctor about operating this machine while taking prescription medications.

Do not allow riders on the machine or tractor at any time. There is no safe place for any riders.

Do not go under raised loader or forks. Keep others away.

Before you operate the machine, check over all pins, bolts and connections to be sure all are securely in place. Replace any damaged or worn parts immediately.

Review safety instructions annually.

2.7 TRANSPORT SAFETY

1. Comply with state and local laws governing highway safety and movement of farm machinery on public roads.
2. The use of flashing amber lights is acceptable in most localities. However, some localities prohibit their use. Local laws should be checked for all highway lighting and marking requirements.
3. At all times, when driving the tractor and equipment on the road or highway under 20 mph (32 kph) use flashing amber warning lights and a slow moving vehicle (SMV) identification emblem. Do not exceed 20 mph (32 kph). Reduce speed on rough roads and surfaces.
4. Keep tractor in gear to provide engine braking when going downhill. Do not coast.
5. Plan your route to avoid heavy traffic.
6. Keep brake pedals latched together at all times.
7. Do not drink and drive.
8. Be a safe and courteous driver. Always yield to oncoming traffic in all situations, including narrow bridges, intersections, etc. Watch for traffic when operating near or crossing roadways.
9. Turn into curves or go up or down hills only at a low speed and at a gradual steering angle. Make certain that at least 20% of the tractor's weight is on the front wheels to maintain safe steering. Slow down on rough or uneven surfaces.
10. Keep loader in a low position when traveling. Remember, the higher the loader, the higher the center of gravity with increased risk of the unit upset.
11. Never allow riders on either tractor or machine.

2.8 MAINTENANCE SAFETY

1. Good maintenance is your responsibility. Poor maintenance is an invitation to trouble.
2. Follow good shop practices.
 - Keep service area clean and dry.
 - Be sure electrical outlets and tools are properly grounded.
 - Use adequate light for the job at hand.
3. Make sure there is plenty of ventilation. Never operate the engine in a closed building. The exhaust fumes may cause asphyxiation.
4. Before working on this machine, lower loader arms and forks to the ground, shut off the engine, set the brakes and remove the ignition key.
5. Never work under equipment unless it is blocked securely.
6. Use personal protection devices such as eye, hand and hearing protectors, when performing any service or maintenance work.
7. Where replacement parts are necessary for periodic maintenance and servicing, genuine factory replacement parts **must** be used to restore your equipment to original specifications. The manufacturer will not be responsible for injuries or damages caused by use of unapproved parts and/or accessories.
8. A fire extinguisher and first aid kit should be kept readily accessible while performing maintenance on this equipment
9. Periodically tighten all bolts, nuts and screws and check that all cotter pins are properly installed to ensure unit is in a safe condition.
10. When completing a maintenance or service function, make sure all safety shields and devices are installed before placing unit in service.

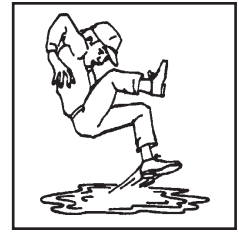

2.9 HYDRAULIC SAFETY

- Make sure that all the components in the hydraulic system are kept in good condition and are clean.
- Replace any worn, cut, abraded, flattened or crimped hoses and metal lines.
- Relieve pressure before working on hydraulic system.
- Do not attempt any makeshift repairs to the hydraulic lines, fittings or hoses by using tapes, clamps or cements. The hydraulic system operates under extremely high pressure. Such repairs will fail suddenly and create a hazardous and unsafe condition.
- Wear proper hand and eye protection when searching for a high pressure hydraulic leak. Use a piece of wood or cardboard as a backstop instead of hands to isolate and identify a leak.
- If injured by a concentrated high pressure stream of hydraulic fluid, seek medical attention immediately. Serious infection or toxic reaction can develop from hydraulic fluid piercing the skin surface.
- Before applying pressure to the system, make sure all components are tight and that lines, hoses and couplings are not damaged.
- When disconnecting hydraulic lines, shut off hydraulic supply and relieve hydraulic pressure.

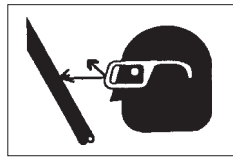

2.10 STORAGE SAFETY

1. Store the unit in an area away from human activity
2. Do not permit children to play on or around the stored machine.
3. Store the unit in a dry, level area. Support the frame with planks if required.

SAFETY RECAP

The manufacturer follows the general Safety Standards specified by the American Society of Agricultural Engineers (ASAE) and the Occupational Safety and Health Administration (OSHA). Anyone who will be operating and/or maintaining the Loader Pallet Forks must read and clearly understand ALL Safety, Operating and Maintenance information presented in this manual.

Do not operate or allow anyone else to operate this equipment until such information has been reviewed. Annually review this information before the season start-up.

Make these periodic reviews of SAFETY and OPERATION a standard practice for all of your equipment. We feel that an untrained operator is unqualified to operate this machine.



Think SAFETY! Work SAFELY!

3 SAFETY SIGN LOCATION

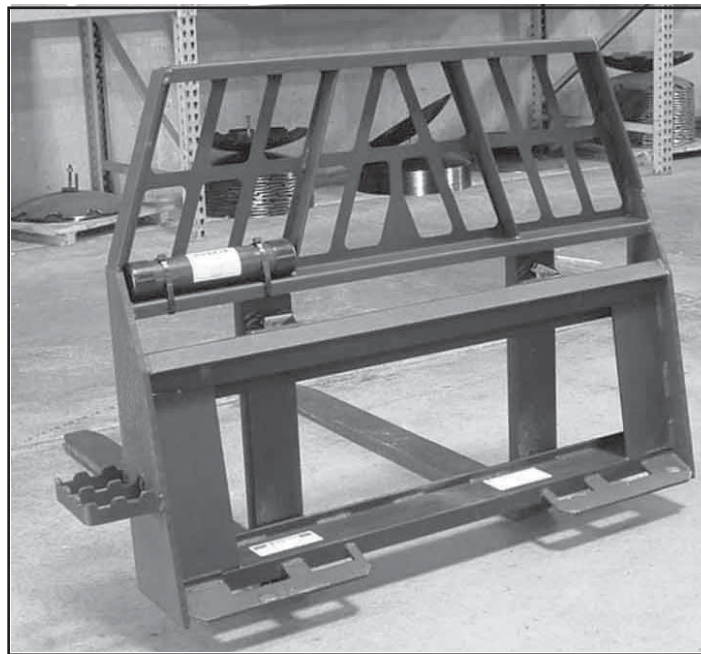



The types of safety signs and locations on the equipment are shown in the illustration below. Good safety requires that you familiarize yourself with the various safety signs, the type of warning and the area, or particular function related to that area, that requires your SAFETY AWARENESS.



A

 <h2 style="margin: 0;">CAUTION</h2>	<ul style="list-style-type: none"> • Read Operator's Manual. • Lower bucket/forks to the ground, stop engine, set park brake, remove ignition key and wait for all moving parts to stop before servicing, adjusting and repairing. • Do not carry people in bucket or on frame. • Add weight to rear of frame to balance bucket load. • Stay away from overhead power lines. Electrocutation can occur without direct contact. 	<ul style="list-style-type: none"> • Widen wheels or tires to prevent tipping. • Use only with a unit with ROPS and a seat belt. • Secure load in bucket to prevent roll-back down loader arms. • Carry load close to the ground when moving. • Do not go under raised bucket. Keep others away. • Review safety instructions.
 <p>Fork attachments are designed to engage and load palletized materials. Do not use forks to handle large loads such as bales, posts, etc. and avoid carrying loose or shiftable loads.</p>	CAUT002	

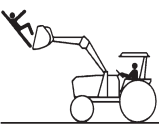
B

 <h2 style="margin: 0;">DANGER</h2>				
				
				DANG001

REMEMBER - If safety signs have been damaged, removed, become illegible or parts replaced without signs, new signs must be applied. New signs are available from your authorized dealer.

4 OPERATION



OPERATING SAFETY

1. Read Operator's Manual.
2. Lower bucket/forks to the ground, stop engine, set park brake, remove ignition key and wait for all moving parts to stop before servicing, adjusting and repairing.
3. Do not carry people in bucket or on frame.
4. Add weight to rear of frame to balance bucket load.
5. Stay away from overhead power lines. Electrocution can occur without direct contact.
6. Widen wheels or tires to prevent tipping.
7. Use only with a unit with ROPS and a seat belt.
8. Secure load in bucket to prevent roll-back down loader arms.
9. Carry load close to the ground when moving.
10. Do not go under raised bucket. Keep others away.
11. Review safety instructions.

4.1 TO THE NEW OPERATOR OR OWNER

Loader Pallet Forks are designed as light to medium duty forks to engage and load palletized materials. Do not use forks to handle large loads such as bales, posts, etc. and avoid carrying loose or shiftable loads. Be familiar with the machine before starting.

It is the responsibility of the owner or operator to read this manual and to train all other operators before they start working with the machine. Follow all safety instructions exactly. Safety is everyone's business. By following recommended procedures, a safe working environment is provided for the operator, bystanders and the area around the worksite. Untrained operators are not qualified to operate the machine.

Many features incorporated into this machine are the result of suggestions made by customers like you. Read this manual carefully to learn how to operate the machine safely and how to set it to provide maximum field efficiency. By following the operating instructions in conjunction with a good maintenance program, your Loader Pallet Forks will provide many years of trouble free service.

4.2 MACHINE COMPONENTS

Loader Pallet Forks are attached to a frame that mounts in the place of the loader bucket and is used to lift, move and transport pallets.

- A Forks**
- B Frame**
- C Fork Adjustment Rods**
- D Mounting Pins**



Fig. 1 Machine Components

4.3 MACHINE BREAK-IN

Although there are no operational restrictions on the Loader Pallet Forks when used for the first time, it is recommended that the following mechanical items be checked:

A. After Operating For 1 and 5 Hours:

1. Check all nuts, bolts and other fasteners. Tighten to their specified torque level.
2. Check that the forks are in good condition.

4.4 PRE-OPERATION CHECKLIST

Efficient and safe operation of the Loader Pallet Forks requires that each operator reads and understands the operating procedures and all related safety precautions outlined in this section. A pre-operation checklist is provided for the operator. It is important for both the personal safety and maintaining the good mechanical condition of the Loader Pallet Forks that this checklist is followed.

Before operating the machine and each time thereafter, the following areas should be checked off:

- √ Use only an Agricultural tractor of the appropriate horsepower on the machine.
- √ Check that the forks are properly attached to the bucket and loader. Be sure retainers are used on the mounting pins.
- √ Be sure extra weights are mounted on the rear of the tractor if required to balance the load.
- √ Check the forks. Be sure they are not damaged or broken and are not badly worn. Repair or replace as required.
- √ Check for entangled material. Remove this material.

4.5 MOUNTING CONFIGURATIONS



OPERATING SAFETY

1. Read Operator's Manual.
2. Lower bucket/forks to the ground, stop engine, set park brake, remove ignition key and wait for all moving parts to stop before servicing, adjusting and repairing.
3. Do not carry people in bucket or on frame.
4. Add weight to rear of frame to balance bucket load.
5. Stay away from overhead power lines. Electrocutation can occur without direct contact.
6. Widen wheels or tires to prevent tipping.
7. Use only with a unit with ROPS and a seat belt.
8. Secure load in bucket to prevent roll-back down loader arms.
9. Carry load close to the ground when moving.
10. Do not go under raised bucket. Keep others away.

Loader Pallet Forks are designed as a light to moderate duty set of forks that replaces the bucket on a loader. The forks are designed specifically for handling pallets. However the operator has the responsibility of being familiar with all operating and safety procedures and following them.

1. Review and follow the Pre-Operation Checklist.
2. Attaching to loader with pin on bucket:
 - a. Remove loader bucket.
 - b. Align the loader arms with the frame mount pins.
 - c. Mount lower pins and install their retainers.
 - d. Tilt the loader if required to align the top pin holes.
 - e. Mount the upper pins and install their retainers

Each operator should review this section of the manual at the start of the season and as often as required to be familiar with the machine. When using, follow this procedure:

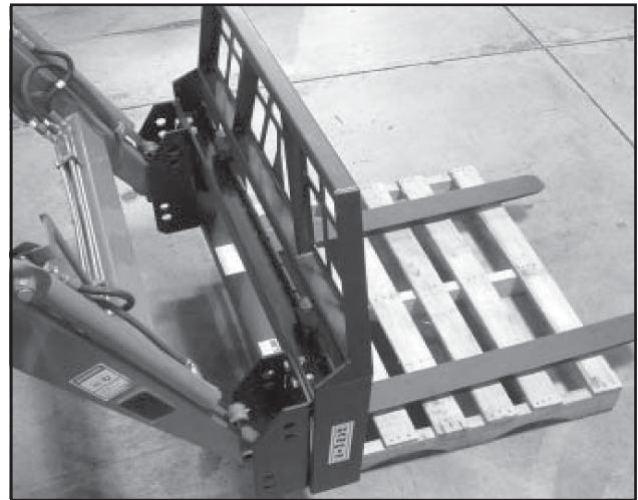

Fig. 2 Mounting with Pin System

IMPORTANT

Some loader arms are equipped with dump angle stops that extend beyond the width of the loader arms. In these cases, it may be necessary to shim the mounting pins to ensure proper clearance from the dump angle stops when operating the loader mounted fork assembly. Shimming material is available from your local dealer. Specify pin diameter and length required when ordering.

3. Mounting to select John Deere Compact and UTility loaders:
 - a. Remove loader bucket.
 - b. Align the loader's quick-change mounting system with the fork frame mount.
 - c. Drive carefully into the frame and tilt back to latch the frames together.
 - d. Attach the lynch pins and secure.



Fig. 3 Upper Pins

4. Mounting to select Skid Steer Loaders or Utility Loaders with Universal Quick Couplers.
 - a. Remove loader bucket.
 - b. Align the loader's quick-change mounting system with the fork frame mount.
 - c. Drive carefully into the frame and tilt back to latch the frames together.
 - d. Engage latch pins provided with Loader Quick-Change Coupler.

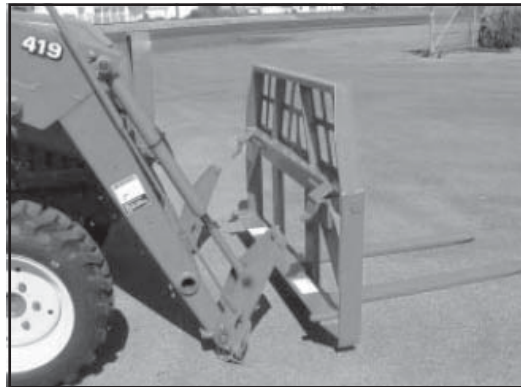

Fig. 4 Alignment

5. Before going to the working area, review Section 4.6 Transporting.
6. Drive to the working area and stop in a level area.
7. Align with the pallet and lower into working position.
8. Drive slowly into the pallet while adjusting the fork angle if required.
9. Raise the pallet.



Fig. 5 Attached

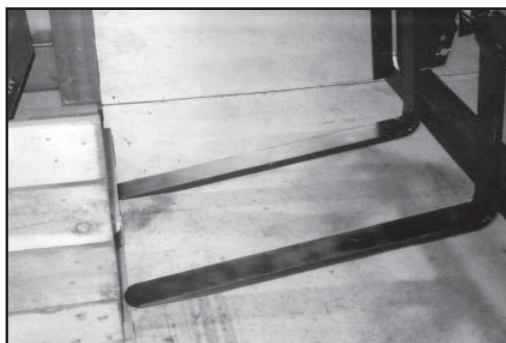

Fig. 6 Driving In

10. Operating Hints:

- a. Always center the load on the pallet between the forks to provide maximum stability.
- b. Drive into the pallet as far as you can to bring the pallet center-of-gravity as close to the tractor as possible to improve stability.
- c. Move wheels/tires to their widest position.
- d. Add ballast to the rear of the tractor to improve stability.
- e. Keep loader arms low when moving.
- f. Do not go under raised forks. Keep others away.
- g. Stay away from overhead power lines. Electrocutation can occur without direct contact.
- h. Use only with a tractor equipped with a ROPS and seat belt.
- i. Do not drive across slopes. Go straight up or down. Carry arms low.
- j. Do not carry people on forks or on frame.
- k. Use only to handle, lift or move palletized material. Do not use with loose or movable loads.



Fig. 7 Raising

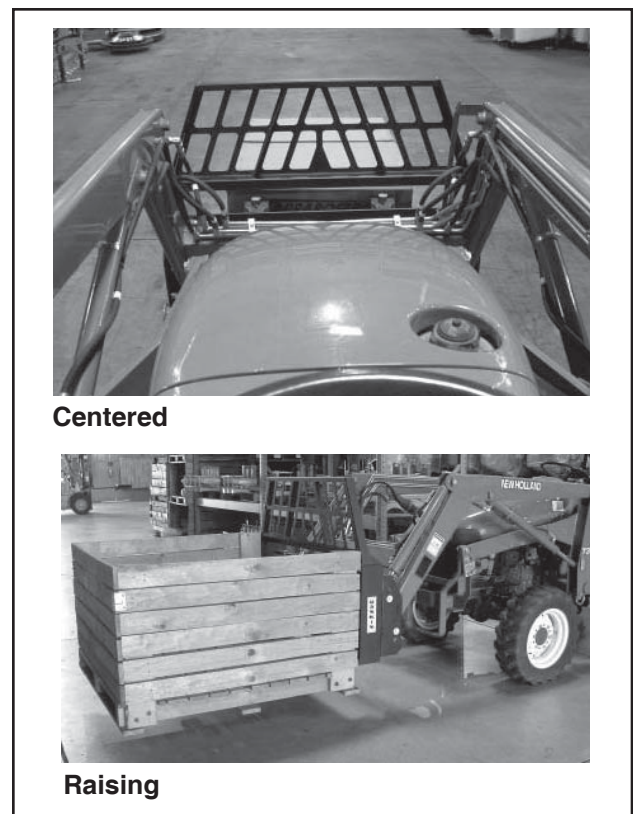

Fig. 8 Working



4.6 TRANSPORTING



TRANSPORT SAFETY

1. Make sure you are in compliance with all local regulations regarding transporting equipment on public roads and highways including lights, reflectors and the SMV.
2. Carry forks low when moving or transporting.
3. Do not allow anyone to ride on the Forks or tractor during transport.
4. Do not exceed 20 mph (32 kph). Reduce speed on rough roads and surfaces.
5. Tighten clamping hardware to its specified torque.
6. Always use hazard flashers on the tractor when transporting unless prohibited by law.

When transporting the machine, review and follow these instructions:

1. Be sure all bystanders are clear of the machine.
2. Be sure that the machine is securely attached to the tractor and all retainer pins are installed.
3. Be sure you have installed extra weights on the rear of the tractor if required.
4. Clean the SMV emblem, lights and reflectors and be sure they are working. Comply with all local regulations.
5. Carry forks low when moving or transporting.
6. Stay away from overhead power lines. Electrocutation can occur without direct contact.
7. Be sure your machine can clearly be seen by overtaking and oncoming traffic.
8. Do not allow riders.
9. Always use hazard flashers on the tractor when transporting unless prohibited by law.

4.7 STORAGE



STORAGE SAFETY

1. Store the unit in an area away from human activity.
2. Do not permit children to play on or around the stored machine.
3. Store the unit in a dry, level area. Support the frame with planks if required.

After the season's use, the machine should be thoroughly inspected and prepared for storage. Repair or replace any worn or damaged components to prevent any unnecessary down time at the start of next season. To insure a long, trouble free life, this procedure should be followed when preparing the unit for storage:

1. Clear the area of bystanders, especially small children.
2. Thoroughly wash the machine using a pressure washer to remove all dirt, mud, debris and residue.
3. Inspect the forks and frame for damage or entangled material. Repair or replace damaged parts. Remove all entangled material.
4. Touch up all paint nicks and scratches to prevent rusting.
5. Move to storage area.
6. Select an area that is dry, level and free of debris.
7. Unhook from tractor.
8. If the machine cannot be placed inside, cover with a waterproof tarpaulin and tie securely in place.
9. Store the machine in an area away from human activity.
10. Do not allow children to play on or around the stored machine.

5 TROUBLE SHOOTING

Loader Pallet Forks consist of a set of forks that mount on a loader in place of the bucket for handling pallets and palleted materials. It is a simple and reliable system that requires minimal maintenance.

In the following section we have listed many of the problems, causes and solutions to the problems that you may encounter.

If you encounter a problem that is difficult to solve, even after having read through this trouble shooting section, please call your local dealer or distributor. Before you call, please have this Operator's Manual and the serial number from your Loader Pallet Forks ready.

PROBLEM

CAUSE

SOLUTION

Cannot lift pallet.

Insufficient lift capacity.

Reduce load on pallet.

Use larger capacity loader.

6 ASSEMBLY

The machine is shipped from the factory in a partially disassembled form that allows for easy and convenient shipping.

When preparing for the customer, follow this procedure:

1. Clear the area of bystanders, especially small children.
2. Use 2 men to guide or direct and handle the heavy and bulky components.
3. Use a crane, hoist or forklift of sufficient capacity and stability to handle the components.
4. Attach to the lifting device, remove tie-downs, lift from the truck and move to the assembly area. Drive slow and keep the machine close to the ground.
5. Remove tie-downs.
6. Remove pallet.

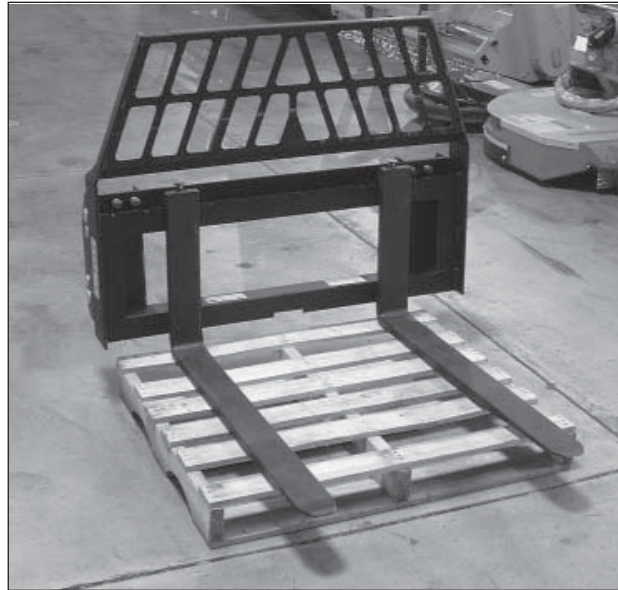

Fig. 9 Shipping Configuration

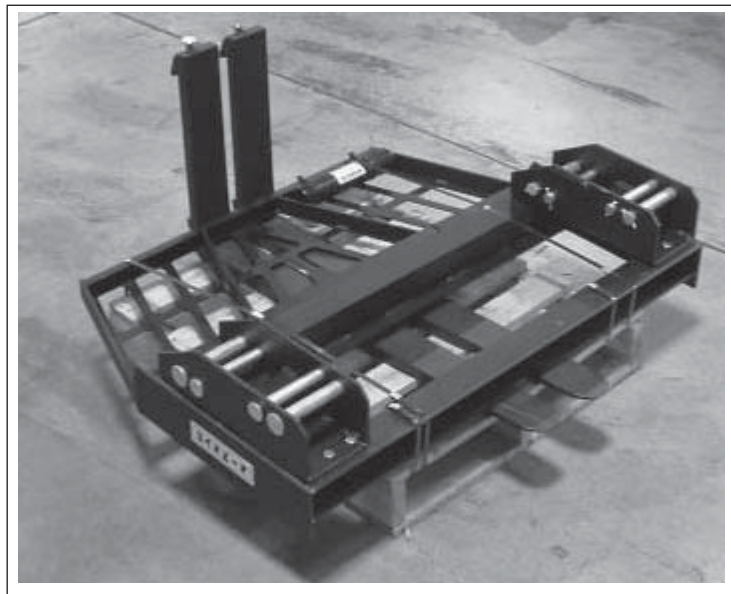

Fig. 10 Fork Assembled

7 SPECIFICATIONS

7.1 MECHANICAL

<i>SPECIFICATIONS</i>				
MODELS	ULF-3542	ULF-3548	SSF-3542	SSF-3548
LIFT CAPACITY	3500 lbs.	3500 lbs.	3500 lbs.	3500 lbs.
FORK LENGTH	42"	48"	42"	48"
TINE SIZE	1-3/8" x 4" Solid	1-3/8" x 4" Solid	1-3/8" x 4" Solid	1-3/8" x 4" Solid
ADJ. FOR FEATURES	Standard	Standard	Standard	Standard
LOADER MOUNTS	Fits many loaders frames between 32"ID and 48"OD w/ 1" or 1-1/8" pins	Fits many loaders frames between 32"ID and 48"OD w/ 1" or 1-1/8" pins	Universal Skid Steer Mount	Universal Skid Steer Mount
FORK STYLE	Rail	Rail	Rail	Rail
WEIGHT	370 lbs.	385 lbs.	375 lbs.	395 lbs.

John Deere/Kubota Forks

MODELS	JLF-3542	JLF-3548	KLF-3542	KLF-3548
LIFT CAPACITY	3500 lbs.	3500 lbs.	3500 lbs.	3500 lbs.
FORK LENGTH	42"	48"	42"	48"
TINE SIZE	1-3/8" x 4" Solid	1-3/8" x 4" Solid	1-3/8" x 4" Solid	1-3/8" x 4" Solid
ADJ. FOR FEATURES	Standard	Standard	Standard	Standard
LOADER MOUNTS	Fits John Deere Loaders w/ Quick-Change Attachment Carrier	Fits John Deere Loaders w/ Quick-Change Attachment Carrier	Fits Kubota Quick Coupler Tractor Loaders	Fits Kubota Quick Coupler Tractor Loaders
FORK STYLE	Rail	Rail	Rail	Rail
WEIGHT	380 lbs.	400 lbs.	380 lbs.	400 lbs.

7.2 BOLT TORQUE

CHECKING BOLT TORQUE

The tables shown below give correct torque values for various bolts and capscrews. Tighten all bolts to the torques specified in chart unless otherwise noted. Check tightness of bolts periodically, using bolt torque chart as a guide. Replace hardware with the same strength bolt.

ENGLISH TORQUE SPECIFICATIONS

Bolt Diameter "A"	Bolt Torque *					
	SAE 2		SAE 5		SAE 8	
	N.m	(lb-ft)	N.m	(lb-ft)	N.m	(lb-ft)
1/4"	8	(6)	12	(9)	17	(12)
5/16"	13	(10)	25	(19)	36	(27)
3/8"	27	(20)	45	(33)	63	(45)
7/16"	41	(30)	72	(53)	100	(75)
1/2"	61	(45)	110	(80)	155	(115)
9/16"	95	(70)	155	(115)	220	(165)
5/8"	128	(95)	215	(160)	305	(220)
3/4"	225	(165)	390	(290)	540	(400)
7/8"	230	(170)	570	(420)	880	(650)
1"	345	(225)	850	(630)	1320	(970)

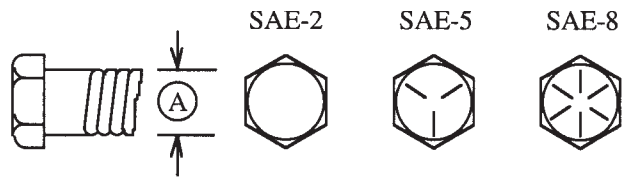

Torque figures indicated above are valid for non-greased or non-oiled threads and heads unless otherwise specified. Therefore, do not grease or oil bolts or capscrews unless otherwise specified in this manual. When using locking elements, increase torque values by 5%.

* Torque value for bolts and capscrews are identified by their head markings.

8 PARTS DIAGRAMS

8.1 ULF-3542 (3548) PALLET FORK ASSEMBLY

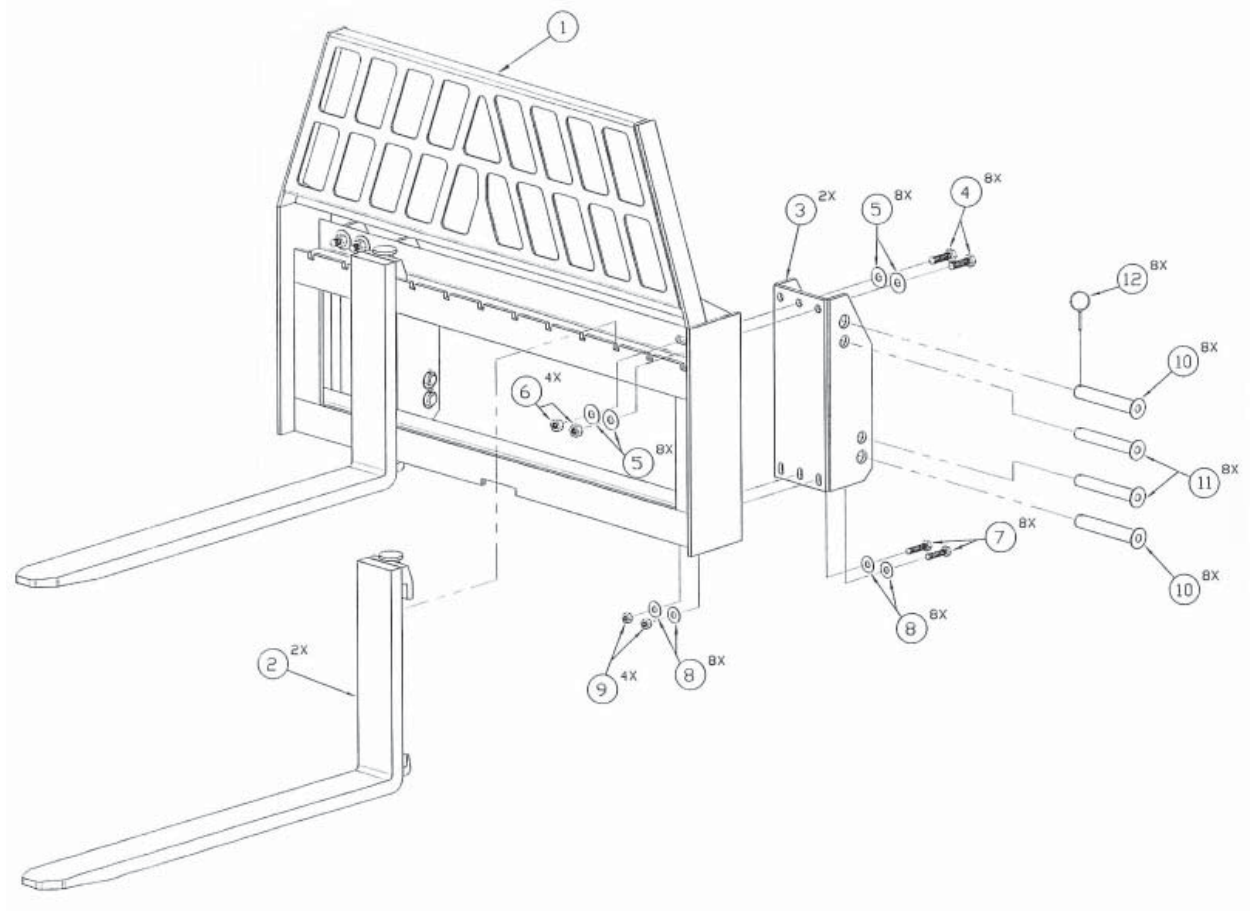

<u>REF.</u>	<u>QTY.</u>	<u>PART NO.</u>	<u>DESCRIPTION</u>
1	1	ULF-3500	Frame Assembly
2	2	41887/1065	ITA CL 2 Standard 42" Fork
2	2	41887/1020	ITA CL 2 Standard 48" Fork (not shown)
3	2	ULF-3505	Mounting Bracket
4	4	Obtain Locally	5/8" x 2" USS Grade 8 Cap Screw
5	8	Obtain Locally	5/8" USS Flat Washer
6	4	Obtain Locally	5/8" USS Nylock Nut
7	4	Obtain Locally	1/2" x 2" USS Grade 8 Cap Screw
8	8	Obtain Locally	1/2" USS Flat Washer
9	4	Obtain Locally	1/2" USS Nylock Nut
10	4	FLA-2007	1 1/8" Pin
11	4	FLA-2006	1" Pin
12	8	Obtain Locally	3/16" Lynch Pin
	1	ULF-3500 DEC	ULF-3500 Model Decal (not shown)
	1	CAUT-002	Caution Decal (not shown)
	1	DANG-001	Danger Decal (not shown)

8.2 JLF-3542 (3548) PALLET FORK ASSEMBLY

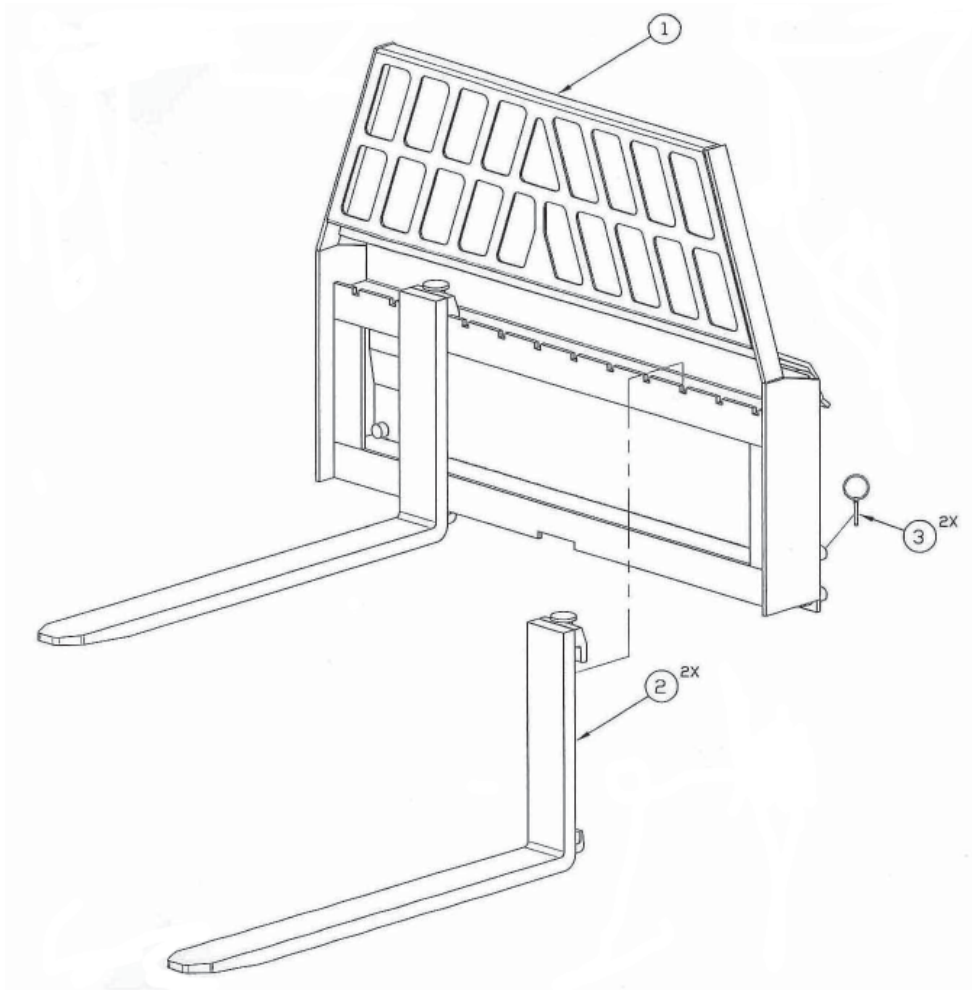

<u>REF.</u>	<u>QTY.</u>	<u>PART NO.</u>	<u>DESCRIPTION</u>
1	1	JLF-3500	Frame Assembly
2	2	41887/1065	ITA CL 2 Standard 42" Fork
2	2	41887/1020	ITA CL 2 Standard 48" Fork (not shown)
3	2	Obtain Locally	$\frac{7}{16}$ " Lynch Pin
	1	JLF-3500 DEC	JLF-3500 Model Decal (not shown)
	1	CAUT-002	Caution Decal (not shown)
	1	DANG-001	Danger Decal (not shown)

8.3 KLF-3542 (3548) PALLET FORK ASSEMBLY

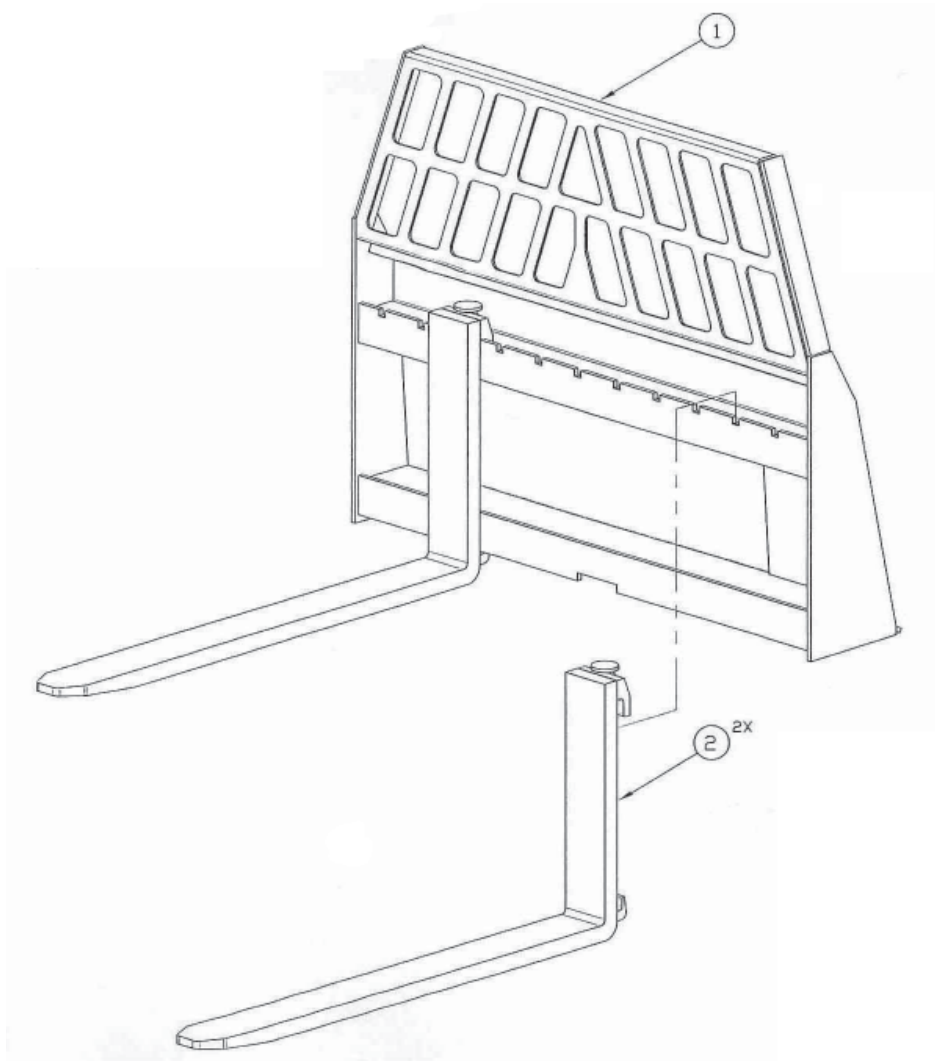

<u>REF.</u>	<u>QTY.</u>	<u>PART NO.</u>	<u>DESCRIPTION</u>
1	1	KLF-3500	Frame Assembly
2	2	41887/1065	ITA CL 2 Standard 42" Fork
2	2	41887/1020	ITA CL 2 Standard 48" Fork
	1	SSF-3500 DEC	SSF-3500 Model Decal (not shown)
	1	CAUT-002	Caution Decal (not shown)
	1	DANG-001	Danger Decal (not shown)

8.4 SSF-3542 (3548) PALLET FORK ASSEMBLY

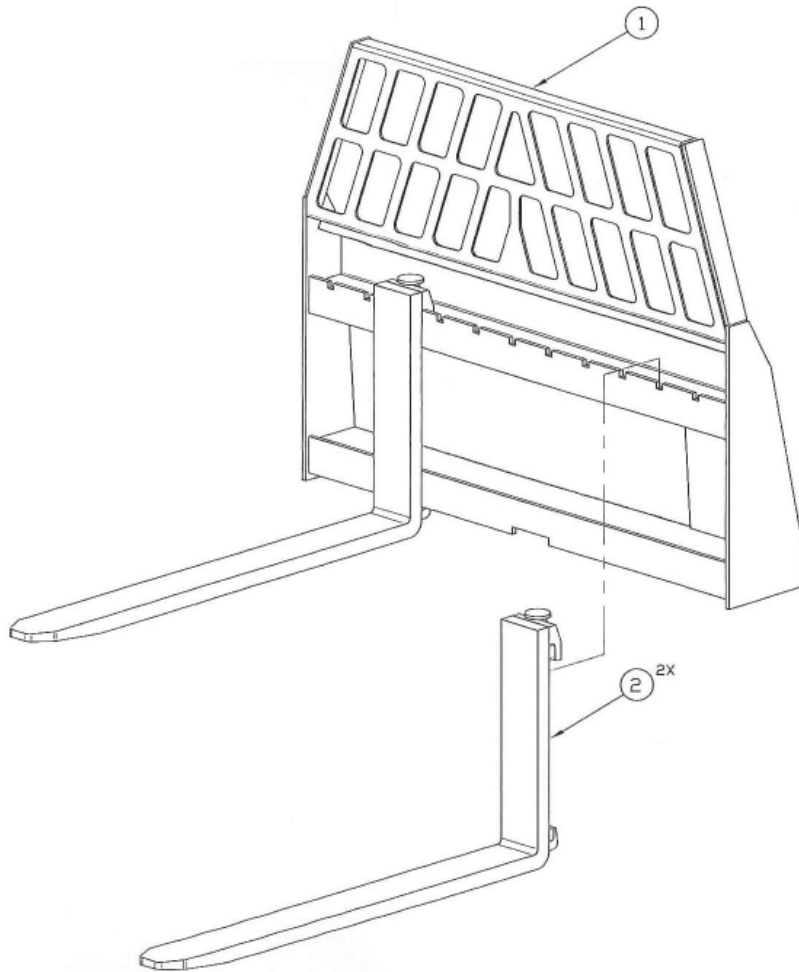

<u>REF.</u>	<u>QTY.</u>	<u>PART NO.</u>	<u>DESCRIPTION</u>
1	1	SSF-3500	Frame Assembly
2	2	41887/1065	ITA CL 2 Standard 42" Fork
2	2	41887/1020	ITA CL 2 Standard 48" Fork (not shown)
	1	SSF-3500 DEC	SSF-3500 Model Decal (not shown)
	1	CAUT-002	Caution Decal (not shown)
	1	DANG-001	Danger Decal (not shown)

9 LIMITED WARRANTY



GEARMORE, INC., warrants each new Gearmore product to be free from defects in material and workmanship for a period of twelve (12) months from date of purchase to the original purchaser. This warranty shall not apply to implements or parts that have been subject to misuse, negligence, accident, or that have been altered in any way.

Our obligation shall be limited to repairing or replacement of any part, provided that such part is returned within thirty (30) days from date of failure to Gearmore through the dealer from whom the purchase was made, transportation charges prepaid.

This warranty shall not be interpreted to render us liable for injury or damages of any kind or nature, direct, consequential or contingent, to person or property. This warranty does not extend to loss of crops, loss because of delay in harvesting or any other expenses, for any other reasons.

Gearmore in no way warrants engines, tires, or other trade accessories, since these items are warranted separately by these respective manufacturers.

Gearmore reserves the right to make improvements in design or changes in specification at any time, without incurring any obligations to owners or units previously sold.

GEARMORE, INC.
13477 Benson Ave.
Chino, CA 91710

Always refer to and heed machine operating warning decals on machine.

The serial number of this product is stored in our computer database, thus submitting a warranty registration card is not required.