



# **VENTURI AIR SPRAYERS**

**Assembly & Operation  
Manual For  
Trailer Models**

**July 2009**

# TABLE OF CONTENTS

Introduction .....	1
Assembly & Operation .....	2
Operation Of Ball Valve .....	3-6
Modular System .....	7
General Maintenance/Cleaning & Storage .....	8
Important Notices .....	9
Lifting Sprayer .....	10
General Safety Information .....	11
Safety Decals .....	12
Lubrication & Maintenance .....	13-14
Fan Support Oil Level Check .....	15
Limited Warranty .....	16

Date of Purchase:\_\_\_\_\_

Model Number:\_\_\_\_\_

Serial Number:\_\_\_\_\_

# INTRODUCTION

We welcome you as an owner of the Gearmore Venturi Air Sprayer. This sprayer has the latest technical features and benefits that today's market demands. Yet, the sprayer is quite simple to use and maintain. Before you read on to the operation and maintenance of the sprayer, please read the following general information.

**POWER SOURCE:** The sprayer is designed to mount to any 540 RPM tractor with the correct PTO horsepower.

**PUMP:** The pump on the sprayer is a low pressure centrifugal type. There is one very important point to remember with centrifugal pumps; the pump uses the liquid to cool itself. Thus, if you run the pump dry, it will be damaged quickly.

**TANK:** The tank is thick walled polyethylene, which is corrosion resistant to most chemicals.

**BLOWER:** Air is supplied by a centrifugal fan. The fan is made of steel and is precision balanced for smooth operation. A special overrunning clutch is mounted on the blower assembly to prevent damage.

**CLUTCH:** A special overrunning clutch is standard equipment. This clutch will prevent damage to the sprayer and tractor when the PTO is disengaged.

## **AGITATION:**

1. The 200 gallon sprayer is equipped with a dual agitation system, a liquid system that uses by-pass liquid from the pump and an air system that uses air from the fan housing.
2. The 300 gallon sprayers are equipped with a dual agitation system, a liquid sparging tube with a 37 GPM centrifugal pump, and an air tube system that uses air bypass from the fan housing.
3. The 500 gallon sprayers are equipped with a dual agitation system, a mechanical liquid sparging tube system run off a 37 GPM centrifugal pump, and an air tube system that uses air bypass from the fan housing.

# ASSEMBLY & OPERATION

Assembly the sprayer in the following manner:

1. Install the adjustable tongue assembly. Mount in the high or low position, depending on your tractor hitch height. Adjust in and out position of tongue, making sure that the PTO shafts are engaged as much as possible.
2. Mount wheels and tires to the stub axles.
3. Mount tire and axle to main frame. Note: Due to the offset in the axle, you can choose from 3 different height settings.
4. Install the distribution head on the sprayer using the clamps that are provided. Connect the hoses and the Dial-A-Rate metering system.
5. Mount the rear bumper.

## HOW TO OPERATE THE SPRAYER

1. Connect the sprayer to the tractor drawbar.
2. Connect the PTO driveshaft with the constant velocity end onto the tractor side, make sure the driveshaft is not too long. Be sure to attach the PTO safety shield chains.
3. Check the main filter strainer to make sure it is clean. Before cleaning the main filter, make sure the liquid level in the tank is below the filter. When reassembling the filter strainer, make sure the large o-ring is seated properly.
4. Refer to the calibration chart to set the correct rate for your application. Then set the "Dial-A-Rate" to correspond to the gallons per acre you require. On your Gearmore Venturi Air Sprayer you will have a pressure control valve which regulates the amount of pressure from 15 to 40 PSI.
5. Put water in tank.
6. Engage tractor PTO at idle speed and run for a couple of minutes to make sure the chemicals are mixed thoroughly. Engage transmission and bring engine speed up to PTO speed of at least 540 R.P.M. when spraying.
7. Turn on the electric liquid control valves. These valves can control right, left or both sides spraying, depending on what style of spray head you have mounted.

*Remember, it is always best to make a practice run with just water to be sure you have correct rates and coverage.*

# OPERATION OF BALL VALVES

For T45N1-800 - s/n 090000 & up

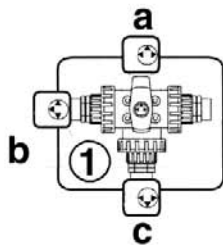
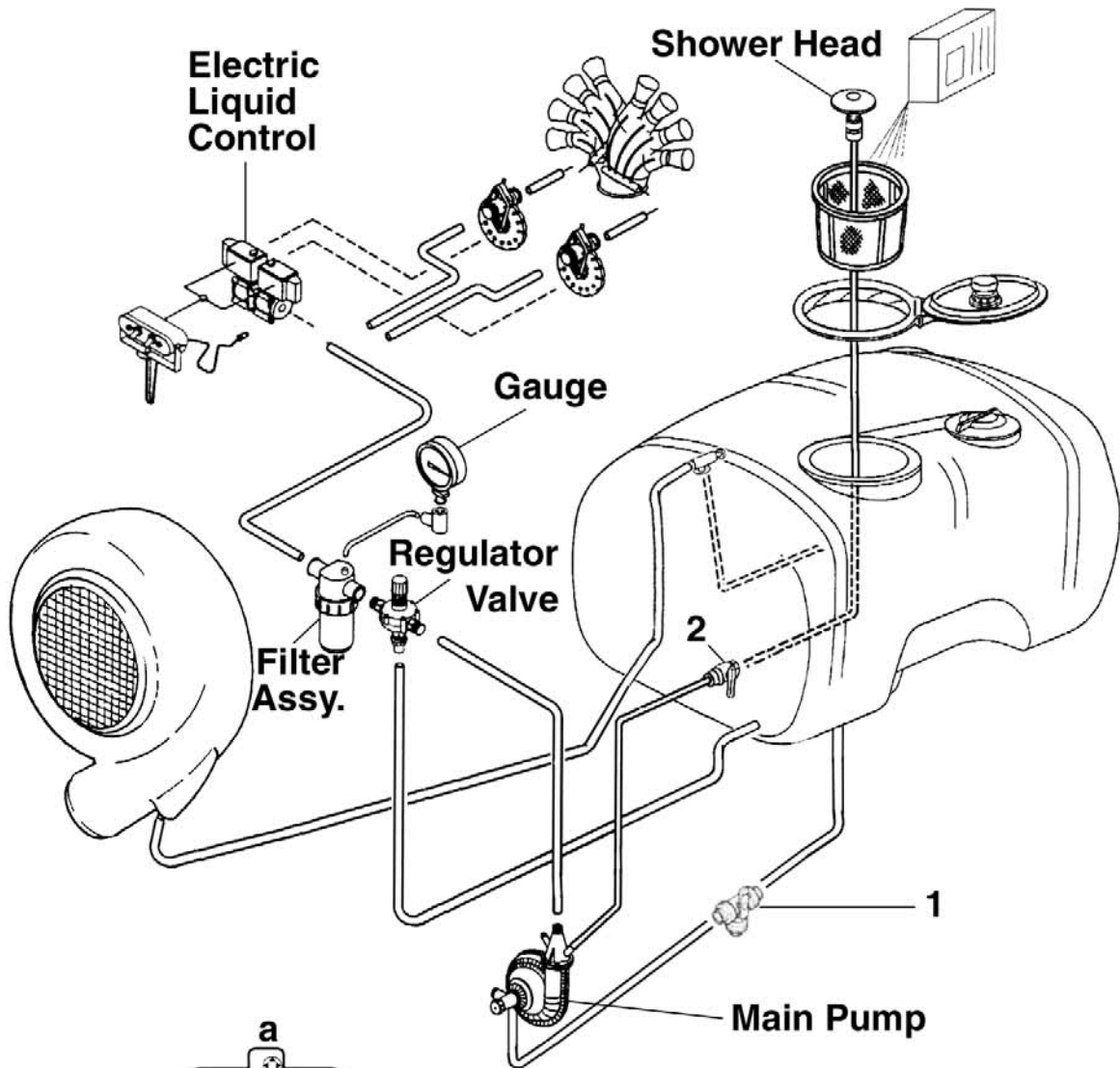

- A. Spraying Position
- B. Pump Filter Servicing
- C. Drain Position

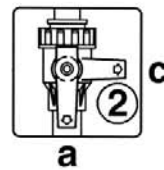

- A. Shower Head Open
- C. Spraying Position

# OPERATION OF BALL VALVES

For T45N1-800 - s/n 090000 & up

1. **THREE WAY BALL VALVE** - Mounted on front left inside frame

**Position A - Spraying**

The handle must be pointed up

**Position B - For Servicing Pump/Filter Assembly**

The handle must point towards the left port of valve. In this position liquid flow path is shut off to pump allowing pump or filter to be serviced. *Do not run sprayer in this position.*

**Position C - Spraying or Draining**

The handle must be pointed down. In this position, liquid flow path is open to pump for spraying or draining out bottom of ball valve.

2. **TWO WAY VALVE** - Mounted to the front of tank

**Position A - Shower Head Open**

In this position, liquid is sent to the shower head.

*NOTE: NEVER SPRAY WITH THIS VALVE OPEN*

**Position C - Spraying**

The handle must point sideways at all times when not using shower head.

# OPERATION OF BALL VALVES

For T50S2-1200, T55S2-1200 & T55S2-2000 - s/n 090000 & up

**LEGEND:**

- E9:** Electric Liquid Control
- E10:** Control Box
- P3:** Agitation Pump
- P4:** Main Pump
- P5:** Regulator Valve
- P7:** Filter Assembly
- P8:** Gauge
- P21:** Check Valve

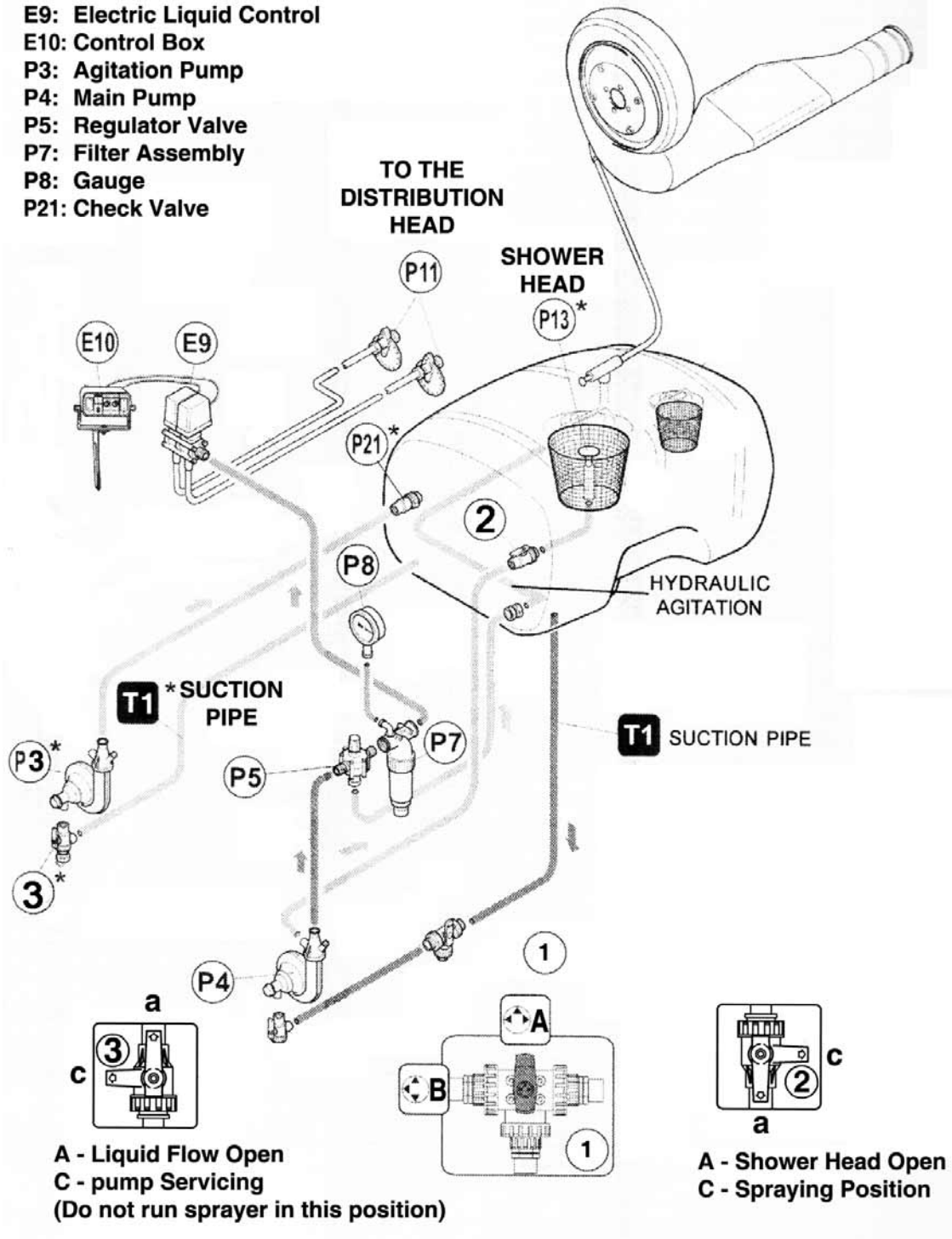

# OPERATION OF BALL VALVES

For T50S2-1200, T55S2-1200 & T55S2-2000 - s/n 090000 & up

1. **THREE WAY BALL VALVE** - Mounted on left inside frame

**Position A - Spraying**

The handle must be pointed up. (**GEARMORE RECOMMENDS LEAVING IN POSITION "A" AT ALL TIMES**)

**Position B - For Servicing Pump/Filter Assembly**

The handle must point towards the left port of valve. In this position liquid flow path is shut off to pump allowing pump to be serviced. **DO NOT RUN SPRAYER IN THIS POSITION.**

**Position C - Spraying or Draining**

The handle must point down. In this position, liquid flow path is open to pump for spraying or draining out bottom of ball valve.

2. **TWO WAY VALVE** - Mounted to the front of tank

**Position A - Shower Head Open**

In this position, liquid is sent to the shower head.

*NOTE: NEVER SPRAY WITH THIS VALVE OPEN*

**Position C - Spraying**

The handle must point sideways at all times when not using shower head.

3. **TWO WAY VALVE** - Located on bottom of agitation pump (P3)

**Position A - Liquid Flow Open**

This position allows liquid to flow to agitation pump.

**Position C - Liquid Flow Closed**

This position allows no liquid to agitation pump. **NOTE: NEVER SPRAY WITH THIS VALVE CLOSED**



# MODULAR SYSTEM

SWITCH BOX PART # 21.030.300



Connect the red cable to a 12V positive supply, with a minimum capacity of 8 amps, possibly from the ignition switch. Connect the black cable to ground, making sure of a clean connection point and that this point connects with the battery - minus.

Always use screw connections and proper terminal ends for wiring, making sure to insulate any bare connections. Protect connections with junction boxes and cable holders. Ensure wiring will not be trapped or rubbed with vibration. Check fuse rating and location according to diagram.

# GENERAL MAINTENANCE

Carefully follow all instructions as stated in this operator's manual. This includes lubrication, maintenance and operation of the sprayer. The sprayer was designed and built for years of reliable service if properly cared for. However, this sprayer is a high R.P.M. machine, thus attention is required.

- ☑ Check all bolts for tightness.
- ☑ Check sprayer for leaks.
- ☑ Check main fan power belt.
- ☑ Check pump drive belt.
- ☑ Check to make sure no foreign objects are in or near the power system.

## CLEANING & STORAGE

1. Wash and flush out sprayer after completion of each phase of your spraying program.
2. Flush out sprayer when changing chemicals if there is a possibility of incompatibility.
3. Clean sprayer very thoroughly before storing at the end of the spraying season. If you are in a cold climate, final rinse should be with a sufficiently concentrated anti-freeze to prevent freeze-up in areas that were not thoroughly drained.
4. Check sprayer over for needed repairs before time to spray again.
5. Preparing the sprayer for use in the Spring means completion of all needed repairs, installation of all drain plugs and checking sprayer for leaks with a tank of water.

## SAFETY TIPS

- ⇒ Sprayer should be operated only by qualified persons.
- ⇒ *Always* fill sprayer slowly to avoid spillage.
- ⇒ When starting sprayer, maintain a safe distance from all moving parts.
- ⇒ *Never* run P.T.O. at speeds in excess of 540 R.P.M.
- ⇒ *Do not* make adjustments when sprayer is running, unless specifically recommended.
- ⇒ *Never* leave sprayer unattended while it is running.
- ⇒ Keep hands, feet and clothing away from all moving parts.
- ⇒ Handle chemicals carefully; follow the manufacturer's directions for mixing and applying chemicals.

# IMPORTANT NOTICES

To obtain effective spray atomization and chemical agitation, you must operate your tractor at recommended maximum engine R.P.M. to obtain correct P.T.O. speed of 540 R.P.M.

**DO NOT ALLOW POWDER CHEMICALS TO STAY IN THE TANK WITHOUT AGITATION**

Powder chemicals that do not dissolve will settle to the bottom of the tank when the agitation is stopped and may damage the pump when it is started.

**AFTER EACH USE, BEFORE STORING THE SPRAYER**

1. Be sure to drain and clean out the tank.
2. Run clean water through the entire system.
3. Remove the cap on the front of the pump.
4. Remove and clean the main filter.

# LIFTING SPRAYER

When lifting or transporting the sprayer, the following actions are not allowed:



- Transporting or lifting the sprayer with residual quantities of mixture in the tank for purposes differing from its destined usage.
- Transporting of people, animals or things.
- Trailing of vehicles or equipment.

Road transport must take place in the complete observance of road regulations in force in the city where the machine is used. The operator is responsible for possible defaults due to the non observance of said regulations.

## LIFTING AND TRANSPORT OF THE SPRAYER

Before carrying out any operation it is essential to verify that no mixture residues are left in the tank.

1. Check that the lifting devices (bands, ropes, etc.) are adequate for the weight to be lifted (machine - distribution devices - accessories).
2. Hook the machine through the specific support points indicated by the decals on the frame, checking all the parts involved in the operation.
3. Lift the machine, verifying that it is properly balanced.

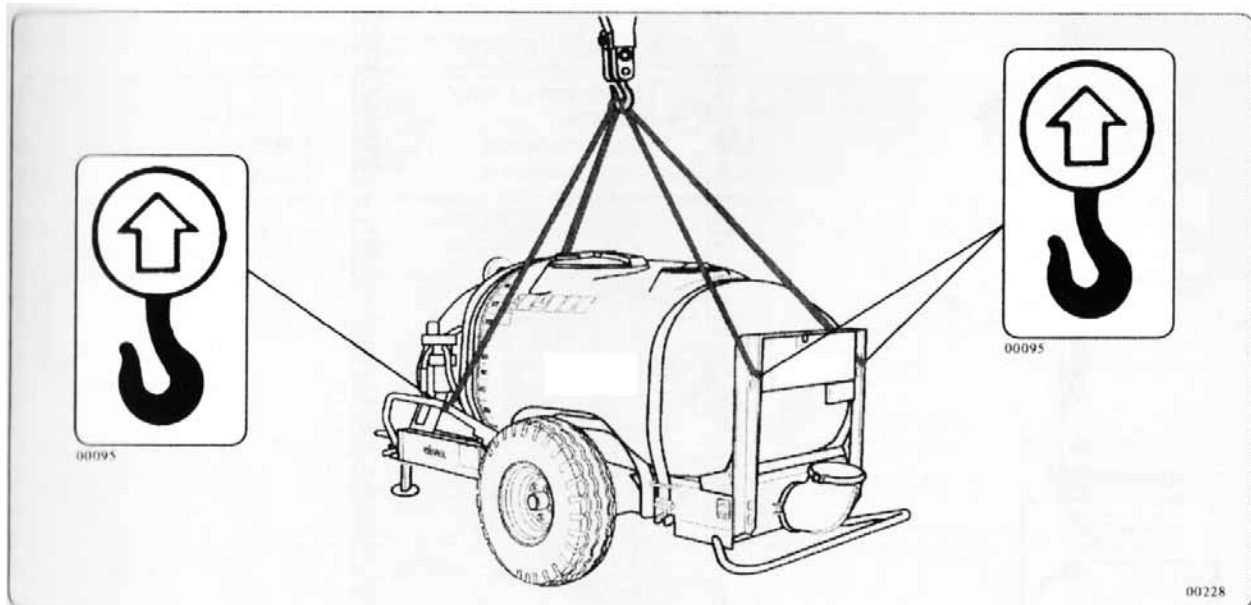

4. Position the sprayer on the transporting vehicle in perfectly stable conditions.
5. Lock the sprayer with the wedges locking wheel.
6. During transport the machine must be immobilized and fastened to the carrier by way of suitable strapping.

# GENERAL SAFETY INFORMATION

## DO NOT OPERATE PUMP WITHOUT LIQUID IN TANK



**WARNING:** Do not pump flammable or explosive fluids such as gasoline, fuel oil, kerosene, etc. Do not use in explosive atmospheres. The pump should be used only with liquids compatible with the pump component materials. Failure to follow this warning may result in personal injury and/or property damage and will void the product warranty.

- ▶ **Do not** operate pump above recommended R.P.M.
- ▶ Operate pump between 45°F and 145°F liquid temperatures.
- ▶ Make certain that the power source conforms to the requirements of your equipment.
- ▶ Provide adequate protection in guarding around the moving parts such as the shaft and pulleys.
- ▶ Disconnect power before servicing.
- ▶ Release all pressure within the system before servicing any component.
- ▶ Drain all liquids from the system before servicing.
- ▶ Secure the discharge lines before starting the pump. An unsecured discharge line may whip, causing personal injury and/or property damage.
- ▶ Check hoses for weak or worn conditions before each use. Make certain that all connections are tight and secure.
- ▶ Periodically inspect the pump and the system components. Perform routine maintenance as required (see *Maintenance Section*).
- ▶ **Do not** use these pumps for pumping water or other liquids for human or animal consumption.

# SAFETY DECALS

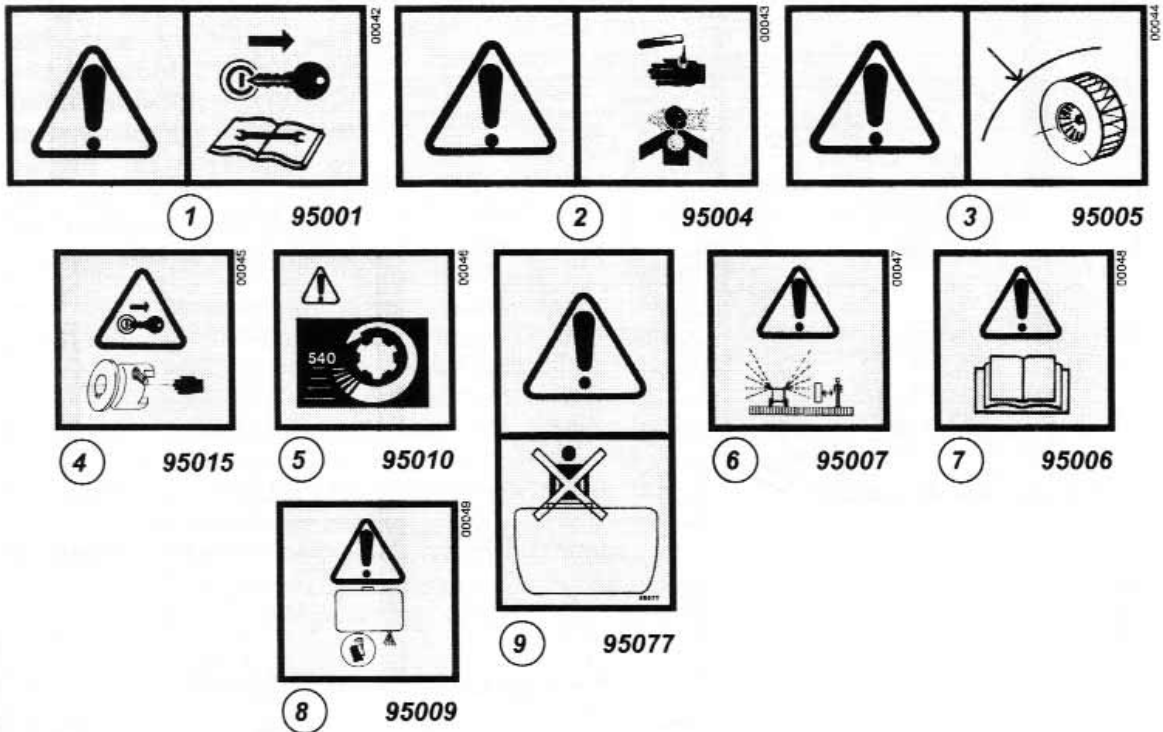

## \* Use and maintenance decals

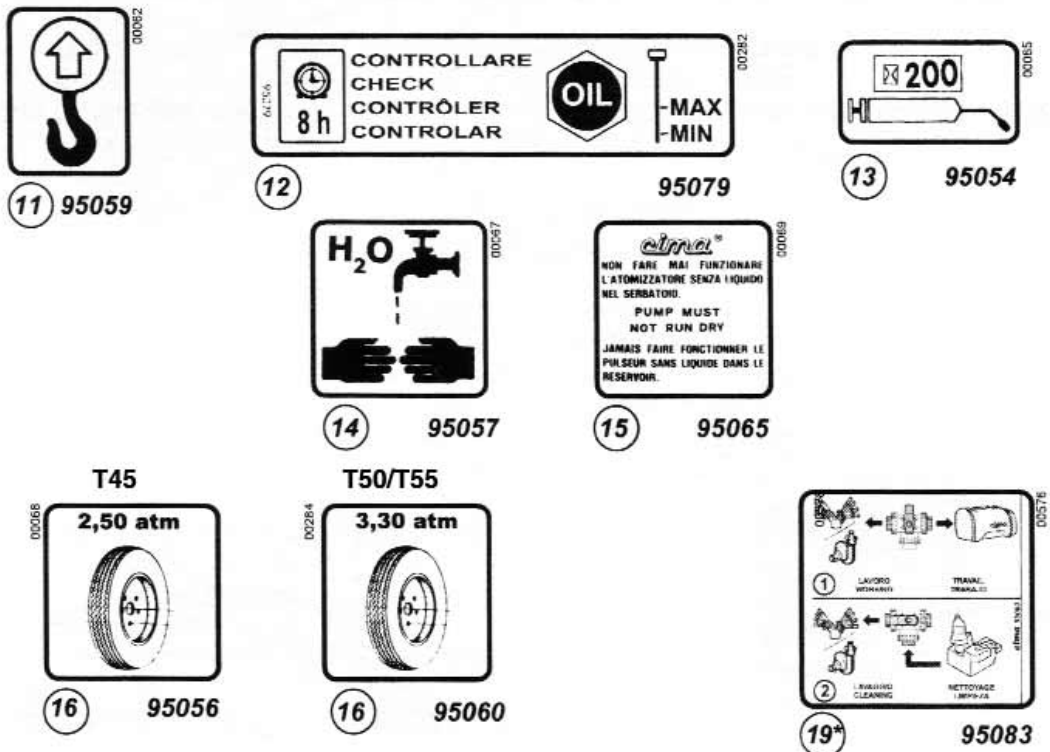

# LUBRICATION & MAINTENANCE

## For all trailer sprayers with s/n starting at 040000---

1. Located on the back side of the pump is a oil reservoir. Using an oil can, add approximately 10 drops of SAE 15W40 engine oil **every 50 hours** of use. (Ref. 1)
2. The oil filler for the fan support bearings is located behind the fan housing and in front of the main frame by the fan housing. Check the oil **every 8 hours** of use. The oil needs to be changed **yearly**. (See page 15 for additional information)
3. The main drive belt idler assembly has sealed bearings, but the idler needs to be greased **every 200 hours** to allow it to pivot freely. This grease zerk is located on the right side main frame by the fan housing. (Ref. 3)
4. The overrunning clutch is designed to allow the fan assembly to rotate freely when the tractor PTO is shut down. This grease zerk is located behind the PTO driveline and requires you to remove the PTO to lubricate. Grease this zerk **every 200 hours** of use. (Ref. 4)
5. The axle wheel bearings should be greased **every 200 hours**. (Ref. 5)
6. The front tongue assembly should be greased **every 200 hours**. (Ref. 6)
7. The support stand should be greased **every 200 hours**. (Ref. 7)
8. The PTO driveshaft u-joints should be greased every 8 hours and the shafts **every 20 hours**. The PTO safety shields have a plastic zerk for the shield bearings that should also be greased **every 20 hours**.

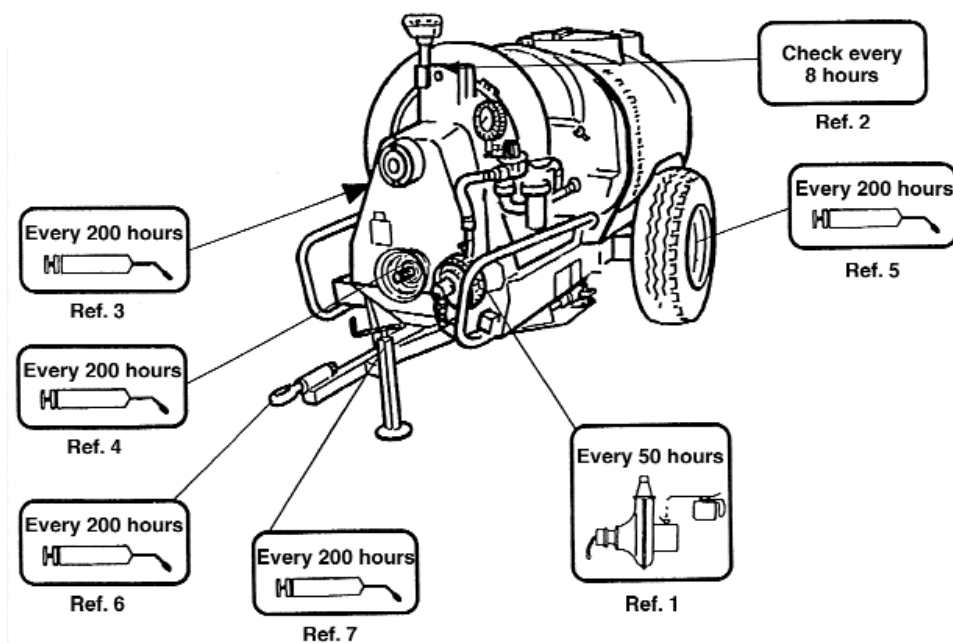



# LUBRICATION & MAINTENANCE

## LUBRICATION OF THE DRIVESHAFT:

Grease crosses (A) **weekly**. Grease shafts (B) **monthly**.



## MAIN STRAINER:

Clean strainer screen before each treatment and when required.

To clean screen, it is necessary to make sure the tank liquid level is below the filter assembly.

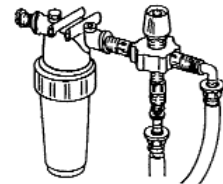

## BELT TENSION:

At the beginning of the season check that the spring length is within specifications on both belt drives.

1. Fan Drive Belt:  $3 \frac{1}{2}'' - 4 \frac{5}{8}''$  (Ref. A)
2. Pump Drive Belt:  $1 \frac{1}{2}'' - 2''$  (Ref. B)

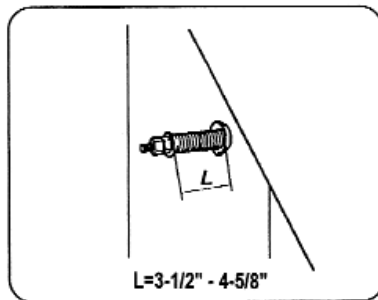

Ref. A

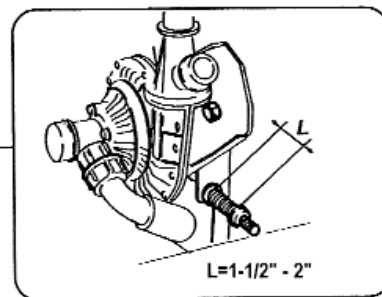
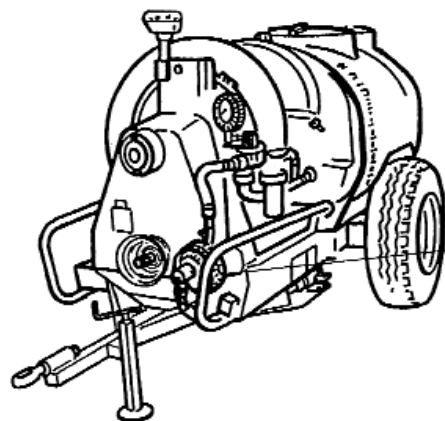
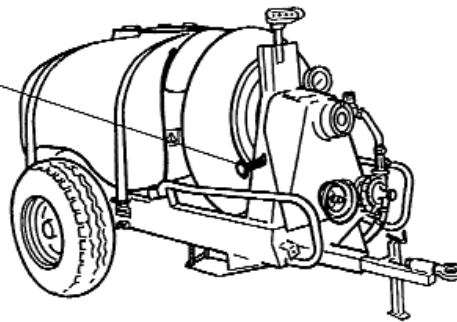

Ref. B



# FAN SUPPORT OIL LEVEL CHECK

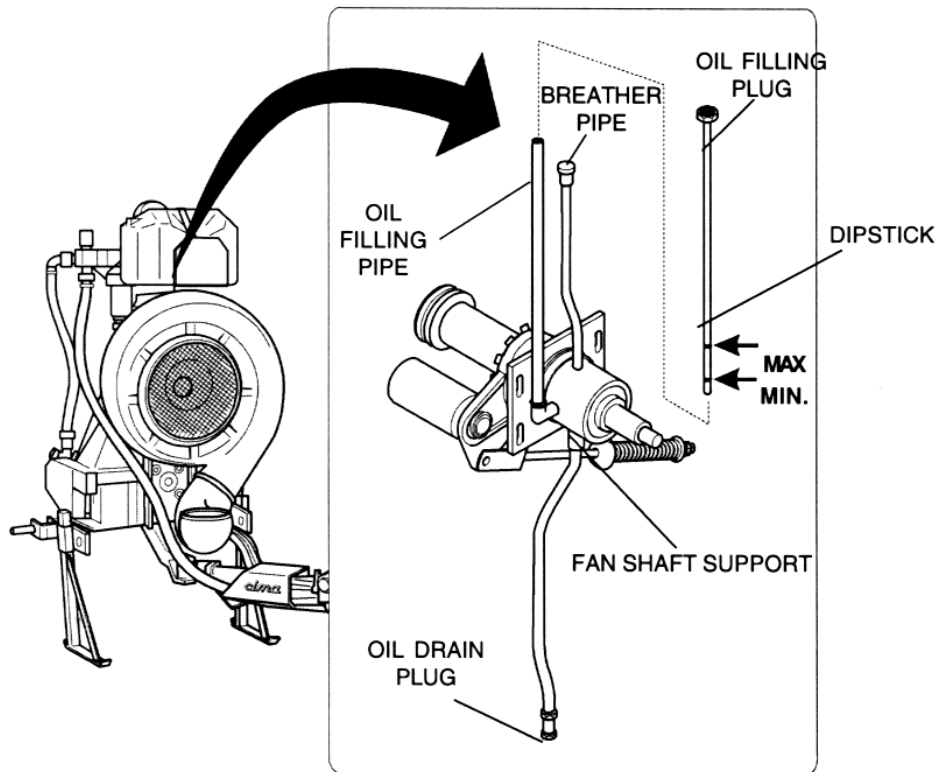

1. Unscrew and remove the oil filling plug with dipstick.
2. Clean the dipstick and reinsert in oil tube.
3. Remove dipstick and check oil level. Oil should be between the min. and max. marking on dipstick. If oil is low add SAE 90 wt. oil.
4. Reinstall dipstick and re-tighten.

## CHANGING FAN SUPPORT OIL

1. Unscrew and remove the oil filling plug with dipstick.
2. Remove the oil drain plug and drain oil completely.
3. Replace oil drain plug.
4. Through the filling pipe, pour SAE 90 wt. oil to proper level on dipstick.
5. Reinstall dipstick and re-tighten.

# LIMITED WARRANTY



GEARMORE, INC., warrants each new Gearmore product to be free from defects in material and workmanship for a period of twelve (12) months from date of purchase to the original purchaser. This warranty shall not apply to implements or parts that have been subject to misuse, negligence, accident, or that have been altered in any way.

Our obligation shall be limited to repairing or replacement of any part, provided that such part is returned within thirty (30) days from date of failure to Gearmore through the dealer from whom the purchase was made, transportation charges prepaid.

This warranty shall not be interpreted to render us liable for injury or damages of any kind or nature, direct, consequential or contingent, to person or property. This warranty does not extend to loss of crops, loss because of delay in harvesting or any other expenses, for any other reasons.

Gearmore in no way warrants engines, tires, or other trade accessories, since these items are warranted separately by these respective manufacturers.

Gearmore reserves the right to make improvements in design or changes in specification at any time, without incurring any obligations to owners or units previously sold.

GEARMORE, INC.  
13477 Benson Ave.  
Chino, CA 91710

Always refer to and heed machine operating warning decals on machine.

*The serial number of this product is stored in our computer database, thus submitting a warranty registration card is not required.*