

GEARMORE INC.

GROUND DRIVEN SEEDER / SPREADER



**Assembly, Parts
& Operator's Manual
For Model
T202L**

August 2004

TABLE OF CONTENTS

SECTION	DESCRIPTION	PAGE
1	Introduction	1
1.1	Serial Number Location	2
2	Safety	3
2.1	General Safety	4
2.2	Equipment Safety Guidelines	5
2.3	Safety Training	6
2.4	Safety Signs	6
2.5	Preparation	7
2.6	Operating Safety	8
2.7	Transport Safety	9
2.8	Storage Safety	9
2.9	Maintenance Safety	9
3	Safety Sign Locations	10
4	Operation	11
4.1	To the New Operator or Owner	11
4.2	Machine Components	11
4.3	Assembly	12
4.4	Pre-Operation Checklist	12
4.5	Field Operation	13
4.6	Transporting	14
4.7	Storage	15
5	Service and Maintenance	15
5.1	Service	16
5.1.1	Fluids and Lubricants	16
5.1.2	Greasing	16
5.1.3	Servicing Intervals	16
5.2	Maintenance	16
5.3	Ordering Parts	16
6	Specifications	17
6.1	Mechanical	17
6.2	Bolt Torque	18
7	Parts Breakdown	19
7.1	Gearbox	19
7.2	Seeder / Spreader	20-21
8	Limited Warranty	22

1 INTRODUCTION

Congratulations on your choice of a ground driven Seeder / Spreader. This equipment has been designed and manufactured to meet the needs of a discriminating buyer for efficient spreading of seed, fertilizer, sand, and salt.

Our Seeder / Spreader is the ideal implement for use when a PTO is not available. This unit has a ground driven, cast iron, oil bath gearbox that can be disengaged when transporting. It is ideal for spreading seed, fertilizer, sand, and salt. It has 15" diameter tires that are 6" wide which makes this a "Turf Friendly" implement. This unit is a handy tool for farmers, landscapers, and ranchers.

Safe, efficient and trouble free operation of your Seeder / Spreader requires that you and anyone else who will be operating or maintaining the machine, read and understand the Safety, Operation, and Maintenance information contained within the Operator's Manual.

This manual covers the T202L Ground Driven Seeder / Spreader. Use the Table of Contents as a guide to locate required information.

Keep this manual handy for frequent reference and to pass on to new operators or owners. Call your dealer if you need assistance, information or additional copies of the manuals.

OPERATOR ORIENTATION - The directions left, right, front and rear, as mentioned throughout this manual, are as seen from the driver's seat and facing in the direction of travel.

NOTE: Gearmore reserves the right to discontinue models at any time, change specifications, and improve design without notice and without incurring obligation on goods previously purchased and to discontinue supplying any part listed, when the demand does not warrant production.

1.1 SERIAL NUMBER LOCATION

It is very important that the correct serial number is provided when ordering parts.

The serial number plate is located on the front plate at the bottom of the hopper.

Please mark the model and serial number of your attachment in the space provided below in case the plate on your attachment gets lost or damaged.

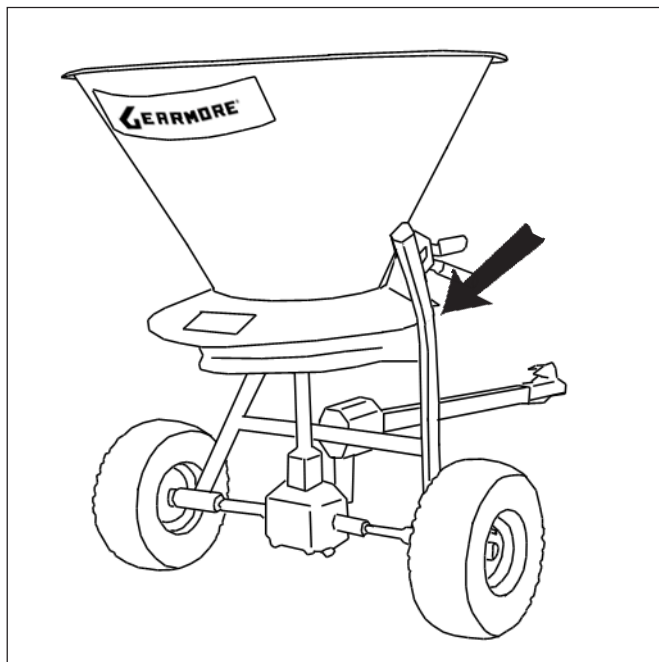

Model No: _____

Serial No: _____

Date of Purchase: _____

2 SAFETY

SAFETY ALERT SYMBOL

This Safety Alert symbol means **ATTENTION! BECOME ALERT! YOUR SAFETY IS INVOLVED!**



The Safety Alert symbol identifies important safety messages on the Gearmore Seeder/Spreader and in the manual. When you see this symbol, be alert to the possibility of personal injury or death. Follow the instructions in the safety message.

Why is SAFETY important to you?

3 Big Reasons

Accidents Disable and Kill
Accidents Cost
Accidents Can Be Avoided

SIGNAL WORDS:

Note the use of the signal words **DANGER**, **WARNING** and **CAUTION** with the safety messages. The appropriate signal word for each message has been selected using the following guide-lines:

SI NO LEE INGLES, PIDA AYUDA A AIGUIEN QUE SI LO LEA PARA QUE LE TRADUZCA LAS MIDIDAS DE SEGURIDAD.

DANGER - Indicates an imminently hazardous situation that, if not avoided, will result in death or serious injury. This signal word is to be limited to the most extreme situations typically for machine components which, for functional purposes, cannot be guarded.

WARNING - Indicates a potentially hazardous situation that, if not avoided, could result in death or serious injury, and includes hazards that are exposed when guards are removed. It may also be used to alert against unsafe practices.

CAUTION - Indicates a potentially hazardous situation that, if not avoided, may result in minor or moderate injury. It may also be used to alert against unsafe practices.

If you have any questions not answered in this manual or require additional copies or the manual is damaged, please contact your dealer.

SAFETY

YOU are responsible for the **SAFE** operation and maintenance of your Seeder/Spread. **YOU** must ensure that you and anyone else who is going to operate, maintain or work around the Seeder / Spreader be familiar with the operating and maintenance procedures and related **SAFETY** information contained in this manual. This manual will take you step-by-step through your working day and alerts you to all good safety practices that should be adhered to while operating the Seeder / Spreader.

Remember, **YOU** are the key to safety. Good safety practices not only protect you but also the people around you. Make these practices a working part of your safety program. Be certain that **EVERYONE** operating this equipment is familiar with the recommended operating and maintenance procedures and follows all the safety precautions. Most accidents can be prevented. Do not risk injury or death by ignoring good safety practices.

- Implement owners must give operating instructions to operators or employees before allowing them to operate the machine, and at least annually thereafter per OSHA (Occupational Safety and Health Administration) regulation 1928.57.
- The most important safety feature on this equipment is a **SAFE** operator. It is the operator's responsibility to read and understand **ALL** Safety and Operating instructions in the manual and to follow these. Most accidents can be avoided.
- A person who has not read and understood all operating and safety instructions is not qualified to operate the machine. An untrained operator exposes himself and bystanders to possible serious injury or death.
- Do not modify the equipment in any way. Unauthorized modification may impair the function and/or safety and could affect the life of the equipment.
- **Think SAFETY! Work SAFELY!**

2.1 GENERAL SAFETY

1. Read and understand the Operator's Manual and all safety signs before operating, maintaining, adjusting or unclogging the Seeder/Spread.



2. Have a first-aid kit available for use should the need arise and know how to use it.



3. Have a fire extinguisher available for use should the need arise and know how to use it.



4. Wear appropriate protective gear. This list includes but is not limited to:

- A hard hat
- Protective shoes with slip resistant soles
- Protective goggles, glasses or face shield
- Heavy gloves
- Protective clothing



5. Do not allow riders.
6. Wear suitable ear protection for prolonged exposure to excessive noise.



7. Place all controls in neutral, stop tractor engine, set park brake, remove ignition key and wait for all moving parts to stop before servicing, adjusting, repairing or unclogging.
8. Clear the area of people, especially small children, before starting.
9. Review safety related items annually with all personnel who will operating or maintaining the Seeder/Spread.

2.2 EQUIPMENT SAFETY GUIDELINES

1. Safety of the operator and bystanders is one of the main concerns in designing and developing a machine. However, every year many accidents occur which could have been avoided by a few seconds of thought and a more careful approach to handling equipment. You, the operator, can avoid many accidents by observing the following precautions in this section. To avoid personal injury or death, study the following precautions and insist those working with you, or for you, follow them.
2. Check all bolts for tightness and grease the machine before each use.
3. Replace any safety sign or instruction sign that is not readable or is missing. Location of such safety signs is indicated in this manual.
4. Never use alcoholic beverages or drugs which can hinder alertness or coordination while operating this equipment. Consult your doctor about operating this machine while taking prescription medications.
5. **Under no circumstances should young children be allowed to work with this equipment. Do not allow persons to operate or assemble this unit until they have read this manual and have developed a thorough understanding of the safety precautions and of how it works.** Review the safety instructions with all users annually.
6. This equipment is dangerous to children and persons unfamiliar with its operation. The operator should be a responsible, properly trained and physically able person familiar with farm machinery and trained in this equipment's operations. If the elderly are assisting with work, their physical limitations need to be recognized and accommodated.
7. Use a tractor equipped with a Roll Over Protective Structure (ROPS) and a seat belt.
8. Never exceed the limits of a piece of machinery. If its ability to do a job, or to do so safely, is in question - **DON'T TRY IT.**
9. **Do not** modify the equipment in any way. Unauthorized modification may result in serious injury or death and may impair the function and life of the equipment.
10. In addition to the design and configuration of this implement, including Safety Signs and Safety Equipment, hazard control and accident prevention are dependent upon the awareness, concern, prudence, and proper training of personnel involved in the operation, transport, maintenance, and storage of the machine. Refer also to Safety Messages and operation instruction in each of the appropriate sections of the Tractor/ATV and Machine Manuals. Pay close attention to the Safety Signs affixed to the Tractor/ATV and the machine.

2.3 SAFETY TRAINING

1. Safety is a primary concern in the design and manufacture of our products. Unfortunately, our efforts to provide safe equipment can be wiped out by a single careless act of an operator or bystander.
2. In addition to the design and configuration of equipment, hazard control and accident prevention are dependent upon the awareness, concern, prudence and proper training of personnel involved in the operation, transport, maintenance and storage of this equipment.
3. It has been said, "The best safety feature is an informed, careful operator." We ask you to be that kind of an operator. It is the operator's responsibility to read and understand ALL Safety and Operating instructions in the manual and to follow these. Accidents can be avoided.
4. **Working with unfamiliar equipment can lead to careless injuries. Read this manual, and the manual for your tractor/ATV, before assembly or operating, to acquaint yourself with the machines. If this machine is used by any person other than yourself, or is loaned or rented, it is the machine owner's responsibility to make certain that the operator, prior to operating:**
 - a. **Reads and understands the operator's manuals.**
 - b. **Is instructed in safe and proper use.**
5. Know your controls and how to stop tractor/ATV engine, and machine quickly in an emergency. Read this manual and the one provided with your tractor.
6. Train all new personnel and review instructions frequently with existing workers. Be certain only a properly trained and physically able person will operate the machinery. A person who has not read and understood all operating and safety instructions is not qualified to operate the machine. An untrained operator exposes himself and bystanders to possible serious injury or death. If the elderly are assisting with farm work, their physical limitations need to be recognized and accommodated.

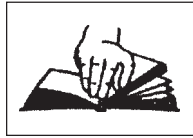

2.4 SAFETY SIGNS

1. Keep safety signs clean and legible at all times.
2. Replace safety signs that are missing or have become illegible.
3. Replaced parts that displayed a safety sign should also display the current sign.
4. Safety signs are available from your authorized Distributor or Dealer Parts Department or the factory.

How to Install Safety Signs:

- Be sure that the installation area is clean and dry.
- Be sure temperature is above 50°F (10°C).
- Determine exact position before you remove the backing paper. (See Section 3).
- Remove the smallest portion of the split backing paper.
- Align the sign over the specified area and carefully press the small portion with the exposed sticky backing in place.
- Slowly peel back the remaining paper and carefully smooth the remaining portion of the sign in place.
- Small air pockets can be pierced with a pin and smoothed out using the piece of sign backing paper.

2.5 PREPARATION

1. Never operate the tractor/ATV and machine until you have read and completely understand this manual, the Tractor/ATV Operator's Manual, and each of the Safety Messages found on the safety signs on the tractor/ATV and machine.

2. Personal protection equipment including hard hat, safety glasses, safety shoes, and gloves are recommended



during assembly, installation, operation, adjustment, maintaining, repairing, removal, or moving the implement. Do not allow long hair, loose fitting clothing or jewelry to be around equipment.

3. **PROLONGED EXPOSURE TO LOUD NOISE MAY CAUSE PERMANENT HEARING LOSS!**

Tractors/ATVs with or without equipment attached can often be noisy enough to cause permanent, partial hearing loss. We recommend that you wear hearing protection on a full-time basis if the noise in the Operator's position exceeds 80db. Noise over 85db on a long-term basis can cause severe hearing loss. Noise over 90db adjacent to the Operator over a long-term basis may cause permanent, total hearing loss. **NOTE:** Hearing loss from loud noise (from tractors, chain saws, radios, and other such sources close to the ear) is cumulative over a lifetime without hope of natural recovery.

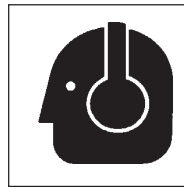

4. Operate the machine only with a tractor equipped with an approved Roll-Over-Protective Structure (ROPS). Always wear your seat belt. Serious injury or even death could result from falling off the tractor ---particularly during a turnover when the operator could be pinned under the ROPS or the tractor.



5. Operate only in daylight or good artificial light.
6. Be sure machine is properly mounted, adjusted and in good operating condition.
7. Ensure that all safety shielding and safety signs are properly installed and in good condition.
8. Never place hands or objects into the hopper with the spreader / seeder operating.

◆ **Think Safety, Work Safely!!**

2.6 OPERATING SAFETY

1. Please remember it is important that you read and heed the safety signs on the Seeder/Spreader. Clean or replace all safety signs if they cannot be clearly read and understood. They are there for your safety, as well as the safety of others. The safe use of this machine is strictly up to you, the operator.
2. All things with moving parts are potentially hazardous. There is no substitute for a cautious, safe-minded operator who recognizes potential hazards and follows reasonable safety practices.
3. Safety is our first concern at Gearmore. Safety must also be first in the mind of the operator of the Seeder/Spreader. Proper maintenance is necessary to complete the safety cycle.
4. Personal protection equipment including hard hat, safety glasses, hearing protection, safety shoes, and tight gloves are recommended during assembly, installation, operation, adjustment, maintaining, repairing, removal, or moving. Do not allow long hair, loose fitting clothing, or jewelry to be around moving parts.
5. Always use two people to handle heavy, unwieldy components during assembly, installation, removal or moving.
6. Never place any part of your body, fingers, hands, feet, etc. where it would be in danger if movement should occur during assembly, installation, operation, maintaining, repairing, removal or moving. Keep others away.
7. Never use alcoholic beverages or drugs which can hinder alertness or coordination while operating this equipment. Consult your doctor about operating this machine while taking prescription medications.
8. Do not allow riders on the machine or tractor/ATV at any time. There is no safe place for any riders.
9. Before you operate the machine, check over all pins, bolts, and connections to be sure all are securely in place and tight. Tighten or replace any damaged or worn parts immediately.
10. Do not allow anyone who is not familiar with the safety rules and operation instructions to use this machine.
11. Never allow children to operate or be around this machine.
12. Do not operate on slopes or hillsides. Sloping terrain can cause machine to roll or slip.

2.7 TRANSPORT SAFETY

1. Comply with state and local laws governing highway safety and movement of machinery on public roads.
2. The use of flashing amber lights is acceptable in most localities. However, some localities prohibit their use. Local laws should be checked for all highway lighting and marking requirements.
3. At all times, when driving the tractor and equipment on the road or highway under 20 mph (32 kph) use flashing amber warning lights and a slow moving vehicle (SMV) identification emblem. Do not exceed 20 mph (32 kph). Reduce speed on rough roads and surfaces.
4. Plan your route to avoid heavy traffic.
5. Always install transport locks, pins or brackets before transporting. For transporting it is advisable to disconnect drive thereby disengaging the spreading disc.
6. Do not drink and drive.
7. Be a safe and courteous driver. Always yield to oncoming traffic in all situations, including narrow bridges, intersections, etc. Watch for traffic when operating near or crossing roadways.
8. Turn into curves or go up or down hills only at a low speed and at a gradual steering angle. Make certain that at least 20% of the tractor's weight is on the front wheels to maintain safe steering. Slow down on rough or uneven surfaces.
9. Never allow riders on either tractor/ATV or implement.

2.8 STORAGE SAFETY

1. Store the unit in an area away from human activity.
2. Do not permit children to play on or around the stored machine.
3. Store the unit in a dry, level area. Support the implement with planks if required.

2.9 MAINTENANCE SAFETY

1. Good maintenance is your responsibility. Poor maintenance is an invitation to trouble.
2. Follow good shop practices.
 - Keep service area clean and dry.
 - Be sure electrical outlets and tools are properly grounded.
 - Use adequate light for the job at hand.
3. Make sure there is plenty of ventilation. Never operate the engine of the tractor/ATV in a closed building. The exhaust fumes may cause asphyxiation.
4. Before working on this machine, shut off the engine, set the brakes, and remove the ignition keys.
6. Never work under equipment unless it is blocked securely.
7. Use personal protection devices such as eye, hand and hearing protectors, when performing any service or maintenance work.
8. Where replacement parts are necessary for periodic maintenance and servicing, genuine factory replacement parts must be used to restore your equipment to original specifications. The manufacturer will not be responsible for injuries or damages caused by use of unapproved parts and/or accessories.
9. A fire extinguisher and first aid kit should be kept readily accessible while performing maintenance on this equipment.
10. Periodically tighten all bolts, nuts and screws and check that all cotter pins are properly installed to ensure unit is in a safe condition.
11. Remember that well-maintained equipment is safer, will perform better, and provide longer service life!

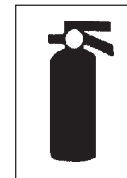

3 SAFETY SIGN LOCATIONS

The types of safety signs and locations on the equipment are shown in the illustration below. Good safety requires that you familiarize yourself with the various safety signs, the type of warning and the area, or particular function related to that area, that requires your SAFETY AWARENESS.



**ALWAYS REPLACE
MISSING OR
DAMAGED DECALS**

A

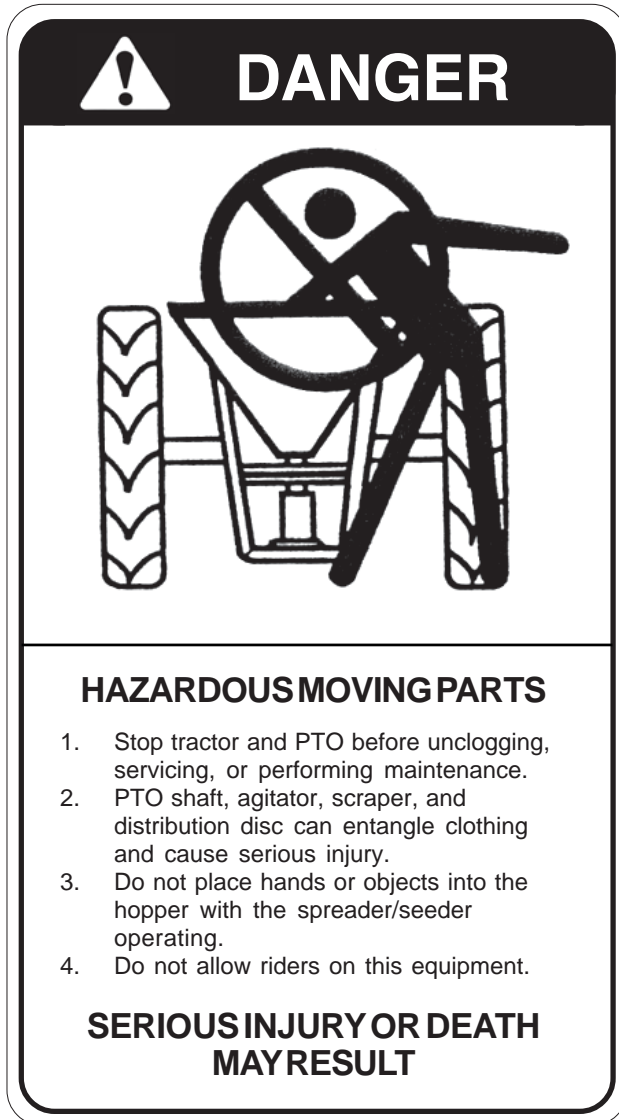

Location: Side of Hopper

B

ATTENTION: Check all bolts for tightness and grease before using the machine. Check bolts for tightness after 30 minutes the first time used. Check all bolts for tightness and grease before each additional use.

Location: Front Plate, Bottom of Hopper

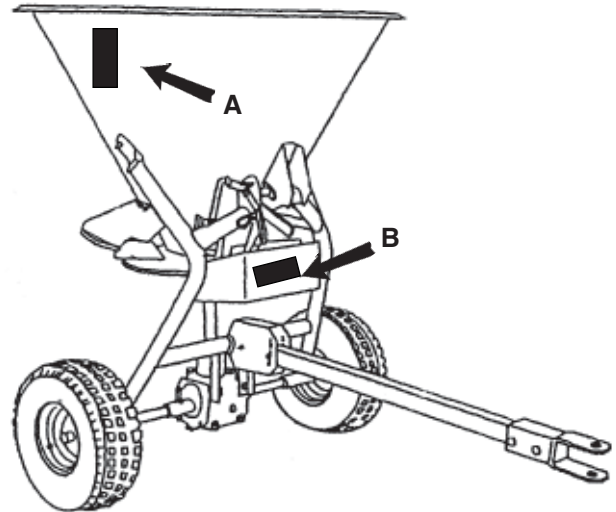

REMEMBER - If safety signs have been damaged, removed, become illegible or parts replaced without signs, new signs must be applied. New signs are available from your authorized dealer.

4 OPERATION



OPERATING SAFETY

1. Read and understand the Operator's Manual and all safety signs before operating, servicing, adjusting, repairing or unclogging.
2. Do not allow riders.
3. Keep hands, feet, hair and clothing away from moving parts.
4. Place all controls in neutral, stop tractor/ATV engine, set park brake, remove ignition key and wait for all moving parts to stop before servicing, adjusting, repairing or unclogging.
5. Place all tractor/ATV and machine controls in neutral before starting.
6. Always wear the appropriate personal safety equipment when operating equipment including but not limited to hard hat, safety shoes, face shield and heavy gloves.
7. Clear the area of bystanders, especially small children, before starting.
8. Do not operate on slopes or sidehills.
9. Keep all mechanical components in good condition. Do not operate with damaged components.
10. DO NOT place hands or objects into the hopper with the spreader/seeder operating.
11. Review safety instructions with all operators annually.

4.1 TO THE NEW OPERATOR OR OWNER

The Seeder / Spreader is the ideal implement for use when a PTO is not available. This pull type spreader can be pulled with small tractors, ATV's or a car rear hitch. This unit has a ground driven, cast iron, oil bath gearbox that can be disengaged when transporting. It is designed for surface spreading of granulated and powdered materials. It has 15" diameter tires that are 6" wide which makes this a "Turf Friendly" implement. This unit is a handy tool for farmers, landscapers and ranchers.

Be familiar with the machine before starting.

It is the responsibility of the owner or operator to read this manual and to train all other operators before they start working with the machine. Follow all safety instructions exactly. Safety is everyone's business. By following recommended procedures, a safe working environment is provided for the operator, bystanders and the area around the worksite. Untrained operators are not qualified to operate the machine.

Many features incorporated into this machine are the result of suggestions made by customers like you. Read this manual carefully to learn how to operate the machine safely and how to set it to provide maximum field efficiency. By following the operating instructions in conjunction with a good maintenance program, your Seeder/Spreader will provide many years of trouble-free service.

4.2 MACHINE COMPONENTS

The Seeder/Spreader consists of a hopper, frame, spreading disc, drawbar, gearbox, two wheels and a winddrift shield. The hopper is a one piece conical shaped hopper without seams. Frame is made from profiled pipes. The seeder/spreader is a ground driven unit. Power to the spreading disc and scraper is transmitted from the right side wheel through the gearbox.

4.3 ASSEMBLY

The machine is shipped from the factory completely assembled with the exception of the tongue. Refer to the drawing and parts list should it become necessary to disassemble the unit for repair or replacement of parts.

<u>REF.</u>	<u>DESCRIPTION</u>
1	Hopper
2	Frame
3	Spreading Disc
4	Spreading Adjustment
5	Drawbar
6	Wheels
7	Gearbox
8	Windrift Shield

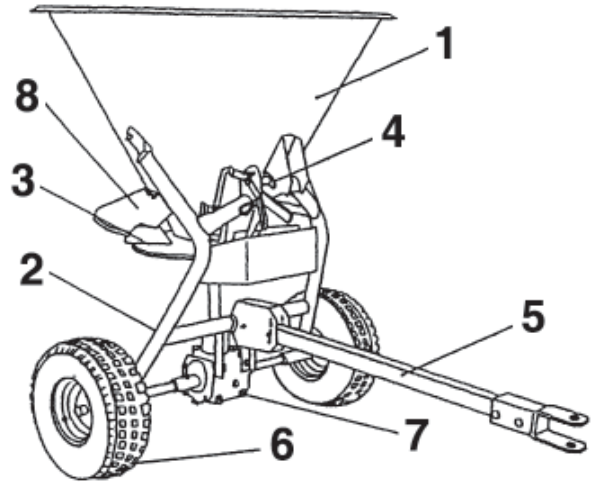

4.4 PRE-OPERATION CHECKLIST

Although there are no operational restrictions on the Seeder/Spreader when used for the first time, it is recommended that the following mechanical items be checked:

A. Before Operation:

1. Check all nuts, bolts and other fasteners. Tighten to their specified torque level.
2. Lubricate all grease fittings every ten (10) hours of operation.
3. Make sure that spreading discs and vanes are firmly mounted.
4. Check the condition of wheel type agitator.
5. Check the tire pressure.
6. Verify the level of oil in the gearbox and that the geardrive is working.

Remember that well-maintained equipment is safer, will perform better, and provide longer service life!

Efficient and safe operation of the Seeder/Spreader requires that each operator reads and understands the operating procedures and all related safety precautions outlined in this section. A pre-operation checklist is provided for the operator. It is important for both the personal safety and maintaining the good mechanical condition of the Seeder/Spreader that this checklist is followed.

Before operating the machine and each time thereafter, the following areas should be checked off:

1. Use only a small Agricultural tractor/ATV.
2. Check that the machine is properly attached to the tractor/ATV.
3. Check all pivot pins and fasteners; replace them as needed.
4. Lubricate all grease fittings every ten (10) hours of operation.

4.5 FIELD OPERATION



OPERATING SAFETY

1. Read and understand the Operator's Manual and all safety signs before operating, servicing, adjusting, repairing or unclogging.
2. Do not allow riders.
3. Keep hands, feet, hair and clothing away from moving parts.
4. Place all controls in neutral, stop tractor/ATV engine, set park brake, remove ignition key and wait for all moving parts to stop before servicing, adjusting, repairing or unclogging.
5. Place all tractor/ATV and machine controls in neutral before starting.
6. Always wear the appropriate personal safety equipment when operating equipment including but not limited to hard hat, safety shoes, face shield and heavy gloves.
7. Clear the area of bystanders, especially small children, before starting.
8. Do not operate on slopes or sidehills.
9. Keep all mechanical components in good condition. Do not operate with damaged components.
10. Before beginning operation, check that spreading discs and vanes are firmly mounted.
11. Check the tire pressure regularly.
12. Check the level of oil in the gearbox and make sure the geardrive is working.
13. Review safety instructions with all operators annually.

Each operator should review this section of the manual at the start of the season and as often as required to be familiar with the machine. When using, follow this procedure:

1. Review and follow the Pre-Operation Checklist.
2. Attach the tractor/ATV to the machine.
 - a. Connect clevis hitch to your towing vehicle (1 ⁷/₈" ball hitch is standard) Angle on the drawbar can be regulated using the pin (Ref. 1) and holes in hitch of frame.

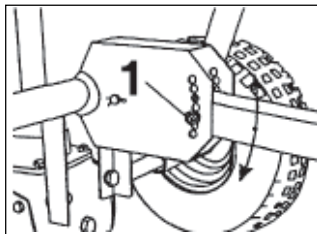

3. For regulating the quantity of material, there are two levers (Ref. 1L and 1R) which via pull rods (Ref. 2) change the position of the dampers (Ref. 3). Thereby the sizes of the holes are adjusted. You should use the spreading seed chart to determine the quantity of spreading material desired.

- a. For spreading to the left side, you close the left damper (Ref. 1L).
- b. For spreading to the right side, you close the right damper (Ref. 1R).
- c. For both sides spreading, you open both dampers (Ref. 1L and 1R).

It is recommended that you start with both sides spreading and then correct dependent on your need.

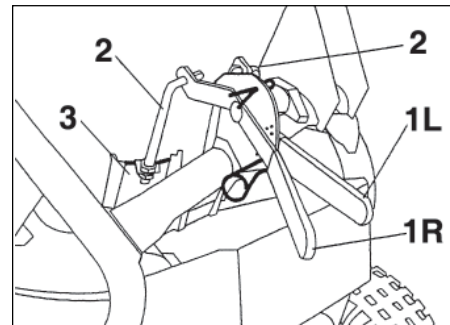

4.6 TRANSPORTING

TRANSPORT SAFETY

1. Make sure you are in compliance with all local regulations regarding transporting equipment on public roads and highways.
2. Make sure the SMV (Slow Moving Vehicle) emblem and all the lights and reflectors that are required by the local highway and transport authorities are in place, are clean and can be seen clearly by all overtaking and oncoming traffic.
3. Do not allow anyone to ride on the implement or tractor/ATV during transport.
4. Do not exceed 20 mph (32 kph). Reduce speed on rough roads and surfaces.
6. Always use hazard flashers on the tractor/ATV when transporting unless prohibited by law.

When transporting the machine, review and follow these instructions:

1. Be sure all bystanders are clear of the machine.
2. Be sure that the machine is securely attached to the tractor/ATV and all retainer pins are installed.
3. Clean the SMV emblem, lights and reflectors and be sure they are working.
4. Be sure you are in compliance with all applicable lighting and marking regulations when transporting. Check with your local authorities.
5. Be sure your machine can clearly be seen by overtaking and oncoming traffic.
6. Keep to the right and yield the right-of-way to allow faster traffic to pass. Drive on the road shoulder if permitted by law.
7. Do not allow riders.
8. Always use hazard flashers on the tractor/ATV when transporting unless prohibited by law.
9. It is advisable to disconnect drive and thereby the spreading disc before transporting.
 - a. In order to disconnect drive - nut should be unscrewed (Ref. 1) and take out the bolt (Ref. 2).

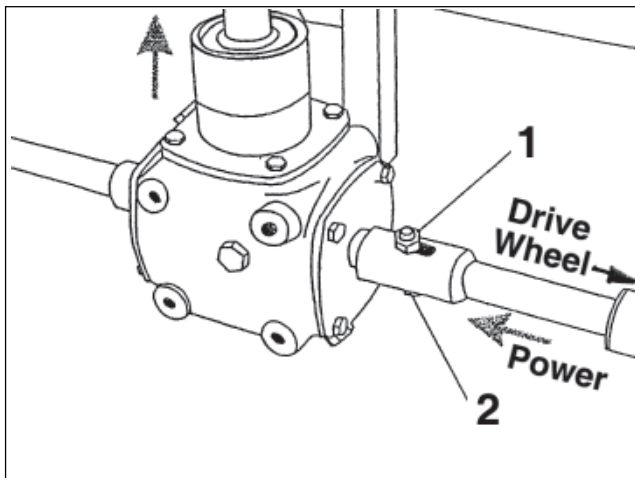

4.7 STORAGE



STORAGE SAFETY

1. Store the unit in an area away from human activity.
2. Do not permit children to play on or around the stored machine.
3. Store the unit in a dry, level area. Support the frame with planks if required.

After the season's use, the machine should be thoroughly inspected and prepared for storage. Repair or replace any worn or damaged components to prevent any unnecessary down time at the start of next season. To insure a long, trouble free life, this procedure should be followed when preparing the unit for storage:

1. Clear the area of bystanders, especially small children.
2. Thoroughly wash the machine using a pressure washer to remove all dirt, mud, debris and residue.
3. Inspect the Seeder/Spreader for damage. Repair or replace damaged parts.
4. Touch up all paint nicks and scratches to prevent rusting.
5. Move to storage area.
6. Select an area that is dry, level and free of debris.
7. Unhook from tractor/ATV.
8. If the Seeder/Spreader cannot be placed inside, cover with a waterproof tarpaulin and tie securely in place.
9. Store the Seeder/Spreader in an area away from human activity.
10. Do not allow children to play on or around the stored machine.

5 SERVICE AND MAINTENANCE



MAINTENANCE SAFETY

1. Follow ALL the operating, maintenance and safety information in the manual.
2. Support the machine with blocks or safety stands when working beneath it.
3. Follow good shop practices.
 - Keep service area clean and dry.
 - Be sure electrical outlets and tools are properly grounded.
 - Use adequate light for the job at hand.
3. Make sure there is plenty of ventilation. Never operate the engine of the tractor/ATV in a closed building. The exhaust fumes may cause asphyxiation.
4. Use only tools, jacks and hoists of sufficient capacity for the job.
5. Clear the area of bystanders, especially small children, when carrying out any maintenance and repairs or making any adjustments.
6. Never perform maintenance or service work such as lubricating, inspecting, clearing debris, etc., while the tractor/ATV engine is running. Shut off the tractor/ATV engine and remove the key before performing these functions

Good maintenance is your responsibility. Poor maintenance is an invitation to trouble.

DO NOT operate your Seeder/Spreader in poor mechanical condition or when in need of repair.

1. Check all bolts for tightness and grease the spreader at the greasing points before using the machine.
2. Check that spreading discs and vanes are firmly mounted and that the geardrive is working.
3. Check the condition of wheel type agitator.
4. Check the pressure in the tires and the level of oil in the gearbox.
5. Remember that well-maintained equipment is safer, will perform better, and provide longer service life!

5.1 SERVICE

5.1.1 LUBRICANTS

1. **Grease:**
Use an SAE multi-purpose high temperature grease with extreme pressure (EP) performance. Also acceptable is an SAE multipurpose lithium base grease.
2. **Storing Lubricants:**
Your machine can operate at top efficiency only if clean lubricants are used. Use clean containers to handle all lubricants. Store them in an area protected from dust, moisture and other contaminants.

5.1.2 GREASING

Use a Maintenance Checklist to keep a record of all scheduled maintenance.

1. Use a hand-held grease gun for all greasing.
2. Wipe grease fitting with a clean cloth before greasing to avoid injecting dirt and grit.
3. Replace and repair broken fittings immediately.
4. If fittings will not take grease, remove and clean thoroughly. Also clean lubricant passage. Replace fitting if necessary.

5.1.3 SERVICING INTERVALS

The period recommended is based on normal operating conditions. Severe or unusual conditions may require more frequent servicing.

Daily or 10 Hours

1. Check bolts for tightness after 30 minutes of use the first time used.
2. Lubricate all grease fittings and check all bolts for tightness before each use.
3. Empty the hopper then clean and wash thoroughly after every use.

5.2 MAINTENANCE

By following a good maintenance program, your equipment will last for many years.

REMINDER: Never perform maintenance or service work such as lubricating, inspecting, clearing debris, etc., while the tractor/ATV engine is running. Shut off the tractor/ATV engine and remove the key before performing these functions.

5.3 ORDERING PARTS

When replacement parts and service are required for your attachment, Gearmore recommends returning to the dealer from which the attachment was purchased. By going to the dealer, you are dealing with people that understand and know your attachment. Our dealers have the experience servicing these machines and stock the most common parts required to keep your attachment in top working condition.

Parts lists contained in this book have been prepared to help you when ordering spare and/or replacement parts. Your order will be filled promptly and accurately when the following information is provided:

1. Model and serial number of the unit. (This specifically identifies the equipment you have and permits us to verify the part numbers in your order.)
2. The **REF** number for each part. **REF** numbers on the parts list page correspond with the numbers shown on the illustration.
3. **Part Number** as it appears in the parts list.
4. The **Description** for the part as it appears on the parts list page.

The part ordered may have a new part number, or the part may have been replaced by a newer design with a different part number. This will be noted on your packing slip. Our purpose in doing this is to tell you that the parts are fully interchangeable. This will avoid any unnecessary correspondence or delay in processing your order. We suggest that you add any new number to your parts lists for future use.

All replacement parts must meet manufacturer's specifications. The manufacturer will not be responsible for injuries or damages caused by use of unapproved parts and/or accessories.

6 SPECIFICATIONS

6.1 MECHANICAL

Capacity:	350 lbs.
Spacing of axle wheels:	33"
Rotation of discs:	450 RPM
Number of vanes:	4
Height:	48"
Width:	40"
Length:	55"
Weight:	195#

SPECIFICATIONS ARE SUBJECT TO CHANGE WITHOUT NOTICE

SEED CHART LBS/ACRE

MATERIAL	SPREADING WIDTH (feet)	SETTING											SPEED MPH
		4	5	6	7	8	9	10	11	12	13	14	
Ammonium Nitrate	26'	119	230	341	450	559	668	776	904	1031	1257	1284	3
		67	131	194	257	318	381	442	515	587	660	731	6
UREA	26'	72	160	249	334	420	519	618	714	809	904	999	3
		40	91	141	190	240	296	353	407	460	515	569	6
Granulated Superphosphat	26'	82	169	255	382	507	626	745	942	1139	1337	1534	3
		47	96	146	217	289	357	416	528	650	762	875	6
Potassium Salt	13'			262	872	1490	1839	2187					3
				150	500	849	935	1246	1382	1653	1653	1788	6
Rye	26'	89	173	256	338	419	501	582	768	773	943	963	3
		50	98	146	193	239	286	332	386	440	495	548	6
Wheat	26'	71	138	205	270	335	401	466	542	619	754	770	3
		40	79	116	154	191	229	265	309	352	396	439	6
Rice	26'	144	278	413	545	676	808	939	1094	1248	1521	1554	3
		81	159	234	311	385	461	535	623	710	799	885	6
Sudan Grass	26'	95	184	273	360	447	543	621	723	825	1006	1029	3
		54	105	155	206	254	305	354	412	470	528	585	6
Lespedeza	26'	56	109	161	212	264	315	366	427	487	594	607	3
		32	62	91	122	150	180	209	243	277	312	310	6

6.2 BOLT TORQUE

CHECKING BOLT TORQUE

The tables shown below give correct torque values for various bolts and capscrews. Tighten all bolts to the torques specified in chart unless otherwise noted. Check tightness of bolts periodically, using bolt torque chart as a guide. Replace hardware with the same strength bolt.

ENGLISH TORQUE SPECIFICATIONS

Bolt Diameter "A"	Bolt Torque *					
	SAE 2		SAE 5		SAE 8	
	N.m	(lb-ft)	N.m	(lb-ft)	N.m	(lb-ft)
1/4"	8	(6)	12	(9)	17	(12)
5/16"	13	(10)	25	(19)	36	(27)
3/8"	27	(20)	45	(33)	63	(45)
7/16"	41	(30)	72	(53)	100	(75)
1/2"	61	(45)	110	(80)	155	(115)
9/16"	95	(70)	155	(115)	220	(165)
5/8"	128	(95)	215	(160)	305	(220)
3/4"	225	(165)	390	(290)	540	(400)
7/8"	230	(170)	570	(420)	880	(650)
1"	345	(225)	850	(630)	1320	(970)

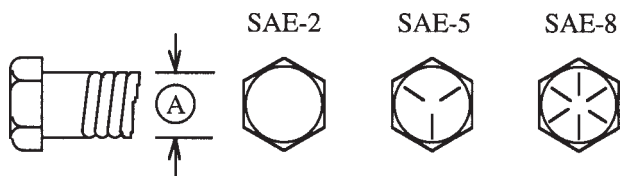

Torque figures indicated above are valid for non-greased or non-oiled threads and heads unless otherwise specified. Therefore, do not grease or oil bolts or capscrews unless otherwise specified in this manual. When using locking elements, increase torque values by 5%.

* Torque value for bolts and capscrews are identified by their head markings.

7 PARTS BREAKDOWN

7.1 GEARBOX

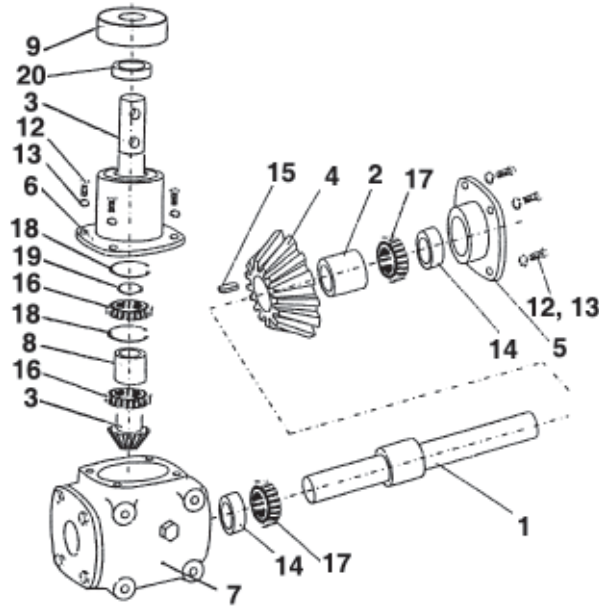

<u>REF #</u>	<u>QTY.</u>	<u>PART NO.</u>	<u>DESCRIPTION</u>
	1	RS/02-007/0	Gearbox Complete
1	1	RS/02-001/0	Horizontal Shaft
2	1	RS/02-002/0	Spacing Sleeve
3	1	RS/02-003/0	Gear Shaft
4	1	RS/02-004/0	Gearwheel
5	2	RS/02-005/0	Cover Complete
6	1	RS/02-006/0	Housing For Bearing
7	1	0500/01-001	Body
8	1	2029/06-005/0	Spacing Sleeve
9	1	2042/00-005/0	Gearbox Cover
12	12	PN-85/M-82105	Bolt N8 x 20 - 5.8 - B Fe/Zn 12c
13	12	PN-77/M-82008	Spring Washer Z8.2 Fe/Zn 12c
14	2	PN-72/M-86964	Sealing Ring A25 x 40 x 7
15	1	PN-77/M-85005	Prism Key 8 x 7 x 25
16	2	6007	Ball Bearing
17	2	30205	Taper Bearing
18	2	47262	Circlip I62
19	1	47135	Circlip E35
20	1	35x62x7	Oil Seal

7.2 SPREADER

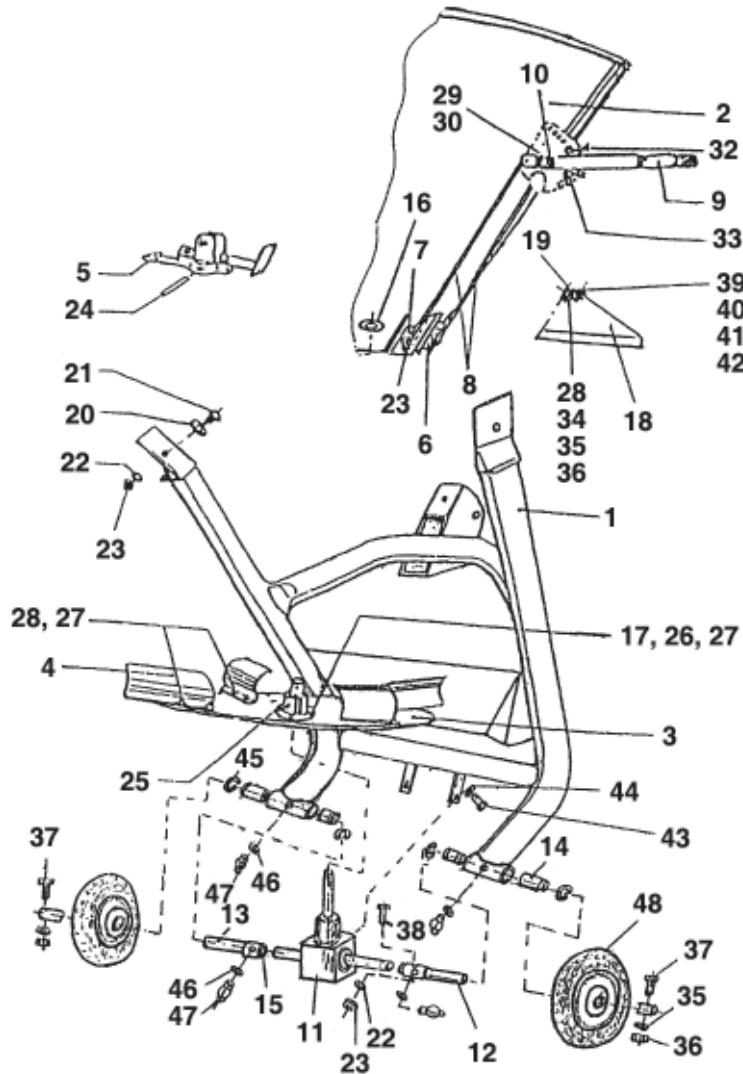

<u>REF #</u>	<u>QTY.</u>	<u>PART NO.</u>	<u>DESCRIPTION</u>
1	1	RS/01-00-000	Frame Complete (Welded)
2	1	RS/04-00--00	Hopper
3	1	2042/08-00-001	Spreading Plate
4	1	2042/08-00-002	Vane
5	1	2029/04-00-002/0	Belt Stretcher
6	1	2029/00-00-005	Left Damper
7	1	2029/00-00-006	Right Damper
8	2	2042/00-00-003	Regulation Lever
9	2	2042/00-00-004	Damper Lever
10	1	2029/00-05-00	Epileptic Knob
11	1	RS/02-00-000	Gearbox Complete
12	1	RS/00-00-100	Right Axle Shaft (Half Shaft)
13	1	RS/00-00-200	Left Axle Shaft (Half Shaft)

<u>REF #</u>	<u>QTY.</u>	<u>PART NO.</u>	<u>DESCRIPTION</u>
14	4	RS/00-00-001	Bearing Sleeve
15	2	RS/00-00-002	Axle Shaft Sleeve
16	1	2029/00-00-007	Spacing Washer
17	1	2029/07-00-002	Hub Plate
18	1	2012/00-00-003	Cover Plate
19	3	2012/00-00-009	Cover Support
20	3	2042/00-00-007	Special Washer
21	3	PN-89/M-82406	Bolt
22	4	PN-77/M-82008	Spring Washer
23	8	PN-86/M-82144	Nut
24	1	PN-89/M-85023	Spring Pin/Rolled Pin
25	1	PN-89/M-85023	Spring Pin/Rolled Pin
26	4	PN-85/M-82105	Bolt
27	12	PN-85/M-82175	Self Locking Nut
28	11	PN-85/M-82105	Bolt
29	1	PN-89/M-82406	Bolt
30	1	PN-78/M-82005	Washer
32	1	PN-ISO/7072	Split Pin
33	1	PN-76/M-82001	Split Pin
34	3	PN-78/M-82005	Round Washer
35	5	PN-77/M-82008	Spring Washer
36	5	PN-86/M-82144	Nut
37	2	PN-85/M-82101	Bolt
38	1	PN-85/M-82101	Bolt
39	3	PN-78/M-82105	Bolt
40	3	PN-85/M-82105	Round Washer
41	3	PN-78/M-82008	Spring Washer
42	3	PN-86/M-82144	Nut
43	2	PN-85/8-82-105	Bolt
44	2	PN-78/M-82008	Spring Washer
45	4	PN-81/04-85111	Compression Ring
46	4	PN-69/M-86970	Fibreboard Gasket
47	4	PN-76/M-86002	Grease Nipple
48	2		Rubber Wheel

8 LIMITED WARRANTY



GEARMORE, INC., warrants each new Gearmore product to be free from defects in material and workmanship for a period of twelve (12) months from date of purchase to the original purchaser. This warranty shall not apply to implements or parts that have been subject to misuse, negligence, accident, or that have been altered in any way.

Our obligation shall be limited to repairing or replacement of any part, provided that such part is returned within thirty (30) days from date of failure to Gearmore through the dealer from whom the purchase was made, transportation charges prepaid.

This warranty shall not be interpreted to render us liable for injury or damages of any kind or nature, direct, consequential or contingent, to person or property. This warranty does not extend to loss of crops, loss because of delay in harvesting or any other expenses, for any other reasons.

Gearmore in no way warrants engines, tires, or other trade accessories, since these items are warranted separately by these respective manufacturers.

Gearmore reserves the right to make improvements in design or changes in specification at any time, without incurring any obligations to owners or units previously sold.

GEARMORE, INC.
13477 Benson Ave.
Chino, CA 91710

Always refer to and heed machine operating warning decals on machine.

The serial number of this product is stored in our computer database, thus submitting a warranty registration card is not required.