

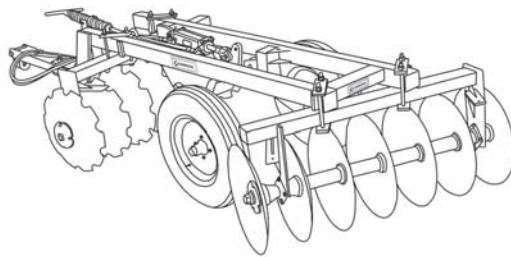

OFFSET DISC

PULL TYPE



Assembly/Operator's & Parts Manual For 300 Series

June 2007

TABLE OF CONTENTS

SECTION	DESCRIPTION	PAGE
1	Introduction	1
1.1	Operator's Responsibility	1
1.2	Serial Number Location	1
2	Safety	2-6
2.1	General Safety	3
2.2	Equipment Safety Guidelines	4
2.3	Safety Training	4
2.4	Preparation	5
2.5	Operating Safety	5
2.6	Transport Safety	6
2.7	Storage Safety	6
2.8	Maintenance Safety	6
3	Initial Assembly	7-8
3.1	Bleeding Axle Cylinders	7
3.2	Gang Bar Installation	7
3.3	Lateral Adjustment	7
3.4	Scraper Assembly	7
3.5	Outrigger Assembly	7
3.6	Gang Assembly	8
4	Operation	9
4.1	Tractor & Machine Preparation	9
4.2	Harrow Preparation	9
4.3	Tractor Preparation	9
4.4	Pre-Operation Checklist	9
5	Adjustments	10-11
5.1	Setup Procedures	10
5.2	Tongue Adjustment	11
5.3	Leveling Crank & Spring Assy	11
6	Trouble Shooting	12
7	Maintenance	13
7.1	Lubrication	13
7.2	Gang Bolts	13
8	Parts Lists	14
8.1	G300 Main Frame	14-15
8.2	G300 Gang Assembly	16-18
9	Limited Warranty	19

1 INTRODUCTION

Congratulations on your choice of a pull type offset disc. This equipment is manufactured to precise specifications using the best quality parts and materials available. With proper care and maintenance, this piece of equipment should last for many years. Before operating this machine, thoroughly read and become familiar with this manual.

1.1 OPERATOR'S RESPONSIBILITY

Safe, efficient and trouble free operation of your Disc requires that you and anyone else who will be operating or maintaining the machine, read and understand the Safety, Operation, Maintenance and Troubleshooting information contained within the Operator's Manual.

It is the responsibility of the user/purchaser to lubricate and maintain this product according to the schedule in this manual. The user is responsible for inspecting the machine, and for having parts repaired or replaced when continued use of the product would cause damage or excessive wear to other parts. All fasteners should be checked and tightened periodically and as necessary. When supporting the frame or the machine, use stands that are capable of handling the weight of the assembly. Insure that the supports are on a clean, dry surface. It is the user's responsibility to deliver this product to the dealer when repairs that are covered by the standard warranty need to be made.

Keep this manual handy for frequent reference and to pass on to new operators or owners. Call your Gearmore dealer if you need assistance, information or additional copies of the manuals.

OPERATOR ORIENTATION - The directions left, right, front and rear, as mentioned throughout this manual, are as seen from the driver's seat and facing in the direction of travel.

1.2 SERIAL NUMBER LOCATION

Always give your dealer the serial number of your Disc when ordering parts or requesting service or other information. The serial number plate is located where indicated. Please mark the number in the space provided for easy reference.

Serial Number Plate

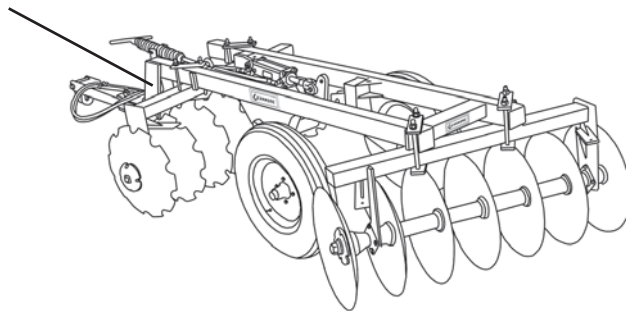

DATE OF PURCHASE: _____

MODEL NUMBER: _____

SERIAL NUMBER: _____

2 SAFETY

SAFETY ALERT SYMBOL

This Safety Alert symbol means **ATTENTION! BECOME ALERT! YOUR SAFETY IS INVOLVED!**

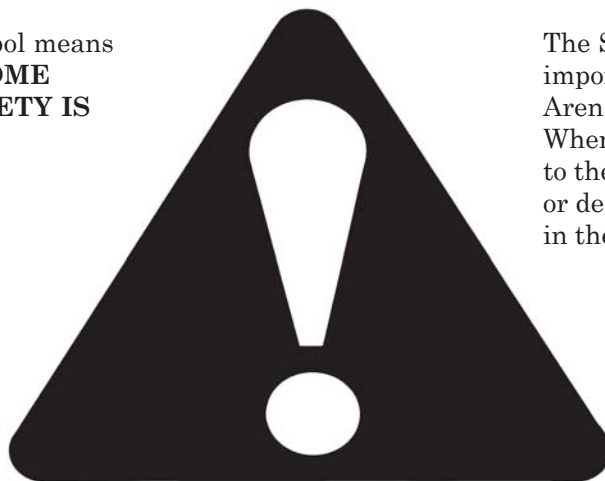

The Safety Alert symbol identifies important safety messages on the Arena-Comb and in the manual. When you see this symbol, be alert to the possibility of personal injury or death. Follow the instructions in the safety message.

Why is SAFETY important to you?

3 Big Reasons

Accidents Disable and Kill
Accidents Cost
Accidents Can Be Avoided

SIGNAL WORDS:

Note the use of the signal words **DANGER**, **WARNING** and **CAUTION** with the safety messages. The appropriate signal word for each message has been selected using the following guide-lines:

SI NO LEE INGLES, PIDA AYUDA A AIGUIEN QUE SI LO LEA PARA QUE LE TRADUZCA LAS MIDIDAS DE SEGURIDAD.

DANGER - Indicates an imminently hazardous situation that, if not avoided, will result in death or serious injury. This signal word is to be limited to the most extreme situations typically for machine components which, for functional purposes, cannot be guarded.

WARNING - Indicates a potentially hazardous situation that, if not avoided, could result in death or serious injury, and includes hazards that are exposed when guards are removed. It may also be used to alert against unsafe practices.

CAUTION - Indicates a potentially hazardous situation that, if not avoided, may result in minor or moderate injury. It may also be used to alert against unsafe practices.

If you have any questions not answered in this manual or require additional copies or the manual is damaged, please contact your dealer.

2.1 GENERAL SAFETY

YOU are responsible for the **SAFE** operation and maintenance of your Disc. **YOU** must ensure that you and anyone else who is going to operate, maintain or work around the Disc be familiar with the operating and maintenance procedures and related **SAFETY** information contained in this manual. This manual will take you step-by-step through your working day and alerts you to all good safety practices that should be adhered to while operating the Disc.

Remember, **YOU** are the key to safety. Good safety practices not only protect you, but also the people around you. Make these practices a working part of your safety program. Be certain that **EVERYONE** operating this equipment is familiar with the recommended operating and maintenance procedures and follows all the safety precautions. Most accidents can be prevented. Do not risk injury or death by ignoring good safety practices.

- Disc owners must give operating instructions to operators or employees before allowing them to operate the machine, and at least annually there after per OSHA (Occupational Safety and Health Administration) regulation 1928.57.
- The most important safety feature on this equipment is a **SAFE** operator. It is the operator's responsibility to read and understand **ALL** Safety and Operating instructions in the manual and to follow these. Most accidents can be avoided.
- A person who has not read and understood all operating and safety instructions is not qualified to operate the machine. An untrained operator exposes himself and bystanders to possible serious injury or death.
- **DO NOT** modify the equipment in any way. Unauthorized modification may impair the function and/or safety and could affect the life of the equipment.
- **Think SAFETY! Work SAFELY!**

1. Read and understand the Operator's Manual and all safety signs before operating, maintaining or adjusting the disc.



2. Have a first-aid kit available for use should the need arise and know how to use it.



3. Have a fire extinguisher available for use should the need arise and know how to use it.



4. Wear appropriate protective gear. This list includes but is not limited to:

- A hard hat
- Protective shoes with slip resistant soles
- Protective goggles, glasses or face shield
- Heavy gloves
- Protective clothing

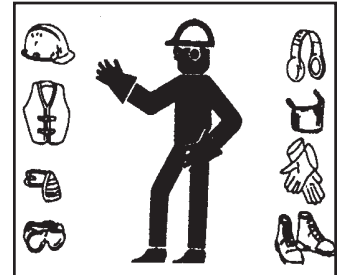

5. Install and secure all guards before starting.

6. **DO NOT** allow riders.

7. Wear suitable ear protection for prolonged exposure to excessive noise.



8. Place all controls in neutral, stop tractor engine, set park brake, remove ignition key and wait for all moving parts to stop before servicing, adjusting, or repairing.

9. Clear the area of people, especially small children, before starting.

10. Review safety related items annually with all personnel who will be operating or maintaining the Disc.

2.2 EQUIPMENT SAFETY GUIDELINES

Safety of the operator and bystanders is one of the main concerns in designing and developing a machine. However, every year many accidents occur which could have been avoided by a few seconds of thought and a more careful approach to handling equipment. You, the operator, can avoid many accidents by observing the following precautions in this section. To avoid personal injury or death, study the following precautions and insist those working with you, or for you, follow them.

- **NEVER** use alcoholic beverages or drugs which can hinder alertness or coordination while operating this equipment. Consult your doctor about operating this machine while taking prescription medications.
- **Under no circumstances should young children be allowed to work with this equipment. Do not allow persons to operate or assemble this unit until they have read this manual and have developed a thorough understanding of the safety precautions and of how it works.** Review the safety instructions with all users annually.
- This equipment is dangerous to children and persons unfamiliar with its operation. The operator should be a responsible, properly trained and physically able person familiar with farm machinery and trained in this equipment's operations. If the elderly are assisting with farm work, their physical limitations need to be recognized and accommodated.
- Use a tractor equipped with a Roll Over Protective Structure (ROPS) and a seat belt.
- **NEVER** exceed the limits of a piece of machinery. If its ability to do a job, or to do so safely, is in question - **DON'T TRY IT.**
- Do not modify the equipment in any way. Unauthorized modification may impair the function and/or safety and could affect the life of the equipment.

In addition to the design and configuration of this implement, including Safety Signs and Safety Equipment, hazard control and accident prevention are dependent upon the awareness, concern, prudence and proper training of personnel involved in the operation, transport, maintenance and storage of the machine. Refer also to Safety Messages and operation instruction in each of the appropriate sections of the tractor and machine manuals. Pay close attention to the Safety Signs affixed to the tractor and the machine.

Think SAFETY! Work SAFELY!

2.3 SAFETY TRAINING

Safety is a primary concern in the design and manufacture of our products. Unfortunately, our efforts to provide safe equipment can be wiped out by a single careless act of an operator or bystander.

It has been said, "*The best safety feature is an informed, careful operator.*" We ask you to be that kind of an operator. It is the operator's responsibility to read and understand ALL Safety and Operating instructions in the manual and to follow these. Accidents can be avoided.



Working with unfamiliar equipment can lead to careless injuries. Read this manual, and the manual for your tractor, before assembly or operating, to acquaint yourself with the machines. If this machine is used by any person other than yourself, or is loaned or rented, it is the machine owner's responsibility to make certain that the operator, prior to operating:

- a. Reads and understands the operator's manuals.
- b. Is instructed in safe and proper use.

Know your controls and how to stop tractor, engine and machine quickly in an emergency. Read this manual and the one provided with your tractor. Train all new personnel and review instructions frequently with existing workers. Be certain only a properly trained and physically able person will operate the machinery. A person who has not read and understood all operating and safety instructions is not qualified to operate the machine. An untrained operator exposes himself and bystanders to possible serious injury or death. If the elderly are assisting with farm work, their physical limitations need to be recognized and accommodated.

2.4 PREPARATION

1. Never operate the tractor and machine until you have read and completely understand this manual, and the Tractor Operator's Manual.

2. Personal protection equipment, including hard hat, safety glasses, safety shoes and gloves are recommended during assembly,



installation, operation, adjustment, maintaining, repairing, removal or moving the implement. **DO NOT** allow long hair, loose fitting clothing or jewelry to be around equipment.

3. **PROLONGED EXPOSURE TO LOUD NOISE MAY CAUSE PERMANENT HEARING LOSS!**

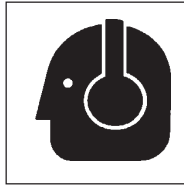

Tractors with or without equipment attached can often be noisy enough to cause permanent, partial hearing loss. We recommend that you wear hearing protection on a full-time basis if the noise in the Operator's position exceeds 80db. Noise over 85db on a long-term basis can cause severe hearing loss. Noise over 90db adjacent to the Operator over a long-term basis may cause permanent, total hearing loss.

NOTE: Hearing loss from loud noise (from tractors, chain saws, radios, and other such sources close to the ear) is cumulative over a lifetime without hope of natural recovery.

4. Operate the machine only with a tractor equipped with an approved Roll-Over Protective Structure (ROPS). Always wear your seat belt. Serious injury or even death could result from falling off the tractor --- particularly during a turn-over when the operator could be pinned under the ROPS or the tractor.



5. Clear working area of stones, branches or hidden obstacles that might be hooked or snagged, causing injury or damage.
6. Operate only in daylight or good artificial light.
7. Be sure machine is properly mounted, adjusted and in good operating condition.

2.5 OPERATING SAFETY

All things with moving parts are potentially hazardous. There is no substitute for a cautious, safe-minded operator who recognizes potential hazards and follows reasonable safety practices.

If a safety shield or guard is removed for any reason, it must be replaced before the machine is again operated.

When the use of hand tools is required to perform any part of assembly, installation, adjustment, maintaining, repairing, removal, or moving, be sure the tools used are designed and recommended by the tool manufacturer for that specific task.

Always use two people to handle heavy, unwieldy components during assembly, installation, removal, or moving.

Never place any part of your body where it would be in danger if movement should occur during assembly, installation, operation, maintaining, repairing, removal, or moving.

Never place yourself between the tractor and machine while implement is in operation.

Do not walk or work under a raised machine or attachment unless it is securely blocked or held in position. Do not depend on the tractor hydraulic system to hold the machine or attachment in place.

A heavy load can cause instability of the tractor. Use extreme care during travel. Slow down on turns and watch out for bumps. The tractor may need front counterweights to counterbalance the weight of the machine.

Never use alcoholic beverages or drugs, which can hinder alertness or coordination, while operating this equipment. Consult your doctor about operating this machine while taking prescription medications.

Do not allow riders on the machine or tractor at any time. There is no safe place for any riders.

Before you operate the machine, check over all pins, bolts and connections to be sure all are securely in place. Replace any damaged or worn parts immediately.

Clear the work area of objects which might be picked up and snagged or entangled in the machine.

Keep hands, feet, hair, jewelry, and clothing away from all moving and/or rotating parts.

2.6 TRANSPORT SAFETY

1. Comply with state and local laws governing highway safety and movement of farm machinery on public roads.
2. The use of flashing amber lights is acceptable in most localities. However, some localities prohibit their use. Local laws should be checked for all highway lighting and marking requirements.
3. At all times, when driving the tractor and equipment on the road or highway under 20 mph (32 kph) use flashing amber warning lights and a slow moving vehicle (SMV) identification emblem. Do not exceed 20 mph (32 kph). Reduce speed on rough roads and surfaces.
4. Plan your route to avoid heavy traffic.
5. To transport the machine, extend the axle cylinders and place the transport pin into the transport slots.
6. Do not drink and drive.
7. Be a safe and courteous driver. Always yield to oncoming traffic in all situations, including narrow bridges, intersections, etc. Watch for traffic when operating near or crossing roadways.
8. Turn into curves or go up or down hills only at a low speed and at a gradual steering angle. Make certain that at least 20% of the tractor's weight is on the front wheels to maintain safe steering. Slow down on rough or uneven surfaces.
9. Never allow riders on either tractor or machine.

2.7 STORAGE SAFETY

1. Store the unit in an area away from human activity.
2. Do not permit children to play on or around the stored machine.
3. Store the unit in a dry, level area. Support the frame with planks if required.

2.8 MAINTENANCE SAFETY

1. Good maintenance is your responsibility. Poor maintenance is an invitation to trouble.
2. Follow good shop practices.
 - Keep service area clean and dry.
 - Be sure electrical outlets and tools are properly grounded.
 - Use adequate light for the job at hand.
3. Make sure there is plenty of ventilation. Never operate the engine in a closed building. The exhaust fumes may cause asphyxiation.
4. Before working on this machine, shut off the engine, set the brakes, and remove the ignition key.
5. Never work under equipment unless it is blocked securely.
6. Use personal protection devices such as eye, hand and hearing protectors, when performing any service or maintenance work.
7. Where replacement parts are necessary for periodic maintenance and servicing, genuine factory replacement parts **must** be used to restore your equipment to original specifications. The manufacturer will not be responsible for injuries or damages caused by use of unapproved parts and/or accessories.
8. A fire extinguisher and first aid kit should be kept readily accessible while performing maintenance on this equipment
9. Periodically tighten all bolts, nuts and screws and check that all cotter pins are properly installed to ensure unit is in a safe condition.
10. When completing a maintenance or service function, make sure all safety shields and devices are installed before placing unit in service.

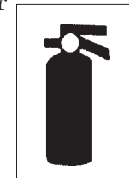
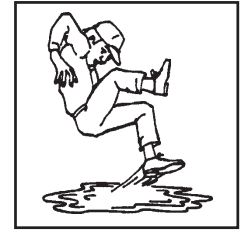

3 INITIAL ASSEMBLY

Bolt the tongue to the drawbar centered with the main frame. You may need to adjust the tongue right or left in final adjustment of the harrow. Clamp the hydraulic hoses to the tongue with the clamp provided.

3.1 BLEEDING AXLE CYLINDERS

Relieve hydraulic pressure by turning engine off and moving the hydraulic control levers in both directions before attaching or detaching hoses from the breakaway couplers. The first time the harrow is connected to a tractor hydraulic system, the cylinders should be cycled several times to purge the air from the system. Then check the oil level in the tractor hydraulic reservoir and add oil if needed.

3.2 GANG BAR INSTALLATION

Locate the front gang mounting brackets under the frame in alignment with the frame mounting brackets. Bolt the gang brackets to the left side of the frame, then align the right hand side and fasten gang bracket to frame bracket with bolts provided. Position, the rear gang in an offset location to the right of center and bolt to the mainframe brackets with bolts provided. (Refer to illustration on page).

3.3 LATERAL ADJUSTMENT (Between Front & Rear Gangs)

On standard gangs, the left rear blade should be approximately $\frac{2}{3}$ of the distance between the first and second blades on the left front. On tapered gangs, the left rear is normally set to run between the second and third blades of the front gang. (See Fig. 1).

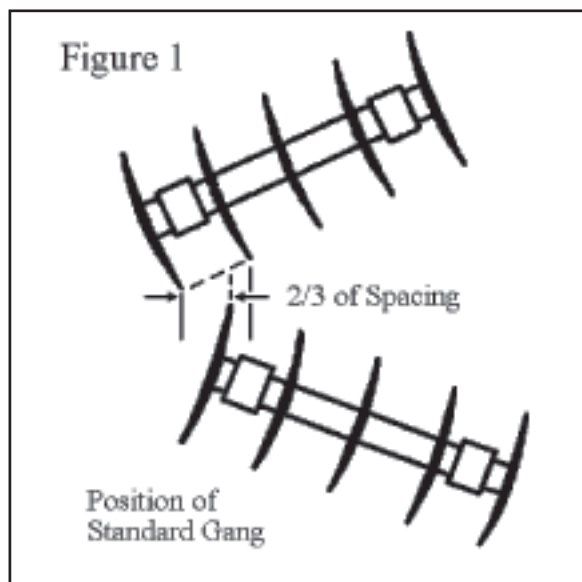

3.4 SCRAPER ASSEMBLY

Scrapers are assembled at the factory, but may need final adjustment depending on field conditions. Adjust individual scraper blades for fit against disc blades. The scraper point should be slightly closer to the disc than the rear of the scraper blade.

3.5 OUTRIGGER ASSEMBLY

The outrigger blade can easily be attached to the outside blade on the right end of the rear gang by the following procedure:

1. Remove the four(4) bolts from the spacer weldment and slide them into the bumper washer.
2. Place the spacer weldment over the bolts, replace washer and nuts, and tighten all four (4) bolts equally to insure proper alignment.
3. Place disc blade, end plate, lock washer, and nut on bolt stud.
4. Tighten this and all others securely (See Fig. 2).

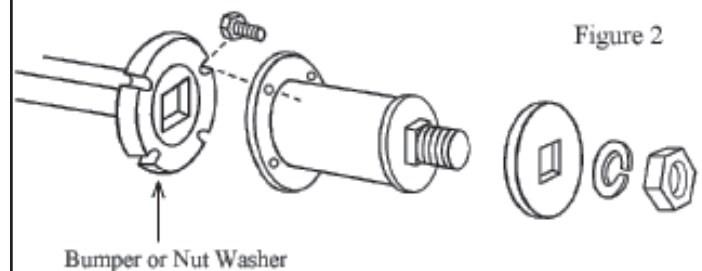

4 OPERATION

4.1 TRACTOR AND MACHINE PREPARATION

Offset Disc Harrows with standard gang arrangement are designed for one-way operation where the previous pass is always to the left of the direction of travel. This method of operation will leave a furrow made by the right rear on each pass. This furrow is filled in by soil thrown by the left rear blade on subsequent passes. It is important that the proper relationship between the front and rear gangs be maintained. This insures proper furrow filling and equal coverage by the rear gangs on the banks left by the front gangs, which helps keep the harrow straight and provide uniform breaking. For good furrow filling, the tractor should be driven so that the front left blade runs in the furrow from the previous pass.

Other factors affecting furrow filling and level surfacing include:

- ~ Soil texture and density
- ~ Ground speed
- ~ Cutting angle
- ~ Depth of penetration

Any change in any of these variables could cause a need for further adjustment.

4.2 HARROW PREPARATION

This harrow should be hitched to a tractor having a drawbar free to swing right and left. This minimizes side draft and permits shorter right turns when the harrow is raised. **Acute right turns with the harrow in the ground must be avoided**, as this creates excessive force on the harrow. Turns to the left can easily be made with the harrow in the ground, as this is an advantage of an offset harrow.

Before using this or any new machine, check for completeness and tightness of all bolts, especially gang and hanger bolts. If your disc harrow has been in storage, lubricate properly (*see lubrication section*).

4.3 TRACTOR PREPARATION

The disc harrows come standard with a swivel type clevis hitch. Set your tractor drawbar so it is free to swing. However, be sure it is pinned when for road transport.

For narrow width harrows, it will be necessary to make tractor tread width a minimum if the harrow is to trail directly behind the tractor. A common practice on narrower widths is to let the left rear wheel of the tractor run in the furrow from the previous round.

HITCHING:

For ease of hitching, the harrow should be on the ground before it is attached to or detached from the tractor. Back the tractor to the harrow, and raise the tongue into alignment by utilizing the crank.

To detach, the harrow should be on the ground. Adjust the crank and remove the hitch pin, detach the hydraulic hoses, and drive away.

4.4 PRE-OPERATION CHECKLIST

Efficient and safe operation of the Disc requires that each operator reads and understands the operating procedures and all related safety precautions outlined in this manual. A pre-operation checklist is provided for the operator. It is important for both the personal safety and maintaining the good mechanical condition of the Disc that this checklist is followed. Before operating the machine and each time thereafter, the following areas should be checked off:

- √ Use only a tractor of the recommended horsepower on the machine.
- √ Check that the machine is properly attached to the tractor.
- √ Be sure extra weights are mounted on the front of the tractor if required.
- √ Check to be sure there no damaged or broken parts. Repair or replace as required.
- √ Check for entangled material. Remove this material.

5 ADJUSTMENTS

Due to their design, offset disc harrows require some adjustments not common to tandem harrows. To obtain efficient operation, certain adjustments are necessary to correct for side draft, uneven penetration, and leveling. Your offset harrow has adjusting features that will create efficient operation under a variety of different conditions.

SIDE DRAFT

Side draft is probably the most noticeable problem you will encounter. With an understanding of the causes, adjustment becomes easier. The main factors contributing to side draft are:

1. The rear gangs always work in looser soil than the front gangs.
2. Improper weight may be applied to either the front or rear gangs.
3. Improper tongue adjustment.

With approximately the same angle in both front and rear gangs, the front gangs will have a greater thrust against them, tending to push the disc to the left. This is due to the above mentioned factors. To obtain no side draft, this thrust must be counteracted by thrust in the opposite direction from the rear gangs. Since there are several factors affecting side draft, it is important to only make one adjustment at a time. When your harrow is properly adjusted for minimum side draft, total draft requirements will be less. Further explanation of these factors is covered in following sections.

5.1 RECOMMENDED INITIAL SETUP PROCEDURES

The procedure assumes the harrow has been assembled correctly and lateral position of the front and rear gangs is correct.

1. Unpin tractor drawbar so it swings freely.
2. For medium to heavy discing, set the front gang in the middle angle position and the rear gang in the full angle position.
3. Check position of the gangs for the proper lateral position by lowering the disc to the ground so the blades scratch the surface when the disc is drawn forward. Watch to see if the rear blades will cut between the front blades.
4. Pull disc forward until desired operating depth is reached.
5. If disc trails to the left slightly, add more pressure to the rear gang with the leveling crank and reduce the angle in the front gangs.
6. If disc trails to the left excessively, move the tongue to the left on the drawbar.
7. If side draft or tracking is still not correct, refer to the Trouble Shooting Chart.

5.2 TONGUE ADJUSTMENT

Positioning the tongue is one of the most important adjustments of an offset harrow. It can be moved to either the right or the left. With the tongue in its normal position, moving the tongue to the right will move the harrow to the left offset position behind the tractor. This will increase the front gang cutting angle and decrease the rear gang cutting angle. Moving the harrow to the extreme left offset position will cause a side draft on the tractor, tending to turn it clockwise. Moving the tongue to the left has the opposite affect as described above.

Soil conditions and depth of penetration are factors that also determine tongue location for minimum or no side draft. Generally, when discing in soft fields with deeper penetration, the best tongue position for no side draft will be farther to the right, as opposed to discing in firm soil with shallow penetration.

Gang cutting angle is an important adjustment in regards to penetration and side draft. The front and rear gang bars both have angular adjustments of up to 46 degrees. Normally, an extra 5 degrees of rear gang setting will provide the extra thrust required to eliminate side draft in many conditions. For light discing conditions, the front gang is usually set in the minimum angle with the rear gang set in the middle angle position.

Remember that making an angle change will have a tendency to make an opposite change in the other gang. Increasing the rear angle will move the back of the disc to the right. Increasing the front angle will move the rear of the disc to the left.

NOTE: When changing gang angles, be sure to thoroughly retighten all bolts.

5.3 LEVELING CRANK AND SPRING ASSEMBLY

This assembly can be adjusted to provide proper balance while supporting the disc, and to provide for weight transfer to the rear gangs.

When the disc is in the raised position, a level condition can be obtained by adjusting the length of the rod assembly.

During operation, the amount of weight on the rear gangs greatly affects disc performance.

The hitch-leveling crank provides the easiest and most significant adjustment of the disc. It should be adjusted so the disc is level in the transport position as well as in the working position. Since it controls the front gang to the rear gang leveling relationship, it affects the trailing of the disc while working. Lowering the front end of the disc allows the right side of the front gang to cut deeper, causing the disc to swing to the left. Raising the front end will have the opposite affect, causing the disc to swing to the right. To obtain proper cutting and covering, this control should be adjusted so the left blade of the rear gang fills in the furrow made by the outside blade of the front gang.

If disc does not perform properly, refer to the adjusting and operating section and check that all adjustments conform to the recommendations made. When making any adjustment keep in mind the previous setting in case the adjustment does not correct the problem. Always make two rounds before evaluating the effect of a change in a given setting.

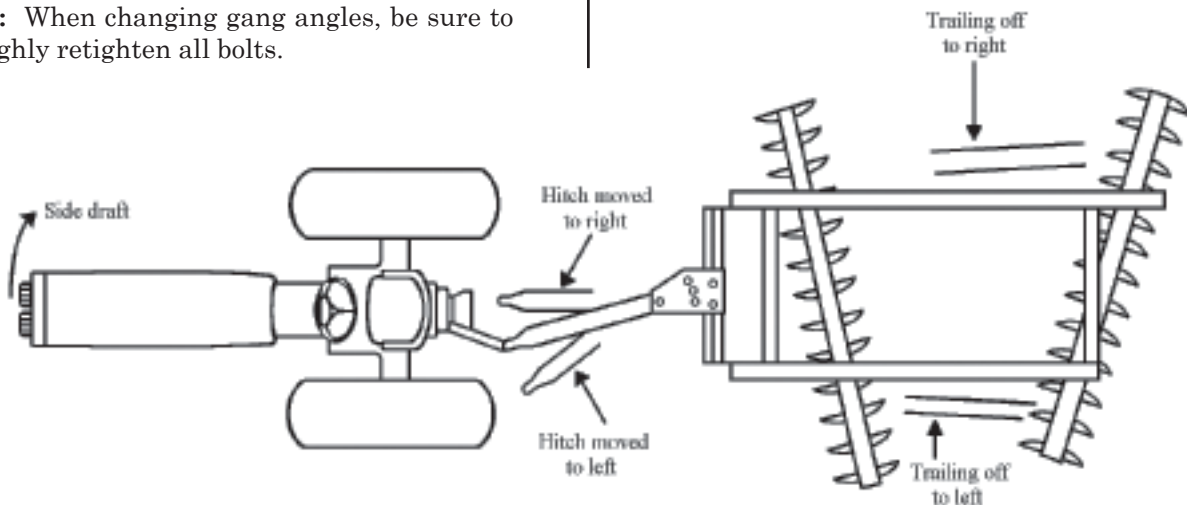

6 TROUBLE SHOOTING

PROBLEM	POSSIBLE REMEDY
SIDE DRAFT	
Hitch crank not properly adjusted Fixed or pinned drawbar Swinging drawbar against stop to left Too much angle in front gang or too little angle in rear gang	<ul style="list-style-type: none"> • Turn hitch crank to raise/lower the front gangs • Use swinging drawbar • Move hitch to left • Reduce front gang angle or increase rear gang angle
DISC TRAILS OFF TO LEFT	
Front gang overpowering disc	<ul style="list-style-type: none"> • Use leveling crank to raise front of disc • Use higher tractor hitch point or lower hitch pin pivot hole on disc drawbar • Move hitch to right • Reduce front gang angle or increase rear gang angle
DISC TRAILS OFF TO RIGHT	
Rear gang overpowering disc	<ul style="list-style-type: none"> • Use leveling crank to lower front of disc • Use lower tractor hitch point or use higher hitch pin pivot hole on disc drawbar • Move hitch to left • Increase front gang angle or decrease rear gang angle
NOT FILLING FURROW ON LEFT SIDE	
Speed too slow for soil conditions Rear of disc tracking too far to right Tractor being driven too far to right Rear gang set incorrectly laterally	<ul style="list-style-type: none"> • Increase speed • Slide tongue to left to reduce angle in rear and/or adjust leveling crank • Drive tractor so that left front disc is in the edge of the furrow • Move rear gang to left or right. On standard gang models the left rear blade should be approx. 2/3 the distance between the first two blades of left front gang. It should be set to cut out balk completely. On tapered blade models, the left rear blade should be approx. 2/3 the distance between the 2nd and 3rd blades of the left front gang.
NOT DISCING LEVEL	
Front & rear gangs not operating at same depth	<ul style="list-style-type: none"> • Adjust leveling crank spring pressure
DISC RIDGING ON LEFT SIDE (Tapered blade models when doubling back on left side)	
Insufficient overlap Rear gang set incorrectly	<ul style="list-style-type: none"> • Drive so as to overlap pass with approx. 2-blade coverage • Left rear blade should run in space between 2nd and 3rd blades of left front gang
GANGS PLUGGING	
Field too wet Gangs set at maximum angle Discing too deep in damp soil Discing with rows Scrapers adjusted improperly or worn	<ul style="list-style-type: none"> • Allow field to dry or disc shallow once to aid in drying • Reduce angle • Reduce penetration by raising disc • Disc diagonally • Adjust or replace scrapers as required

7 MAINTENANCE

Wheel offset disc harrow should be inspected **after the discing season**. Note excessively worn or broken parts and replace during the off-season. That way it is ready for use when needed.

After a **few hours of operation**, the gang bolts should be checked for tightness. To insure correct performance and avoid needless wear and breakage, these bolts must be tight at all times.

7.1 LUBRICATION

Your disc is equipped with prelubricated, greaseable gang bearings. No additional lubricant is required for start up. However, they should be greased daily when using the disc. When greasing, rotate the gangs to insure even distribution of grease in the bearing. Always use a hand powered pump as air or electric powered pumps provide too much pressure and result in ruptured seals. **Ruptured seals are not covered by warranty.** Use enough grease to fill each bearing.

The axle bearings, leveling crank pad eye and nut, and hydraulic pins require multi-purpose grease and should be greased **every 10 hours** of operation.

The wheel hub bearings should be checked for endplay and repacked with SAE multi-purpose grease **before operation and every 200 hours** thereafter. Should endplay occur in the hub, remove hubcap and cotter pin. Tighten the spindle nut until the bearing binds. Loosen spindle nut until bearing turns free with no endplay and reinstall cotter pin (nut may be tightened slightly for hole alignment). Replace hubcap.

7.2 GANG BOLTS

After **first 8 hours of use**, check gang bolts for correct tightness. Gang bolts nuts should be tightened to a pull of approximately 100 lbs. with a five-foot extension on the wrench for correct tightness.

8 PARTS LIST

8.1 G300 MAIN FRAME

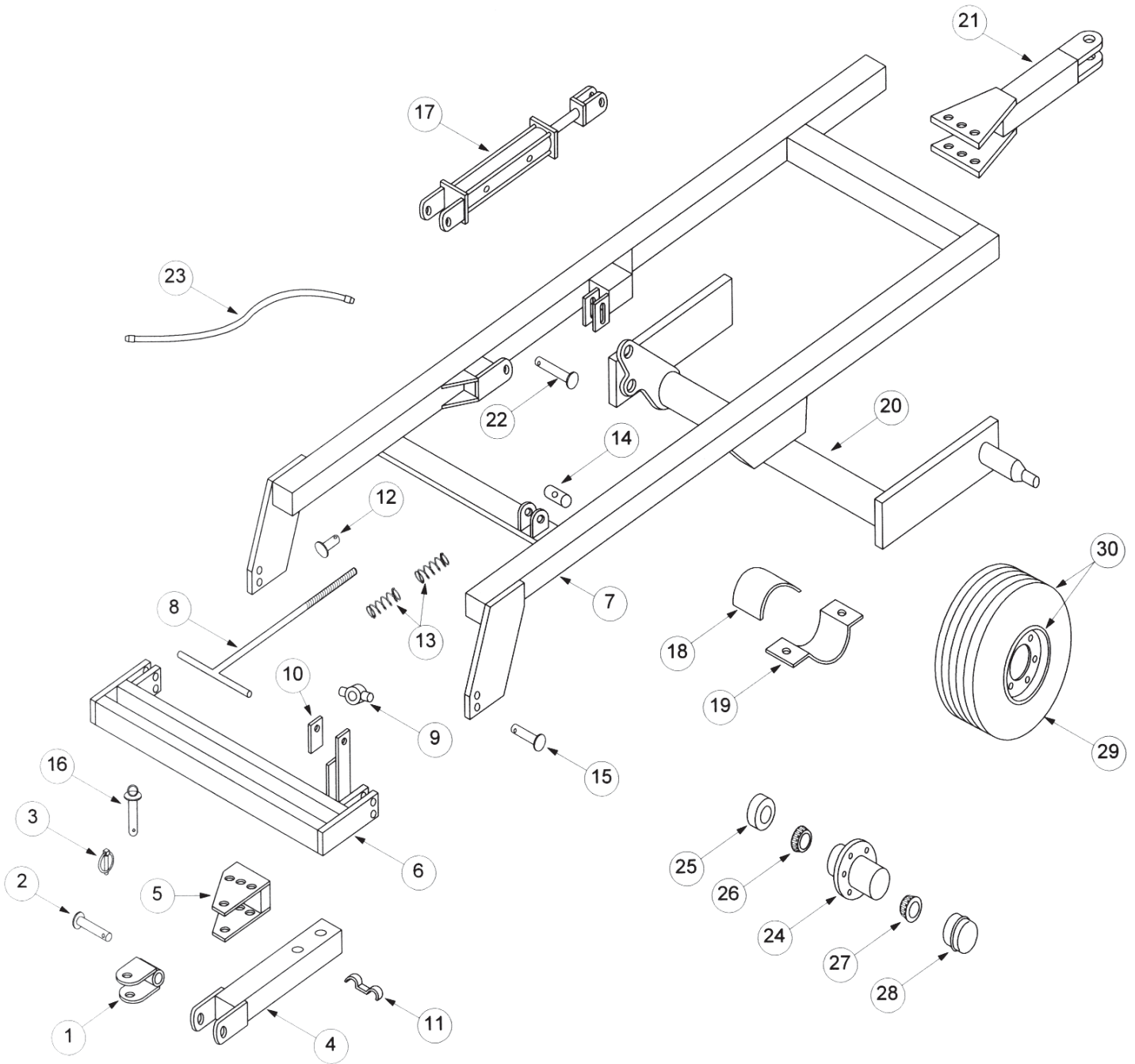

<u>REF.</u>	<u>PART NO.</u>	<u>DESCRIPTION</u>
1	WO6010-004	Clevis
2	WO6010-002	Clevis Pin
3	WO6010-003	Retainer Pin
4	730005	Tongue
5	730006	Tongue Mount (New Style)
6	730007	Tongue Drawbar 4'-6" thru 6'
6	730008	Tongue Drawbar 6'-9" thru 8'-3"
6	730009	Tongue Drawbar 9' thru 9'-9"
6	730010	Tongue Drawbar 10'-6" thru 12'
7	730001	Main Frame 4'-6" thru 6'
7	730002	Main Frame 6'-9" thru 8'-3"
7	730003	Main Frame 9' thru 9'-9"
7	730004	Main Frame 10'-6" thru 12'
8	WO6015	Leveling Crank
9	WO6073	Pad Eye
10	186004	Pad Eye Mount Plate
11	770108	Hose Clamp
12	WO6045	Single Spring Guide
13	WO6021	Leveling Spring
14	WO6078	Trunion Nut
15	WO6004A	Tongue Drawbar Pin
16	P1004	Tongue Mount Pin
17	RS112	Hydraulic Cylinder
18	74007	Wheel Axle Bushing
19	74006	Wheel Axle Cap
20	730013	Wheel Axle for 4'-6" thru 6' Frame
20	730014	Wheel Axle for 6'-9" thru 8'-3" Frame
20	730015	Wheel Axle for 9' thru 9'-9" Frame
20	730016	Wheel Axle for 10'-6" thru 12' Frame
21	WO6088	Rear Hitch
22	WO6083	Transport Pin - P1004
23	WO6020	Hydraulic Hose (2 pieces)
24	74026	Wheel Hub, Complete
25	74033	Hub Seal
26	74031	Inner Bearing
27	74032	Outer Bearing
28	74030	Hub Dust Cover
29	74025	Wheel
30	74027	Tire and Wheel

8.2 G300 GANG ASSEMBLY

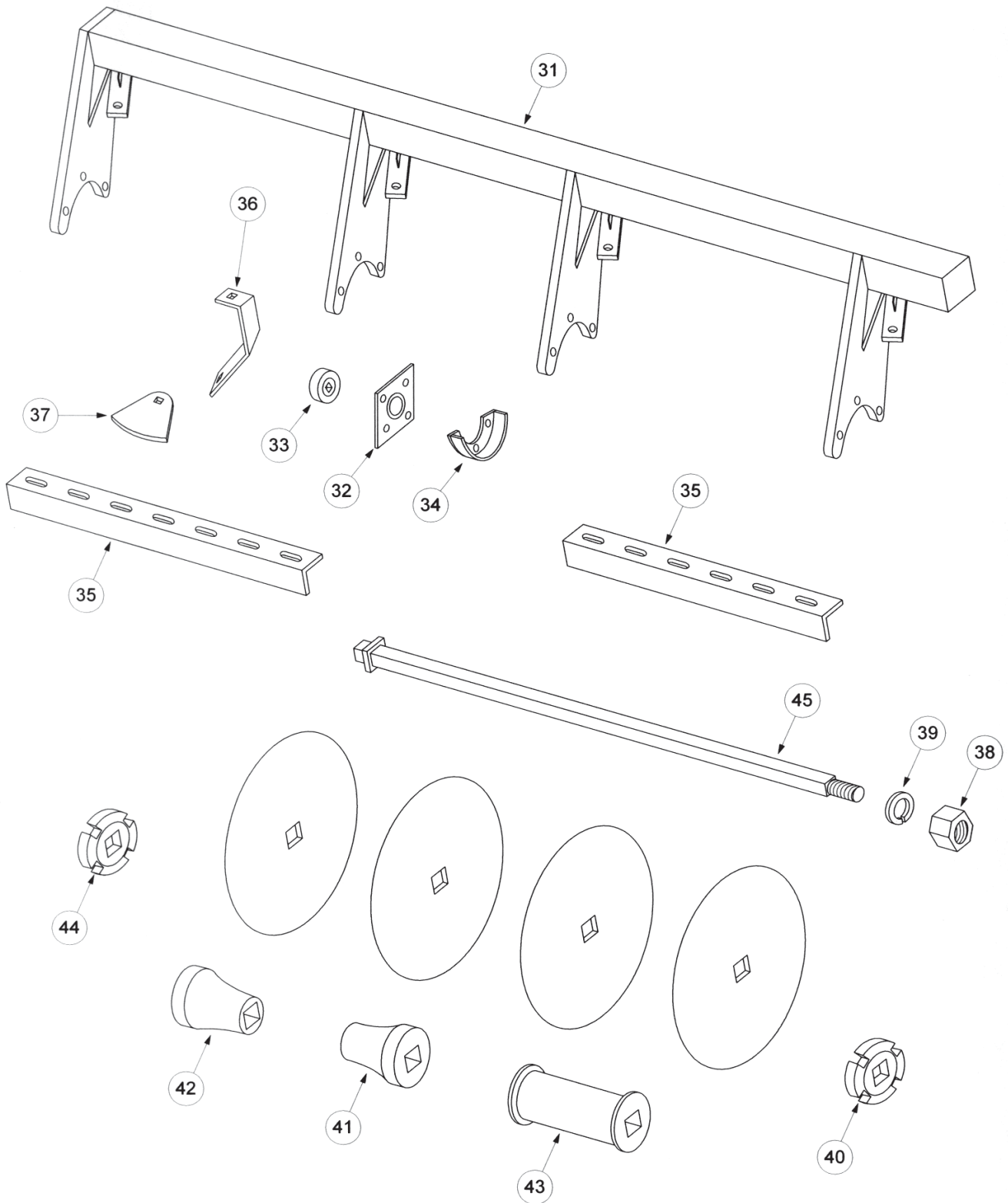

<u>REF.</u>	<u>PART NO.</u>	<u>DESCRIPTION</u>
31	730017	4'-6" Front Gang Beam - 6 Blade
31	730018	4'-6" Rear Gang Beam - 6 Blade
31	730019	5'-3" Front Gang Beam - 7 Blade
31	730020	5'-3" Rear Gang Beam - 7 Blade
31	730021	6' Front Gang Beam - 8 Blade
31	730022	6' Rear Gang Beam - 8 Blade
31	730023	6'-9" Front Gang Beam - 9 Blade
31	730024	6'-9" Rear Gang Beam - 9 Blade
31	730025	7'-6" Front Gang Beam - 10 Blade
31	730026	7'-6" Rear Gang Beam - 10 Blade
31	730027	8'-3" Front Gang Beam - 11 Blade
31	730028	8'-3" Rear Gang Beam - 11 Blade
31	730029	9' Front Gang Beam - 12 Blade
31	730030	9' Rear Gang Beam - 12 Blade
31	730031	9'-9" Front Gang Beam - 13 Blade
31	730032	9'-9" Rear Gang Beam - 13 Blade
31	730033	10'-6" Front Gang Beam - 14 Blade
31	730034	10'-6" Rear Gang Beam - 14 Blade
31	730035	12' Front Gang Beam - 16 Blade
31	730036	12' Rear Gang Beam - 16 Blade
32	185068	Bearing Flange - 80mm
33	185069	Bearing - Square Bore 1 1/8"
34	185030F	Bearing Dirt Shield - 1 1/8" - 80mm (Front)
34	185030R	Bearing Dirt Shield - 1 1/8" - 80mm (Rear)
35	74018F	4'-6" Scraper Mount Angle - Front
35	74018R	4'-6" Scraper Mount Angle - Rear
35	74029F	5'-3" Scraper Mount Angle - Front
35	74029R	5'-3" Scraper Mount Angle - Rear
35	WO6037F	6' Scraper Mount Angle - Front
35	WO6037R	6' Scraper Mount Angle - Rear
35	WO6037	6'-9" Scraper Mount Angle - Left Front
35	WO6038	6'-9" Scraper Mount Angle - Right Front
35	WO6039	6'-9" Scraper Mount Angle - Left Rear
35	WO6040	6'-9" Scraper Mount Angle - Right Rear
35	WO6037A	7'-6" Scraper Mount Angle - Left Front
35	WO6038A	7'-6" Scraper Mount Angle - Right Front
35	WO6039A	7'-6" Scraper Mount Angle - Left Rear
35	WO6040A	7'-6" Scraper Mount Angle - Right Rear
35	WO6037B	8'-3" Scraper Mount Angle - Left Front
35	WO6038B	8'-3" Scraper Mount Angle - Right Front
35	WO6039B	8'-3" Scraper Mount Angle - Left Rear
35	WO6040B	8'-3" Scraper Mount Angle - Right Rear
35	WO6037C	9' Scraper Mount Angle - Left Front
35	WO6038C	9' Scraper Mount Angle - Right Front
35	WO6039C	9' Scraper Mount Angle - Left Rear

<u>REF.</u>	<u>PART NO.</u>	<u>DESCRIPTION</u>
35	WO6040C	9' Scraper Mount Angle - Right Rear
35	WO6037D	9'-9" Scraper Mount Angle - Left Front
35	WO6038D	9'-9" Scraper Mount Angle - Right Front
35	WO6039D	9'-9" Scraper Mount Angle - Left Rear
35	WO6040D	9'-9" Scraper Mount Angle - Right Rear
35	WO6037E	10'-6" Scraper Mount Angle - Left Front
35	WO6038E	10'-6" Scraper Mount Angle - Right Front
35	WO6039E	10'-6" Scraper Mount Angle - Left Rear
35	WO6040E	10'-6" Scraper Mount Angle - Right Rear
35	WO6037F	12' Scraper Mount Angle - Left Front
35	WO6037G	12' Scraper Mount Angle - Center Front
35	WO6038F	12' Scraper Mount Angle - Right Front
35	WO6039F	12' Scraper Mount Angle - Left Rear
35	WO6039G	12' Scraper Mount Angle - Center Rear
35	WO6040F	12' Scraper Mount Angle - Right Rear
36	WO6041-L	Scraper Mount Arm - Left
36	WO6041-R	Scraper Mount Arm - Right
37	WO6042	Scraper Blade
38	200007-18	Axle Nut 1- ¹ / ₈ "
39	200005-18	Axle Lock Washer 1- ¹ / ₈ "
40	185006	Nut Washer 1- ¹ / ₈ "
41	185008	Half Spool Concave 1- ¹ / ₈ "
42	185007	Half Spool Convex 1- ¹ / ₈ "
43	185009	Full Spool 1- ¹ / ₈ "
44	185010	Axle Washer 1- ¹ / ₈ "
45	185011	4 Blade Axle 1- ¹ / ₈ "
45	185048	5 Blade Axle 1- ¹ / ₈ "
45	184001A	6 Blade Axle 1- ¹ / ₈ "
45	184001	7 blade Axle 1- ¹ / ₈ "
45	184002	8 Blade Axle 1- ¹ / ₈ "

9 LIMITED WARRANTY



GEARMORE, INC., warrants each new Gearmore product to be free from defects in material and workmanship for a period of twelve (12) months from date of purchase to the original purchaser. This warranty shall not apply to implements or parts that have been subject to misuse, negligence, accident, or that have been altered in any way.

Our obligation shall be limited to repairing or replacement of any part, provided that such part is returned within thirty (30) days from date of failure to Gearmore through the dealer from whom the purchase was made, transportation charges prepaid.

This warranty shall not be interpreted to render us liable for injury or damages of any kind or nature, direct, consequential or contingent, to person or property. This warranty does not extend to loss of crops, loss because of delay in harvesting or any other expenses, for any other reasons.

Gearmore in no way warrants engines, tires, or other trade accessories, since these items are warranted separately by these respective manufacturers.

Gearmore reserves the right to make improvements in design or changes in specification at any time, without incurring any obligations to owners or units previously sold.

GEARMORE, INC.
13477 Benson Ave.
Chino, CA 91710

Always refer to and heed machine operating warning decals on machine.

The serial number of this product is stored in our computer database, thus submitting a warranty registration card is not required.