

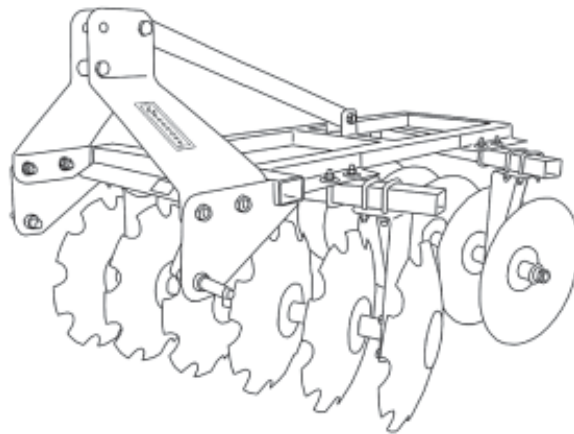

OFFSET DISCS



**Operation, Service
& Parts Manual For
Models: C1218, C1418,
C1618, D1818, & D2018**

June 2006

TABLE OF CONTENTS

SECTION	DESCRIPTION	PAGE
1	Introduction	1
1.1	Serial Number Location	1
2	Safety	2
2.1	General Safety	3
2.2	Equipment Safety Guidelines	4
2.3	Safety Training	5
2.4	Safety Signs	5
2.5	Preparation	6
2.6	Operating Safety	7
2.7	Transport Safety	8
2.8	Maintenance Safety	8
2.9	Hydraulic Safety	9
2.10	Storage Safety	9
3	Operation	10
3.1	To the New Operator or Owner	10
3.2	Machine Components	11
3.3	Pre-Operation Checklist	13
3.4	Preparation of Tractor	13
3.5	Field Operation	14
3.6	Disc Angle Adjustment	15
3.7	Maintenance	15
3.8	Transporting	16
3.9	Storage	16
4	Trouble Shooting	17
5	Assembly	18
6	Specifications	19
6.1	Mechanical	19
6.2	Bolt Torque	19
7	Limited Warranty	20

1 INTRODUCTION

Congratulations on your choice of Offset Discs.

Safe, efficient and trouble free operation of your Offset Discs requires that you and anyone else who will be operating or maintaining the machine, read and understand the Safety, Operation, Maintenance and Troubleshooting information contained within the Operator's Manual.

This manual covers the Offset Disc Models T1618, T2018 & T2418. Differences are explained where appropriate. Use the Table of Contents as a guide to locate required information.

Keep this manual handy for frequent reference and to pass on to new operators or owners. Call your Gearmore dealer or distributor if you need assistance, information or additional copies of the manuals.

OPERATOR ORIENTATION - The directions left, right, front and rear, as mentioned throughout this manual, are as seen from the driver's seat and facing in the direction of travel.

1.1 SERIAL NUMBER LOCATION

Always give your dealer the serial number of your Offset Disc when ordering parts or requesting service or other information.

The serial number plate is located where indicated. Please mark the number in the space provided for easy reference.

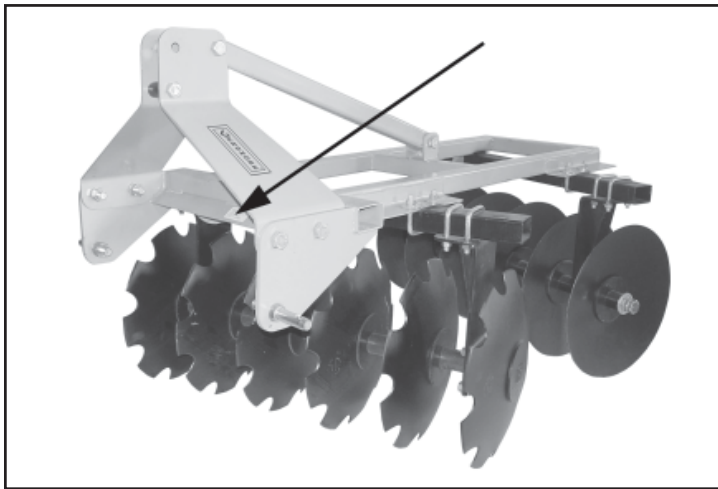

DATE OF PURCHASE: _____

MODEL NUMBER: _____

SERIAL NUMBER: _____

2 SAFETY

SAFETY ALERT SYMBOL

This Safety Alert symbol means **ATTENTION! BECOME ALERT! YOUR SAFETY IS INVOLVED!**

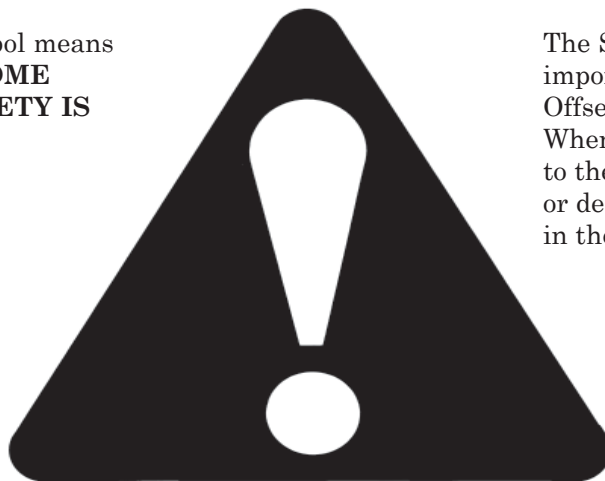

The Safety Alert symbol identifies important safety messages on the Offset Discs and in the manual. When you see this symbol, be alert to the possibility of personal injury or death. Follow the instructions in the safety message.

Why is SAFETY important to you?

3 Big Reasons

Accidents Disable and Kill
Accidents Cost
Accidents Can Be Avoided

SIGNAL WORDS:

Note the use of the signal words **DANGER**, **WARNING** and **CAUTION** with the safety messages. The appropriate signal word for each message has been selected using the following guide-lines:

SI NO LEE INGLES, PIDA AYUDA A AIGUIEN QUE SI LO LEA PARA QUE LE TRADUZCA LAS MIDIDAS DE SEGURIDAD.

DANGER - Indicates an imminently hazardous situation that, if not avoided, will result in death or serious injury. This signal word is to be limited to the most extreme situations typically for machine components which, for functional purposes, cannot be guarded.

WARNING - Indicates a potentially hazardous situation that, if not avoided, could result in death or serious injury, and includes hazards that are exposed when guards are removed. It may also be used to alert against unsafe practices.

CAUTION - Indicates a potentially hazardous situation that, if not avoided, may result in minor or moderate injury. It may also be used to alert against unsafe practices.

If you have any questions not answered in this manual or require additional copies or the manual is damaged, please contact your dealer.

2.1 GENERAL SAFETY

YOU are responsible for the **SAFE** operation and maintenance of your Offset Disc. **YOU** must ensure that you and anyone else who is going to operate, maintain or work around the Disc be familiar with the operating and maintenance procedures and related **SAFETY** information contained in this manual. This manual will take you step-by-step through your working day and alerts you to all good safety practices that should be adhered to while operating the Disc.

Remember, **YOU** are the key to safety. Good safety practices not only protect you, but also the people around you. Make these practices a working part of your safety program. Be certain that **EVERYONE** operating this equipment is familiar with the recommended operating and maintenance procedures and follows all the safety precautions. Most accidents can be prevented. Do not risk injury or death by ignoring good safety practices.

- Disc owners must give operating instructions to operators or employees before allowing them to operate the machine, and at least annually there after per OSHA (Occupational Safety and Health Administration) regulation 1928.57.
- The most important safety feature on this equipment is a **SAFE** operator. It is the operator's responsibility to read and understand **ALL** Safety and Operating instructions in the manual and to follow these. Most accidents can be avoided.
- A person who has not read and understood all operating and safety instructions is not qualified to operate the machine. An untrained operator exposes himself and bystanders to possible serious injury or death.
- **DO NOT** modify the equipment in any way. Unauthorized modification may impair the function and/or safety and could affect the life of the equipment.

1. Read and understand the Operator's Manual and all safety signs before operating, maintaining or adjusting the Offset Disc.



2. Have a first-aid kit available for use should the need arise and know how to use it.



3. Have a fire extinguisher available for use should the need arise and know how to use it.

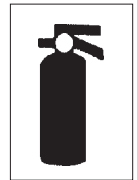

4. Wear appropriate protective gear. This list includes but is not limited to:

- A hard hat
- Protective shoes with slip resistant soles
- Protective goggles, glasses or face shield
- Heavy gloves
- Protective clothing



5. **NEVER** allow children to operate tractor and Disc or other power equipment.

6. **DO NOT** allow riders.

7. Wear suitable ear protection for prolonged exposure to excessive noise.



8. Lower Offset Disc to the ground, set park brake, remove ignition key and wait for all moving parts to stop before servicing, adjusting and repairing.

9. Clear the area of people, especially small children, before starting.

10. Review safety related items annually with all personnel who will be operating or maintaining the Offset Disc.

2.2 EQUIPMENT SAFETY GUIDELINES

Safety of the operator and bystanders is one of the main concerns in designing and developing a machine. However, every year many accidents occur which could have been avoided by a few seconds of thought and a more careful approach to handling equipment. You, the operator, can avoid many accidents by observing the following precautions in this section. To avoid personal injury or death, study the following precautions and insist those working with you, or for you, follow them.

- In order to provide a better view, certain photographs or illustrations in this manual may show an assembly with a safety shield removed. However, equipment should **never** be operated in this condition. Keep all shields in place. If shield removal becomes necessary for repairs, replace the shield prior to use.
- Replace any safety sign or instruction sign that is not readable or is missing. Location of such safety signs is indicated in this manual.
- **NEVER** use alcoholic beverages or drugs which can hinder alertness or coordination while operating this equipment. Consult your doctor about operating this machine while taking prescription medications.
- **Under no circumstances should young children be allowed to work with this equipment. Do not allow persons to operate or assemble this unit until they have read this manual and have developed a thorough understanding of the safety precautions and of how it works.** Review the safety instructions with all users annually.

- This equipment is dangerous to children and persons unfamiliar with its operation. The operator should be a responsible, properly trained and physically able person familiar with farm machinery and trained in this equipment's operations. If the elderly are assisting with farm work, their physical limitations need to be recognized and accommodated.
- Use a tractor equipped with a Roll Over Protective Structure (ROPS) and a seat belt.
- **NEVER** exceed the limits of a piece of machinery. If its ability to do a job, or to do so safely, is in question - **DON'T TRY IT.**
- Do not modify the equipment in any way. Unauthorized modification may impair the function and/or safety and could affect the life of the equipment.

In addition to the design and configuration of this implement, including Safety Signs and Safety Equipment, hazard control and accident prevention are dependent upon the awareness, concern, prudence and proper training of personnel involved in the operation, transport, maintenance and storage of the machine. Refer also to Safety Messages and operation instruction in each of the appropriate sections of the tractor and machine manuals. Pay close attention to the Safety Signs affixed to the tractor and the machine.

Think SAFETY! Work SAFELY!

2.3 SAFETY TRAINING

Safety is a primary concern in the design and manufacture of our products. Unfortunately, our efforts to provide safe equipment can be wiped out by a single careless act of an operator or bystander.

In addition to the design and configuration of equipment, hazard control and accident prevention are dependent upon the awareness, concern, prudence and proper training of personnel involved in the operation, transport, maintenance and storage of this equipment.

It has been said, "***The best safety feature is an informed, careful operator.***" We ask you to be that kind of an operator. It is the operator's responsibility to read and understand ALL Safety and Operating instructions in the manual and to follow these. Accidents can be avoided.



Working with unfamiliar equipment can lead to careless injuries. Read this manual, and the manual for your tractor, before assembly or operating, to acquaint yourself with the machines. If this machine is used by any person other than yourself, or is loaned or rented, it is the machine owner's responsibility to make certain that the operator, prior to operating:

- a. Reads and understands the operator's manuals.
- b. Is instructed in safe and proper use.

Know your controls and how to stop tractor, engine and machine quickly in an emergency. Read this manual and the one provided with your tractor.

Train all new personnel and review instructions frequently with existing workers. Be certain only a properly trained and physically able person will operate the machinery. A person who has not read and understood all operating and safety instructions is not qualified to operate the machine. An untrained operator exposes himself and bystanders to possible serious injury or death. If the elderly are assisting with farm work, their physical limitations need to be recognized and accommodated.

2.4 SAFETY SIGNS

1. Keep safety signs clean and legible at all times.
2. Replace safety signs that are missing or have become illegible.
3. Replaced parts that displayed a safety sign should also display the current sign.
4. Safety signs are available from your authorized dealer or from Gearmore.

How To Install Safety Signs:

- Be sure that the installation area is clean and dry.
- Be sure temperature is above 50° F (10° C).
- Determine exact position before you remove the backing paper. (*See Section 3*)
- Remove the smallest portion of the split backing paper.
- Align the sign over the specified area and carefully press the small portion with the exposed sticky backing in place.
- Slowly peel back the remaining paper and carefully smooth the remaining portion of the sign in place.
- Small air pockets can be pierced with a pin and smoothed out using the piece of sign backing paper.

2.5 PREPARATION

1. Never operate the tractor and machine until you have read and completely understand this manual, the Tractor Operator's Manual and each of the Safety Messages found on the safety signs on the tractor and machine.

2. Personal protection equipment, including hard hat, safety glasses, safety shoes and gloves are recommended during assembly, installation, operation, adjustment, maintaining, repairing, removal or moving the implement. **DO NOT** allow long hair, loose fitting clothing or jewelry to be around equipment.

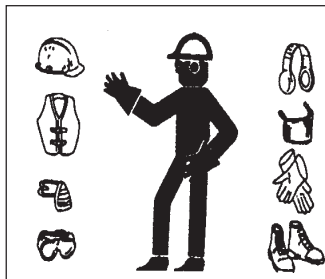

3. **PROLONGED EXPOSURE TO LOUD NOISE MAY CAUSE PERMANENT HEARING LOSS!**

Tractors with or without equipment attached can often be noisy enough to cause permanent, partial hearing loss. We recommend that you wear hearing protection on a full-time basis if the noise in the Operator's position exceeds 80db. Noise over 85db on a long-term basis can cause severe hearing loss. Noise over 90db adjacent to the Operator over a long-term basis may cause permanent, total hearing loss. **NOTE:** Hearing loss from loud noise (from tractors, chain saws, radios, and other such sources close to the ear) is cumulative over a lifetime without hope of natural recovery.

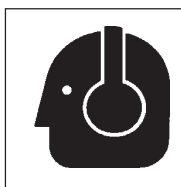

4. Operate the machine only with a tractor equipped with an approved Roll-Over Protective Structure (ROPS). Always wear your seat belt. Serious injury or even death could result from falling off the tractor --- particularly during a turn-over when the operator could be pinned under the ROPS or the tractor.
- 
5. Clear working area of stones, branches or hidden obstacles that might be hooked or snagged, causing injury or damage.
 6. Keep disc away from overhead power lines. Electrocution can occur without direct contact with an overhead power line.
 7. Operate only in daylight or good artificial light.
 8. Be sure machine is properly mounted, adjusted and in good operating condition.
 9. Before starting, give the machine a "once over" for any loose bolts, worn parts, cracks, leaks, frayed hoses and make necessary repairs. Always follow maintenance instructions.
 10. Ensure that all safety shielding and safety signs are properly installed and in good condition.
 11. Use caution when operating the tractor on uneven terrain.
 12. Move wheels or tires to their widest position for maximum stability.
 13. Decrease speed when making turns.
 14. Use front and rear wheel weights as required.
 15. Add sufficient amount of weight to front end of tractor to prevent wheels from coming off the ground when starting suddenly with a load.

2.6 OPERATING SAFETY

Please remember it is important that you read and heed the safety signs on the tractor and disc. Clean or replace all safety signs if they cannot be clearly read and understood. They are there for your safety, as well as the safety of others. The safe use of this machine is strictly up to you, the operator.

All things with moving parts are potentially hazardous. There is no substitute for a cautious, safe-minded operator who recognizes potential hazards and follows reasonable safety practices. The manufacturer has designed these Discs to be used with all its safety equipment properly attached to minimize the chance of accidents. Study this manual to make sure you have all safety equipment attached.

Practice raising and lowering the disc when learning to operate the Offset disc. Become familiar with controls before operating.

If a safety shield or guard is removed for any reason, it must be replaced before the machine is again operated.

Always operate disc with hitch hydraulic control lever in lowered "float" position.

Do not operate near the edge of drop-offs or banks.

Do not operate at an angle on steep slopes. Drive up or down but not across. Always lift disc before turning at ends of field.

Make allowances for increased length and weight of tractor during operation and moving.

Remove all sticks, stones, roots and wires from working area before starting. Take care not to contact overhead obstructions during operation.

Never operate controls from the ground. Operate only from the operators seat to prevent unexpected movement that can lead to crushing between frame members.

Start operation at a slower comfortable speed; increase tractor speed as clods reduce size.

Keep disc away from overhead power lines. Electrocutation can occur without direct contact with an overhead power line.

Never carry, lift or move people on disc. Do not use machine as a work platform.

Always use two people to handle heavy, unwieldy components during assembly, installation, removal or moving.

Never place any part of your body where it would be in danger if movement should occur during assembly, installation, operation, maintaining, repairing, removal or moving.

Do not walk or work under a raised machine or attachment unless it is securely blocked or held in position. Do not depend on the tractor hydraulic system to hold the machine or attachment in place.

Never use alcoholic beverages or drugs, which can hinder alertness or coordination, while operating this equipment. Consult your doctor about operating this machine while taking prescription medications.

Do not allow riders on the machine or tractor at any time. There is no safe place for any riders.

Do not go under raised disc. Keep others away.

Add sufficient amount of weight to front end of tractor to prevent wheels from coming off the ground when starting suddenly with a load.

Always remove the key when leaving the tractor unattended.

Never allow disc to be left in the "up" position when unattended.

Before you operate the machine, check over all pins, bolts and connections to be sure all are securely in place. Replace any damaged or worn parts immediately.

Review safety instructions annually.

2.7 TRANSPORT SAFETY

1. Comply with state and local laws governing highway safety and movement of farm machinery on public roads.
2. The use of flashing amber lights is acceptable in most localities. However, some localities prohibit their use. Local laws should be checked for all highway lighting and marking requirements.
3. At all times, when driving the tractor and equipment on the road or highway under 20 mph (32 kph) use flashing amber warning lights and a slow moving vehicle (SMV) identification emblem. Do not exceed 20 mph (32 kph). Reduce speed on rough roads and surfaces.
4. Keep tractor in gear to provide engine braking when going downhill. Do not coast.
5. Plan your route to avoid heavy traffic.
6. Keep brake pedals latched together at all times.
7. Do not drink and drive.
8. Be a safe and courteous driver. Always yield to oncoming traffic in all situations, including narrow bridges, intersections, etc. Watch for traffic when operating near or crossing roadways.
9. Turn into curves or go up or down hills only at a low speed and at a gradual steering angle. Make certain that at least 20% of the tractor's weight is on the front wheels to maintain safe steering. Slow down on rough or uneven surfaces.
10. Never allow riders on either tractor or machine. Riders may obstruct the operator's view. They could also be struck by foreign objects or thrown from the machine.



2.8 MAINTENANCE SAFETY

1. Good maintenance is your responsibility. Poor maintenance is an invitation to trouble.
2. Follow good shop practices.
 - Keep service area clean and dry.
 - Be sure electrical outlets and tools are properly grounded.
 - Use adequate light for the job at hand.
3. Make sure there is plenty of ventilation. Never operate the engine in a closed building. The exhaust fumes may cause asphyxiation.
4. Before working on this machine, shut off the engine, set the brakes and remove the ignition key.
5. Never work under equipment unless it is blocked securely.
6. Use personal protection devices such as eye, hand and hearing protectors, when performing any service or maintenance work.
7. Where replacement parts are necessary for periodic maintenance and servicing, genuine factory replacement parts **must** be used to restore your equipment to original specifications. The manufacturer will not be responsible for injuries or damages caused by use of unapproved parts and/or accessories.
8. A fire extinguisher and first aid kit should be kept readily accessible while performing maintenance on this equipment
9. Periodically tighten all bolts, nuts and screws and check that all cotter pins are properly installed to ensure unit is in a safe condition.
10. When completing a maintenance or service function, make sure all safety shields and devices are installed before placing unit in service.

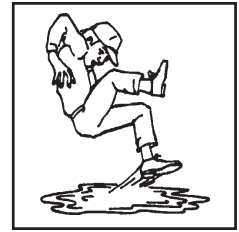

2.9 HYDRAULIC SAFETY

- Make sure that all the components in the hydraulic system are kept in good condition and are clean.
- Replace any worn, cut, abraded, flattened or crimped hoses and metal lines.
- Relieve pressure before working on hydraulic system.
- Do not attempt any makeshift repairs to the hydraulic lines, fittings or hoses by using tapes, clamps or cements. The hydraulic system operates under extremely high pressure. Such repairs will fail suddenly and create a hazardous and unsafe condition.
- Wear proper hand and eye protection when searching for a high pressure hydraulic leak. Use a piece of wood or cardboard as a backstop instead of hands to isolate and identify a leak.
- If injured by a concentrated high pressure stream of hydraulic fluid, seek medical attention immediately. Serious infection or toxic reaction can develop from hydraulic fluid piercing the skin surface.
- Before applying pressure to the system, make sure all components are tight and that lines, hoses and couplings are not damaged.
- When disconnecting hydraulic lines, shut off hydraulic supply and relieve hydraulic pressure.

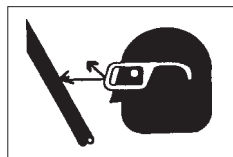

2.10 STORAGE SAFETY

1. Store the unit in an area away from human activity
2. Do not permit children to play on or around the stored machine.
3. Store the unit in a dry, level area. Support the frame with planks or blocks if required.

SAFETY RECAP

The manufacturer follows the general Safety Standards specified by the American Society of Agricultural Engineers (ASAE) and the Occupational Safety and Health Administration (OSHA). Anyone who will be operating and/or maintaining the Offset Disc must read and clearly understand ALL Safety, Operating and Maintenance information presented in this manual.

Do not operate or allow anyone else to operate this equipment until such information has been reviewed. Annually review this information before the season start-up.

Make these periodic reviews of SAFETY and OPERATION a standard practice for all of your equipment. We feel that an untrained operator is unqualified to operate this machine.

Think SAFETY! Work SAFELY!

3 OPERATION



OPERATING SAFETY

1. Read Operator's Manual.
2. Lower disc to the ground, stop engine, set park brake, remove ignition key and wait for all moving parts to stop before servicing, adjusting and repairing.
3. Do not carry people on disc or frame.
4. Add sufficient weight to front end of tractor to prevent wheels from coming off the ground when starting suddenly with a load.
5. Stay away from overhead power lines. Electrocutation can occur without direct contact.
6. Use caution when operating the tractor on uneven terrain. Decrease speed when making turns. Use front and rear wheel weights as required.
7. Use only with a unit with ROPS and a seat belt.
8. Never allow disc to be left in the "up" position when unattended.
9. Always remove the key when leaving the tractor unattended.
10. Review safety instructions.

3.1 TO THE NEW OPERATOR OR OWNER

Disc should run level when 3-point hitch is pre-adjusted as recommended and disc blades are running between 3" - 5" deep. Depth of cut will vary depending on soil type, moisture content and weight of implement. Start operation at a slower comfortable speed; increase tractor speed as clods reduce size. The types of soil, moisture and weight on harrow will determine how many times you will have to go back and forth to get the kind of seed bed desired. For harder or dryer soils, additional weight may be added to improve penetration. Always operate disc with hitch hydraulic control lever in lowered "float" position. Ridging, sometimes caused by rear outer discs, can be reduced or eliminated by changing tractor speed, shortening upper link, or a combination of both. Always lift disc before turning at ends of field.

It is the responsibility of the owner or operator to read this manual and to train all other operators before they start working with the machine. Follow all safety instructions exactly. Safety is everyone's business. By following recommended procedures, a safe working environment is provided for the operator, bystanders and the area around the worksite. Untrained operators are not qualified to operate the machine.

Many features incorporated into this machine are the result of suggestions made by customers like you. Read this manual carefully to learn how to operate the machine safely and how to set it to provide maximum field efficiency. By following the operating instructions in conjunction with a good maintenance program, your Offset Disc will provide many years of trouble free service.

3.2 MACHINE COMPONENTS

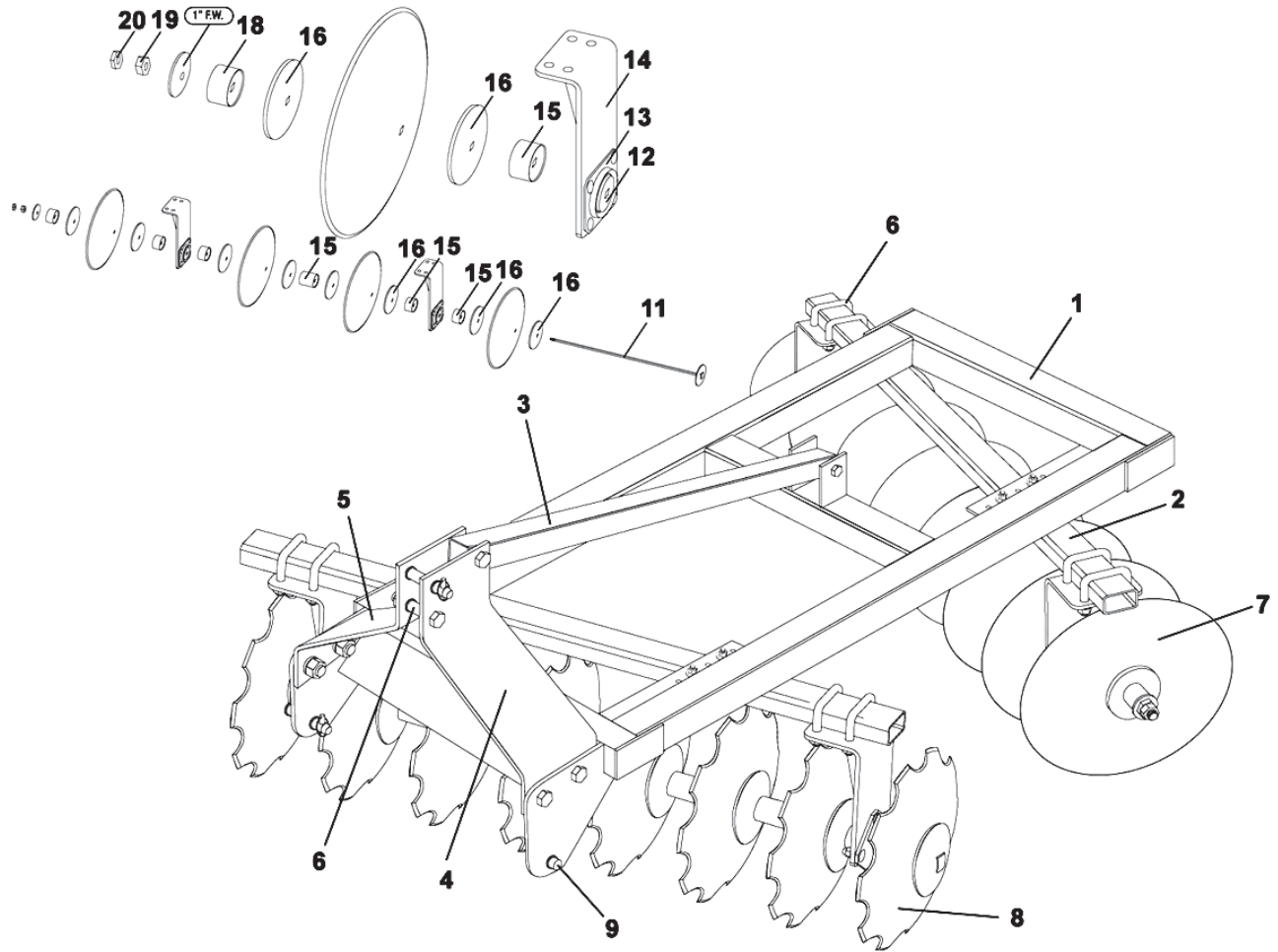

<u>REF. NO.</u>	<u>QTY.</u>	<u>PART NO.</u>	<u>DESCRIPTION</u>
1	1	800320	Disc Frame (C1218 & C1418)
1	1	800321	Disc Frame (C1618)
1	1	810205	Disc Frame (D1818 & D2018)
2	2	800110	Beam 37" (C1218 & C1418)
2	2	800143	Beam 52" (C1618)
2	2	810220	Beam 56" (D1818 & D2018)
3	1	521102	Top Brace 2 x 2 x 32" (C1218 & C1418)
3	1	824104	Top Brace 2 x 2 x 37" (C1618)
3	1	800338	Top Brace 2 x 2 x 40" (D1818 & D2018)
4	1	800336	Front Hitch ASAE LH 1/4" (C1218, C1418 & C1618)
4	1	830542	Front Hitch LH 3/8" (D1818 & D2018)
5	1	800337	Front Hitch ASAE RH 1/4" (C1218, C1418 & C1618)
5	1	830543	Front Hitch RH 3/8" (D1818 & D2018)
6	10	800116	U-Bolt 1/2 x 3 x 3 (C1218, C1418 & C1618)
6	10	830529	U-Bolt 5/8 x 4 1/4 x 3 1/2 (D1818 & D2018)
7	As Req'd	800136	Disc Blade 18" Plain
8	As Req'd	800139	Disc Blade 18" Notched

<u>REF. NO.</u>	<u>QTY.</u>	<u>PART NO.</u>	<u>DESCRIPTION</u>
9	2	500106	Hitch Pin Cat. 1
10	As Req'd	830544	ASAE Bushing $3/4$ "IDx1 $1/4$ "ODx1 $15/16$ " (Not Shown)
11	2	800129	Axle 6-Blade 41 $1/2$ " (C1218)
11	2	800132	Axle 7-Blade 49 $1/2$ " (C1418)
11	2	800134	Axle 8-Blade 56 $1/2$ " (C1618)
11	2	810129	Axle 9-Blade 64" (D1818)
11	2	810128	Axle 10-Blade 71 $1/2$ " (D2018)
12	4	W208PPB5	Bearing
13	8	800119	Flange
	16	800121	Bolt $1/2$ x 1 $1/4$ C.B. (C1218, C1418 & C1618)
	32	800121	Bolt $1/2$ x 1 $1/4$ C.B. (D1818 & D2018)
14	4	800214	Bearing Hanger 4-Hole (C1218, C1418 & C1618)
14	4	810215	Bearing Hanger 4-Hole (D1818 & D2018)
15	8	800325	Spool 2 $11/16$ "
16	As Req'd	800327	Spacer Washer
17	As Req'd	800326	Spool 6 $13/16$ "
18	2	800328	Spool (End Cap)
19	2	800150	Reg 1" Nut
20	2	800151	Jam Nut 1"

BOLT PACK (C1218, C1418 & C1618)

Containing:

3	ea.	$3/4$ x 4 Hex Head Bolts
4	ea.	$3/4$ x 2 Hex Head Bolts
20	ea.	$1/2$ Hex Nuts
7	ea.	$3/4$ Hex Nuts
20	ea.	$1/2$ Lock Washers
7	ea.	$3/4$ Lock Washers
4	ea.	$1/2$ Flat Washers

BOLT PACK (D1818 & D2018)

Containing:

3	ea.	$3/4$ x 4 Hex Head Bolts
4	ea.	$3/4$ x 2 Hex Head Bolts
10	ea.	$5/8$ Hex Nuts
7	ea.	$3/4$ Hex Nuts
10	ea.	$5/8$ Lock Washers
7	ea.	$3/4$ Lock Washers
4	ea.	$5/8$ Flat Washers

3.3 PRE-OPERATION CHECKLIST

Prior to use, it is recommended that the following mechanical items be checked:

A. Daily Operation Checks:

1. Check all nuts, bolts and other fasteners. Tighten to their specified torque level.
2. Clean the unit of dirt and trash to minimize rusting and wear.
3. Inspect all bearings for wear. Replace any worn out bearings.
4. Replace any decals that are worn or damaged.

IMPORTANT:

Torque disc gang axle nuts to 250 ft. lbs. after the first initial 5 hours of operation. Failure to tighten the axle nuts may result in the nut becoming loose or lost resulting in possible damage to the axle and/or disc gang.

Efficient and safe operation of the Offset Disc requires that each operator reads and understands the operating procedures and all related safety precautions outlined in this section. A pre-operation checklist is provided for the operator. It is important for both the personal safety and maintaining the good mechanical condition of the Offset Disc that this checklist is followed.

Before operating the machine and each time thereafter, the following areas should be checked off:

- ✓ Use only an Agricultural tractor of the appropriate horsepower on the machine.
- ✓ Check that the Disc is properly attached to the tractor.
- ✓ Be sure extra weights are mounted on the front end of the tractor to prevent wheels from coming off the ground when starting suddenly with a load.
- ✓ Check all parts for damage. Repair or replace as required.
- ✓ Check for entangled material. Remove this material.

3.4 PREPARATION OF TRACTOR

With the hitch in the lowered position, adjust lower link arms (**Ref. 1**) until lower link ball ends (**Ref. 2**) are approximately 10" from ground.

Attach stabilizer chains (**Ref. 3**) to lower pin position at tractor. **DO NOT TIGHTEN**. Attach disc to lower links (**Ref. 1**) of hitch (inside pins for Category "0", outside pins for Category "I") and secure with spring pins.

Connect upper link (**Ref. 4**) of tractor hitch to the mounting holes on upper part of main frame (use lower holes for Category "0", top holes for Category "I"). Secure with hitch pin and spring pin.

When using a offset disc, place the hitch in "Float" and adjust upper link (**Ref. 4**) so that the front and rear gangs are on the ground.

Raise disc with lift and adjust stabilizer chains (**Ref. 3**) to prevent side sway in the transport position.

Be sure you read and understand the Operator's Instruction Manual.

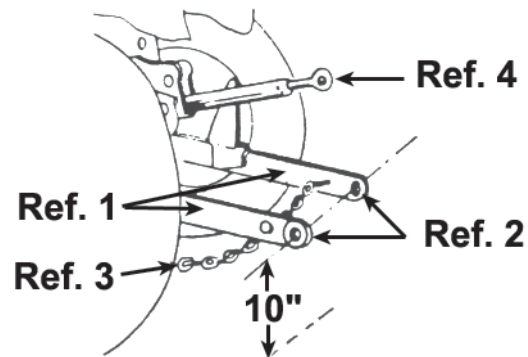

3.5 FIELD OPERATION



OPERATING SAFETY

1. Read Operator's Manual.
2. Lower offset disc to the ground, stop engine, set park brake, remove ignition key and wait for all moving parts to stop before servicing, adjusting and repairing.
3. Do not carry people on disc or frame.
4. Add weight to front of tractor to prevent wheels from coming off the ground.
5. Stay away from overhead power lines. Electrocution can occur without direct contact.
6. Use caution when operating on uneven terrain. Decrease speed when making turns.
7. Use only with a unit with ROPS and a seat belt.
8. Never allow disc to be left in the "up" position when unattended.
9. Give complete undivided attention to the job at hand.
10. Do not go under raised implement. Keep others away.

The disc should run level when 3-point hitch is pre-adjusted as recommended and disc blades are running between 3" to 5" deep. Depth of cut will vary depending on soil type, moisture content and weight of implement. Start working operation at a slower comfortable speed; increase tractor speed as clods reduce size. The types of soil, moisture and weight on disc will determine how many times you will have to go back and forth to get the kind of seed bed desired. For harder or dryer soils, additional weight may be added to improve penetration. Always operate disc with hitch hydraulic control lever in lowered "float" position. Ridging, sometimes caused by rear outer discs, can be reduced or eliminated by changing tractor speed, shortening upper link, or a combination of both. Always lift disc before turning at ends of field.

Each operator should review this section of the manual at the start of the season and as often as required to be familiar with the machine.



CAUTION!

Be careful when working with Disc blades, as the edges are sharp. Wear gloves when working around disc blades.

1. After initial adjustments have been made and tractor is hooked up to Disc, you are ready to start discing.

2. Lower Disc to ground and start moving forward. Your travel speed will be determined by soil conditions. You may find you want more or less angle on the discs to do the job. Refer to Disc Gang Angle Adjustment on page 15.
3. When turning, always lift implement up out of ground.



CAUTION!

Damage to the disc can occur if it is not lifted out of the ground before turning.

4. Do not disc in reverse (travel backwards). The disc is designed for working the soil while traveling forward only. Damage to the harrow may occur. Recommended procedure for corners or tight places is:
 - a. Lift unit up
 - b. Back up into corner or other tight areas
 - c. Lower disc to ground and proceed with discing going forward
5. Do not cross a ditch at a 90° angle (straight on). Damage to the disc and/or tractor may occur while crossing at a 90° angle. Always cross a ditch on a diagonal.

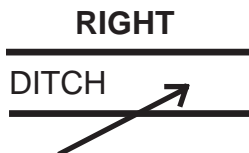

RIGHT

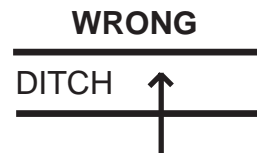

WRONG

3.6 DISC ANGLE ADJUSTMENT

Your Gearmore Disc has 3 angle settings. If you are using your Disc in loose soil and it is digging too deep, reduce the gang angle cut. If your disc is not digging deep enough, increase the gang angle cut.

IMPORTANT:

Always turn tractor key off and remove key before performing any maintenance or adjustments on Disc.

To adjust the gang angle cut, raise the Disc a few inches off the ground and block it up. Loosen the hex head bolts in each disc gang mounting bar, where it mounts to the main frame. Remove the bolts from the bar and move the gang to the front or back. Re-install the bolts and tighten.

NOTE:

The more angle you have the more aggressive the cut will be and the more horsepower will be required to pull your unit.

For better ground finish, angle the rear gangs at a lesser angle than the front gangs.

NOTE:

The rear discs should be centered between the front discs for optimum performance.

3.7 MAINTENANCE

Proper service and adjustment is the key to long life for any implement. With careful systematic inspections, you can avoid many costly repairs and downtime.

Torque all nuts to the torque value listed on page 20 after the first initial 5 hours of field operation.

IMPORTANT:

Torque disc gang axle nuts to 250 ft. lbs. after the first initial 5 hours of operation. Failure to tighten the axle nuts may result in the nut becoming loose or lost resulting in possible damage to the axle and/or disc gang.

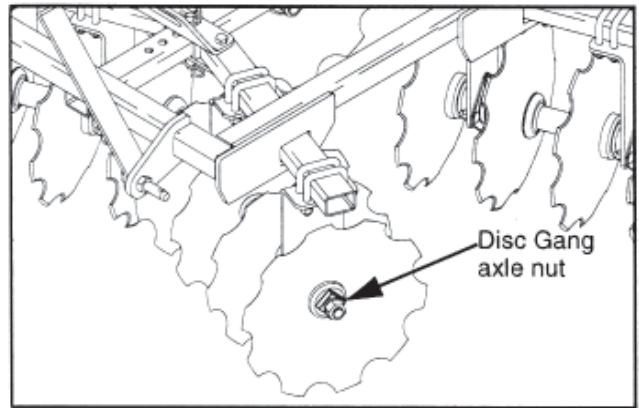

LUBRICATION

There are no parts on the disc that require lubrication.

Bearings are sealed for life and do not require greasing.

3.8 TRANSPORTING



TRANSPORT SAFETY

1. Make sure you are in compliance with all local regulations regarding transporting equipment on public roads and highways including lights, reflectors and the SMV.
2. Maximum transport speed for implement is 20 mph (32 kph). **DO NOT EXCEED**. Never travel at a speed which does not allow adequate control of steering and stopping. Reduce speed on rough roads and surfaces.
3. Do not allow anyone to ride on the implement or tractor during transport.
4. Sudden braking can cause a towed implement to swerve and upset.
5. **DO NOT** tow a load that is more than double the weight of the tractor.

When transporting the machine, review and follow these instructions:

1. Be sure all bystanders are clear of the machine.
2. A safety chain will help control towed implement should it separate from the tractor. **DO NOT** use safety chain for towing.
3. Be sure you have installed extra weights on the tractor if required.
4. Clean the SMV emblem, lights and reflectors and be sure they are working. Comply with all local regulations.
5. Carry implement low when moving or transporting.
6. Stay away from overhead power lines. Electrocution can occur without direct contact.
7. Be sure your machine can clearly be seen by overtaking and oncoming traffic.
8. Do not allow riders.
9. Always use hazard flashers on the tractor when transporting unless prohibited by law.

3.9 STORAGE



STORAGE SAFETY

1. Store the unit in an area away from human activity.
2. Do not permit children to play on or around the stored machine.
3. Store the unit in a dry, level area. Support the frame with planks if required.

After the season's use, the machine should be thoroughly inspected and prepared for storage. Repair or replace any worn or damaged components to prevent any unnecessary down time at the start of next season. To insure a long, trouble free life, this procedure should be followed when preparing the unit for storage:

1. Clear the area of bystanders, especially small children.
2. Thoroughly wash the machine using a pressure washer to remove all dirt, mud, debris and residue.
3. Inspect the Disc and frame for damage or entangled material. Repair or replace damaged parts. Remove all entangled material.
4. Touch up all paint nicks and scratches to prevent rusting. Spray the cutting blades with a rust inhibitor or paint to prevent rust.
5. Inspect all bearings for wear. Replace any worn out bearings.
6. Select an area that is dry, level, free of debris and away from human activity.
7. Inspect all nuts for tightness. Torque loose nuts to correct torque value.
7. If the machine cannot be placed inside, cover with a waterproof tarpaulin and tie securely in place.
9. Replace any decals that are worn or damaged.
10. Do not allow children to play on or around the stored implement.

4 TROUBLE SHOOTING

The Gearmore Offset Disc is a simple and reliable implement that requires minimal maintenance.

In the following section, we have listed many of the problems, causes and solutions to the problems that you may encounter.

If you encounter a problem that is difficult to solve, even after having read through this trouble shooting section, please call your local dealer or distributor. Before you call, please have this Operator's Manual and the serial number from your Offset Disc ready.

PROBLEM	CAUSE	SOLUTION
Shallow penetration	Insufficient weight	Add weight
Digging too deep	Soil is too loose	Reduce the gang angle cut
Not Digging deep enough		Increase the gang angle cut
Front wheels come off ground when starting suddenly	Not enough weight on tractor	Add sufficient weight to front end of tractor
Ridging occurs	Sometimes caused by rear outer discs	Change tractor speed Shorten upper link Combination of both solutions

5 ASSEMBLY

The discs are shipped partially assembled to reduce shipping costs.

When preparing for the customer, follow this limited procedure:

1. Bolt the A-frame in the correct operating position.
2. Adjust disc gang at the best angles depending on the typical soil conditions in your area.
3. Advise customers that they can adjust disc gangs if more or less aggressive action is required. The sharper the gang angles, the more aggressive the digging action.
4. Check all bolts and nuts to make sure they are tight.
5. The bolt and bushing installed in the top link is for use with a A.S.A.E. quick hitch.

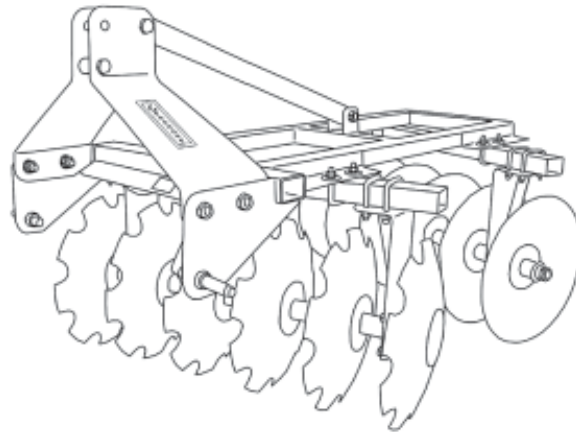

6 SPECIFICATIONS

6.1 MECHANICAL

MODELS	C1218	C1418	C1618	D1818	D2018
CUTTING WIDTH:	42"	48"	54"	60"	66"
APPROX. HP REQUIRED:	14 HP	16 HP	18 HP	22 HP	24 HP
NO. OF BLADES:	12	14	16	18	20
WEIGHT:	375 LBS.	420 LBS.	480 LBS.	620 LBS.	670 LBS.

SPECIFICATIONS ARE SUBJECT TO CHANGE WITHOUT NOTICE

6.2 BOLT TORQUE

CHECKING BOLT TORQUE

The tables shown below give correct torque values for various bolts and capscrews. Tighten all bolts to the torques specified in chart unless otherwise noted. Check tightness of bolts periodically, using bolt torque chart as a guide. Replace hardware with the same strength bolt.

ENGLISH TORQUE SPECIFICATIONS

Bolt Diameter "A"	Bolt Torque *					
	SAE 2		SAE 5		SAE 8	
	N.m	(lb-ft)	N.m	(lb-ft)	N.m	(lb-ft)
1/4"	8	(6)	12	(9)	17	(12)
5/16"	13	(10)	25	(19)	36	(27)
3/8"	27	(20)	45	(33)	63	(45)
7/16"	41	(30)	72	(53)	100	(75)
1/2"	61	(45)	110	(80)	155	(115)
9/16"	95	(70)	155	(115)	220	(165)
5/8"	128	(95)	215	(160)	305	(220)
3/4"	225	(165)	390	(290)	540	(400)
7/8"	230	(170)	570	(420)	880	(650)
1"	345	(225)	850	(630)	1320	(970)

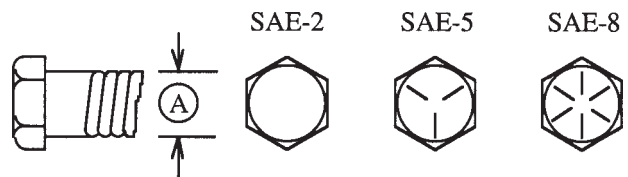

Torque figures indicated above are valid for non-greased or non-oiled threads and heads unless otherwise specified. Therefore, do not grease or oil bolts or capscrews unless otherwise specified in this manual. When using locking elements, increase torque values by 5%.

* Torque value for bolts and capscrews are identified by their head markings.

7 LIMITED WARRANTY



GEARMORE, INC., warrants each new Gearmore product to be free from defects in material and workmanship for a period of twelve (12) months from date of purchase to the original purchaser. This warranty shall not apply to implements or parts that have been subject to misuse, negligence, accident, or that have been altered in any way.

Our obligation shall be limited to repairing or replacement of any part, provided that such part is returned within thirty (30) days from date of failure to Gearmore through the dealer from whom the purchase was made, transportation charges prepaid.

This warranty shall not be interpreted to render us liable for injury or damages of any kind or nature, direct, consequential or contingent, to person or property. This warranty does not extend to loss of crops, loss because of delay in harvesting or any other expenses, for any other reasons.

Gearmore in no way warrants engines, tires, or other trade accessories, since these items are warranted separately by these respective manufacturers.

Gearmore reserves the right to make improvements in design or changes in specification at any time, without incurring any obligations to owners or units previously sold.

GEARMORE, INC.
13477 Benson Ave.
Chino, CA 91710

Always refer to and heed machine operating warning decals on machine.

The serial number of this product is stored in our computer database, thus submitting a warranty registration card is not required.