

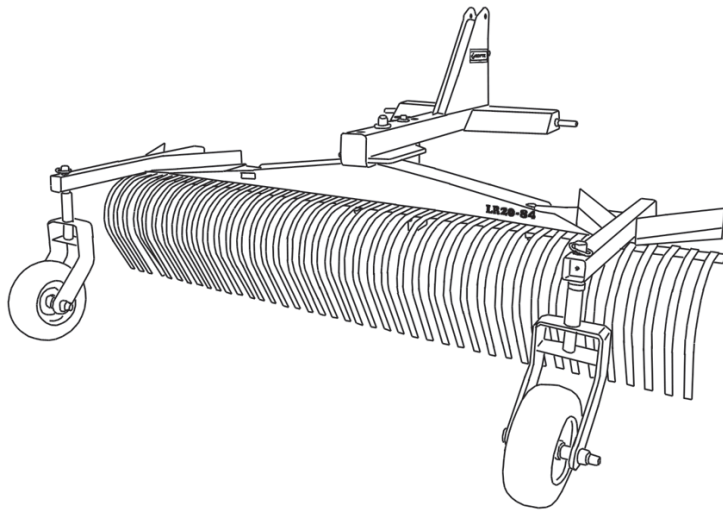

LANDSCAPE RAKE



**Operation & Parts Manual For
20 Series
LR20-60 & LR20-72**

April 2008

TABLE OF CONTENTS

	PAGE
Introduction.....	1
Checklists.....	2
General Information.....	3
Safety Rules.....	4
Federal Laws & Regulations.....	5
Operation Safety.....	6
Operation.....	7
Attachment to Tractor.....	7
Detaching from Tractor.....	7
Transport & Maintenance.....	8
Torque Specifications.....	9
Parts	
Series 20 Parts.....	10
Limited Warranty.....	11

INTRODUCTION

To THE DEALER:

Assembly and proper installation of this product is the responsibility of the dealer. Read manual instructions and safety rules. Make sure all items on the *Preparation Check List* in the Operator's Manual are completed before releasing equipment to the owner.

To THE OWNER:

Read this manual before operating your equipment. Keep this manual handy for ready reference. Require all operators to read this manual carefully and become acquainted with all adjustments and operating procedures before attempting to operate the equipment. Replacement manual can be obtained from your selling dealer.

The equipment you have purchased has been carefully engineered and manufactured to provide dependable and satisfactory use. Like all mechanical products, it will require cleaning and upkeep. Lubricate the unit as specified. Please observe all safety information in this manual and safety decals on the equipment.

For service, your authorized dealer has trained mechanics, genuine service parts, and the necessary tools and equipment to handle all of your service needs.

Use only genuine service parts. Substitute parts will void the warranty and may not meet standards required for safe and satisfactory operation. Record the model number and serial number of your equipment in the warranty page of this manual.

Throughout this manual, the term **IMPORTANT** is used to indicate that failure to observe procedures can cause damage to equipment. The terms **CAUTION**, **WARNING** and **DANGER** are used in conjunction with the Safety-Alert Symbol, (a triangle with an exclamation mark), to indicate the degree of hazard for items of personal safety.



!LEA EL INSTRUCTIVO!
Si no lee Ingles, pida ayuda a alguien que si lo lea para que le traduzca las medidas de seguridad.



This Safety-Alert Symbol indicates a hazard and means **ATTENTION! BECOME ALERT! YOUR SAFETY IS INVOLVED!**



Indicates an imminently hazardous situation that, if not avoided, will result in death or serious injury.



WARNING

Indicates a potentially hazardous situation that, if not avoided, could result in death or serious injury, and includes hazards that are exposed when guards are removed.



CAUTION

Indicates a potentially hazardous situation that, if not avoided, may result in minor or moderate injury.

IMPORTANT

Indicates that failure to observe can cause damage to equipment.

NOTE

Indicates helpful information.

DEALER PREPARATION CHECKLIST

THIS CHECKLIST TO REMAIN IN OWNER'S MANUAL

IT IS THE RESPONSIBILITY OF THE DEALER TO COMPLETE THE PROCEDURES LISTED BELOW BEFORE THE DELIVERY OR THE SALE OF THIS IMPLEMENT TO THE CUSTOMER.

Dealer Preparation Check List

- 1. Implement is completely assembled.
- 2. All fasteners torqued to specifications given in Torque Chart. (See page)
- 3. All decals in place and readable.
- 4. All guards in place and in good operating order.
- 5. Overall condition good. (paint, welds, etc.)
- 6. Operator's Manual has been delivered to owner.
- 7. Owner has been instructed on the safe and proper use of the implement.

It is the dealer's responsibility to complete the procedures listed above before delivery of this implement to the customer.

WARNING

For Non-Agricultural use OSHA, ASAE, SAE, and ANSI standards require the use of Chain Guards or other protective guards at all times. Manufacturer strongly recommends the use of such guards for Agricultural uses as well, to reduce the risk of property damage, serious bodily injury or even death from objects thrown out by or from contact with the cutting blades.

Dealer's Signature: _____

Purchaser's Signature: _____

GENERAL INFORMATION

The purpose of this manual is to assist you in operating and maintaining your rear blade for years of service. Read it carefully. The information and instructions in this manual have been compiled from extensive field experience and engineering data. Some information may be general in nature due to unknown and varying operating conditions. However, through experience and these instructions, you should be able to develop procedures suitable to your particular situation.

The illustrations and data used in this manual were current at the time of printing, but because we maintain an ongoing program of product improvement, we reserve the right to make improvements in design or changes in specifications without incurring any obligation to install them on units previously sold. Because of the possibility that some photographs in this manual were taken of prototype models, production models may vary in some detail.



WARNING: Some illustrations in this manual show the implement with safety shields removed to provide a better view. The implement should never be operated with any safety shielding removed.

Throughout this manual, references are made to right and left direction. These are determined by standing behind the equipment facing the direction of forward travel. Blade rotation is counter-clockwise as viewed from the top of the mower.

All information, illustrations and specifications in this manual are based on the latest information available at the time of publication. The right is reserved to make changes at any time without notice.

RETAIL CUSTOMER'S WARRANTY RESPONSIBILITY

It is the Retail Customer and/or Operator's responsibility to read the Operator's Manual, to operate, lubricate, maintain and store the product in accordance with all instructions and safety procedures. Failure of the operator to read the Operator's Manual is a misuse of this equipment. It is the Retail Customer and/or Operator's responsibility to inspect the product and to have any part(s) repaired or replaced when continued operation would cause damage or excessive wear to other parts or cause a safety hazard. It is the Retail Customer's responsibility to deliver the product to the authorized dealer from whom he purchased it, for service or replacement of defective parts which are covered by warranty. Repairs to be submitted for warranty consideration must be made within thirty (30) days of failure. It is the Retail Customer's responsibility for any cost incurred by the dealer for traveling to or hauling of the product for the purpose of performing a warranty obligation or inspection.

SAFETY RULES



ATTENTION! BECOME ALERT! YOUR SAFETY IS INVOLVED!



Safety is a primary concern in the design and manufacture of our products. Unfortunately, our efforts to provide safe equipment can be wiped out by an operator's single careless act. In addition to the design and configuration of equipment, hazard control and accident prevention are dependent upon the awareness, concern, judgment, and proper training of personnel involved in the operation, transport, maintenance, and storage of equipment.

Lack of attention to safety can result in accident, personal injury, reduction of efficiency and worst of all - loss of life. Watch for safety hazards and correct deficiencies promptly. Use the following safety precautions as a general guide to safe operations when using this machine. Additional safety precautions are used throughout this manual for specific operating and maintenance procedures. Read this manual and review the safety precautions often until you know the limitations.

It has been said "*The best safety device is an informed, careful operator.*" We ask you to be that kind of operator.

1. Read the Operator's Manual. Failure to read the Operator's Manual is considered a misuse of this equipment.
2. Become familiar with all the machine's controls and all the caution, warning, and danger decals affixed to the machine before attempting to start or operate.
3. Before starting or operating the machine, make a walk around inspection and check for obvious defects such as loose mounting bolts and damaged components. Correct any deficiency before starting.
4. Do not allow children to operate the implement. Do not allow adults to operate it without proper instruction.
5. Do not carry passengers.
6. Keep the area of operation clear of all persons, particularly small children and pets. The operator should cease operation whenever anyone comes within the area.
7. Lower implement to ground, stop tractor engine and apply parking brake before leaving the tractor.
8. Keep hands and feet away from implement.
9. Wear personal protective equipment such as, but not limited to, protection for eyes, ears, feet, hands, and head when operating or repairing the equipment. Do not wear loose clothing or jewelry that may catch on equipment moving parts.
10. When performing adjustments or maintenance on the implement, first lower it to the ground or block it securely at a workable height.
11. Never stand between tractor and implement while tractor is being backed to the hitch.
12. Reduce speed when transporting implement to avoid bouncing and momentary loss of steering.
13. Use tractor flashing warning lights, day or night, when transporting implement on road or highways unless prohibited by law.
14. It is recommended that tractor be equipped with Rollover Protective System (ROPS) and seat belt be used in all implement operations.

SAFETY RULES



IMPORTANT FEDERAL LAWS AND REGULATIONS* CONCERNING EMPLOYERS, EMPLOYEES AND OPERATIONS.



*(This section is intended to explain in broad terms the concept and effect of the following federal laws and regulations. It is not intended as a legal interpretation of the laws and should not be considered as such).

U.S. Public Law 91-596 (The Williams-Steiger Occupational and Health Act of 1970) OSHA

This Act Seeks:

"...to assure so far as possible every working man and woman in the nation safe and healthful working conditions and to preserve our human resources..."

DUTIES

Sec. 5

(a) Each employer -

- (1.) shall furnish to each of his employees employment and a place of employment which are free from recognized hazards that are causing or are likely to cause death or serious physical harm to his employees;
- (2.) shall comply with occupational safety and health standards promulgated under this Act.

(b) Each employee shall comply with occupational safety and health standards and all rules, regulations and orders issued pursuant to the Act which are applicable to his own actions and conduct.

OSHA Regulations

Current OSHA regulations state in part: "At the time of initial assignment and at least annually thereafter, the employer shall instruct every employee in the safe operation and servicing of all equipment with which the employee is, or will be involved." These will include (but are not limited to) instructions to:

- ~ Keep all guards in place when the machine is in operation;
- ~ Permit no riders on equipment;
- ~ Stop engine, disconnect the power source, and wait for all machine movement to stop before servicing, adjusting, cleaning, or unclogging the equipment, except where the machine must be running to be properly serviced or maintained, in which case the employer shall instruct employees as to all steps and procedures which are necessary to safely service or maintain the equipment.
- ~ Make sure everyone is clear of machinery before starting the engine, engaging power, or operating the machine.

Child Labor Under 16 Years Old

Some regulations specify that no one under the age of 16 may operate power machinery. It is your responsibility to know what these regulations are in your own area or situation. (Refer to U.S. Dept. of Labor, Employment Standard Administration, Wage & Home Division, Child Labor Bulletin #102.)

SAFETY RULES



EMPLOYEE TRACTOR OPERATION INSTRUCTIONS!



1. Securely fasten your seat belt if the tractor has a ROPS.
2. Where possible, avoid operating the tractor near ditches, embankments, and holes.
3. Reduce speed when turning, crossing slopes, and on rough, slick, or muddy surfaces.
4. Stay off slopes too steep for safe operation.
5. Watch where you are going, especially at row ends, on roads, and around trees.
6. Do not permit others to ride.
7. Operate the tractor smoothly - no jerky turns, starts, or stops.
8. Hitch only to the drawbar and hitch points recommended by tractor manufacturers.
9. When tractor is stopped, set brakes securely and use park lock if available.

OPERATION



**DURING ADJUSTMENT KEEP BODY, HANDS,
AND FEET CLEAR OF IMPLEMENT**



GENERAL SAFETY

Only qualified people should operate this machine. Wear close fitting clothing and safety equipment appropriate to the job. It is recommended that tractor be equipped with Rollover Protective Systems (ROPS) and a seat belt be used. Before beginning operation, clear work area of objects that may be picked up and thrown. Check for ditches, stumps, holes, or other obstacles that could upset tractor or damage rotary cutter. Always turn off tractor engine, set parking brake, and allow rotary cutter blades to come to a complete stop before dismounting.

● ATTACHMENT TO TRACTOR

1. The implement should be placed on level ground. Place the tractor 3-point lift arm control in "position control" (non-floating) for attaching and detaching the rear mounted implement. "Draft control" or "position control" can be used while operating. Attach the top link to the top hitch mount and adjust so that the frame will be level in the operating position.
2. Back the tractor until the ends of the lift arms can be attached to the bottom clevis pins on the implement. Secure the lift arms to the clevis pins.
3. Slowly move implement throughout the lift cycle of the tractor watching for interference between implement and tractor. Adjust top link, if necessary to provide additional clearance.

● DETACHING FROM TRACTOR

1. Lower the implement to the ground with 3-point lift arm control in "position control".
2. Remove top link from top hitch mount, disconnect hitch arms from bottom clevis pins and pull tractor away from implement.

● OPERATION

LOWER THE IMPLEMENT AS MUCH AS POSSIBLE AND SECURELY SUPPORT BEFORE MAKING ANY ADJUSTMENT.

1. Level the implement from side to side and front to rear using adjustments on the tractor's 3-point lift.
2. Care should be exercised during use of the implement to prevent hanging the ends on immovable objects or otherwise use the implement under conditions beyond its designed capacity.

TRANSPORT & MAINTENANCE

- **TRANSPORTATION**

WHEN EQUIPMENT IS TRANSPORTED, USE NECESSARY DEVICES REQUIRED BY LOCAL REGULATIONS FOR ADEQUATE WARNING TO OPERATORS OF OTHER VEHICLES.

- **MAINTENANCE**

1. Proper maintenance and service is the key to long life of any farm equipment. With regular inspection and lubrication of vital parts you can avoid many costly repairs and downtime.
2. Inspect your implement periodically and replace any worn or broken parts in order to have it ready for use when needed.
3. Store the implement out of the weather when it is not in use. This helps prevent rusting of the blades and other components.
4. Tines and/or blades should be cleaned immediately after use for easier cleaning.

TORQUE SPECIFICATIONS

TORQUE SPECIFICATIONS

Proper torque for American fasteners used on manufacturer implement.
Recommended Torque in Foot Pounds (Newton Meters).*

AMERICAN Bolt Head Markings



SAE Grade 2
(No Dashes)



SAE Grade 5
(3 Dashes)

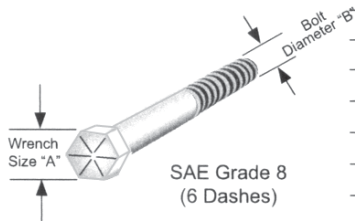

SAE Grade 8
(6 Dashes)

WRENCH SIZE (IN.) "A"	BOLT DIAMETER (IN.) "B" AND THREAD SIZE	SAE GRADE 2	SAE GRADE 5	SAE GRADE 8
7/16	1/4 -20 UNC	6 (7)	8 (11)	12 (16)
7/16	1/4 - 2/ UNF	6 (8)	10 (13)	14 (18)
1/2	5/16 -18 UNC	11 (15)	17 (23)	25 (33)
1/2	5/16 - 24 UNF	13 (17)	19 (26)	27 (37)
9/16	3/8 - 16 UNC	20 (27)	31 (42)	44 (60)
9/16	3/8 -24 UNF	23 (31)	35 (47)	49 (66)
5/8	7/16 -14 UNC	32 (43)	49 (66)	70 (95)
5/8	7/16 - 20 UNF	36 (49)	55 (75)	78 (106)
3/4	1/2 - 13 UNC	49 (66)	76 (103)	106 (144)
3/4	1/2 - 20 UNF	55 (75)	85 (115)	120 (163)
7/8	9/16 -12 UNC	70 (95)	109 (148)	153 (207)
7/8	9/16 - 18 UNF	79 (107)	122 (165)	172 (233)
15/16	5/8 - 11 UNC	97 (131)	150 (203)	212 (287)
15/16	5/8 - 18 UNF	110 (149)	170 (230)	240 (325)
1-1/8	3/4 - 10 UNC	144(195)	266 (360)	376 (509)
1-1/8	3/4 - 16 UNF	192 (260)	297 (406)	420 (569)
1-5/16	7/8 - 9 UNC	166 (225)	430 (583)	606 (821)
1-5/16	7/8 - 14 UNF	184 (249)	474 (642)	668 (905)
1-1/2	1-8 UNC	250 (339)	644 (873)	909 (1232)
1-1/2	1 - 12 UNF	274 (371)	705 (955)	995 (1348)
1-1/2	1-14 UNF	280 (379)	721 (977)	1019 (1381)
1-11/16	1-1/8 - 7 UNC	354 (480)	795 (1077)	1288 (1745)
1-11/16	1-1/8 -12 UNF	397 (538)	890 (1206)	1444 (1957)
1-7/8	1-1/4 - 7 UNC	500 (678)	1120 (1518)	1817 (2462)
1-7/8	1-1/4 - 12 UNF	553 (749)	1241 (1682)	2013 (2728)
2-1/16	1-3/8 - 6 UNC	655 (887)	1470 (1992)	2382 (3228)
2-1/16	1-3/8 -12 UNF	746 (1011)	1672 (2266)	2712 (3675)
2-1/4	1-1/2 - 6 UNC	870 (1179)	1950 (2642)	3161 (4283)
2-1/4	1-1/2 - 12 UNF	979 (1327)	2194 (2973)	3557 (4820)

METRIC

Proper torque for metric fasteners used on manufacturer implement.
Recommended Torque in Foot Pounds (Newton Meters).*

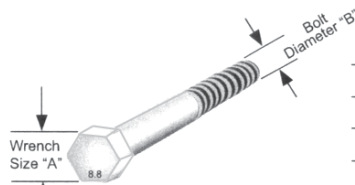

Numbers appearing on bolt heads indicate ASTM classes.

WRENCH SIZE (mm) "A"	BOLT DIA. (mm) "B"	ASTM 4.6	ASTM 8.8	ASTM 9.8	ASTM 10.9
8	5	1.8 (2.4)		5.1 (6.9)	6.5 (8.8)
10	6	3 (4)		8.7 (12)	11.1 (15)
13	8	7.3 (10)		21.1 (29)	27 (37)
16	10	14.5 (20)		42 (57)	53 (72)
18	12	25 (34)	74 (100)	73 (99)	93 (126)
21	14	40 (54)	118 (160)	116 (157)	148 (201)
24	16	62 (84)	167 (226)	181 (245)	230 (312)
30	20	122 (165)	325 (440)		449 (608)
33	22		443 (600)		611 (828)
36	24	211 (286)	563 (763)		778 (1054)
41	27		821 (1112)		138(1542)
46	30	418 (566)	1119 (1516)		1547(2096)

*Use 75% of the specified torque value for plated fasteners. Use 85% of the specified torque values for lubricated fasteners.

20 SERIES LANDSCAPE RAKE PARTS

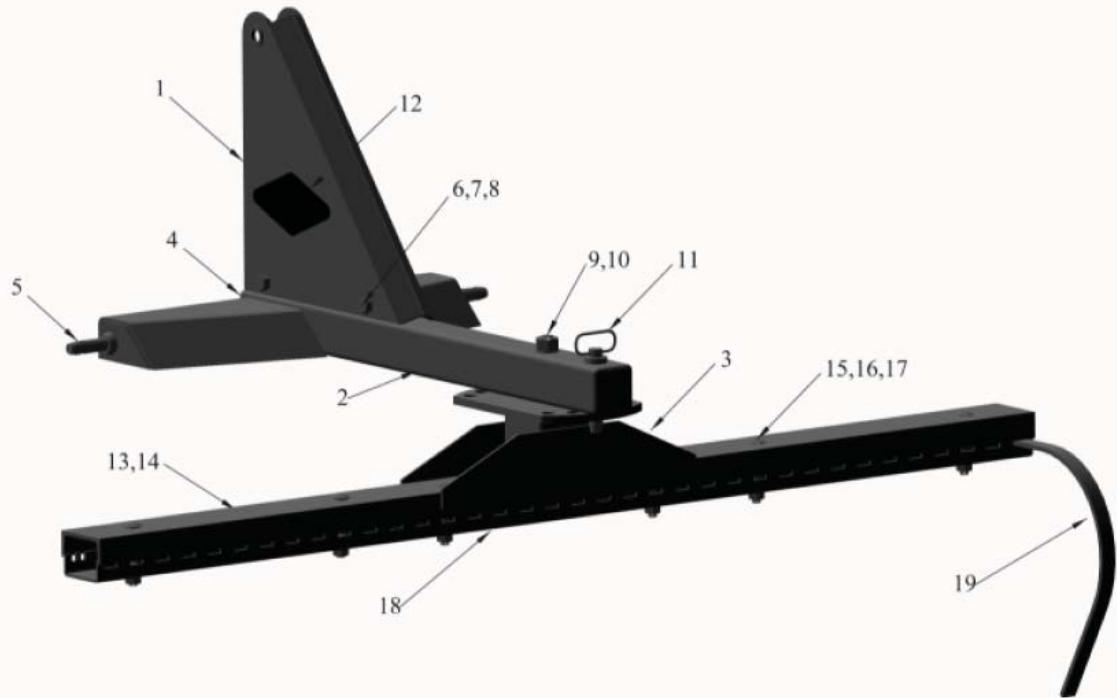

ITEM #	Description	LR20-60	LR20-72	LR20-84
1	Hitch Top Link	UH20-00-SA	UH20-00-SA	UH20-00-SA
2	Hitch Main Frame	UH20-00-SB	UH20-00-SB	UH20-00-SB
3	Rake Frame	LR20-60-SE	LR20-72-SE	LR20-84-SE
4	Cap, 3"x3", Black, Plastic	VCAP3.000x3.000BP	VCAP3.000x3.000BP	VCAP3.000x3.000BP
5	Lift Pin, Cat 1, Threaded	VLIFTPIN1	VLIFTPIN1	VLIFTPIN1
6	Hex Bolt, 9/16"x4", NC, Plated	VHB0.5625x4.000NCP	VHB0.5625x4.000NCP	VHB0.5625x4.000NCP
7	Hex Nut, 9/16", NC, Plated	VHN0.5625NCP	VHN0.5625NCP	VHN0.5625NCP
8	Lock Washer, 9/16", Plated	VLW0.5625P	VLW0.5625P	VLW0.5625P
9	Lock Nut, 7/8", Plated	VLN0.8750NCP	VLN0.8750NCP	VLN0.8750NCP
10	Flat Washer, 7/8", Plated	VFW0.8750P	VFW0.8750P	VFW0.8750P
11	Pull Pin, 7/8" x 4 1/4"	VPIN0.8750x4.2500	VPIN0.8750x4.2500	VPIN0.8750x4.2500
12	Brand Label	VLBLMIDWEST	VLBLMIDWEST	VLBLMIDWEST
13	Serial Number Label	VLBLSERIAL	VLBLSERIAL	VLBLSERIAL
14	Model Number Label	VLBLRB1548	VLBLRB1560	VLBLRB1572
15	Lock Washer, 5/8", Plated	VLW0.6250P	VLW0.6250P	VLW0.6250P
16	Hex Nut, 5/8", NC, Plated	VHN0.6250NCP	VHN0.6250NCP	VHN0.6250NCP
17	Carriage Bolt, 5/8"x4", NC, Plated	VCB0.6250x4.000NCP	VCB0.6250x4.000NCP	VCB0.6250x4.000NCP
18	Tine Spacer 24"	LR00-24-02	LR00-24-02	LR00-24-02
19	5/16"x1" Rake Tine	VTINE	VTINE	VTINE

LIMITED WARRANTY



GEARMORE, INC., warrants each new Gearmore product to be free from defects in material and workmanship for a period of twelve (12) months from date of purchase to the original purchaser. This warranty shall not apply to implements or parts that have been subject to misuse, negligence, accident, or that have been altered in any way.

Our obligation shall be limited to repairing or replacement of any part, provided that such part is returned within thirty (30) days from date of failure to Gearmore through the dealer from whom the purchase was made, transportation charges prepaid.

This warranty shall not be interpreted to render us liable for injury or damages of any kind or nature, direct, consequential or contingent, to person or property. This warranty does not extend to loss of crops, loss because of delay in harvesting or any other expenses, for any other reasons.

Gearmore in no way warrants engines, tires, or other trade accessories, since these items are warranted separately by these respective manufacturers.

Gearmore reserves the right to make improvements in design or changes in specification at any time, without incurring any obligations to owners or units previously sold.

GEARMORE, INC.
13477 Benson Ave.
Chino, CA 91710

Always refer to and heed machine operating warning decals on machine.

The serial number of this product is stored in our computer database, thus submitting a warranty registration card is not required.

CUSTOMER INFORMATION

NAME: _____

PURCHASED FROM: _____

DATE OF PURCHASE: _____

MODEL NUMBER: _____

SERIAL NUMBER: _____