

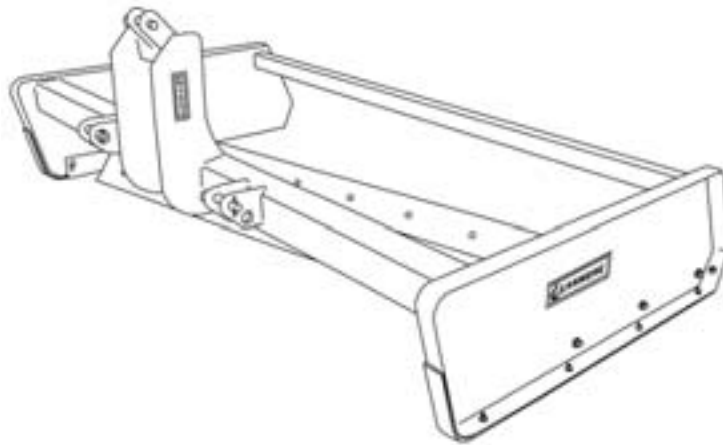

# **GRADING SCRAPERS**

## **INDUSTRIAL SERIES**



**OPERATION, SERVICE  
& PARTS MANUAL FOR MODELS:  
GSI7-SS, GSI7, GSI8, GSI10, & GSI12**

**September 2006**

# TABLE OF CONTENTS

Safety Information .....	1-2
Introduction .....	3
Attaching to Tractor .....	3
Operating Instructions .....	4
Instructions for Road Maintenance .....	5
Industrial Grading Scraper Parts List .....	6-7
Limited Warranty .....	8

Date of Purchase: \_\_\_\_\_

Model Number: \_\_\_\_\_

Serial Number \_\_\_\_\_

# SAFETY INFORMATION

These are important safety practices that apply to tractors and implements.

## SIGNAL WORDS

A Signal Word designates a degree or level of hazard seriousness.

The signal words are:

### **DANGER!**

Indicates an imminently hazardous situation which, if not avoided, will result in death or serious injury. This signal word is limited to the most extreme situations, typically for machine components that, for functional purposes, cannot be guarded.

### **WARNING!**

Indicates a potentially hazardous situation which, if not avoided, could result in death or serious injury, and includes hazards that are exposed when guards are removed. It may also be used to alert against unsafe practices.

### **CAUTION!**

Indicates a potentially hazardous situation which, if not avoided, may result in minor or moderate injury. It may also be used to alert against unsafe practices.

## KEEP RIDERS OFF MACHINERY

- ▲ Riders obstruct the operator's view, they could be struck by foreign objects or thrown from the machine.
- ▲ Never allow children to operate equipment



This is the safety alert symbol. It means:  
**ATTENTION! BECOME ALERT!  
YOUR SAFETY IS INVOLVED!**



### **WARNING!**

When operating the grading scraper, you must have added weight to the front of the tractor to insure stability. The added weight can be front weights or front loader.



### **DANGER!**

If you are working under or around the grading scraper, you must fully support the unit. **DO NOT** rely on the tractor hydraulic system to hold the grading scraper in place.

## FOR YOUR PROTECTION

- ▲ Thoroughly read and understand the "Safety Label" section, read all instructions noted on them.

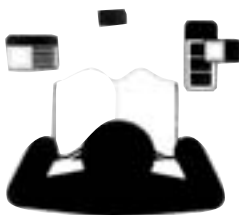

## SHUTDOWN AND STORAGE

- ▲ Lower machine to ground, put tractor in park, turn off engine, and remove the key.
- ▲ Detach and store implements in a area where children normally do not play. Secure implement by using blocks and supports.

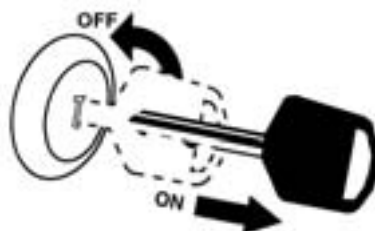

# SAFETY INFORMATION

## PRACTICE SAFE MAINTENANCE

- ▲ Understand procedure before doing work. Use proper tools and equipment, refer to Operator's Manual for additional information.
- ▲ Work in a clean dry area.
- ▲ Lower the implement to the ground, put tractor in park, turn off engine, and remove key before performing maintenance.
- ▲ Allow implement to cool completely.
- ▲ Do not grease or oil implement while it is in operation.
- ▲ Inspect all parts. Make sure parts are in good condition & installed properly.
- ▲ Remove build-up of grease, oil or debris.
- ▲ Remove all tools and unused parts from implement before operation.



## SAFETY AT ALL TIMES

Thoroughly read and understand the instructions given in this manual before operation. Refer to the "Safety Label" section, read all instructions noted on them.



- ▲ Operator should be familiar with all functions of the unit.
- ▲ Operate implement from the driver's seat only.
- ▲ Do not leave tractor or implement unattended with engine running.
- ▲ Dismounting from a moving tractor could cause serious injury or death.
- ▲ Do not stand between the tractor and implement during hitching.
- ▲ Keep hands, feet, and clothing away from power-driven parts.
- ▲ Wear snug fitting clothing to avoid entanglement with moving parts.
- ▲ Watch out for wires, trees, etc., when raising implement. Make sure all persons are clear of working area.
- ▲ Turning tractor too tight may cause implement to ride up on wheels. This could result in injury or equipment damage.

## WEAR PROTECTIVE EQUIPMENT

- ▲ Protective clothing and equipment should be worn.
- ▲ Wear clothing and equipment appropriate for the job. Avoid loose fitting clothing.
- ▲ Prolonged exposure to loud noise can cause hearing impairment or hearing loss. Wear suitable hearing protection such as earmuffs or earplugs.
- ▲ Operating equipment safely requires the full attention of the operator. Avoid wearing radio headphones while operating machinery.



# INTRODUCTION

Thank you for choosing the Gearmore Industrial Grading Scraper, a special tool that performs many different tasks.

This manual will explain how you can operate this special grading scraper as both a box scraper and road grader.

Safe, troublefree operation of your grading scraper requires that you and anyone else who will be operating or maintaining it read and understand the safety and operating instructions.

Keep this manual handy for future reference. Call your Gearmore dealer if you need assistance, information or additional copies of this manual.

Have a safe, and productive use of your new Gearmore Industrial Grading Scraper.

## ATTACHING INDUSTRIAL GRADER SCRAPER

1. Place the tractor and grading scraper on as level an area as possible.
2. Attach the tractor 3-point hitch or to a skid steer loader.
3. Make sure, when attaching to a tractor 3-point hitch, the bottom hitch arms are as rigid as possible by adjusting the hitch check chains. You do not want any side sway when the scraper is in operation.
4. Adjust the tractor top link so both cutting edges are on the ground. This is the normal operating position of the dual blade.
5. On skid steer/track loaders, make sure the quick attach bracket is locked in place.

# OPERATING INSTRUCTIONS

The grading scrapers are shipped with the dual cutting edge set 1/2" below the side panels, as this is the most popular setting, especially for road maintenance work.

More soil can be moved by simply lowering the cutting edge.

## **BLADE ADJUSTMENT:**

If you want to lower the blades due to wear or to move more soil, the correct way to do the adjustment is in the following manner:

- a. Park the grading scraper on a smooth, hard surface; concrete surface is the best.
- b. Raise the grading scraper with the tractor 3-point lift system.
- c. Obtain two narrow blocks, approximately two feet long, with the thickness you would like to try; say 3/4 inch.
- d. With nobody on the tractor for safety reasons, place the block under the side panel flange, taking care that the blocks do not protrude under the cutting edge.
- e. Lower the grading scraper onto the spacer blocks and then loosen the 3 bolts on each side of blade assembly. The blades will then drop to the required position.
- f. Check to make sure the cutting edge is resting on the ground, then secure the 6 bolts so the blade assembly is locked in position.

# ROAD MAINTENANCE INSTRUCTIONS

1. Lower the right hand side of the tractor 3-point hitch side links 2 to 3 inches. This will allow you to "dome" your access roads for water drainage.
  - 1a. To angle the grading scraper on a skid steer tractor, it would require purchasing a skid steer "tilt plate".
2. Start on the far right hand side of the road. Make your first pass at a slow speed, approximately 2 miles per hour. This will allow the unit to cut out and fill holes. Work the far right side on the road and return by grading the opposite far side of the road. Continue until you reach the center.
3. To finish grade, it is usually necessary to make one more set of passes at a higher speed; approximately 7 miles per hour. The higher speeds allow the material to flow over the first blade, thoroughly mix between the two blades, then exit from the rear blade achieving a smooth finished road surface.

# INDUSTRIAL GRADING SCRAPER

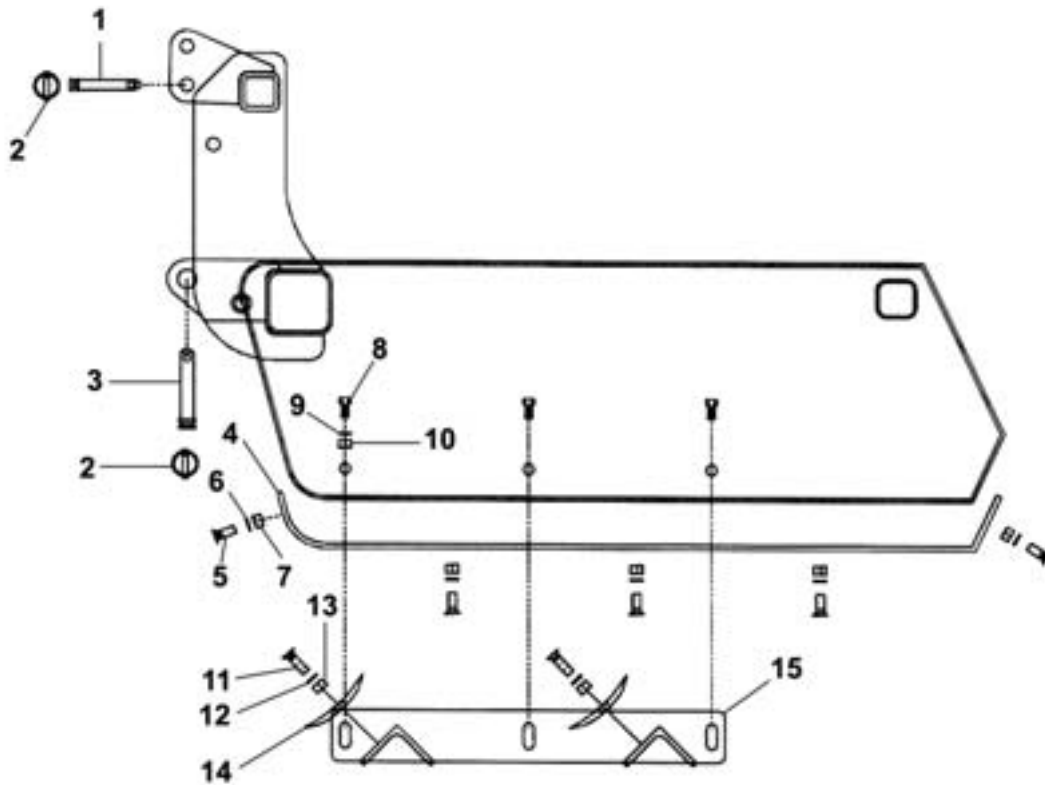

<u>REF #</u>	<u>QTY.</u>	<u>PART NO.</u>	<u>DESCRIPTION</u>
1	1	P075500C1TL	Cat. I Top Link Pin (GSI7* only)
1	1	P100500C2TL	Cat. II Top Link Pin (GSI7*, GSI8, GSI10, GSI12)
2	3	P716715LY	Lynch Pin 7/16" x 1 3/4" (GSI7, GSI8, GSI10, GSI12)
3	2	P078375C1D	Cat. I Draw Pin (GSI7* only)
3	2	P118500MD	Cat. II Draw Pin (GSI7*, GSI8, GSI10, GSI12)
4	2	F25GS101	Skid Plate
5	10	B038150CS	3/8" x 1 1/2" Hex Bolt
6	10	N038H	3/8" Nut Grade 5
7	10	W038F	3/8" Flat Washer
8	6	B058150	Bolt Plate Bolt 5/8" x 1 1/2"
9	6	W058F	Bolt Plate Bolt Washer 5/8"
10	6	N058H	Bolt Plate Bolt Nut 5/8"
11	7	B058200P	5/8" x 2" Plow Bolt (GSI7 & GSI7-SS)
11	8	B058200P	5/8" x 2" Plow Bolt (GSI8)
11	10	B058200P	5/8" x 2" Plow Bolt (GSI10)
11	12	B058200P	5/8" x 2" Plow Bolt (GSI12)



# INDUSTRIAL GRADING SCRAPER

<u>REF #</u>	<u>QTY.</u>	<u>PART NO.</u>	<u>DESCRIPTION</u>
12	7	W058F	5/8" Flat Washer (GSI7 & GSI7-SS)
12	8	W058F	5/8" Flat Washer (GSI8)
12	10	W058F	5/8" Flat Washer (GSI10)
12	12	W058F	5/8" Flat Washer (GSI12)
13	7	N058H	5/8" Hex Nut (GSI7 & GSI7-SS)
13	8	N058H	5/8" Hex Nut (GSI8)
13	10	N058H	5/8" Hex Nut (GSI10)
13	12	N058H	5/8" Hex Nut (GSI12)
14	2	CE84	84" Cutting Edge (GSI7 & GSI7-SS)
14	2	CE96	96" Cutting Edge (GSI8)
14	2	CE120	120" Cutting Edge (GSI10)
14	2	CE144	144" Cutting Edge (GSI12)
15	1	A06GSI01A	Bolt Plate/CE Angle Assembly (GSI7 & GSI7-SS)
15	1	A06GSI02A	Bolt Plate/CE Angle Assembly (GSI8)
15	1	A06GSI03A	Bolt Plate/CE Angle Assembly (GSI10)
15	1	A06GSI04A	Bolt Plate/CE Angle Assembly (GSI12)

*\* Note: The GSI7 is designed for both Cat. I and II 3-point hitch.*

# LIMITED WARRANTY



GEARMORE, INC., warrants each new Gearmore product to be free from defects in material and workmanship for a period of twelve (12) months from date of purchase to the original purchaser. This warranty shall not apply to implements or parts that have been subject to misuse, negligence, accident, or that have been altered in any way.

Our obligation shall be limited to repairing or replacement of any part, provided that such part is returned within thirty (30) days from date of failure to Gearmore through the dealer from whom the purchase was made, transportation charges prepaid.

This warranty shall not be interpreted to render us liable for injury or damages of any kind or nature, direct, consequential or contingent, to person or property. This warranty does not extend to loss of crops, loss because of delay in harvesting or any other expenses, for any other reasons.

Gearmore in no way warrants engines, tires, or other trade accessories, since these items are warranted separately by these respective manufacturers.

Gearmore reserves the right to make improvements in design or changes in specification at any time, without incurring any obligations to owners or units previously sold.

GEARMORE, INC.  
13477 Benson Ave.  
Chino, CA 91710

Always refer to and heed machine operating warning decals on machine.

*The serial number of this product is stored in our computer database, thus submitting a warranty registration card is not required.*