

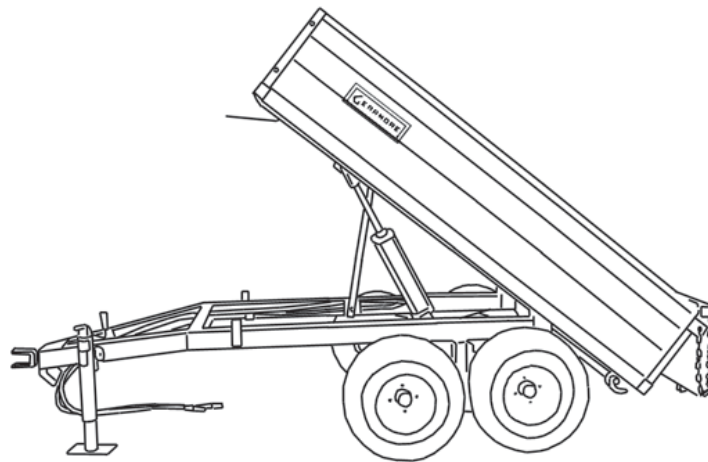

# DUMP TRAILERS



**Assembly, Parts & Operator's  
Manual For Models  
1.5T50x72, 2.5T60x99, 4T63x99,  
5T63x99 & 8T60x120**

**June 2006**

**DATE OF PURCHASE:** \_\_\_\_\_

**MODEL NUMBER:** \_\_\_\_\_

**SERIAL NUMBER:** \_\_\_\_\_

# TABLE OF CONTENTS

SECTION	DESCRIPTION	PAGE
<b>1</b>	<b>Introduction .....</b>	<b>1</b>
1.1	Bolt Torque Chart .....	1
<b>2</b>	<b>Safety .....</b>	<b>2</b>
2.1	Training .....	3
2.2	Safety Wear .....	3
2.3	Preparation .....	4
2.4	Operational Safety .....	5
2.5	Maintenance & Storage Safety .....	5
2.6	Transporting Safety .....	6
2.7	Safety Decals .....	6
<b>3</b>	<b>Operation Instructions .....</b>	<b>7</b>
3.1	Assembly Guide .....	7
3.2	Attaching .....	7
3.3	Transporting .....	8
3.4	Maintenance & Lubrication .....	8
3.5	Storage .....	8
<b>4</b>	<b>Specifications .....</b>	<b>9</b>
<b>5</b>	<b>Trailer Components .....</b>	<b>10</b>
5.1	1 1/2 Ton Trailer .....	10-11
5.2	2 1/2 Ton Trailer .....	12-13
5.3	4 Ton Trailer .....	14-15
5.4	5 Ton Trailer .....	16-17
5.5	8 Ton Trailer .....	18-19
5.6	1 1/2 Ton Tire & Whl. Hub Components .....	20
5.7	2 1/2 Ton Tire & Whl. Hub Components .....	21
5.8	4, 5 & 8 Ton Tire & Whl. Hub Components .....	22
5.9	1 1/2 Ton Hyd. Cylinder Components .....	23
5.10	2 1/2 Ton Hyd. Cylinder Components .....	24
5.11	4 & 5 Ton Hyd. Cylinder Components .....	25
5.12	4 & 5 Ton Hyd. Valve Components .....	26
5.13	8 Ton Hyd. Cylinder Components .....	27-28
5.14	8 Ton Hydraulic Components .....	29
5.15	Manual Hydraulic Pump Components .....	30
<b>6</b>	<b>Limited Warranty .....</b>	<b>31</b>

# 1 INTRODUCTION

Congratulations on your choice of Dump Trailers. This equipment has been designed and manufactured to meet the needs of a discriminating buyer.

Read this manual carefully to learn how to properly operate and service your Dump Trailer. Failure to do so could result in personal injury or equipment damage.

Throughout this manual, references are made to right and left direction. **RIGHT - HAND AND LEFT - HAND** sides are determined by standing behind the Dump Trailer facing the direction the Dump Trailer will travel when going forward.

The purpose of this manual is to assist you in operating and maintaining your Dump Trailer. Read it carefully. It furnishes information and instructions that will help you achieve years of dependable performance. These instructions have been compiled from extensive field experience and engineering data. Some information may be general in nature due to unknown and varying operating conditions.

However, through experience and these instructions, you should be able to develop procedures suitable to your particular situation. Maintain your Dump Trailer with original repair parts to insure optimum performance. For service, your authorized Gearmore dealer has trained mechanics, genuine service parts and the necessary tools and equipment to handle all your needs.

The illustrations and data used in this manual were current at the time of printing, but due to possible production changes, your trailer may vary slightly in detail. The manufacturer reserves the right to redesign and change the machines, as may be necessary, without notification.

This Dump Trailer is for **off-highway uses only**. Do not use this trailer on highways.

## 1.1 BOLT TORQUE CHART

**GRADE 2**

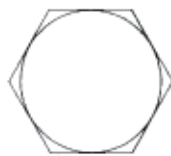

**GRADE 5**



**GRADE 8**



### TORQUE IN FOOT POUNDS (NEWTON METERS)

BOLT SIZE		$\frac{3}{8}$	$\frac{1}{2}$	$\frac{5}{8}$	$\frac{3}{4}$	$\frac{7}{8}$	1
HEX HEAD		$\frac{9}{16}$	$\frac{3}{4}$	$\frac{15}{16}$	$1-\frac{1}{8}$	$1-\frac{5}{16}$	$1-\frac{1}{2}$
<b>G R A D E</b>	<b>2</b>	18 (24.4)	45 (61.0)	89 (120.7)	160 (216.9)	252 (341.6)	320 (433.9)
	<b>5</b>	30 (40.6)	68 (92.2)	140 (189.8)	240 (325.4)	360 (488.1)	544 (737.5)
	<b>8</b>	40 (54.2)	100 (135.6)	196 (265.7)	340 (460.9)	528 (715.1)	792 (1073.8)

## 2 SAFETY

### SAFETY ALERT SYMBOL

This Safety Alert symbol means **ATTENTION! BECOME ALERT! YOUR SAFETY IS INVOLVED!**

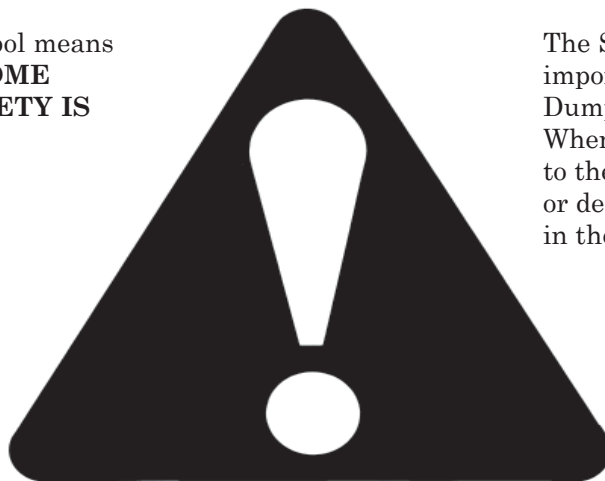

The Safety Alert symbol identifies important safety messages on the Dump Trailer and in the manual. When you see this symbol, be alert to the possibility of personal injury or death. Follow the instructions in the safety message.

Why is SAFETY important to you?

#### 3 Big Reasons

**Accidents Disable and Kill**  
**Accidents Cost**  
**Accidents Can Be Avoided**

#### SIGNAL WORDS:

Note the use of the signal words **DANGER**, **WARNING** and **CAUTION** with the safety messages. The appropriate signal word for each message has been selected using the following guide-lines:

**DANGER** - Indicates an imminently hazardous situation that, if not avoided, will result in death or serious injury. This signal word is to be limited to the most extreme situations typically for machine components which, for functional purposes, cannot be guarded.

**WARNING** - Indicates a potentially hazardous situation that, if not avoided, could result in death or serious injury, and includes hazards that are exposed when guards are removed. It may also be used to alert against unsafe practices.

**CAUTION** - Indicates a potentially hazardous situation that, if not avoided, may result in minor or moderate injury. It may also be used to alert against unsafe practices.

The word **IMPORTANT** is used to identify special instructions or procedures which, if not strictly observed could result in damage to, or destruction of the machine, process or its surroundings.

Replace any **DANGER**, **WARNING**, **CAUTION** or instructional decal that is not readable or is missing. The location and part number of these decals is identified later in this manual.

If you have any questions not answered in this manual or require additional copies or the manual is damaged, please contact your dealer.

## 2.1 TRAINING

Before operating this DumpTrailer, read and understand this manual completely. Become familiar with it for your own safety. To fail to do so may cause serious injury. **DO NOT** allow anyone to operate this Dump Trailer who has not read this manual.



Your personal safety is a primary concern in the design and manufacture of our products. Our efforts to provide such equipment can be wiped out by a single careless act of an operator. In addition to the design and configuration of equipment, hazard control and accident prevention are dependent upon the awareness, concern, prudence and proper training of personnel involved in the operation, transport, maintenance and storage of equipment.

It has been said "*The best safety device is an informed, careful operator.*" We ask you to be that kind of an operator.

The design of this equipment depends on it being operated within limitations as explained in this manual.

- **Safety instructions are important!** Read this manual and the tractor manual; follow all safety rules and safety decal information. (Replacement manuals are available from your dealer). Failure to follow instructions or safety rules can result in serious injury or death.
- If you do not understand any part of this manual and need assistance, see your dealer.
- Know your controls and how to stop engine and attachment quickly in an emergency.
- The operator must be instructed in and be capable of the proper operation of the equipment, its attachments and all controls. **DO NOT** allow anyone to operate this equipment without proper instructions.
- **DO NOT** allow children or untrained persons to operate equipment.

## 2.2 SAFETY WEAR

**ALWAYS** wear close fitting clothing and personal protection equipment called for by the job conditions. These items may include a hard hat, safety glasses, goggles or face shield, hearing protection and safety boots. **DO NOT** wear loose clothing, jewelry or any other items that may be entangled in moving parts. Tie up long hair.

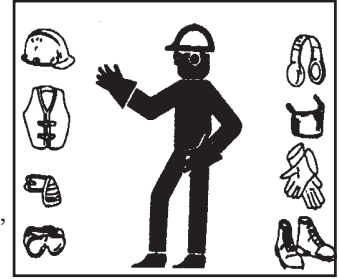

Have a first aid kit available should the need arise and learn how to use it.



**ALWAYS** wear protective hearing devices as needed.



### **PROLONGED EXPOSURE TO LOUD NOISE MAY CAUSE PERMANENT HEARING LOSS!**

Tractors with or without equipment attached can often be noisy enough to cause permanent, partial hearing loss. We recommend that you wear hearing protection on a full-time basis if the noise in the Operator's position exceeds 80db. Noise over 85db on a long-term basis can cause severe hearing loss. Noise over 90db adjacent to the Operator over a long-term basis may cause permanent, total hearing loss. **NOTE:** Hearing loss from loud noise (from tractors, chain saws, radios, and other such sources close to the ear) is cumulative over a lifetime without hope of natural recovery.

## 2.3 PREPARATION

Ensure trailer is properly mounted, adjusted and in good operating condition.

- ✓ Tighten all bolts and nuts and check that all cotter pins are installed securely to ensure equipment is properly assembled before operating.
- ✓ Check tire pressure.
- ✓ Check hydraulic connections.
- ✓ Check hoses for weak or worn conditions before each use.
- ✓ Make certain the power source conforms to the requirements of your trailer.

Tractor must be equipped with **ROPS FRAME** or **ROPS CAB** and seat belt. Keep seat belt securely fastened. Falling off tractor can result in death from being run over or crushed. Keep foldable ROPS systems in "locked up" position at all times.



- Remove accumulated debris from this equipment, tractor and engine to avoid fire hazard.
- Ensure all safety decals are installed. Replace if damaged. (*See Safety Decals section for location*).
- Ensure shields and guards are properly installed and in good condition. Replace if damaged.
- A minimum 20% of the combined tractor and dump trailer weight must be on the tractor front wheels with trailer in transport position. Without this weight, tractor could tip over causing personal injury or death. See your tractor operators manual for information regarding adding weights.

**YOU** are responsible for the **SAFE** operation and maintenance of your Dump Trailer. **YOU** must ensure that you and anyone else who is going to operate, maintain or work around the Dump Trailer be familiar with the operating and maintenance procedures and related **SAFETY** information contained in this manual. This manual will take you step-by-step through your working day and alerts you to all good safety practices that should be adhered to while operating the Dump Trailer.

Remember, **YOU** are the key to safety. Good safety practices not only protect you, but also the people around you. Make these practices a working part of your safety program. Be certain that **EVERYONE** operating this equipment is familiar with the recommended operating and maintenance procedures and follows all the safety precautions. Most accidents can be prevented. Do not risk injury or death by ignoring good safety practices.

- Dump Trailer owners must give operating instructions to operators or employees before allowing them to operate the machine, and at least annually thereafter per OSHA (Occupational Safety and Health Administration) regulation 1928.57.
- The most important safety feature on this equipment is a **SAFE** operator. It is the operator's responsibility to read and understand **ALL** Safety and Operating instructions in the manual and to follow these. Most accidents can be avoided.
- A person who has not read and understood all operating and safety instructions is not qualified to operate the machine. An untrained operator exposes himself and bystanders to possible serious injury or death.
- Do not modify the equipment in any way. Unauthorized modification may impair the function and/or safety and could affect the life of the equipment.
- **Think SAFETY! Work SAFELY!**

## 2.4 OPERATIONAL SAFETY

### OPERATE IN SAFE ENVIRONMENT AND ON SAFE GROUND

1. Keep bystanders away from equipment while it is in operation.
2. Operate only in daylight or good artificial light.
3. **ALWAYS** comply with all state and local lighting and marking requirements.
4. **DO NOT** allow other people in the area when operating, attaching, removing, assembling, or servicing trailer.
5. **NO RIDERS** are allowed on equipment.
6. **ALWAYS** sit in tractor with seat belt fastened when operating controls or starting engine. Place transmission in park or neutral, engage brake and ensure all other controls are disengaged before starting tractor engine. Keep bystanders away from equipment while it is in operation.
7. Look down and to the rear and make sure area is clear before operating in reverse.
8. Stand clear of the trailer during dumping to avoid becoming injured.
9. **DO NOT** operate on steep slopes.
10. **DO NOT** stop, start or change directions suddenly on slopes.
11. Use extreme care and reduce ground speed on slopes and rough terrain.
12. Watch for hidden hazards on the terrain during operation.
13. When performing any service or maintenance, disengage power to implement. Lower all raised components to the ground. Operate valve levers to release any hydraulic pressure. Stop engine, set parking brake and remove key before dismounting tractor.
14. Keep all persons away from operator control area while performing adjustments, service or maintenance.



## 2.5 MAINTENANCE & STORAGE SAFETY

Good maintenance is your responsibility. Poor maintenance is an invitation to trouble.

Before performing any service or maintenance, disconnect hydraulic hoses from tractor to keep these parts from moving.

Before performing any work under the raised platform, **ALWAYS** install a safety support.

Always use genuine replacement parts. Your dealer can supply genuine replacement parts. Substitute parts may not meet original equipment specifications.

*All replacement parts must meet manufacturer's specifications. The manufacturer will not be responsible for injuries or damages caused by use of unapproved parts and/or accessories.*

**DO NOT** climb or walk on trailer frame.

Keep all persons away from operator control area while performing adjustments, service or maintenance.

Be sure electrical outlets and tools are properly grounded.

Use adequate light for the job at hand.

Make sure there is plenty of ventilation. Never operate the engine of the towing vehicle in a closed building. The exhaust fumes may cause asphyxiation.

A fire extinguisher and first aid kit should be kept readily accessible while performing maintenance on this equipment.

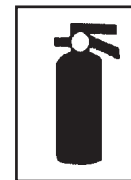

### STORAGE

- Lower equipment to the ground and block to prevent rolling.
- Keep playing children and bystanders away from storage area.
- Store on a level surface sheltered from the weather.



## 2.6 TRANSPORTING SAFETY

- ◆ Use a Slow-Moving-Vehicle (SMV) emblem and proper lighting on the tractor when transporting the trailer. **DO NOT** transport on public roads.
- ◆ **ALWAYS** comply with all state and local lighting and marking requirements.
- ◆ **DON'T** drive the tractor and trailer over 20 MPH (30 KPH) on the best surface conditions. Reduce speed when going up or down hills and when approaching ditches or corners.
- ◆ Check condition of hitch pins and bolts before transporting.
- ◆ Keep your trailer in proper working condition. Unauthorized modifications to the trailer may impair the function, affect the trailer life, and put you at risk. **DO NOT** add excessive weight to trailer. Additional weight could cause frame to fail resulting in loss of control of trailer/ tractor during transport.
- ◆ Watch low hanging Overhead Power Lines during transport. Avoid contact as this can cause serious injury or death.
- ◆ Plan your route to avoid heavy traffic.
- ◆ Do not drink and drive.
- ◆ Be a safe and courteous driver. Always yield to oncoming traffic in all situations, including narrow bridges, intersections, etc. Watch for traffic when operating near or crossing roadways.
- ◆ Turn into curves or go up or down hills only at a low speed and at a gradual steering angle. Make certain that at least 20% of the tractor's weight is on the front wheels to maintain safe stearage. Slow down on rough or uneven surfaces.
- ◆ Never allow riders on either tractor or machine.
- ◆ **DO NOT** overload your trailer. **NEVER** exceed the trailer capacity.

## 2.7 SAFETY DECALS



### ALWAYS REPLACE MISSING OR DAMAGED DECALS

Good safety requires that you familiarize yourself with the various safety signs, the type of warning and the area, or particular function related to that area, that requires your SAFETY AWARENESS. The following safety decals are located on your implement. Read them and follow their instructions. Keep all decals in place and legible. Replace worn or missing decals. Replacement safety decals are available through your dealer.



REMEMBER - If safety signs have been damaged, removed, become illegible or parts replaced without signs, new signs must be applied. New signs are available from your authorized dealer.

# 3 OPERATION INSTRUCTIONS

Your personal safety is a primary concern in the design and manufacture of our products. Our efforts to provide such equipment can be wiped out by a single careless act of an operator.

In addition to the design and configuration of equipment, hazard control and accident prevention are dependent upon the awareness, concern, prudence and proper training of personnel involved in the operation, transport, maintenance and storage of equipment.

It has been said "**The best safety device is an informed, careful operator.**" We ask you to be that kind of an operator.

The operator must be properly trained. Operators should be familiar with the dump trailer and tractor and all safety practices before starting operation. Read the safety information in section 2 of this manual.

This Dump Trailer is designed for normal farm usage. **Do not** overload your trailer.

Maintain your Dump Trailer with original repair parts to insure that it provides optimum performance.

## MODIFICATIONS

It is the policy of the manufacturer to improve its products whenever possible and practical. We reserve the right to make changes, improvements and modifications at any time without incurring the obligation to make such changes, improvements and modifications on any implement sold previously.

## 3.1 ASSEMBLY

### GENERAL

Your Dump Trailer is shipped fully assembled.

Your trailer is designed for performing jobs with little or no adjustment requirement.

### IMPORTANT

Check trailer tire pressure to ensure adequate weight carrying capability.

## BEFORE OPERATION

1. Tighten all loose hardware using the torque chart. Replace any missing hardware. On new machines, all hardware must be rechecked after first few hours of operation.
2. Replace any bent or broken parts.
3. Check trailer for signs of wear or damage. Replace if necessary. **See Maintenance Section.**
4. Do not forget to unlock the proper panel before dumping.
5. Read the **Safety Section** of this manual to be sure of all precautions.

## 3.2 ATTACHING

1. Back tractor to align hitch with drawbar.



### WARNING

Be sure bystanders are clear. Do not stand between implement and tractor. Shut off tractor and engage parking brake prior to dismounting.

2. Attach tractor to trailer with high strength drawbar pin. Secure with keeper.
3. Attach hydraulic hoses from trailer to tractor remote outlets.



### WARNING

Do not use bare hand to check for leaks. Hydraulic fluid under high pressure can penetrate skin and cause poisoning.

The hydraulic system of your Dump Trailer requires careful inspection along with the mechanical parts. Be sure to replace frayed, kinked, cracked or otherwise damaged hydraulic components. Just because it isn't leaking today doesn't mean that it will not fail tomorrow.

Fluid escaping from a very small hole can almost be invisible. Do not check for leaks with your hand. Escaping fluid under pressure can have sufficient force to penetrate skin causing serious personal injury or even death. Leaks can be detected by passing a piece of cardboard or wood over the suspected leak and looking for discoloration.



**If injured by escaping fluid, see a doctor at once.** Serious infection or reaction can develop if proper medical treatment is not administered immediately.

### 3.3 TRANSPORTING

Transport at no more than 20 MPH (30 KPH).

Use care when transporting on rough terrain.

**DO NOT** transport on public roads. Always have a slow moving vehicle (SMV) emblem mounted to the tractor such that it is visible from the rear.

**ALWAYS** comply with all state and local lighting and marking requirements.

Reduce speed when going up or down hills and when approaching ditches or corners.

Check condition of hitch pins and bolts before transporting.

Keep your trailer in proper working condition. Unauthorized modifications to the trailer may impair the function, affect the trailer life, and put you at risk. **DO NOT** add excessive weight to trailer. Additional weight could cause frame to fail resulting in loss of control of trailer/tractor during transport.

Watch low hanging Overhead Power Lines during transport. Avoid contact as this can cause serious injury or death.

Plan your route to avoid heavy traffic.

Do not drink and drive.

Be a safe and courteous driver. Always yield to oncoming traffic in all situations, including narrow bridges, intersections, etc. Watch for traffic when operating near or crossing roadways.

Turn into curves or go up or down hills only at a low speed and at a gradual steering angle. Make certain that at least 20% of the tractor's weight is on the front wheels to maintain safe steering. Slow down on rough or uneven surfaces.

**NEVER** allow riders on either tractor or trailer.

### 3.4 MAINTENANCE & LUBRICATION



#### WARNING

Do not perform any maintenance while tractor is running or when trailer is in motion.

Your Dump Trailer is designed for minimum maintenance. By taking a few minutes prior to beginning operations and performing the following maintenance check, you will insure improved performance and longer life of your trailer. Repair or replace any damaged parts before using the trailer.

- √ Check tire pressure **every 50 hours** of operation.
- √ Make sure tailgate is shut and latched.
- √ Check all bolts for tightness.
- √ Check hydraulic connections.
- √ Check ball joints and pins.

#### LUBRICATION

Lubricate all grease fittings **every 20 hours** of operation.

Lubricate panel hinges **every 20 hours** of operation.

Clean and re-pack wheel bearings **once a year**.

### 3.5 STORAGE

1. Clean all debris from trailer.
2. Store trailer on a level surface sheltered from the weather. Block to prevent rolling.
3. Keep all cylinder rods in retracted position.
4. Keep playing children and bystanders away from storage area.

## 4 SPECIFICATIONS

<b>MODEL</b>	<b><u>1.5T50x72</u></b>	<b><u>2.5T60x99</u></b>	<b><u>4T63x99</u></b>	<b><u>5T63x99</u></b>	<b><u>8T60x120</u></b>
Capacity - Ton:	1 1/2	2 1/2	4	5	8
Capacity:	35 cu. ft.	77 cu. ft.	2 1/2 cu. yd.	2 1/2 cu. yd.	3 1/2 cu. yd.
Dump:	Rear	Rear	3 Way	3 Way	Rear
Hitch:	Swivel	Swivel	Swivel	Swivel	Swivel
Axle:	Tandem	Tandem	Single	Tandem	Tandem
Tire Size:	18x8-1/2x8	23x10-1/2x12	11L - 15	11L - 15	11L - 15
No. of Tires:	4	4	2	4	4
Weight:	600 lbs.	1600 lbs.	1825 lbs.	1900 lbs.	2050 lbs.
Bed Width:	50"	60"	63"	63"	60"
Bed Length:	70"	94"	99"	99"	120"
Bed Height:	21"	30"	33"	33"	31"
Bed Floor:	12 GA.	3/16"	3/16"	3/16"	3/16"
Overall Width:	54"	64"	68"	66"	88"
Overall Length:	8' 6"	11' 8"	11' 6"	11' 6"	13' 8"
Overall Height:	34"	52"	61"	61"	61"
Dump Angle:	45°	45°	45°	45°	45°
Side Panel Height:	13"	14"	14"	14"	16"
Rear Panel Height:	14"	19"	18"	18"	24"
Front Panel Height:	13"	19"	18"	18"	24"
Tongue Jack:	Std.	Std.	Std.	Std.	Std.
Options:			Grain Gate	Grain Gate	Grain Gate

*Specifications Subject To Change Without Notice*

# 5 TRAILER COMPONENTS

## 5.1 1 1/2 TON TRAILER

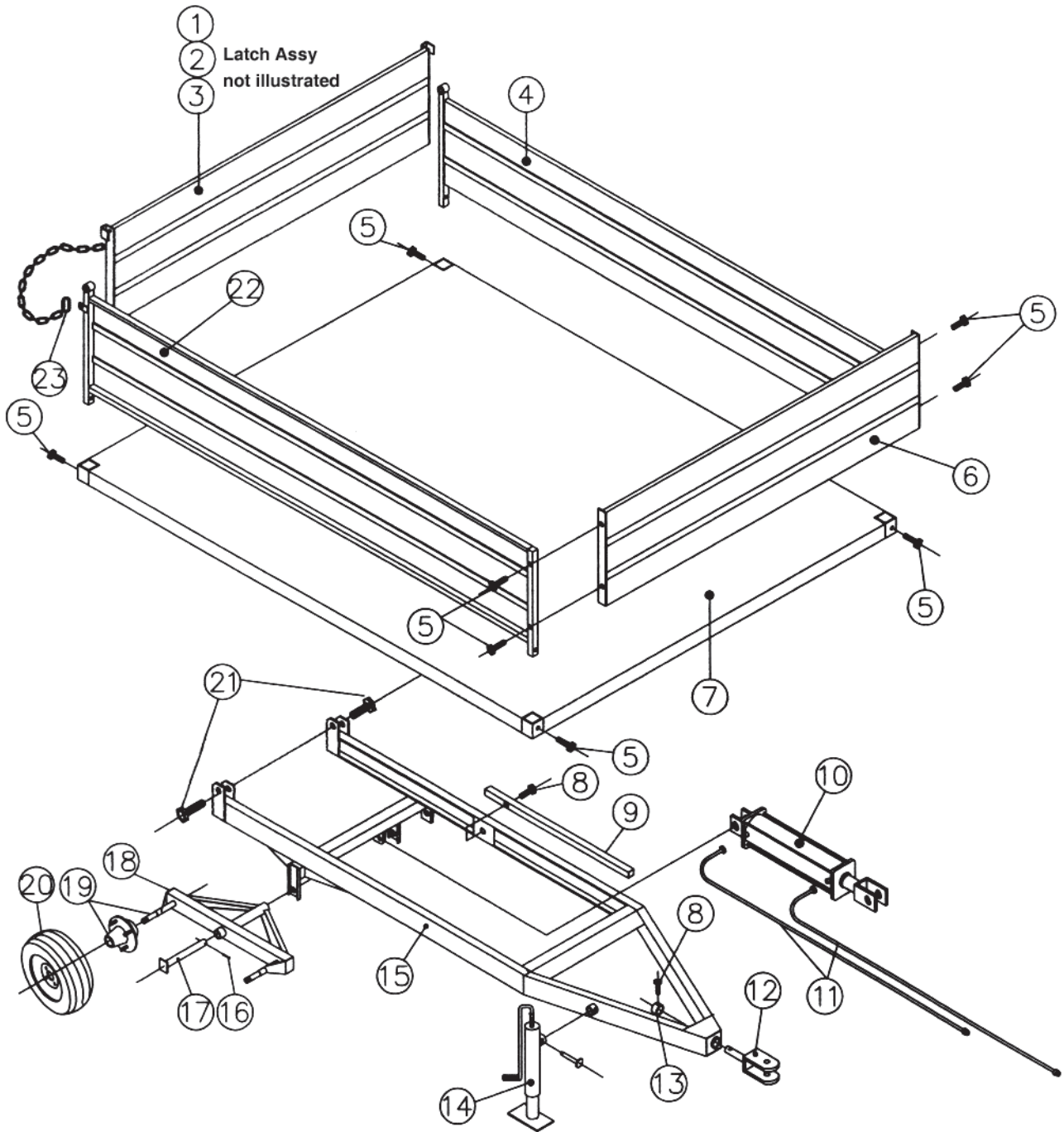

## 5.1 1 1/2 TON TRAILER

<u>REF #</u>	<u>QTY.</u>	<u>PART NO.</u>	<u>DESCRIPTION</u>
1	1	930419	Rear Box Panel
2	4	303611	HHCS $\frac{3}{8}$ x $\frac{3}{4}$ " Gr. 5
2	4	303969	Washer Flat $\frac{3}{8}$
3	2	930443	Rear Panel Latch
4	1	930412	Left Side Box Panel
5	8	303616	HHCS $\frac{3}{8}$ x 2" Gr. 5
5	8	304018	Nut/Hex Lock $\frac{3}{8}$ NC
6	1	930408	Front Box Panel
7	1	930404	Floor Assy.
8	2	303655	HHCS $\frac{1}{2}$ x 2 $\frac{1}{2}$ " Gr. 5
8	2	304020	Nut/Hex Lock $\frac{1}{2}$ NC
9	1	930427	Prop/Box
10	1	930470	Hydraulic Cylinder 3" x 12"
11	2	930466	Hydraulic Hose 102"
12	1	930445	Swivel Hitch
13	1	930567	Swivel Bushing
14	1	808009	10" Jack
15	1	930400	Trailer Main Frame
16	2	930548	Cotter Pin $\frac{5}{32}$ " x 3"
17	2	930437	King Pin
18	2	930434	Tandem Pivot Frame
19	4		Hub/Wheel Assembly (See page 20)
20	4		Tire/Wheel Assembly (See page 20)
21	2	303704	HHCS $\frac{3}{4}$ x 3 $\frac{1}{2}$ " Gr. 5
	2	304022	Nut/Hex Lock $\frac{3}{4}$ NC
22	1	930413	Right Side Box Panel
23	2	930444	Quick $\frac{3}{16}$ " Chain Link



## 5.2 2 1/2 TON TRAILER

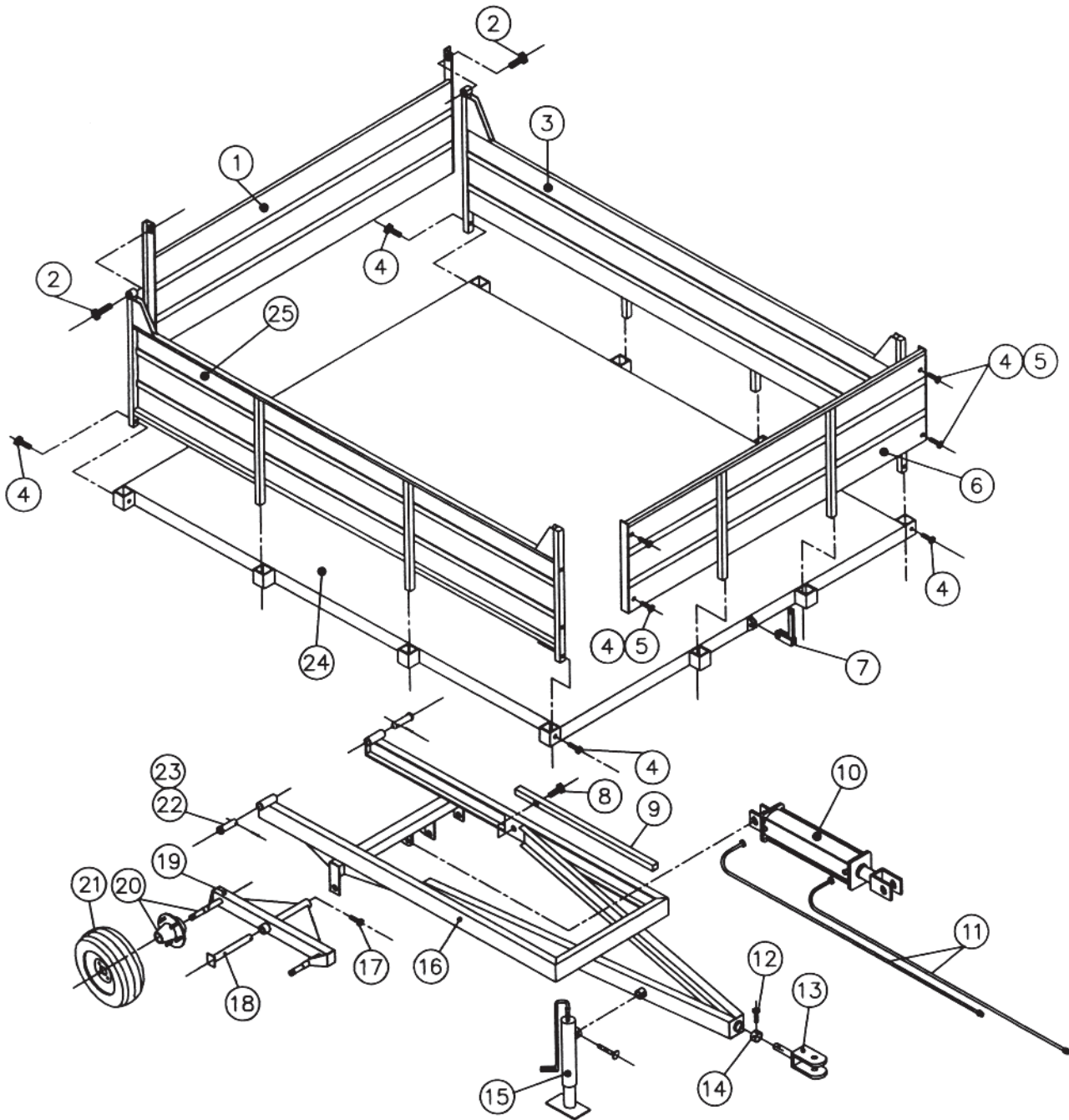

## 5.2 2 1/2 TON TRAILER

<u>REF #</u>	<u>QTY.</u>	<u>PART NO.</u>	<u>DESCRIPTION</u>
1	1	930420	Rear Panel
2	2	303706	HHCS 3/4 x 4 1/2" Gr. 5
2	2	304022	Hex Lock Nut 3/4 NC
3	1	930414	Left Panel
4	8	303618	HHCS 3/8 x 2 1/2" Gr. 5
4	8	304018	Hex Lock Nut 3/8 NC
5	4	303969	Flat Washer 3/8"
6	1	930409	Front Panel
7	1	930441	Latch Handle
8	1	303702	HHCS 3/4 x 2 3/4" Gr. 5
8	1	304022	Hex Lock Nut 3/4 NC
9	1	930428	Prop/Box
10	1	930469	Hydraulic Cylinder 2 1/2" x 20"
11	2	930570	Hydraulic Hose 102"
12	1	303655	HHCS 1/2 x 2 1/2" Gr. 5
12	1	304020	Hex Lock Nut 1/2 NC
13	1	930446	Swivel Hitch
14	1	930568	Swivel Bushing
15	1	808009	10" Jack
16	1	930401	Trailer Main Frame
17	2	303658	HHCS 1/2 x 3 1/2" Gr. 5
17	2	304020	Hex Lock Nut 1/2 NC
18	2	930438	King Pin
19	2	930435	Tandem Pivot Frame
20	4		Hub/Wheel Assy (See page 21)
21	4		Tire/Wheel Assy (See page 21)
22	2	930546	Bed Hinge Pin
23	2	304124	Cotter Pin 1/4 x 2"
24	1	930405	Floor Assy.
25	1	930415	Right Panel



### 5.3 4 TON TRAILER

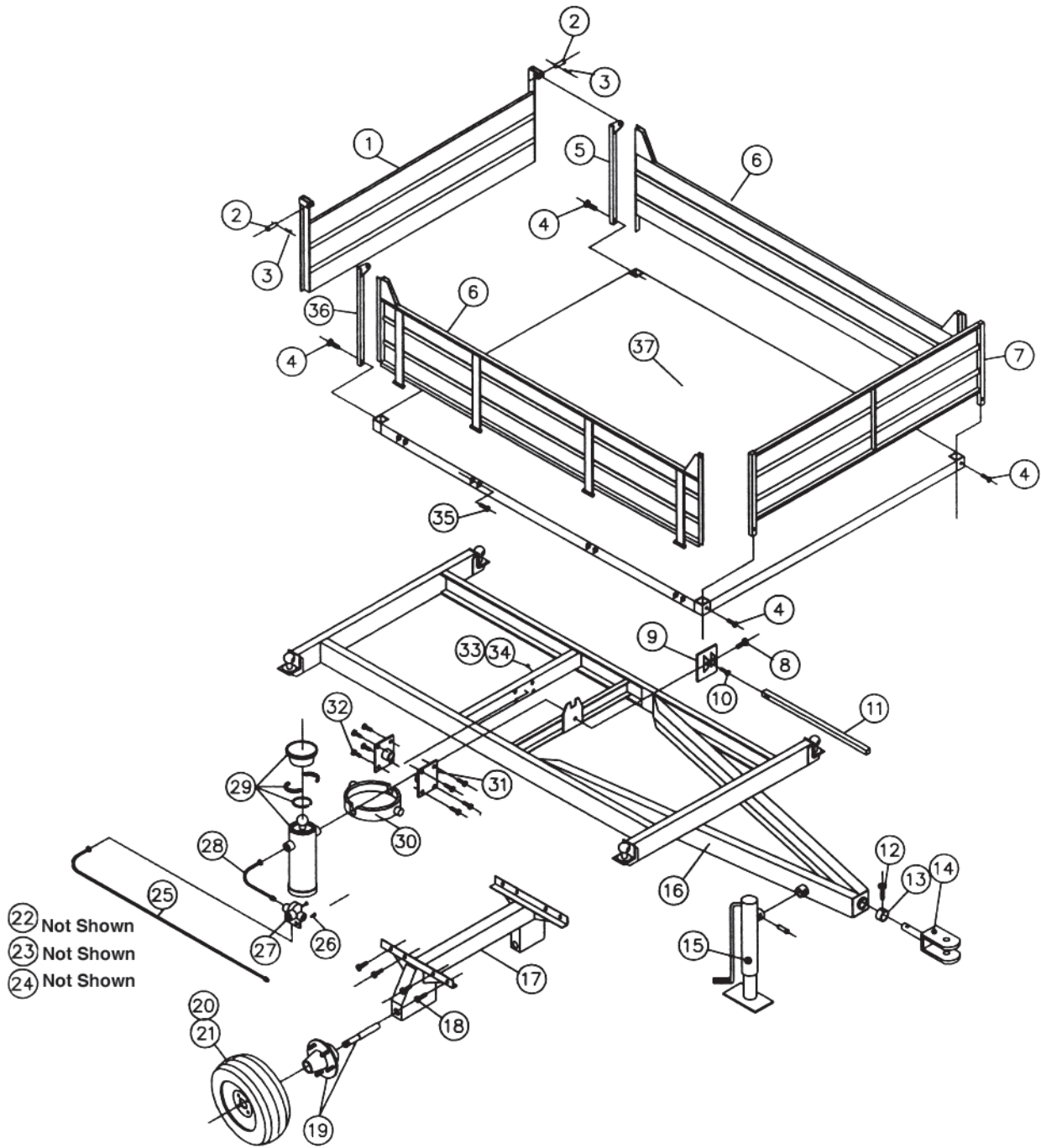

### 5.3 4 TON TRAILER

<u>REF #</u>	<u>QTY.</u>	<u>PART NO.</u>	<u>DESCRIPTION</u>
1	1	930421	Rear Panel
2	2	930547	Tailgate Hinge Pin
3	2	930548	Hairpin Cotter Pin <sup>5</sup> / <sub>32</sub> x 3"
4	4	303620	HHCS <sup>3</sup> / <sub>8</sub> x 3" Gr. 5
4	4	304018	Hex Lock Nut <sup>3</sup> / <sub>8</sub> NC
5	1	930422	Rear Left Hand Post
6	2	930416	Side Panel
7	1	930410	Front Panel
8	1	303657	HHCS <sup>1</sup> / <sub>2</sub> x 3" Gr. 5
8	1	304020	Hex Lock Nut <sup>1</sup> / <sub>2</sub> NC
9	1	930430	Swivel/Prop
10	1	303675	HHCS <sup>5</sup> / <sub>8</sub> x 1 <sup>3</sup> / <sub>4</sub> " Gr. 5
10	1	304021	Hex Lock Nut <sup>5</sup> / <sub>8</sub> NC
11	1	930429	Prop/Bed
12	1	303681	HHCS <sup>5</sup> / <sub>8</sub> x 3 <sup>1</sup> / <sub>2</sub> " NC
12	1	304021	Hex Lock Nut <sup>5</sup> / <sub>8</sub> NC
13	1	930569	Swivel Bushing
14	1	930447	Swivel Hitch
15	1	808009	10" Jack
16	1	930402	Trailer Main Frame
17	1	930432	Wheel Mount Beam
18	8	303651	HHCS <sup>1</sup> / <sub>2</sub> x 1 <sup>1</sup> / <sub>2</sub> " Gr. 5
18	8	304020	Hex Lock Nut <sup>1</sup> / <sub>2</sub> NC
19	2		Hub/Wheel Assy (See page 22)
20	2	208891	15 x 8 - 6 Bolt Rim
20	12	403817	Wheel Bolt
21	2	208899	11L - 15 - 8 Ply Tire
22	1	930549	Hairpin Cotter Pin <sup>3</sup> / <sub>16</sub> x 4"
23	2	930550	Tilt Pin <sup>3</sup> / <sub>4</sub> "
24	1	930551	Tailgate Latch Pin
25	1	930467	Hydraulic Hose 113"
26	3	303594	HHCS <sup>5</sup> / <sub>16</sub> x 1 <sup>1</sup> / <sub>4</sub> " Gr. 5
26	3	304017	Hex Lock Nut <sup>5</sup> / <sub>16</sub> NC
27	1	930474	Hydraulic Control Valve
27	1	930558	Hydraulic 90° Elbow Fitting
28	1	930464	Hydraulic Hose 22"
29		903473	Hydraulic Dump Cylinder - 3 Stage
30		903440	Cylinder Gimble
31	2	903426	Trunion Cylinder Mount
32	8	303651	HHCS <sup>1</sup> / <sub>2</sub> x 1 <sup>1</sup> / <sub>2</sub> " Gr. 5
32	8	304020	Hex Lock Nut <sup>1</sup> / <sub>2</sub> NC
33	2	930556	Cable Clamp <sup>1</sup> / <sub>8</sub> "
34	1	930557	Cable - <sup>1</sup> / <sub>8</sub> " x 72"
35	8	304020	HHCS <sup>1</sup> / <sub>2</sub> x 3" Gr. 5
35	8	304020	Hex Lock Nut <sup>1</sup> / <sub>2</sub> NC
36	1	930423	Rear Right Hand Post
37	1	930406	Floor Assy.

## 5.4 5 TON TRAILER

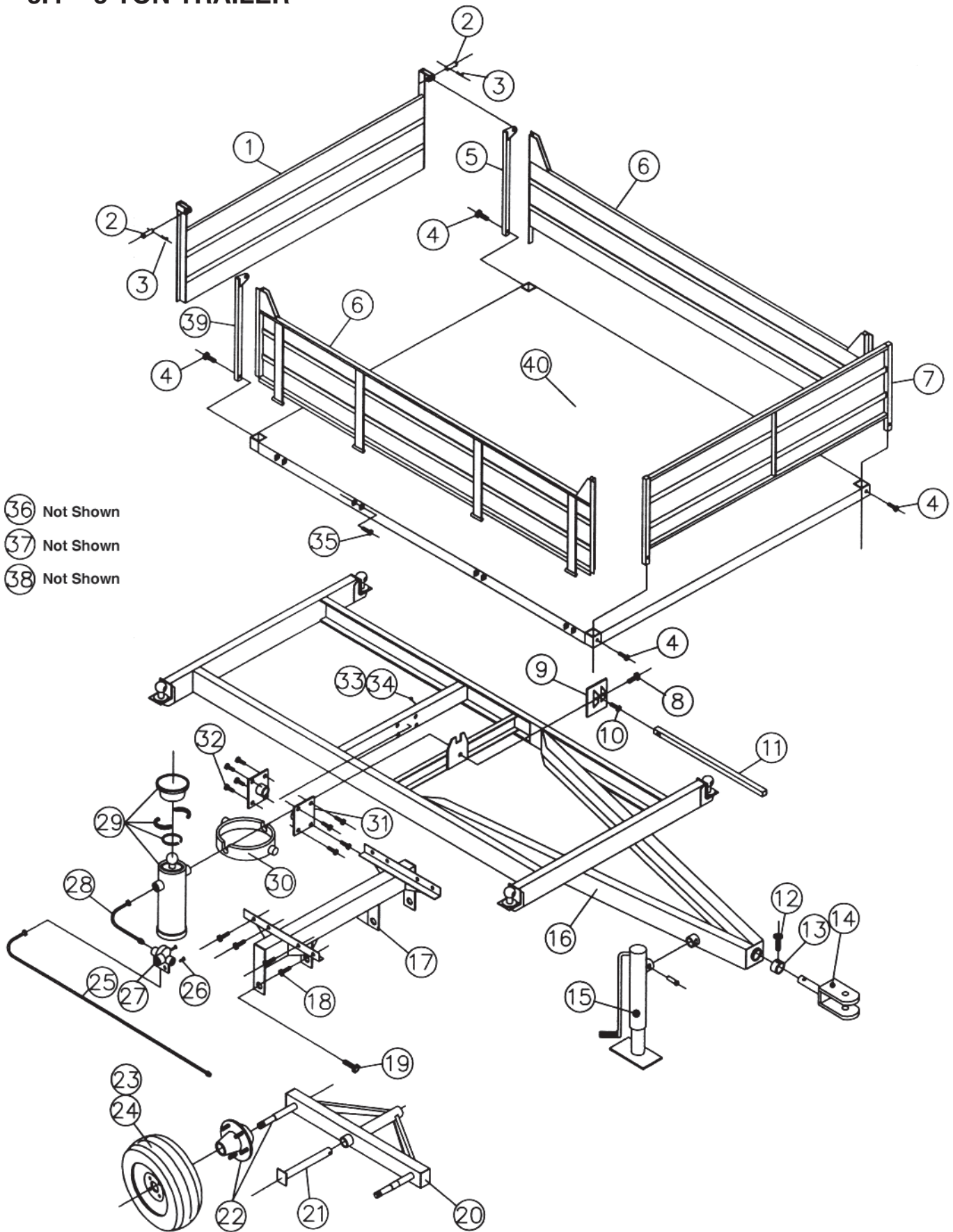

## 5.4 5 TON TRAILER

<u>REF #</u>	<u>QTY.</u>	<u>PART NO.</u>	<u>DESCRIPTION</u>
1	1	930421	Rear Panel
2	2	930547	Tailgate Hinge Pin
3	2	930548	Hairpin Cotter Pin $5/32 \times 3"$
4	4	303620	HHCS $3/8 \times 3"$ Gr. 5
4	4	304018	Hex Lock Nut $3/8$ NC
5	1	930422	Rear Left Hand Post
6	2	930416	Side Panel
7	1	930410	Front Panel
8	1	303657	HHCS $1/2 \times 3"$ Gr. 5
8	1	304020	Hex Lock Nut $1/2$ NC
9	1	930430	Swivel/Prop
10	1	303675	HHCS $5/8 \times 1 3/4"$ Gr. 5
10	1	304021	Hex Lock Nut $5/8$ NC
11	1	930429	Prop/Bed
12	1	303681	HHCS $5/8 \times 3 1/2"$ NC
12	1	304021	Hex Lock Nut $5/8$ NC
13	1	930569	Swivel Bushing
14	1	930447	Swivel Hitch
15	1	808009	10" Jack
16	1	930402	Trailer Main Frame
17	1	930433	Wheel Mount Beam
18	8	303651	HHCS $1/2 \times 1 1/2"$ Gr. 5
18	8	304020	Hex Lock Nut $1/2$ NC
19	2	303658	HHCS $1/2 \times 3 1/2"$ Gr. 5
19	2	304020	Hex Lock Nut $1/2$ NC
20	2	930436	Tandem Pivot Frame
21	2	930439	King Pin
22	2		Hub/Wheel Assy (See page 22)
23	2	208861	15 x 8 - 6 Bolt Rim
23	12	403817	Wheel Bolt
24	2	208899	11L - 15 - 8 Ply Tire
25	1	930467	Hydraulic Hose 113"
26	3	303594	HHCS $5/16 \times 1 1/4"$ Gr. 5
26	3	304017	Hex Lock Nut $5/16$ NC
27	1	930474	Hydraulic Control Valve
27	1	930558	Hydraulic 90° Elbow Fitting
28	1	930464	Hydraulic Hose 22"
29	1	930473	Hydraulic Dump Cylinder - 3 Stage
30	1	930440	Cylinder Gimble
31	2	930426	Trunion Cylinder Mount
32	8	303651	HHCS $1/2 \times 1 1/2"$ Gr. 5
32	8	304020	Hex Lock Nut $1/2$ NC
33	2	930556	Cable Clamp $1/8"$
34	1	930557	Cable $1/8" \times 72"$
35	8	303657	HHCS $1/2 \times 3"$ Gr. 5
35	8	304020	Hex Lock Nut $1/2$ NC
36	1	930549	Hairpin Cotter Pin $3/16 \times 4"$
37	2	930550	Tilt Pin $3/4"$
38	1	930551	Tailgate Latch Pin
39	1	930423	Rear Right Hand Post
40	1	930406	Floor Assy.

# 5.5 8 TON TRAILER

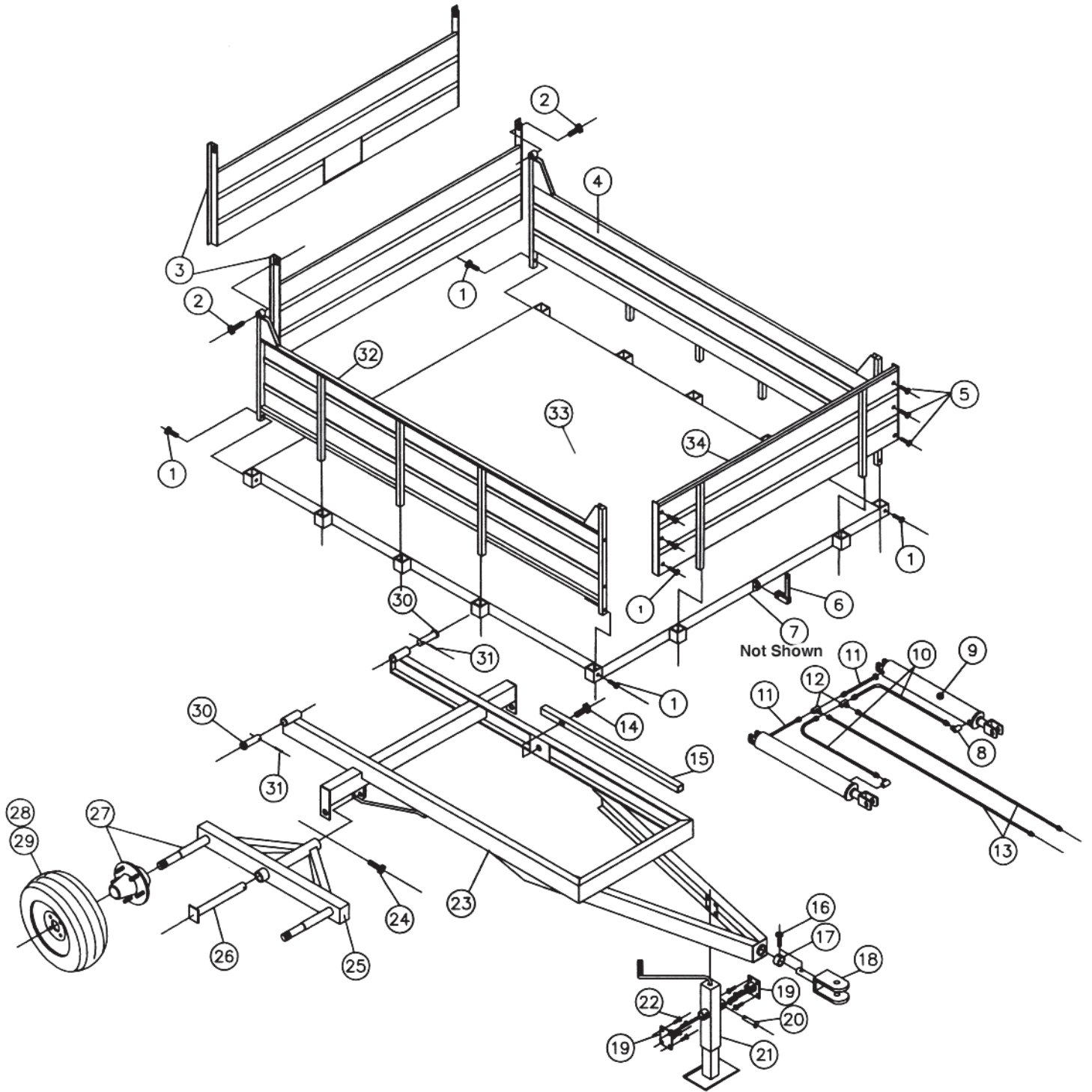

## 5.5 8 TON TRAILER

<u>REF #</u>	<u>QTY.</u>	<u>PART NO.</u>	<u>DESCRIPTION</u>
1	4	303620	HHCS $\frac{3}{8}$ x 3" Gr. 5
1	4	304018	Hex Lock Nut $\frac{3}{8}$ NC
2	2	303706	HHCS $\frac{3}{4}$ x 4 $\frac{1}{2}$ " Gr. 5
2	2	304022	Hex Lock Nut $\frac{3}{4}$ NC
3	1	930424	Rear Panel Assy.
3	1	930425	Rear Panel Assy. - Grain
4	1	930417	Left Side Panel
5	6	303619	HHCS $\frac{3}{8}$ x 2 $\frac{3}{4}$ " Gr. 5
5	6	304018	Hex Lock Nut $\frac{3}{8}$ NC
6	1	930441	Latch Assy.
7	2	930555	Clevis Pin Kit $\frac{7}{16}$ x 1 $\frac{5}{8}$ "
8	2	930559	90° Hydraulic Swivel Adapter
9	2	930471	Hydraulic Cylinder 3 x 30" or
9	2	930472	Hydraulic Cylinder 3 $\frac{1}{2}$ x 30"
10	2	930465	Hydraulic Hose 45"
11	2	930463	Hydraulic Hose 16"
12	2	930560	Hydraulic Swivel Tee $\frac{3}{8}$ x $\frac{3}{8}$ x $\frac{3}{8}$
13	2	930468	Hydraulic Hose 158"
14	1	303680	HHCS $\frac{5}{8}$ x 3" Gr. 5
14	1	304021	Hex Lock Nut $\frac{5}{8}$
15	1	930431	Prop/Bed
16	1	303681	HHCS $\frac{5}{8}$ x 3 $\frac{1}{2}$ " Gr. 5
16	1	304021	Hex Lock Nut $\frac{5}{8}$ NC
17	1	930569	Swivel Bushing
18	1	930447	Swivel Hitch
19	2	930553	Mount/ Jack Assy.
20	1		Jack Pin
21	1	930554	7000# Jack
22	8	303651	HHCS $\frac{1}{2}$ x 1 $\frac{1}{2}$ " Gr. 5
22	8	304020	Hex Lock Nut $\frac{1}{2}$ NC
23	1	930403	Trailer Main Frame
24	2	303658	HHCS $\frac{1}{2}$ x 3 $\frac{1}{2}$ " Gr. 5
24	2	304020	Hex Lock Nut $\frac{1}{2}$ NC
25	2	930436	Tandem Pivot Frame
26	2	930440	King Pin
27	4		Hub/Wheel Assy (See page 22)
28	4	208861	Rim 15 x 8 - 6 Bolt
28	24	403817	Wheel Bolt
29	4	208899	11L - 15 - 8 Ply Tire
30	2	930552	Hinge Pin
31	2	304126	Cotter Pin $\frac{1}{4}$ x 2 $\frac{1}{2}$ "
32	1	930418	Right Side Panel
33	1	930407	Floor Assy.
34	1	930411	Front Panel



## 5.6 1 1/2 TON TIRE & WHEEL HUB COMPONENTS

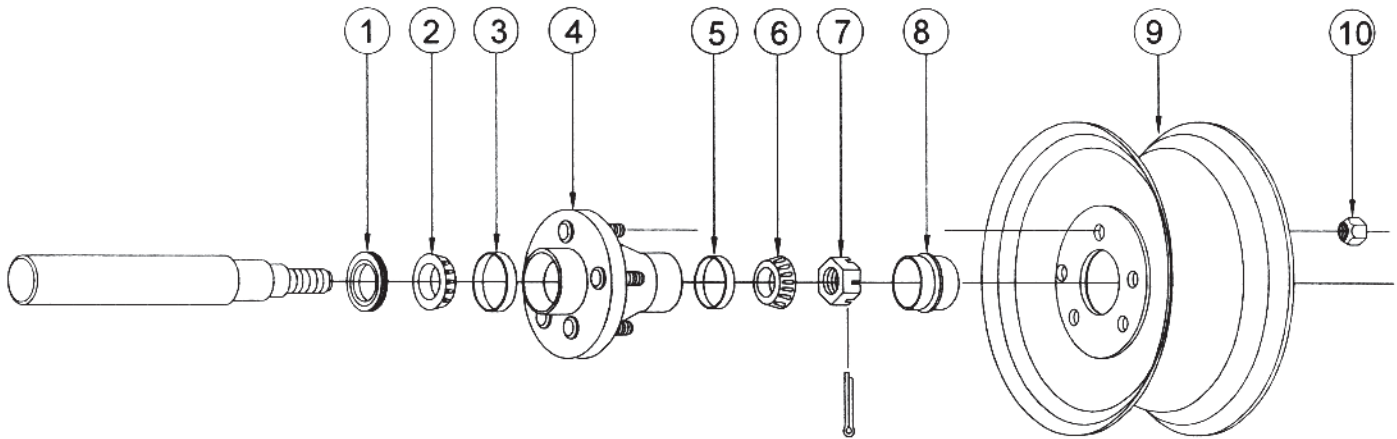

<u>REF #</u>	<u>QTY.</u>	<u>PART NO.</u>	<u>DESCRIPTION</u>
1	1	930460	Triple Lip Seal
2	1	814684	Bearing Cone L44643
3	1	505282	Bearing Cup L44610
4	1	930452	Wheel Hub - 4 Bolt
5	1	505282	Bearing Cup L44610
6	1	814684	Bearing Cone L44643
7	1	930561	Hex Slotted Nut
7	1	930562	Cotter Pin
8	1	930455	Hub Cap
9	1	930448	Wheel Rim 8.5 x 8 - 4 Bolt
10	5	050843	Lug Nut 1/2" UNF
		930450	Tire 8.5 x 8 Turf Saver Pr (not shown)

## 5.7 2 1/2 TON TIRE & WHEEL HUB COMPONENTS

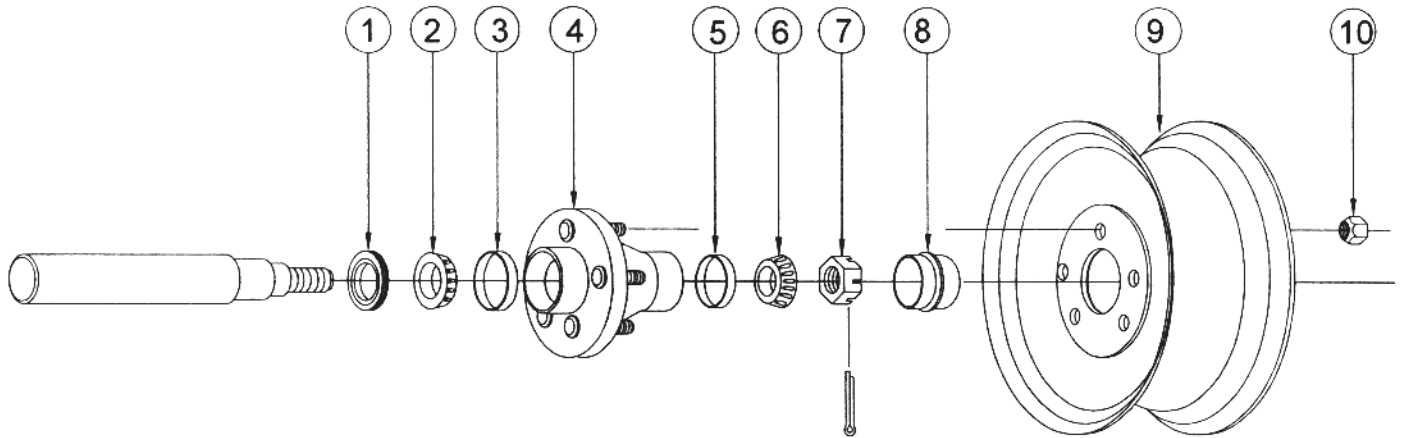

<u>REF #</u>	<u>QTY.</u>	<u>PART NO.</u>	<u>DESCRIPTION</u>
1	1	930461	Triple Lip Seal
2	1	930458	Bearing Cone L68149
3	1	930459	Bearing Cup L68111
4	1	930453	Wheel Hub - 5 Bolt
5	1	505282	Bearing Cup L44610
6	1	930457	Bearing Cone L44649
7	1	930561	Hex Slotted Nut
7	1	930566	Flat Washer
7	1	930562	Cotter Pin
8	1	930455	Hub Cap
9	1	930449	Wheel Rim 12 x 8.5 x 5 - 5 Bolt
10	5	403817	Wheel Bolt 1/2" UNF
	1	930451	Tire 23 x 10 1/2 x 12 - 4 Ply (not shown) Turf Saver
		930571	Tire & Rim Assy 23 x 10 1/2 x 12 - 4 Ply Turf Saver



## 5.8 4, 5 & 8 TON TIRE & WHEEL HUB COMPONENTS

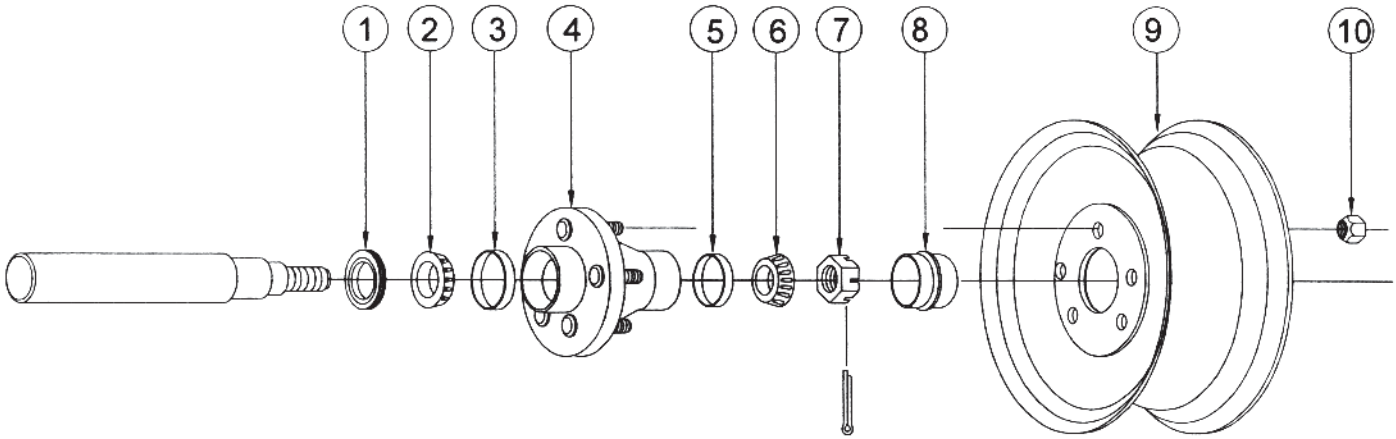

<u>REF #</u>	<u>QTY.</u>	<u>PART NO.</u>	<u>DESCRIPTION</u>
1	1	930462	Triple Lip Seal
2	1	211440	Bearing Cone LM501349
3	1	211441	Bearing Cup LM501310
4	1	930454	Wheel Hub - 6 Bolt
5	1	206332	Bearing Cup LM67010
6	1	811199	Bearing Cone LM67048
7	1	930562	Hex Slotted Nut
7	1	930564	Flat Washer
7	1	930565	Cotter Pin
8	1	930456	Hub Cap
9	1	208861	Wheel Rim 15 x 8 - 5 Bolt
10	6	403817	Lug Nut 1/2" UNF
	1	208899	Tire 11L - 15 - 8 Ply Pr (not shown)

## 5.9 1 1/2 TON HYDRAULIC CYLINDER COMPONENTS

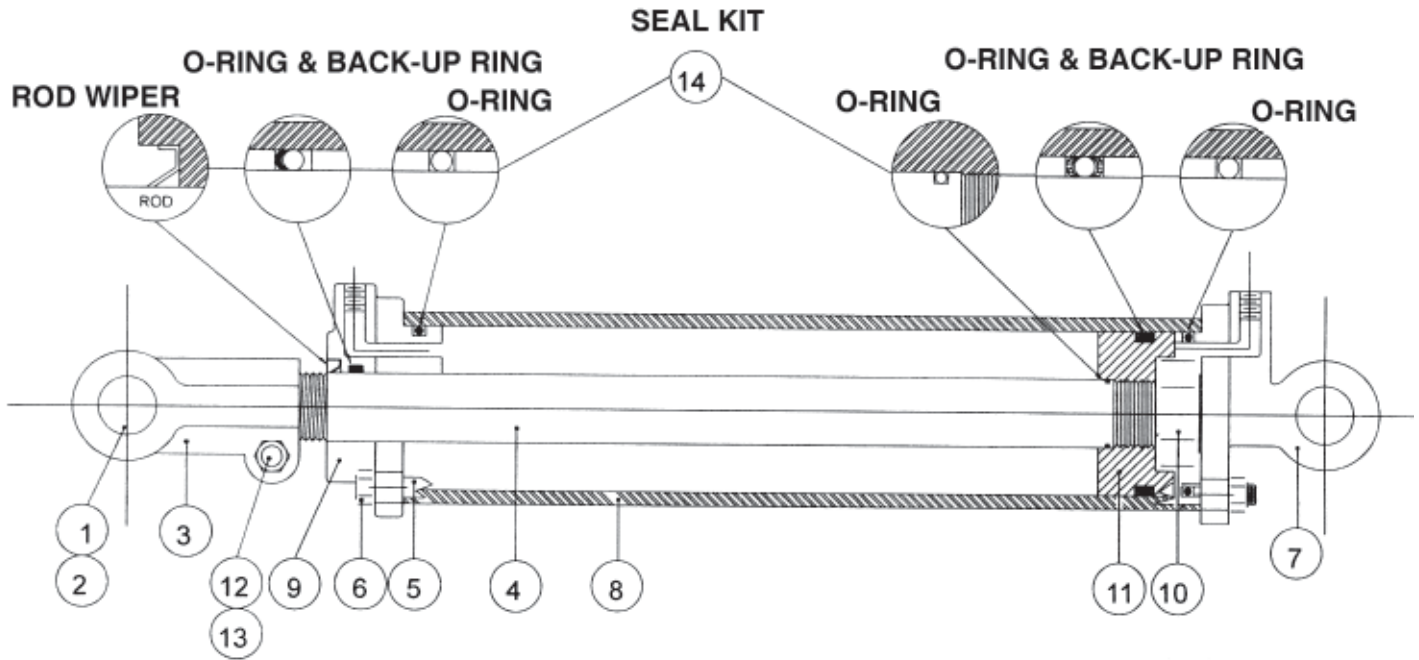

"This Cylinder is Tie Rod Design with Square Ends"

<u>REF #</u>	<u>QTY.</u>	<u>PART NO.</u>	<u>DESCRIPTION</u>
1	4	304244	Hairpin Clip
2	2	606949	Clevis Pin
3	1	930476	Clevis Assembly 3 x 12"
4	1	930477	Rod
5	4	930478	Tie Rod 3 x 12"
6	8	930479	Tie Rod Nut
7	1	930480	Base End
8	1	930481	Barrel Tube 3 x 12"
9	1	930482	Rod End Gland (Cap)
10	1	930483	Piston Nut
11	1	930484	Piston
12	1	930485	Clevis Nut
13	1	930486	Clevis Bolt
14	1	930487	Packing Kit - 3 x 12" Cylinder
		930470	Complete Cylinder 3 x 12"

## 5.10 2 1/2 TON HYDRAULIC CYLINDER COMPONENTS

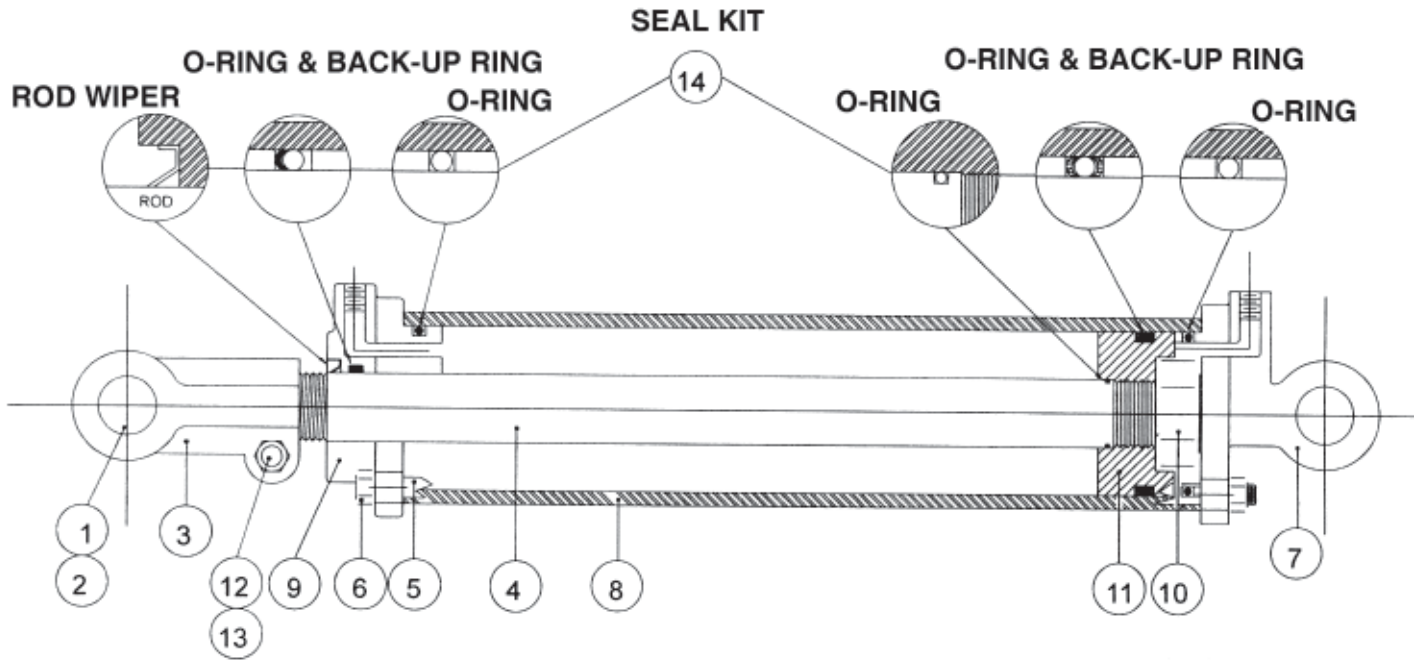

"This Cylinder is Tie Rod Design with Square Ends"

<u>REF #</u>	<u>QTY.</u>	<u>PART NO.</u>	<u>DESCRIPTION</u>
1	4	304244	Hairpin Clip
2	2	606949	Clevis Pin
3	1	930488	Clevis Assembly 2 1/2 x 20"
4	1	930489	Rod
5	4	930490	Tie Rod 2 1/2 x 20"
6	8	930491	Tie Rod Nut
7	1	930492	Base End
8	1	930493	Barrel Tube 2 1/2 x 20"
9	1	930494	Rod End Gland (Cap)
10	1	930495	Piston Nut
11	1	930496	Piston
12	1	930485	Clevis Nut
13	1	930486	Clevis Bolt
14	1	930487	Packing Kit - 2 1/2 x 20" Cylinder
		930469	Complete Cylinder 2 1/2 x 20"

## 5.11 4 & 5 TON HYDRAULIC CYLINDER COMPONENTS

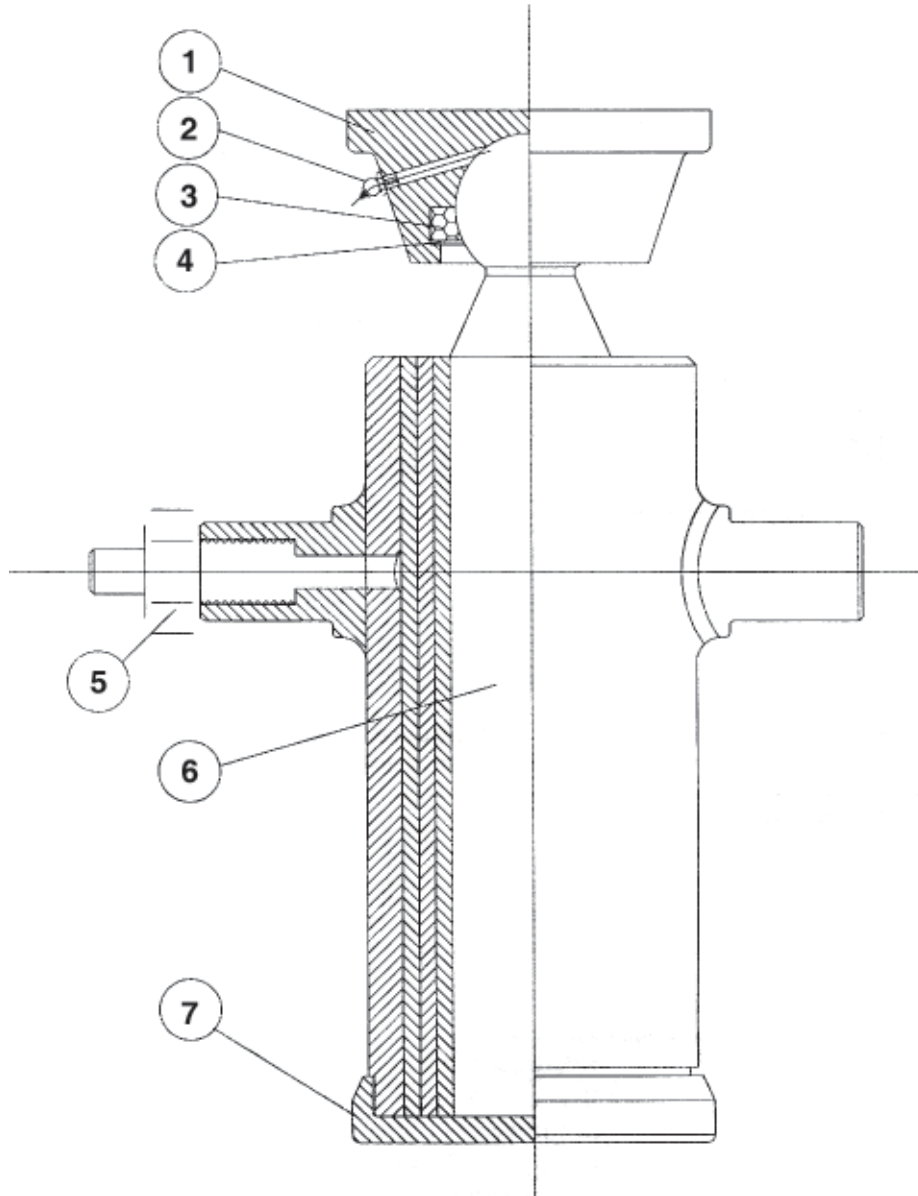

<u>REF #</u>	<u>QTY.</u>	<u>PART NO.</u>	<u>DESCRIPTION</u>
1	1	930512	BallJoint Mount
2	1		Grease Fitting $\frac{1}{4}$ - 28 - 45°
3	1	930513	Locking Segment For Ball Joint
4	1	930514	Retaining Ring
5	1	930515	Hydraulic Connector
6	1	930516	Outer Housing
7	1	930517	Threaded Cap
8	1	930518	Packing Repair Kit
9	1	930519	Seal Repair Kit
		930473	Lift Hydraulic Cylinder

## 5.12 4 & 5 TON HYDRAULIC VALVE COMPONENTS

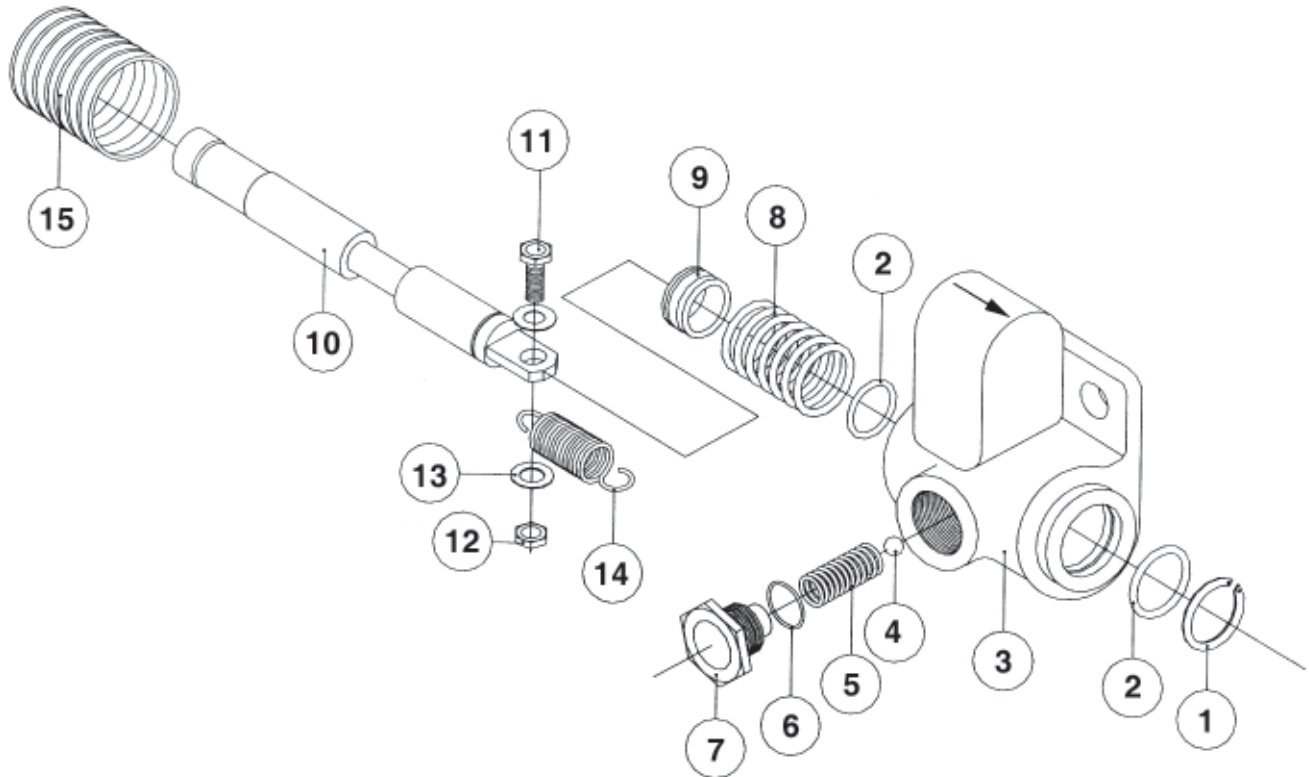

<u>REF #</u>	<u>QTY.</u>	<u>PART NO.</u>	<u>DESCRIPTION</u>
1	1	930520	Snap Ring
2	1	**	O-Ring
3	1	930522	Valve Body
4	1	930523	Steel Ball
5	1	930524	Compression Spring
6	1	**	O-Ring
7	1	930526	Adjustment Plug
8	1	930527	Compression Spring
9	1	**	Seal
10	1	930529	Valve Spool
11	1	305204	HHCS 8mm x 25mm
12	1	305681	Hex Lock Nut 8mm
13	2	303968	Flat Washer 8mm
14	1	930530	Extension Spring
15	1	930531	Bellows
**	1	930532	Seal Repair Kit (includes ref. #2, 6 & 9)
		930474	Hydraulic Control Valve

## 5.13 8 TON HYDRAULIC CYLINDER COMPONENTS

### 3" BORE - HYDRAULIC CYLINDER - 3 x 30"

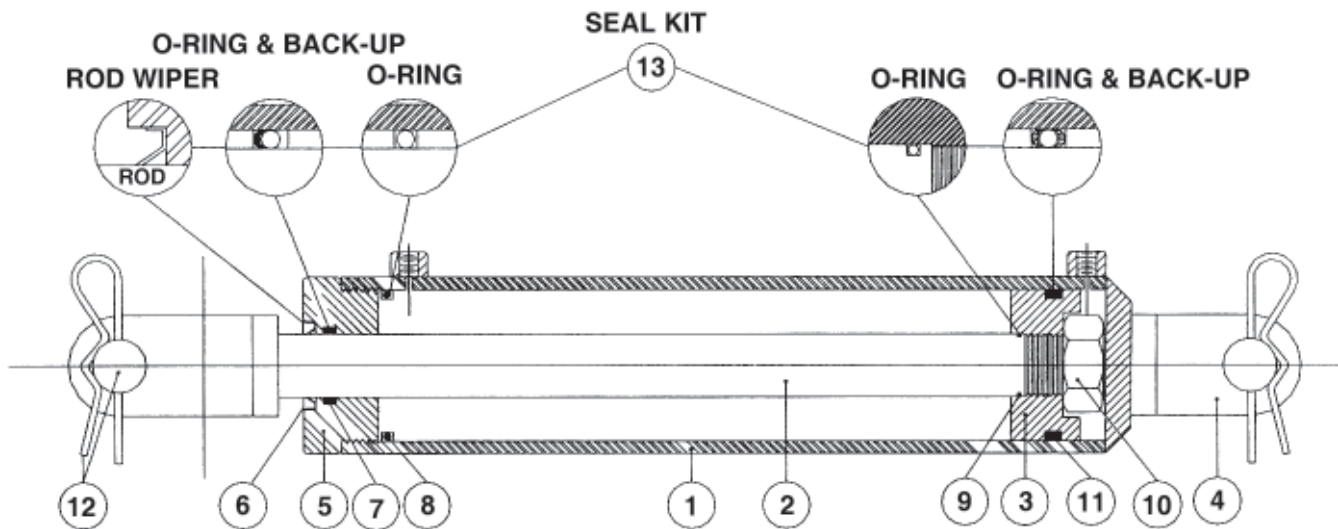

"This Cylinder is Round Barrel - Non Tie Rod Design"

<u>REF #</u>	<u>QTY.</u>	<u>PART NO.</u>	<u>DESCRIPTION</u>
1	1	930498	Tube & Ports
2	1	930499	Rod & Clevis
3	1	930500	Piston
4	1	930501	Base & Clevis
5	1	930502	Head & Gland
6	1	**	Rod Wiper
7	1	**	Rod Seal
8	1	**	Gland Seal
9	1	**	O-Ring
10	1	930503	Piston Nut
11	1	**	Piston Seal
12	2		Pins & Clips
13	1	930504	Seal Kit (includes Ref. #6, 7, 8, 9 & 11)
	4	304244	Hairpin Clip
	2	606949	Clevis Pin
		930471	Lift Hydraulic Cylinder 3 x 30"

## 5.13 8 TON HYDRAULIC CYLINDER COMPONENTS

3 1/2" BORE - HYDRAULIC CYLINDER - 3 1/2 x 30"

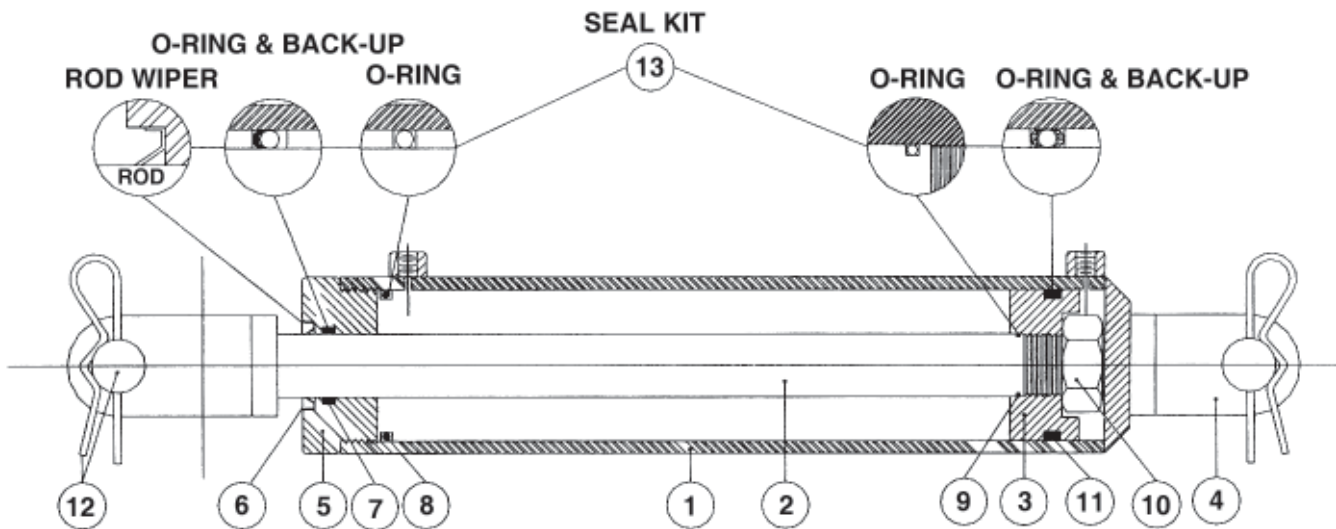

"This Cylinder is Round Barrel - Non Tie Rod Design"

<u>REF #</u>	<u>QTY.</u>	<u>PART NO.</u>	<u>DESCRIPTION</u>
1	1	930506	Tube & Ports
2	1	930506	Rod & Clevis
3	1	930507	Piston
4	1	930508	Base & Clevis
5	1	930509	Head & Gland
6	1	**	Rod Wiper
7	1	**	Rod Seal
8	1	**	Gland Seal
9	1	**	O-Ring
10	1	930510	Piston Nut
11	1	**	Piston Seal
12	2		Pins & Clips
13	1	930511	Seal Kit (includes Ref. #6, 7, 8, 9 & 11)
	4	304244	Hairpin Clip
	2	606949	Clevis Pin
		930472	Lift Hydraulic Cylinder 3 1/2 x 30"

## 5.14 8 TON HYDRAULIC COMPONENTS

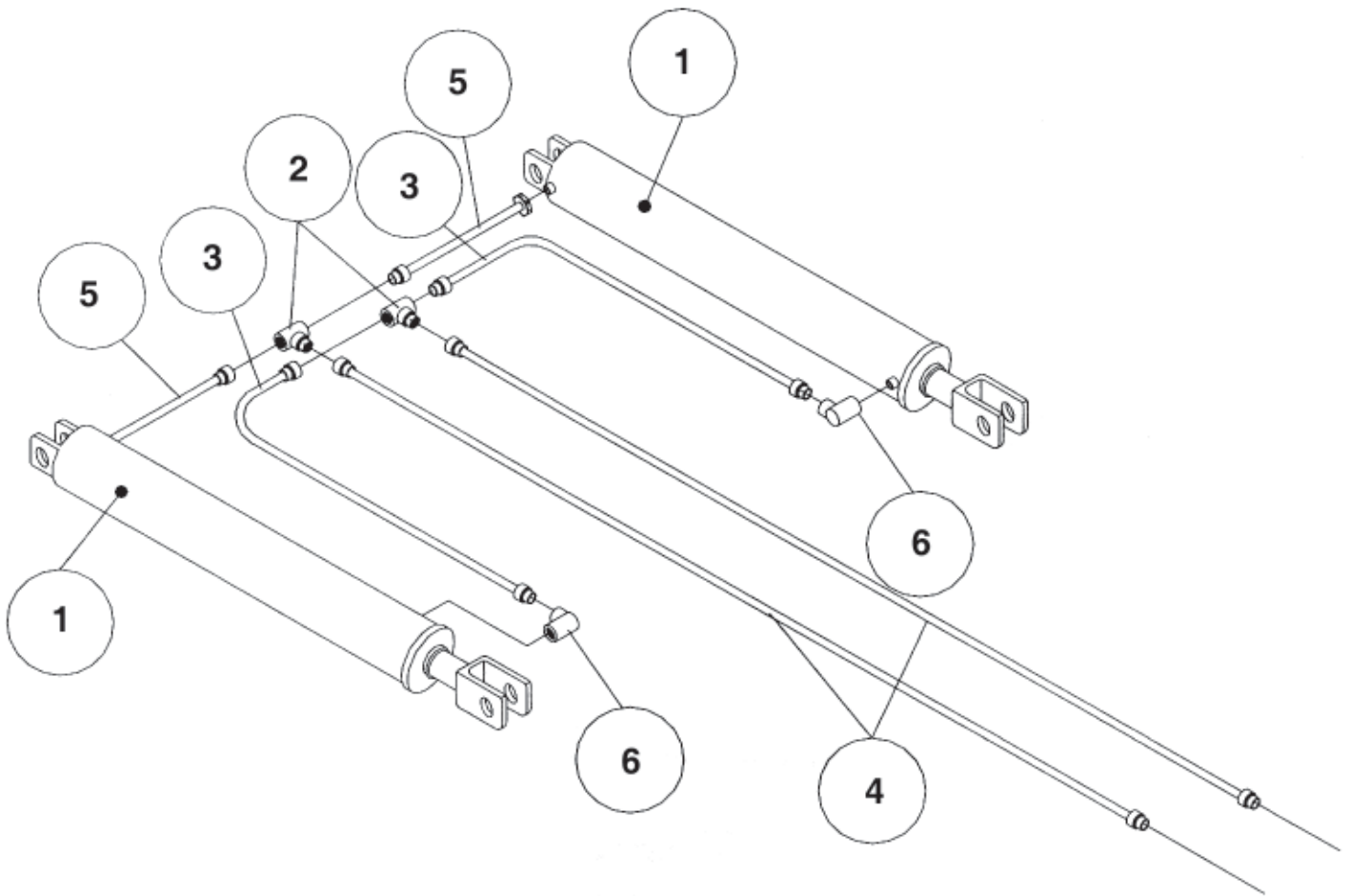

<u>REF #</u>	<u>QTY.</u>	<u>PART NO.</u>	<u>DESCRIPTION</u>
1	2	930471	Hydraulic Cylinder 3 x 30"
1	2	930472	Hydraulic Cylinder 3 1/2 x 30"
2	2	930560	Hydraulic Swivel Tee 3/8 x 3/8 x 3/8
3	2	930465	Hydraulic Hose 45"
4	2	930468	Hydraulic Hose 158"
5	2	930463	Hydraulic Hose 16"
6	2	930559	Hydraulic 90° Swivel O-Ring



## 5.15 MANUAL HYDRAULIC PUMP COMPONENTS

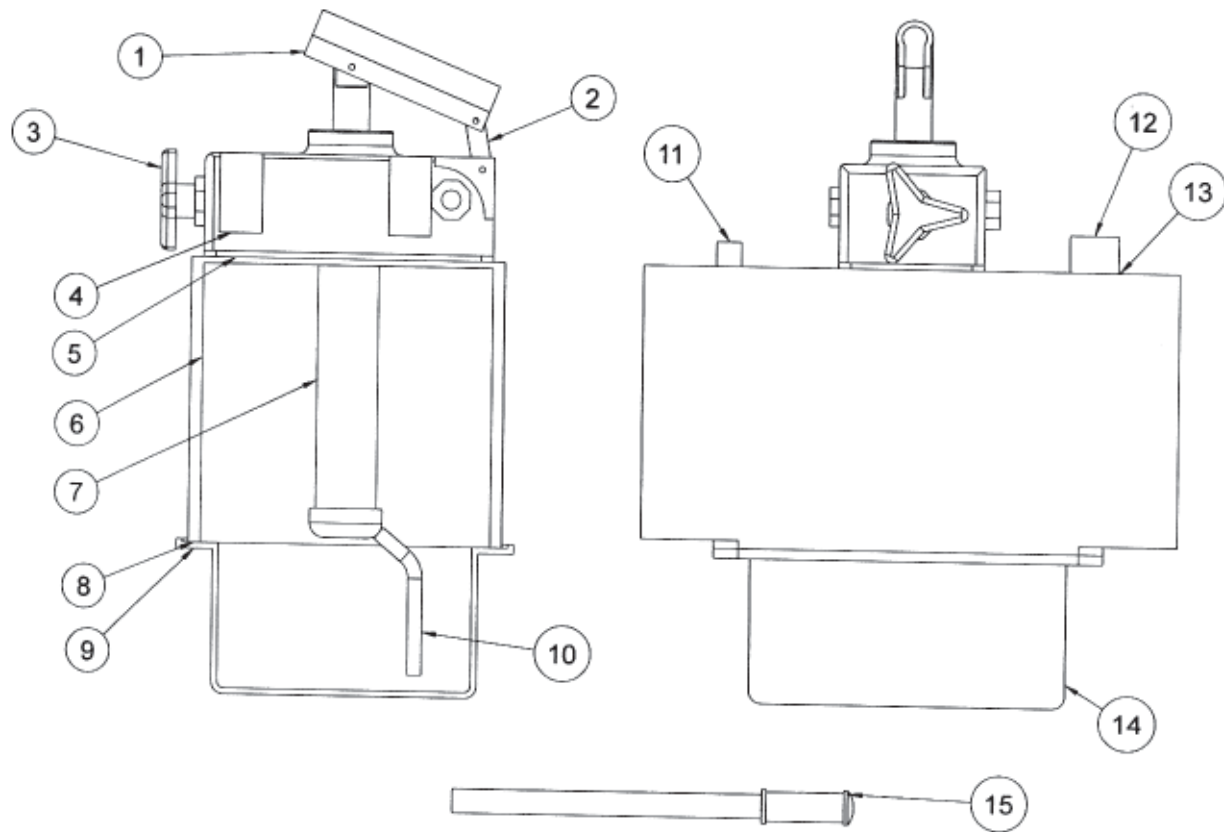

<u>REF #</u>	<u>QTY.</u>	<u>PART NO.</u>	<u>DESCRIPTION</u>
1			Not Serviced
2			Not Serviced
3	1	930533	Relief Valve Knob
4	4	305204	HHCS M8 x 25
5	1	930534	Pump Gasket
6	1	930535	Main Body Pump
7	1	930536	Hand Pump Only (no body)
8	1	930537	Reservoir Gasket
9	8	930538	Screw for Reservoir Mounting
10	1	930539	Suction Tube for 3 Liter Reservoir
11	1	930540	Oil Filler Plug
12	1	930541	Breather Cap
13	1	930542	Aluminum Washer
14	1	930543	3 Liter Reservoir
15	1	930544	Handle Lever
***	1	930545	Gasket Kit
		930475	Manual Hydraulic Pump

## 6 LIMITED WARRANTY



GEARMORE, INC., warrants each new Gearmore product to be free from defects in material and workmanship for a period of twelve (12) months from date of purchase to the original purchaser. This warranty shall not apply to implements or parts that have been subject to misuse, negligence, accident, or that have been altered in any way.

Our obligation shall be limited to repairing or replacement of any part, provided that such part is returned within thirty (30) days from date of failure to Gearmore through the dealer from whom the purchase was made, transportation charges prepaid.

This warranty shall not be interpreted to render us liable for injury or damages of any kind or nature, direct, consequential or contingent, to person or property. This warranty does not extend to loss of crops, loss because of delay in harvesting or any other expenses, for any other reasons.

Gearmore in no way warrants engines, tires, or other trade accessories, since these items are warranted separately by these respective manufacturers.

Gearmore reserves the right to make improvements in design or changes in specification at any time, without incurring any obligations to owners or units previously sold.

GEARMORE, INC.  
13477 Benson Ave.  
Chino, CA 91710

Always refer to and heed machine operating warning decals on machine.

*The serial number of this product is stored in our computer database, thus submitting a warranty registration card is not required.*