

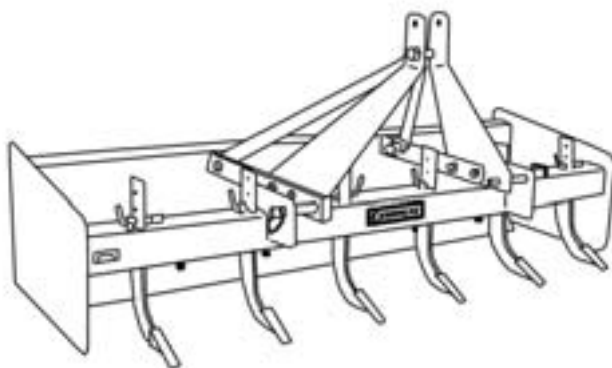

# BOX SCRAPERS



**Operation, Service  
& Parts Manual  
For Models:  
BB30-60, BB30-66,  
BB30-72, & BB30-84**

**September 2006**

# TABLE OF CONTENTS

Introduction .....	1
Safety Precautions .....	2 - 3
Federal Laws & Regulations .....	4
Tractor Operating Instructions .....	5
Operation Instructions .....	6
Attachment to Tractor .....	6
Detaching from Tractor .....	6
Operation .....	6
Transportation .....	7
Maintenance .....	7
Maintenance Safety .....	7
Torque Specifications .....	8
Parts Drawing .....	9
Parts List .....	10
Retail Customer's Warranty Responsibility ...	11
Manufacturer's Limited Warranty .....	12

Date of Purchase: \_\_\_\_\_

Model Number: \_\_\_\_\_

Serial Number \_\_\_\_\_

# INTRODUCTION

*We welcome you as an owner of a Gearmore box scraper. Please read the following instructions and refer to them when required.*

## TRAINING

With normal maintenance you should receive years of use out of the box scraper.

1. Safety instructions are important! Read this manual, the tractor manual and all safety rules.
2. Know your controls and how to stop tractor engine quickly in an emergency.
3. Operators **must** be instructed in and be capable of the safe operation of the equipment, its attachments and all controls. **Do not** allow anyone to operate this equipment without proper instructions.
4. **Do not** allow children or unqualified persons to operate equipment

## PREPARATION

1. **Always** wear relatively tight and belted clothing to avoid entanglement in moving parts. Wear sturdy, rough-soled work shoes and protective equipment for eyes, hands, hearing and head.
2. Ensure box scraper is properly mounted, adjusted and in good operating condition and that all fasteners are torqued to the specifications given in the *Torque Chart*.
3. Ensure all safety decals are installed and in good condition.
4. A minimum 20% of tractor and equipment weight **must** be on tractor from wheels with box scraper in transport position. Without this weight, tractor could tip over causing personal injury or death. The weight may be attained with front wheel weights, ballast in tires or front tractor weights. When attaining the minimum 20% weight on the front wheels, you **must not** exceed the Roll Over Protection Structure (ROPS) weight certification. Weigh tractor and equipment. **Do not** guess or estimate.

# IMPORTANT SAFETY PRECAUTIONS



Know your controls and how to stop tractor engine and box scraper quickly in an emergency. ***READ THIS OPERATOR'S MANUAL AND THE MANUAL PROVIDED WITH YOUR TRACTOR.***



In addition to the design and configuration of equipment, hazard control and accident prevention are dependent upon the awareness, concern, prudence and proper training of personnel in the operation, transport, maintenance, and storage of equipment. Lack of attention to safety can result in accident, personal injury, reduction of efficiency and worst of all - loss of life. Watch for safety hazards and correct deficiencies promptly. Use the following safety precautions as a general guide to safe operations when using this machine. Additional safety precautions are used throughout this manual for specific operating and maintenance procedures. Read this manual and review the safety precautions often until you know the limitations.

1. Read the Operator's Manual. Failure to read the Operator's Manual is considered a misuse of this equipment.
2. Become familiar with all the machine's controls and all the caution, warning and danger decals affixed to the machine before attempting to start or operate.
3. Before starting or operating the machine, make a walk around inspection and check for obvious defects such as loose mounting bolts and damaged components. Correct any deficiency before starting.
4. **DO NOT** allow children to operate the implement. Do not allow adults to operate implement without proper instruction.
5. Do not carry passengers.
6. Keep the area of operation clear of all persons, particularly small children and pets. The operator should cease operation whenever anyone comes within the area.
7. Lower implement to ground, stop tractor engine, remove the key, and apply parking brake before leaving the tractor.
8. Keep hands and feet away from implement.
9. Wear personal protective equipment such as, but not limited to, protection for eyes, ears, feet, hands, and head, when operating or repairing the equipment. Do not wear loose clothing or jewelry that may catch on equipment moving parts.

# IMPORTANT SAFETY PRECAUTIONS

10. When performing adjustments or maintenance on the implement, first lower it to the ground or block it securely at a workable height.
11. Never stand between tractor and implement while tractor is being backed to the hitch.
12. Reduce speed when transporting implement to avoid bouncing and momentary loss of steering.
13. Use tractor flashing warning lights, day or night, when transporting implement on road or highways unless prohibited by law.
14. It is recommended that tractor be equipped with Rollover Protective System (ROPS) and seat belt be used in all implement operations.
15. Make sure area behind your tractor is clear before operating in reverse.
16. *Do not* operate on steep slopes.
17. *Do not* stop, start or change directions suddenly on slopes.
18. Use *extreme* care and reduce ground speed on slopes and rough terrain.
19. Watch for hidden hazards on the terrain during operation.
20. Keep alert and watch ahead as well as behind the tractor when working with the box scraper.
21. Ensure equipment is properly mounted to tractor before making adjustments.
22. *Always* be sure the box scraper is in the fully raised position when in transport.
23. When turning close to buildings or passing through narrow areas, be sure to allow sufficient clearance for the box scraper.
24. Lower box scraper to ground, stop engine, set parking brake and remove key before dismounting tractor.

# FEDERAL LAWS & REGULATIONS

## IMPORTANT FEDERAL LAWS AND REGULATIONS\* CONCERNING EMPLOYERS, EMPLOYEES, AND OPERATIONS

\*(This section is intended to explain in broad terms the concept and effect of the following federal laws and regulations. It is not intended as a legal interpretation of the laws and should not be considered as such.)

U.S. Public Law 91-596 (The Williams-Steiger Occupational and Health Act of 1970) OSHA

### **This Act Seeks:**

"...to assure so far as possible every working man and woman in the nation safe and healthful working conditions and to preserve our human resources..."

### **DUTIES**

Sec. 5 (a) Each employer -

- (1) shall furnish to each of his employees employment and a place of employment which are free from recognized hazards that are causing or are likely to cause death or serious physical harm to his employees;
  - (2) shall comply with occupational safety and health standards promulgated under this act.
- (b) Each employee shall comply with occupational safety and health standards and all rules, regulations and orders issued pursuant to this Act which are applicable to his own actions and conduct.

### **OSHA Regulations**

Current OSHA regulations state in part: "At the time of initial assignment and at least annually thereafter, the employer shall instruct every employee in the safe operation and servicing of all equipment with which the employee is, or will be involved." These will include (but are not limited to) instructions to:

Keep all guards in place when the machine is in operation.

Permit no riders on equipment.

Stop engine, disconnect the power source, and wait for all machine movement to stop before servicing, adjusting, cleaning, or unclogging the equipment, except where the machine must be running to be properly serviced or maintained, in which case the employer shall instruct employees as to all steps and procedures which are necessary to safely service or maintain the equipment.

Make sure everyone is clear of machinery before starting the engine, engaging power, or operating the machine.

### **Child Labor Under 16 Years Old**

Some regulations specify that no one under the age of 16 may operate power machinery. It is your responsibility to know what these regulations are in your own area or situation. (Refer to U.S. Department of Labor, Employment Standard Administration, Wage & Home Division, Child Labor Bulletin #102.)

# TRACTOR OPERATING INSTRUCTIONS

1. Read and understand the manual provided with your tractor.
2. Know your controls and how to stop your tractor in an emergency.



3. Securely fasten your seat belt if the tractor has a ROPS.

4. Where possible, avoid operating the tractor near ditches, embankments, and holes.

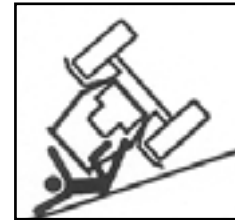

5. Reduce speed when turning, crossing slopes, and on rough, slick, or muddy surfaces.

6. Stay off slopes too steep for safe operation.

7. Watch where you are going, especially at row ends, on roads, and around trees.

8. **Do Not** permit others to ride on tractor or box scraper.

9. Operate the tractor smoothly - no jerky turns, starts, or stops.

10. Hitch only to the drawbar and hitch points recommended by tractor manufacturers.

11. When tractor is stopped, or before making any repairs or adjustments, set brakes securely, use parking brake if available, and remove key.



**NOTE:** Because the manufacturer maintains an ongoing program of product improvement, we reserve the right to make improvements in design or changes in specifications without incurring any obligation to install them on units previously sold. Because of the possibility that some photographs in this manual were taken of prototype models, production models may vary in some detail. In addition, some photographs may show shields removed for purposes of clarity. **NEVER OPERATE** this implement without all shields in place.

# OPERATING INSTRUCTIONS



**DURING BLADE ADJUSTMENT KEEP BODY, HANDS,  
AND FEET CLEAR OF BLADE.**

## **ATTACHMENT TO TRACTOR:**

The box blade should be placed on level ground. Place the tractor 3-point lift arm control in "position control" (non-floating) for attaching and detaching the rear mounted blade. "Draft control" or "position control" can be used while operating.

Attach the top link to the top hitch mount and adjust so that the blade frame will be level in the operating position.

Back the tractor until the ends of the lift arms can be attached to the bottom clevis pins on the implement. Secure the lift arms to the clevis pins.

## **DETACHMENT FROM TRACTOR:**

Lower the blade to the ground with the 3-point lift arm control in "position control".

Remove top link from top hitch mount, disconnect hitch arms from bottom clevis pins and pull tractor away from blade.

## **OPERATION:**

***Lower the implement as much as possible and securely support before making any adjustment.***

Level the box blade from side to side and front to rear using adjustments on the tractor's 3-point lift.

To adjust the scarifier shanks, first remove the pins holding the shanks in place. Slide the shanks up or down to desired position and replace the pins. The scarifiers should be adjusted to the lowest position to penetrate and break up the surface when moving large volumes of soil.

When leveling, the tips should be positioned to barely chip the surface, and when smoothing, the tips should completely clear the ground.

Care should be exercised during use of the box blade to prevent hanging the scarifier points or the blades on immovable objects or otherwise use the implement under conditions beyond its designed capacity.



# TRANSPORTATION & MAINTENANCE

## **TRANSPORTATION:**

When equipment is transported, use necessary devices required by local regulations for adequate warning to operators of other vehicles.

## **MAINTENANCE:**

1. Inspect your box scraper periodically and replace any worn or broken parts in order to have it ready for use when needed.
2. Lower box scraper to ground, turn tractor engine off and remove key before performing any service or maintenance.
3. Block box scraper securely before working underneath.
4. Keep all blade nuts and bolts tightened to 175 ft./lbs.
5. Blades can be reversed to use opposite cutting edge when needed.
6. Worn scarifier tips may be replaced by grinding or torching off the old tips and welding on replacements.
7. Keep all persons away from operator control area while performing adjustments, service or maintenance.
8. Periodically tighten all bolts, nuts and screws to ensure blade is in a safe condition.
9. Ensure all safety decals are installed and in good condition.
10. Store the box blade out of the weather when it is not in use. This helps prevent rusting of the blades and other components.

## **CUTTING EDGE:**

For reversing the cutting edge, remove plow bolts. Remove the cutting edge from moldboard and reinstall with the sharp edge down. Replace it when both edges are worn.

## **BOLTS:**

Keep all the bolts tight at all times by checking them periodically. Replace the bolts only with those having the same marks on the heads as on original bolt. Marks on bolt head indicate high strength.

# TORQUE SPECIFICATIONS

## PROPER TORQUE FOR AMERICAN FASTENERS USED ON BOX SCRAPERS

WRENCH SIZE	BOLT AND THREAD SIZE	SAE GRADE 2	SAE GRADE 5	SAE GRADE 8
7/16	1/4 - 20 UNC	6 (7)	8 (11)	12 (16)
7/16	1/4 - 28 UNF	6 (8)	10 (13)	14 (18)
1/2	5/16 - 18 UNC	11 (15)	17 (23)	25 (33)
1/2	5/16 - 24 UNF	13 (17)	19 (26)	27 (37)
9/16	3/8 - 16 UNC	20 (27)	31 (42)	44 (60)
9/16	3/8 - 24 UNF	23 (31)	35 (47)	49 (66)
5/8	7/16 - 14 UNC	32 (43)	49 (66)	70 (95)
5/8	7/16 - 20 UNF	36 (49)	55 (75)	78 (106)
3/4	1/2 - 13 UNC	49 (66)	76 (103)	106 (144)
3/4	1/2 - 20 UNF	55 (75)	85 (115)	120 (163)
7/8	9/16 - 12 UNC	70 (95)	109 (148)	153 (207)
7/8	9/16 - 18 UNF	79 (107)	122 (165)	172 (233)
15/16	5/8 - 11 UNC	97 (131)	150 (203)	212 (287)
15/16	5/8 - 18 UNF	110 (149)	170 (230)	240 (325)
1-1/8	3/4 - 10 UNC	144 (195)	266 (360)	376 (509)
1-1/8	3/4 - 16 UNF	192 (260)	297 (402)	420 (569)
1-5/16	7/8 - 9 UNC	166 (225)	430 (583)	606 (821)
1-5/16	7/8 - 14 UNF	184 (249)	474 (642)	668 (905)
1-1/2	1 - 8 UNC	250 (339)	644 (873)	909 (1232)
1-1/2	1 - 12 UNF	274 (371)	705 (955)	995 (1348)
1-1/2	1 - 14 UNF	280 (379)	721 (977)	1019 (1381)
1-11/16	1-1/8 - 7 UNC	354 (480)	795 (1077)	1288 (1745)
1-11/16	1-1/8 - 12 UNF	397 (538)	890 (1206)	1444 (1957)
1-7/8	1-1/4 - 7 UNC	500 (678)	1120 (1518)	1817 (2462)
1-7/8	1-1/4 - 12 UNF	553 (749)	1241 (1682)	2013 (2728)
2-1/16	1-3/8 - 6 UNC	655 (887)	1470 (1992)	2382 (3228)
2-1/16	1-3/8 - 12 UNF	746 (1011)	1672 (2266)	2712 (3675)
2-1/4	1-1/2 - 6 UNC	870 (1179)	1950 (2642)	3161 (4283)
2-1/4	1-1/2 - 12 UNF	979 (1327)	2194 (2973)	3557 (4820)

Recommended Torque in Foot Pounds (Newton Meters)

Use 75% of specified value for plated fasteners.

Use 85% of specified value for lubricated fasteners.

# BOX SCRAPER PARTS DRAWING

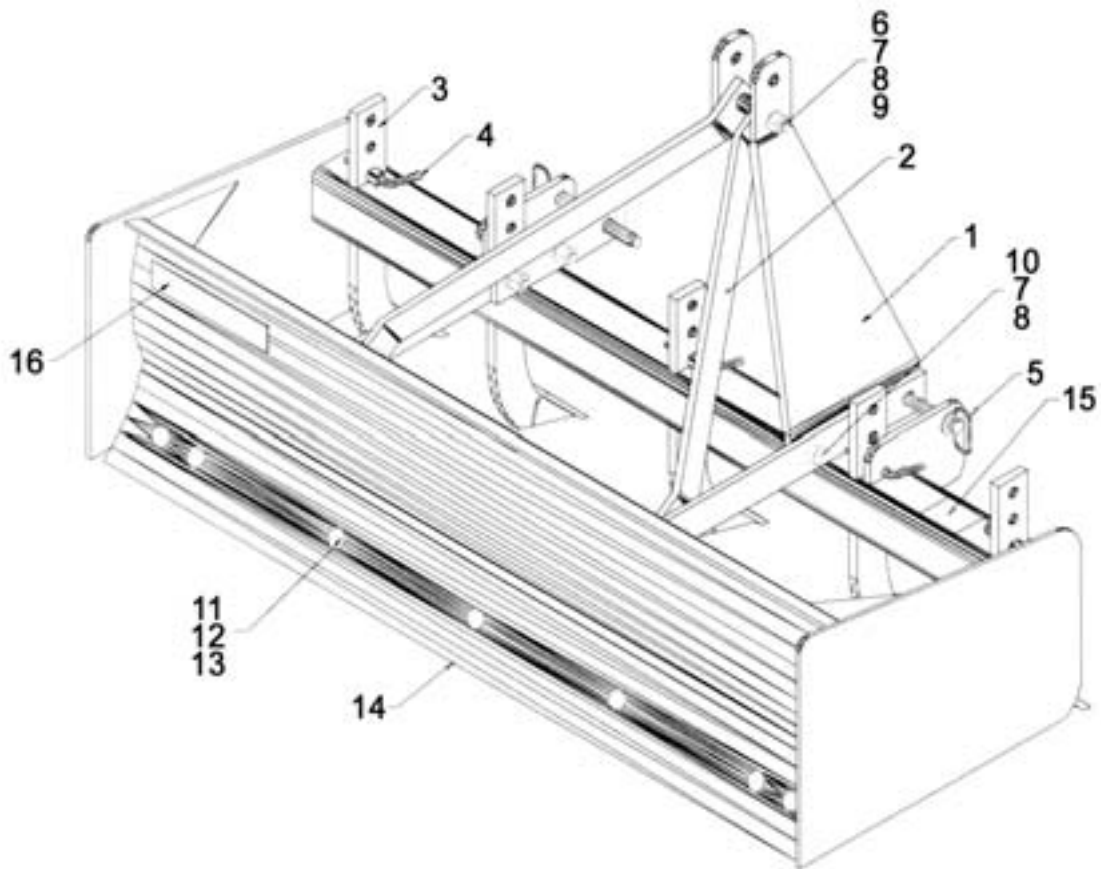

# BOX SCRAPER PARTS DRAWING

<u>REF #</u>	<u>PART NO.</u>	<u>DESCRIPTION</u>
1	BB30-00-09(L/R)	Top Link Mount
2	BB30-00-08	Top Link Brace
3	VSCAR	Scarifier Shank
4	VPINO.5000X5.000	1/2 x 3" Pin
5	VPINO.875X4.25	7/8" Clevis Pin
6	VHBO.750X5.00NCP	3/4" x 5" Grade 5 Bolt
7	VHNO.7500NCP	3/4" Hex Nut
8	VLWO.7500	3/4" Lock Washer
9	BB30-00-11	Top Link Spacer
10	VHBO.750X2.00NCP	3/4" x 2" Grade 5 Bolt
11	VPBO.625X1.75NCB	5/8" Plow Bolt
12	VHNO.6250NCP	5/8" Hex Nut
13	VLWO.6250	5/8" Lock Washer
14	VBE006001	60" Cutting Edge
14	VBE007201	72" Cutting Edge
14	VBE008401	84" Cutting Edge
15	VLBLWARNBB	Warning Label
16	VLBLBB3060	Product Label 60"
16	VLBLBB3072	Product Label 72"
16	VLBLBB3084	Product Label 84"

# CUSTOMER WARRANTY RESPONSIBILITY

It is the Retail Customer and/or Operator's responsibility to read the Operator's Manual, to operate, lubricate, maintain, and store the product in accordance with all instructions and safety procedures. Failure of the operator to read the Operator's Manual is a misuse of this equipment. It is the Retail Customer and/or Operator's responsibility to inspect the product and to have any part(s) repaired or replaced when continued operation would cause damage or excessive wear to other parts or cause a safety hazard, It is the Retail Customer's responsibility to deliver the product to the authorized dealer, from whom he purchased it, for service or replacement of defective parts which are covered by warranty. Repairs to be submitted for warranty consideration must be made within thirty (30) days of failure. It is the Retail Customer's responsibility for any cost incurred by the dealer for traveling to or hauling of the product for the purpose of performing a warranty obligation or inspection.

# LIMITED WARRANTY



GEARMORE, INC., warrants each new Gearmore product to be free from defects in material and workmanship for a period of twelve (12) months from date of purchase to the original purchaser. This warranty shall not apply to implements or parts that have been subject to misuse, negligence, accident, or that have been altered in any way.

Our obligation shall be limited to repairing or replacement of any part, provided that such part is returned within thirty (30) days from date of failure to Gearmore through the dealer from whom the purchase was made, transportation charges prepaid.

This warranty shall not be interpreted to render us liable for injury or damages of any kind or nature, direct, consequential or contingent, to person or property. This warranty does not extend to loss of crops, loss because of delay in harvesting or any other expenses, for any other reasons.

Gearmore in no way warrants engines, tires, or other trade accessories, since these items are warranted separately by these respective manufacturers.

Gearmore reserves the right to make improvements in design or changes in specification at any time, without incurring any obligations to owners or units previously sold.

GEARMORE, INC.  
13477 Benson Ave.  
Chino, CA 91710

Always refer to and heed machine operating warning decals on machine.

*The serial number of this product is stored in our computer database, thus submitting a warranty registration card is not required.*