



# 3509 & 3511 BACKHOE 3-POINT HITCH / CATEGORY II PARTS MANUAL



**PALADIN**  
LIGHT CONSTRUCTION GROUP



*The Power of Combined Excellence*

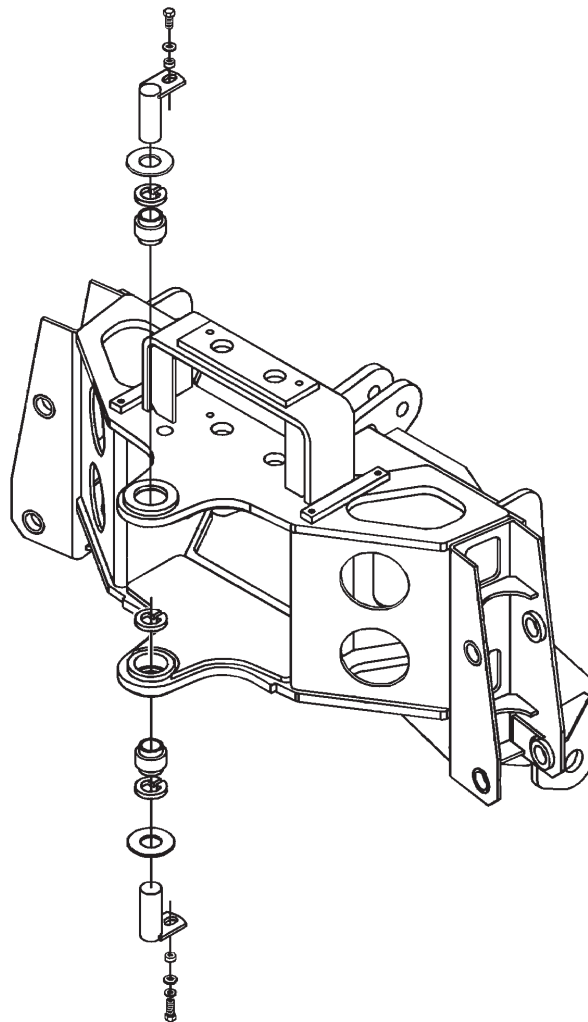

SERIAL NUMBER: \_\_\_\_\_

MODEL NUMBER: \_\_\_\_\_

Manual Number: PM609  
Part Number: 75509  
Rev. 4



# TABLE OF CONTENTS

## 3509 & 3511 BACKHOE SERVICE PARTS

<b>MAINFRAME</b> .....	<b>#88093</b>
Mainframe	
Swing Post	
Swing Cylinder	
Stabilizers	
<b>3-POINT HITCH ADAPTER KIT</b> .....	<b>#88623</b>
<b>3509 BOOM &amp; DIPPER ASSEMBLY</b> .....	<b>#87716</b>
<b>3511 BOOM &amp; DIPPER ASSEMBLY</b> .....	<b>#87734</b>
<b>CONSOLE ASSEMBLY</b> .....	<b>#88607</b>
<b>VALVE ASSEMBLY</b> .....	<b>#2251</b>
<b>CYLINDERS</b>	
<b>SWING CYLINDER</b> .....	<b>#81827</b>
<b>STABILIZER CYLINDER</b> .....	<b>#86605</b>
<b>3509 BOOM CYLINDER</b> .....	<b>#86259</b>
<b>3511 BOOM CYLINDER</b> .....	<b>#87736</b>
<b>3509 DIPPER CYLINDER</b> .....	<b>#87717</b>
<b>3511 DIPPER CYLINDER</b> .....	<b>#87737</b>
<b>BUCKET CYLINDER</b> .....	<b>#87718</b>
<b>HOSE SETS</b>	
<b>MAINFRAME HOSE SET</b> .....	<b>#88531</b>
<b>3509 BOOM &amp; DIPPER HOSE SET</b> .....	<b>#88609</b>
<b>3511 BOOM &amp; DIPPER HOSE SET</b> .....	<b>#88528</b>
<b>STABILIZER PAD OPTIONS</b>	
<b>FLAT STABILIZER PAD ASSEMBLY</b> .....	<b>#81861</b>
<b>GROUSER STABILIZER PAD ASSEMBLY</b> .....	<b>#81860</b>
<b>RUBBER STABILIZER PAD ASSEMBLY</b> .....	<b>#81862</b>
<b>FLIP OVER STABILIZER PAD ASSEMBLY</b> .....	<b>#83058</b>
<b>STABILIZER CYLINDER GUARDS</b> .....	<b>#86706</b>
<b>BUCKET OPTIONS</b>	
<b>12" BUCKET</b> .....	<b>#85012</b>
<b>16" BUCKET</b> .....	<b>#85016</b>
<b>18" BUCKET</b> .....	<b>#85018</b>
<b>20" BUCKET</b> .....	<b>#85020</b>
<b>24" BUCKET</b> .....	<b>#85024</b>
<b>3509 FIRST LINE REPAIR KIT</b> .....	<b>#88673</b>
<b>3511 FIRST LINE REPAIR KIT</b> .....	<b>#88627</b>
<b>DECALS</b>	

# MAINFRAME ASSEMBLY

ASSEMBLY #88093

MAINFRAME

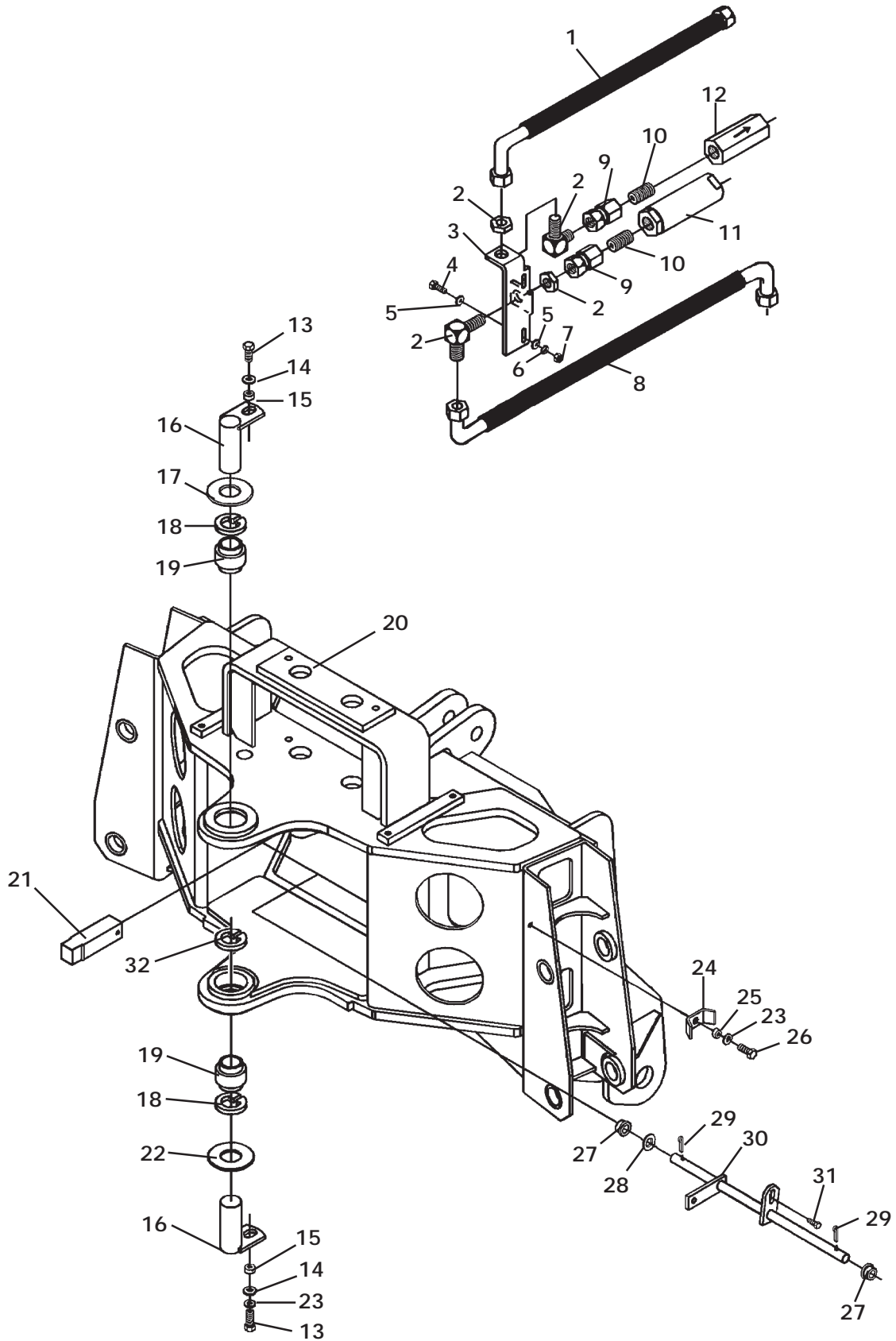

8042  
2-15-00

# MAINFRAME ASSEMBLY

ASSEMBLY #88093  
MAINFRAME

<u>NO</u>	<u>REQ'D</u>	<u>PART NO.</u>	<u>DESCRIPTION</u>
1	1	37746	Hose .50" X 18.50" 8FJX - 8FJX 90° Gooseneck
2	2	3382	90° Bulkhead Elbow (Includes Nut)
3	1	85540	Hose Mounting Bracket
4	2	1004	.25" UNC X 1.25" Hex Capscrew
5	4	1512	.25" Flat Washer
6	2	1501	.25" Lock Washer
7	2	1224	.25" UNC Hex Nut
8	1	37554	Hose .50" X 36"
			8FJX 90° Short Gooseneck - 8FJX 90° Short Gooseneck
9	2	3273	Coupling 8FP-8FJX
10	1	3211	Close Nipple .50" NPT (Inline Filter)
	1	3309	Heavy Close Nipple .50" NPT x 4.00" (Check Valve)
11	1	45132	Inline Filter (Round)
12	1	45691	Check Valve (Hex)
13	2	1043	.38" UNC X 1.00" Hex Capscrew
14	2	1514	.38" Flat Washer
15	2	81807	Spacer Tube
16	2	81592	Pin
	2	6616	Grease Zerk
17	1	83977	Thrust Washer 1.38" X .125"
18	2	1929	Snap Ring
19	2	6615	Bearing
20	1	88119	Mainframe (Includes (4) 83815 Bushings - Installed with Locktite Grade 680)
21	1	82090	Swing Lock Pin
22	As Req'd	83975	Thrust Washer 1.38" X .031"
	As Req'd	83976	Thrust Washer 1.38" X .093"
	As Req'd	83977	Thrust Washer 1.38" X .125"
23	3	1503	.38" Lock Washer
24	2	6186	Hose Clamp
25	2	6799	Spacer Tube
26	2	1044	.38" UNC X 1.25" Hex Capscrew
27	2	82794	Bushing
28	As Req'd	1528	.62" SAE Flat Washer
29	2	1611	Cotter Pin
30	1	82796	Linkage
31	1	1982	Shoulder Screw
32	1	1650	Snap Ring

8043  
5-3-05-2

# MAINFRAME ASSEMBLY

ASSEMBLY #88093  
SWING POST

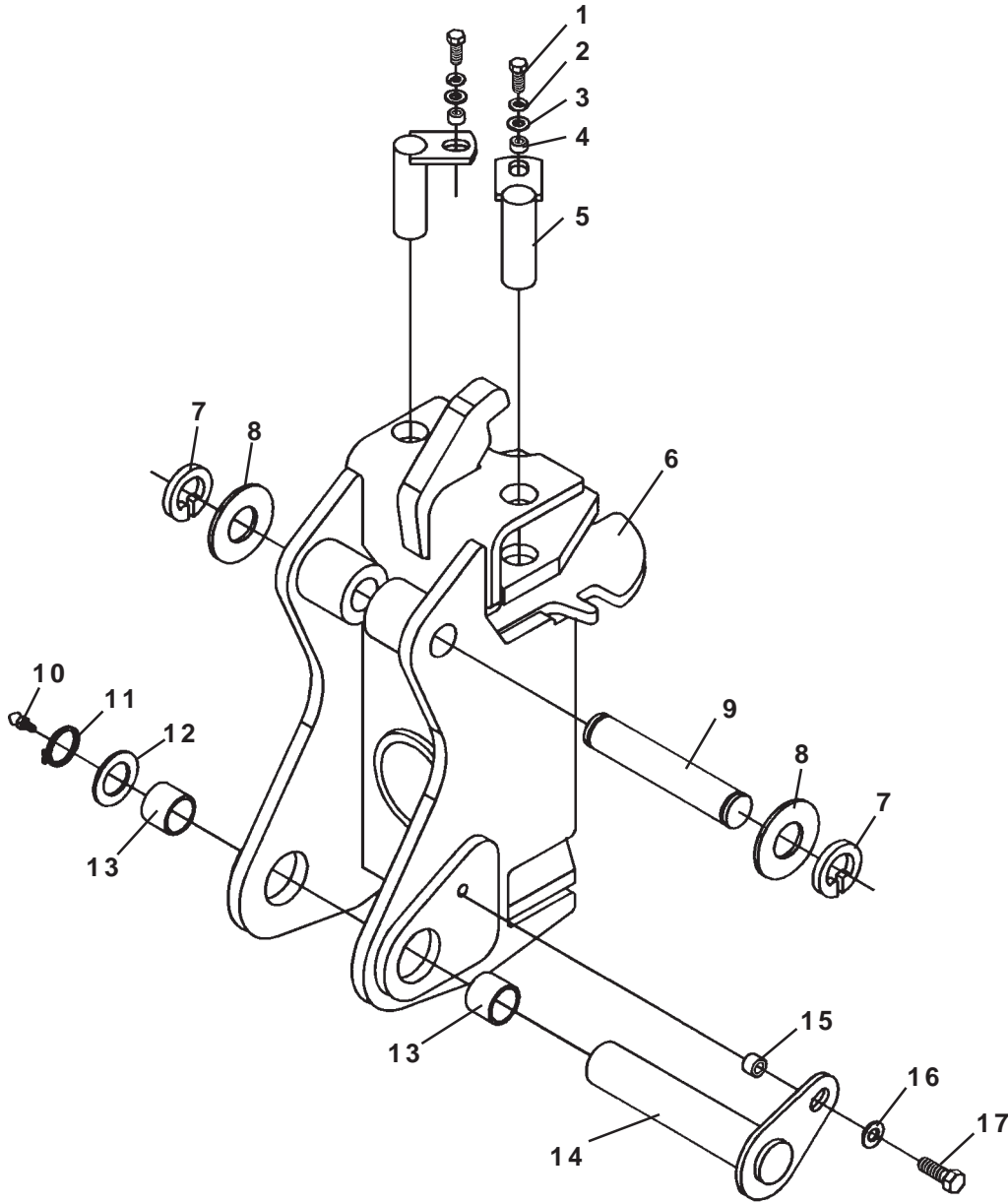

# MAINFRAME ASSEMBLY

ASSEMBLY #88093  
SWING POST

<u>NO</u>	<u>REQ'D</u>	<u>PART NO.</u>	<u>DESCRIPTION</u>
1	2	1043	.38" UNC X 1.00" Hex Capscrew
2	2	1503	.38" Lock Washer
3	2	1514	.38" Flat Washer
4	2	81807	Spacer Tube
5	2	81847	Pin
6	1	86201	Swing Post (Includes (2) 82402 Bushings - Installed with Locktite Grade 680)
7	2	1650	Snap Ring
8	As Req'd	83975	Thrust Washer 1.38" X
	As Req'd	83976	Thrust Washer 1.38" X
	As Req'd	83977	Thrust Washer 1.38" X
9	1	86220 (1)	Pivot Pin
10	1	6616	Grease Zerk
11	1	1651	Snap Ring
12	2	6622	Thrust Washer
13	-	82402	Bushing (Included in Swing Post Assembly) (Installed with Locktite Grade 680)
14	1	86227	Pivot Pin
15	1	86149	Spacer Tube
16	1	1516	.50" Flat Washer
17	1	1088	.50" UNC X 1.00" Capscrew (Installed with Locktite Grade 680)

**NOTE:**

- (1) Pivot Pin #86220 is sold only in Pin Kit #86317. Kit includes one pin #86220, two thrust washers #6623 and two snap rings #1650.

# MAINFRAME ASSEMBLY

ASSEMBLY #88093  
SWING CYLINDER

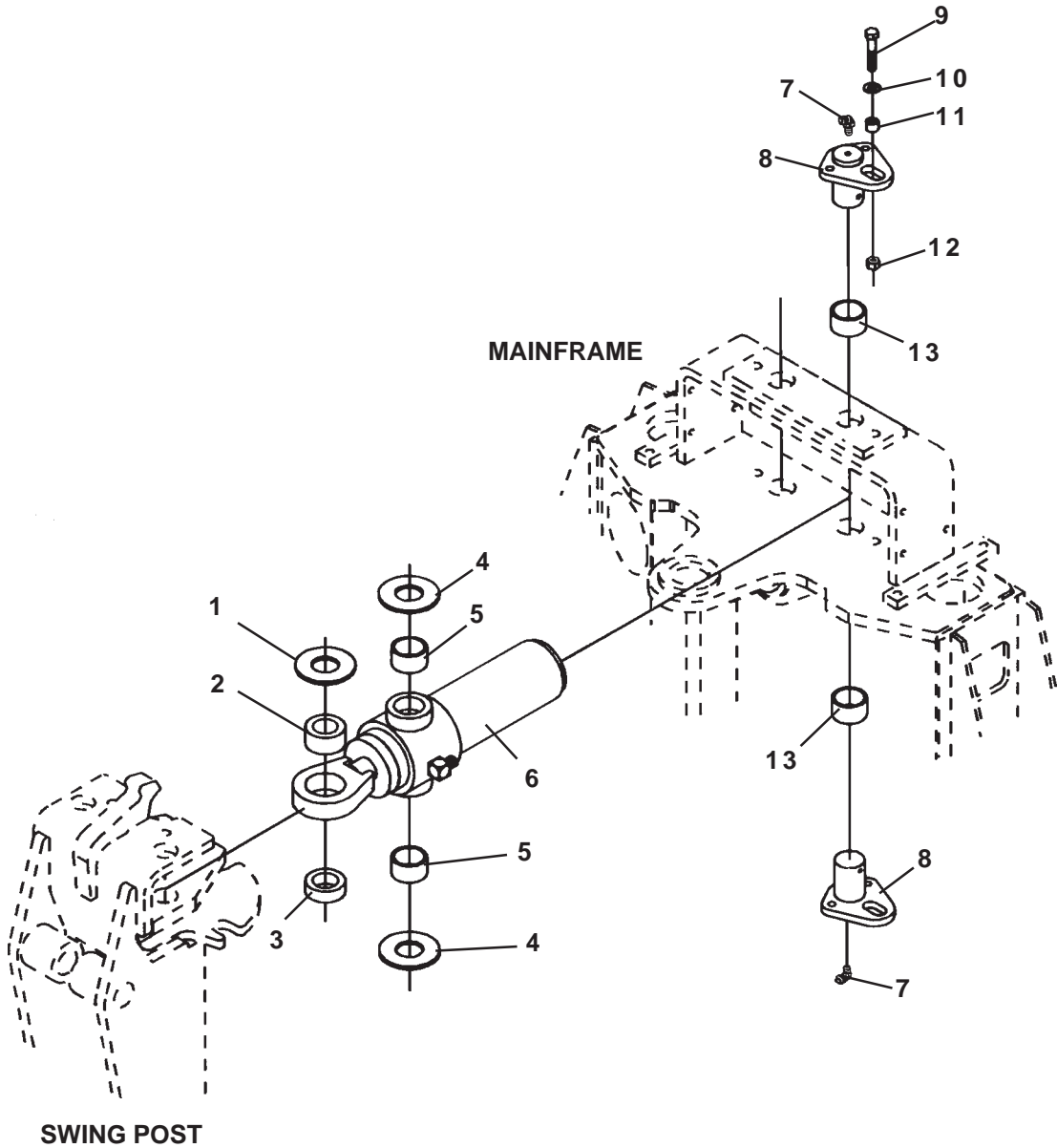



# MAINFRAME ASSEMBLY

ASSEMBLY #88093  
SWING CYLINDER

<u>NO</u>	<u>REQ'D</u>	<u>PART NO.</u>	<u>DESCRIPTION</u>
1	As Req'd	57693	Thrust Washer 1.25" X .078"
	As Req'd	64727	Thrust Washer 1.25" X .145"
	As Req'd	64728	Thrust Washer 1.25" X .031"
2	-	62523	Self-Aligning Bushing (Included in Swing Cylinder Assembly)
3	2	82827	Spacer
4	4	68057	Thrust Washer
5	-	82441	Needle Bearing (Included in Swing Cylinder Assembly)
6	2	81827	Swing Cylinder Assembly (Includes (2) 82441 Needle Bearings and (1) 62523 Bushings)
	2	6616	Grease Zerk
	2	30164	Tee - Special Lateral Tee
7	4	53031	90° Grease Zerk
8	4	82420	Pin
9	4	1047	.38" UNC X 2.00" Hex Capscrew
10	4	1514	.38" Flat Washer
11	4	81595	Spacer Tube
12	4	1837	.38" UNC Deformed Lock Nut
13	-	83815	Bushing (Included in Mainframe - Installed with Loctite Grade 680)

# MAINFRAME ASSEMBLY

ASSEMBLY #88093  
STABILIZERS

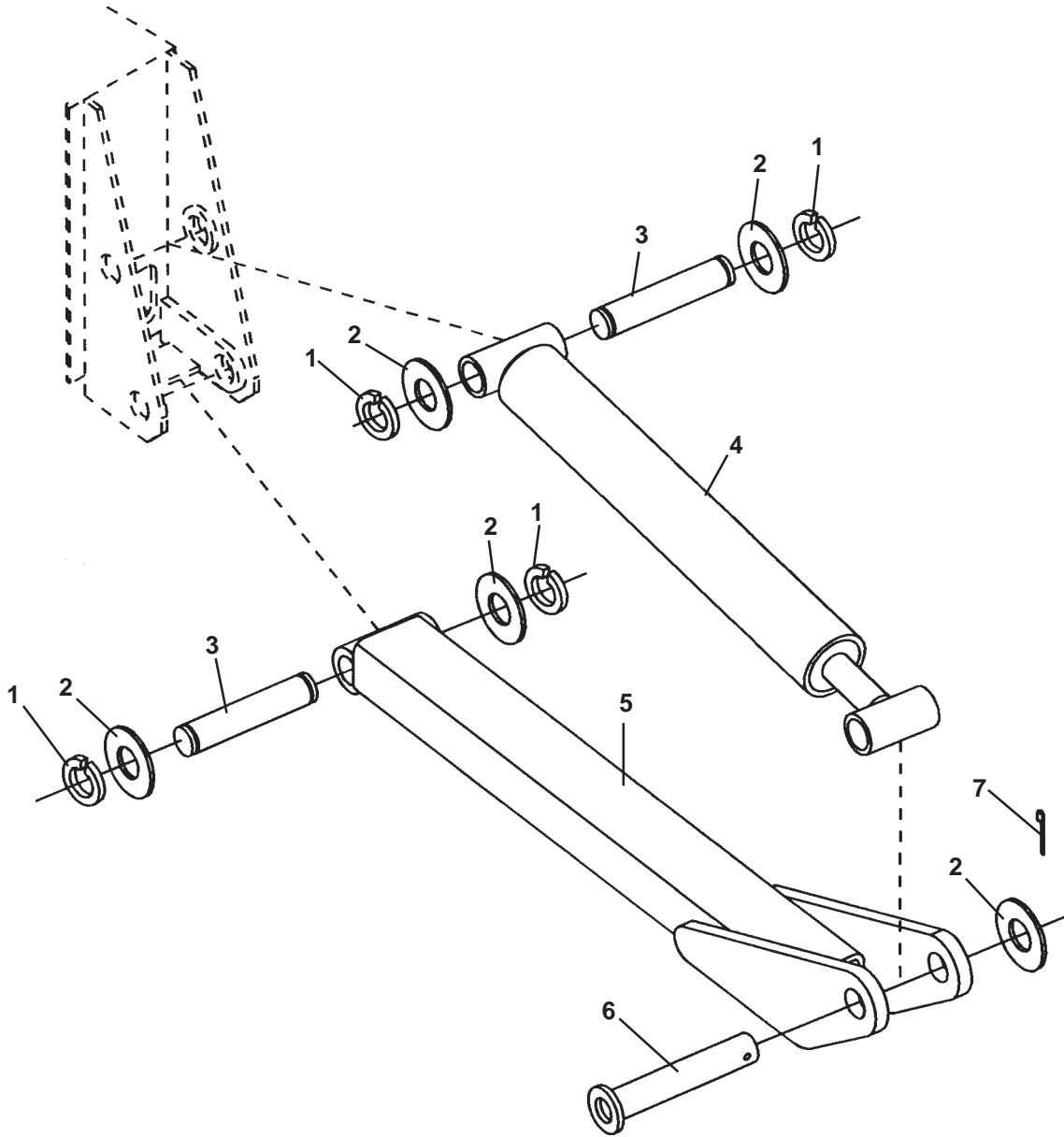

8048  
2-15-00

# MAINFRAME ASSEMBLY

ASSEMBLY #88093  
STABILIZERS

<u>NO</u>	<u>REQ'D</u>	<u>PART NO.</u>	<u>DESCRIPTION</u>
1	8	1652	Snap Ring
2	As Req'd	57693	Thrust Washer 1.25" X .078"
	As Req'd	64727	Thrust Washer 1.25" X .145"
	As Req'd	64728	Thrust Washer 1.25" X .031"
3	4	81846 (1)	Pin
4	2	86605 (2)	Stabilizer Cylinder Assembly (1.50" Rod)
	4	6616	Grease Zerk
5	2	83393	Stabilizer Arm
6	2	83257	Pin
7	2	1613	Cotter Pin

**NOTE:**

- (1) Pivot Pin #81846 is sold only in Pin Kit #86314. Kit includes one pin #81846, two thrust washers #64727 and two snap rings #1652.
- (2) Stabilizer Cylinder Assembly #86605 (1.50" Rod Dia.) replaces Stabilizer Cylinder Assembly #83397 (1.25" Rod Dia.). If ordering replacement parts see Assembly Diagram and Parts list for your existing cylinder. If replacing a complete Stabilizer Cylinder, order Assembly #86605.

# HOSE BUNDLE CLAMPS

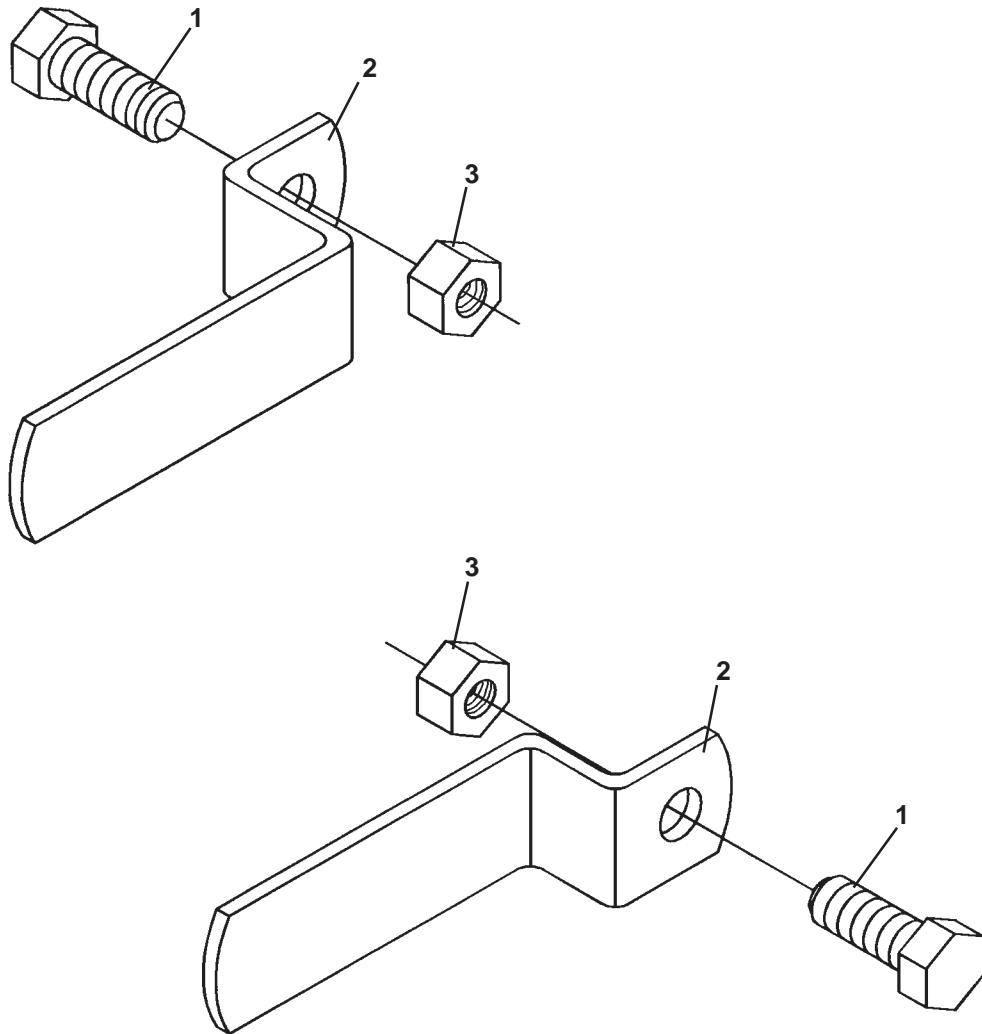

# HOSE BUNDLE CLAMPS

## UP TO SERIAL #---10065

<u>NO</u>	<u>REQ'D</u>	<u>PART NO.</u>	<u>DESCRIPTION</u>
1	2	1043	.38" UNC X 1.00" Hex Capscrew
2	1	84724	Right Hose Bundle Clamp
3	2	1837	.38" UNC Deformed Lock Nut
4	1	84718	Left Hose Bundle Clamp

## SERIAL #---10065 AND UP

<u>NO</u>	<u>REQ'D</u>	<u>PART NO.</u>	<u>DESCRIPTION</u>
1	2	1043	.38" UNC X 1.00" Hex Capscrew
2	1	84718	Right Hose Bundle Clamp
3	2	1837	.38" UNC Deformed Lock Nut
4	1	84718	Left Hose Bundle Clamp

# MOUNTING INSTRUCTIONS

3-POINT HITCH ADAPTER KIT #88623

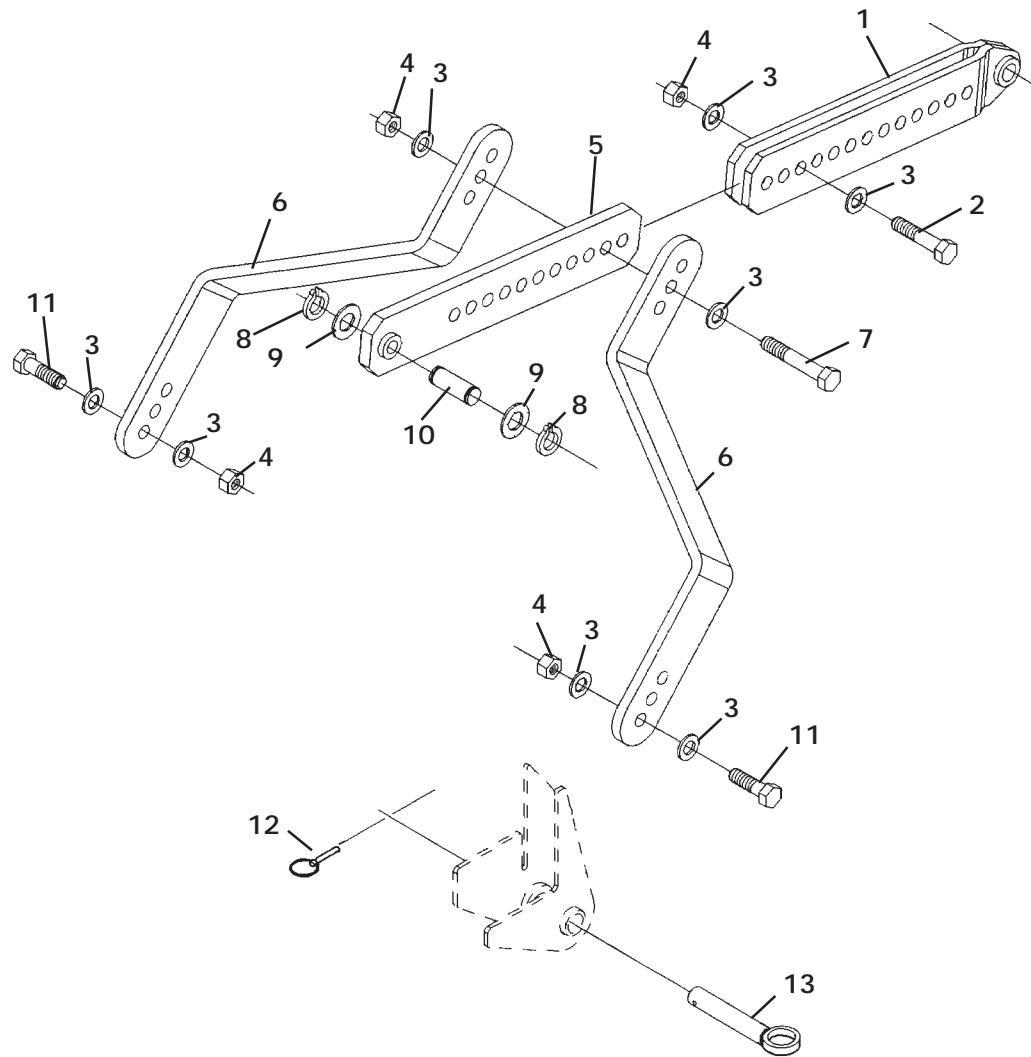

**MOUNTING INSTRUCTIONS**

3-POINT HITCH ADAPTER KIT #88623

<u>NO</u>	<u>REQ'D</u>	<u>PART NO.</u>	<u>DESCRIPTION</u>
1	1	87742	Center Double Link
2	1	1145	.75" UNC X 3.50" Hex Capscrew
3	8	1649	.75" Hard Flat Washer
4	4	1534	.75" UNC Hex Locknut
5	1	87743	Center Single Link
6	2	87741	Hitch Lock Out Arm
7	1	1149	.75" UNC X 5.00" Hex Capscrew
8	2	1570	Snap Ring
9	2	57462	Thrust Washer
10	1	87805	Pin
11	2	1142	.75" UNC X 2.75" Hex Capscrew
12	2	6626	Klik Pin
13	2	88117	Pin

**NOTE: USE HIGH STRENGTH PIN SUPPLIED BY YOUR TRACTOR MANUFACTURER TO ATTACH CENTER LINK TO TRACTOR.**





# 3509 BOOM & DIPPER ASSEMBLY

ASSEMBLY #87716

<u>NO</u>	<u>REQ'D</u>	<u>PART NO.</u>	<u>DESCRIPTION</u>
1	-	85772	Bushing (Included in Cylinder Assemblies)
2	1	87717	Dipper Cylinder Assembly
	2	6616	Grease Zerk
3	As Req'd	6623	Thrust Washer 1.38" x .031
	As Req'd	64724	Thrust Washer 1.38" x .090
	As Req'd	64725	Thrust Washer 1.38" x .125
4	1	86259	Boom Cylinder Assembly
	2	6616	Grease Zerk
5	1	34120	Hose Sock
6	1	53167	Hose Clamp (Included in Console Assembly)
7	3	1043	.38" UNC X 1.00" Hex Capscrew
8	1	1503	.38" Lock Washer
9	3	1514	.38" Flat Washer
10	1	86221	Hose Clamp Plate
11	1	86222	Rubber Spacer
12	-	86673	Bushing (Included in Boom Assembly) (Installed with Locktite Grade 680)
13	1	1972	Spring Pin
14	1	86366	Boom Lock
15	4	1650	Snap Ring
16	1	86242 (1)	Pivot Pin
17	1	1959	.88" UNC Jam Nut
18	2	6562	Spring Washer
19	1	84137	Guide Plate
20	2	1961	.38" UNC X .50" Hex FlangeHead Capscrew
21	1	86230	Handle
22	1	83656	Handle Grip
23	1	86151	Boom Assembly (Includes (4) 86673 Bushings) (Installed with Locktite Grade 680)
24	1	6616	Grease Zerk
25	1	86224 (2)	Pivot Pin
26	2	1837	.38" UNC Deformed Lock Nut
27	2	82859	Double Hose Clamp

## NOTE:

- (1) **Pivot Pin #86242 is sold only in Pin Kit #83615. Kit includes one pin #86242, two thrust washers #6623 and two snap rings #1650.**
- (2) **Pivot Pin #86224 is sold only in Pin Kit #83619. Kit includes one pin #86224, two thrust washers #6623, two snap rings #1650 and one grease zerk #6616.**

8072  
2-28-00

# 3509 BOOM & DIPPER ASSEMBLY

ASSEMBLY #87716

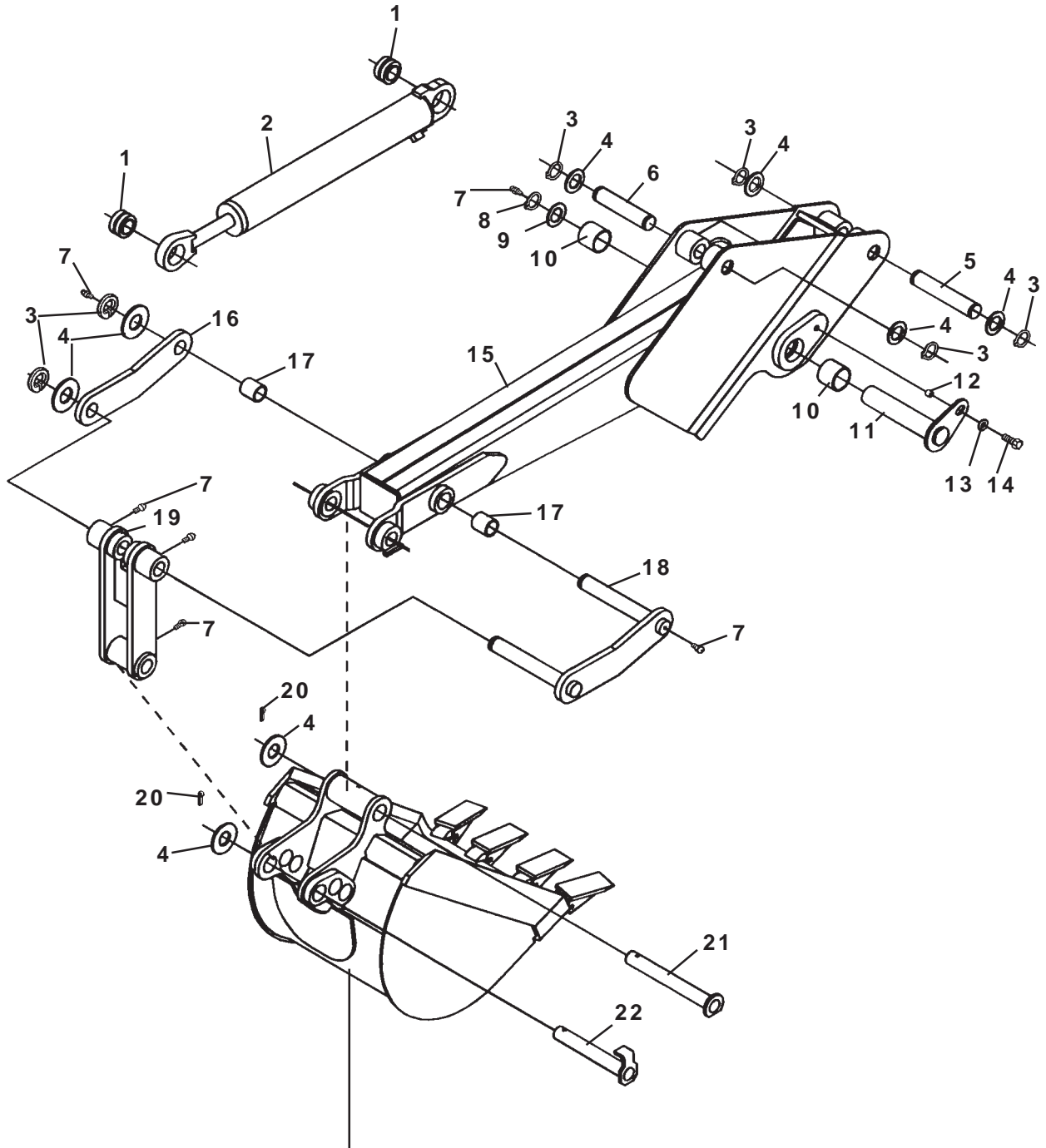

BUCKET  
(NOT INCLUDED IN BOOM AND DIPPER ASSEMBLY.)

# 3509 BOOM & DIPPER ASSEMBLY

ASSEMBLY #87716

<u>NO</u>	<u>REQ'D</u>	<u>PART NO.</u>	<u>DESCRIPTION</u>
1	-	85772	Bushing (Included in Cylinder Assembly)
2	1	87718	Bucket Cylinder Assembly
	2	6616	Grease Zerk
3	6	1650	Snap Ring
4	As Req'd	6623	Thrust Washer 1.38" X .031
	As Req'd	64724	Thrust Washer 1.38" X .090
	As Req'd	64725	Thrust Washer 1.38" X .125
5	1	86226 (1)	Pivot Pin
6	1	86225 (2)	Pivot Pin
7	6	6616	Grease Zerk
8	1	1651	Snap Ring
9	As Req'd	6622	Thrust Washer 1.75 X .082
10	-	82402	Bushing (Included in Dipper Assembly) (Install with Locktite Grade 680)
11	1	86227	Pivot Pin
12	1	86149	Spacer Tube
13	1	1516	.50" Flat Washer
14	1	1090	.50" UNC X 1.50" Hex Capscrew
15	1	86164	Dipper Assembly (Includes (2) 82402 and (2) 81610 Bushings) (Installed with Locktite Grade 680)
16	1	84914	Dipper Link Plate
17	-	81610	Bushing (Included in Dipper Assembly) (Install with Locktite Grade 680)
18	1	83428	Dipper Link
19	1	82523	Bucket Link
20	2	1613	Cotter Pin
21	1	82580	Pivot Pin
22	1	82595	Pivot Pin

**NOTE:**

- (1) **Pivot Pin #86226 is sold only in Pin Kit #86318. Kit Includes one pin #86226, two thrust washers #6623 and two snap rings #1650.**
- (2) **Pivot Pin #86225 is sold only in Pin Kit #86316. Kit Includes one pin #86226, two thrust washers #6623 and two snap rings #1650.**



# 3511 BOOM & DIPPER ASSEMBLY

ASSEMBLY #87734

<u>NO</u>	<u>REQ'D</u>	<u>PART NO.</u>	<u>DESCRIPTION</u>
1	-	85772	Bushing (Included in Cylinder Assemblies)
2	1	87737	Dipper Cylinder Assembly
	2	6616	Grease Zerk
3	As Req'd	6623	Thrust Washer 1.38" x .031
	As Req'd	64724	Thrust Washer 1.38" x .090
	As Req'd	64725	Thrust Washer 1.38" x .125
4	1	87736	Boom Cylinder Assembly
	2	6616	Grease Zerk
5	1	34120	Hose Sock
6	1	53167	Hose Clamp (Included in Console Assembly)
7	3	1043	.38" UNC X 1.00" Hex Capscrew
8	1	1503	.38" Lock Washer
9	3	1514	.38" Flat Washer
10	1	86221	Hose Clamp Plate
11	1	86222	Rubber Spacer
12	-	86673	Bushing (Included in Boom Assembly) (Installed with Locktite Grade 680)
13	1	1972	Spring Pin
14	1	86366	Boom Lock
15	4	1650	Snap Ring
16	1	86242 (1)	Pivot Pin
17	1	1959	.88" UNC Jam Nut
18	2	6562	Spring Washer
19	1	84137	Guide Plate
20	2	1961	.38" UNC X .50" Hex FlangeHead Capscrew
21	1	86230	Handle
22	1	83656	Handle Grip
23	1	86955	Boom Assembly (Includes (4) 86673 Bushings) (Installed with Locktite Grade 680)
24	1	6616	Grease Zerk
25	1	86224 (2)	Pivot Pin
26	2	1837	.38" UNC Deformed Lock Nut
27	2	82859	Double Hose Clamp

**NOTE:**

- (1) **Pivot Pin #86242 is sold only in Pin Kit #83615. Kit includes one pin #86242, two thrust washers #6623 and two snap rings #1650.**
- (2) **Pivot Pin #86224 is sold only in Pin Kit #83619. Kit includes one pin #86224, two thrust washers #6623, two snap rings #1650 and one grease zerk #6616.**

# 3511 BOOM & DIPPER ASSEMBLY

ASSEMBLY #87734

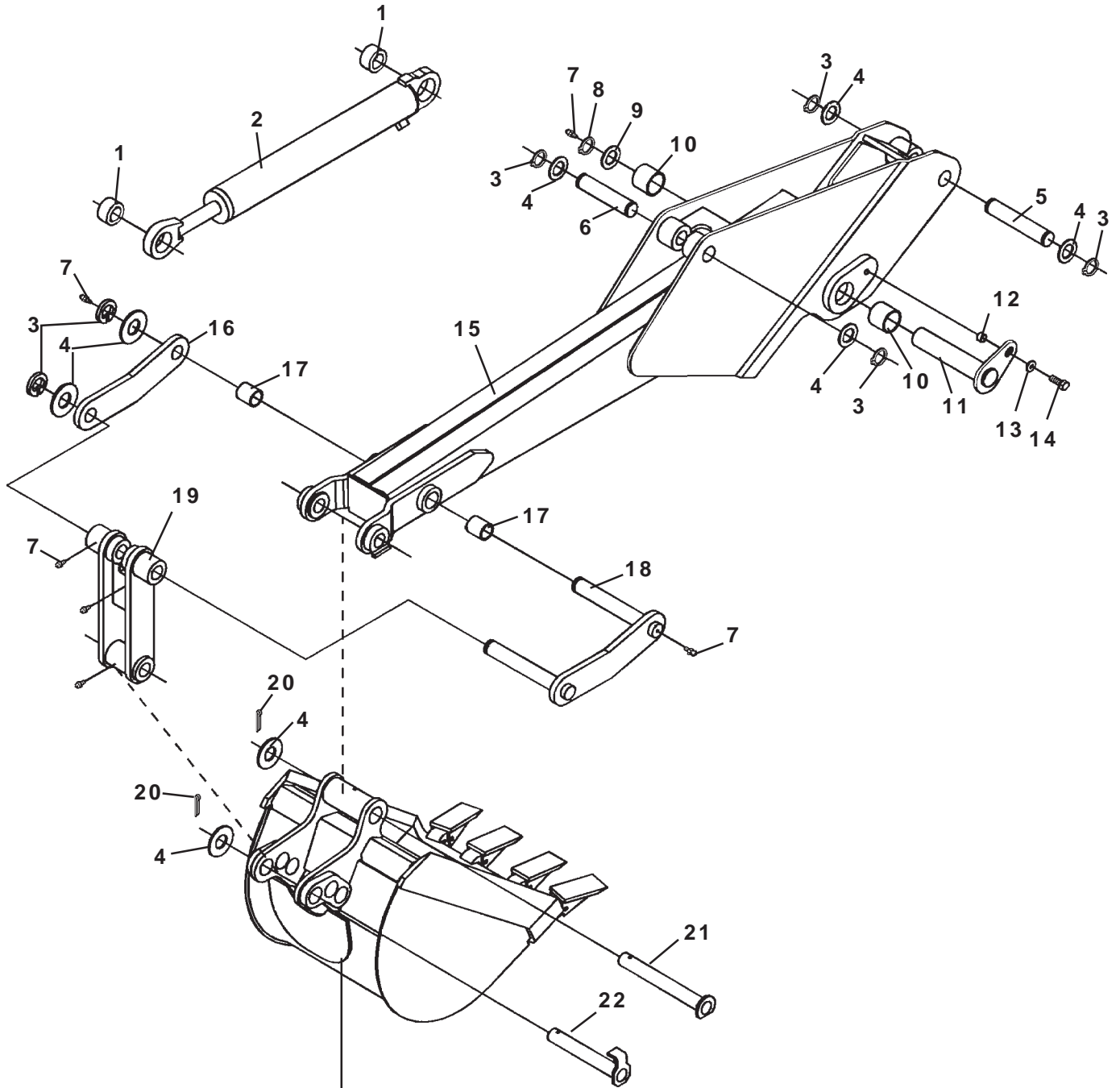

**BUCKET**  
**(NOT INCLUDED IN BOOM AND DIPPER ASSEMBLY.)**

# 3511 BOOM & DIPPER ASSEMBLY

ASSEMBLY #87734

<u>NO</u>	<u>REQ'D</u>	<u>PART NO.</u>	<u>DESCRIPTION</u>
1	-	85772	Bushing (Included in Cylinder Assembly)
2	1	87718	Bucket Cylinder Assembly
	2	6616	Grease Zerk
3	6	1650	Snap Ring
4	As Req'd	6623	Thrust Washer 1.38" X .031
	As Req'd	64724	Thrust Washer 1.38" X .090
	As Req'd	64725	Thrust Washer 1.38" X .125
5	1	86226 (1)	Pivot Pin
6	1	86225 (2)	Pivot Pin
7	6	6616	Grease Zerk
8	1	1651	Snap Ring
9	As Req'd	6622	Thrust Washer 1.75 X .082
10	-	82402	Bushing (Included in Dipper Assembly) (Install with Locktite Grade 680)
11	1	86227	Pivot Pin
12	1	86149	Spacer Tube
13	1	1516	.50" Flat Washer
14	1	1090	.50" UNC X 1.50" Hex Capscrew
15	1	86983	Dipper Assembly (Includes (2) 82402 and (2) 81610 Bushings) (Installed with Locktite Grade 680)
16	1	84914	Dipper Link Plate
17	-	81610	Bushing (Included in Dipper Assembly) (Install with Locktite Grade 680)
18	1	83428	Dipper Link
19	1	82523	Bucket Link
20	2	1613	Cotter Pin
21	1	82580	Pivot Pin
22	1	82595	Pivot Pin

**NOTE:**

- (1) **Pivot Pin #86226 is sold only in Pin Kit #86318. Kit Includes one pin #86226, two thrust washers #6623 and two snap rings #1650.**
- (2) **Pivot Pin #86225 is sold only in Pin Kit #86316. Kit Includes one pin #86226, two thrust washers #6623 and two snap rings #1650.**

# CONSOLE ASSEMBLY

ASSEMBLY #88607

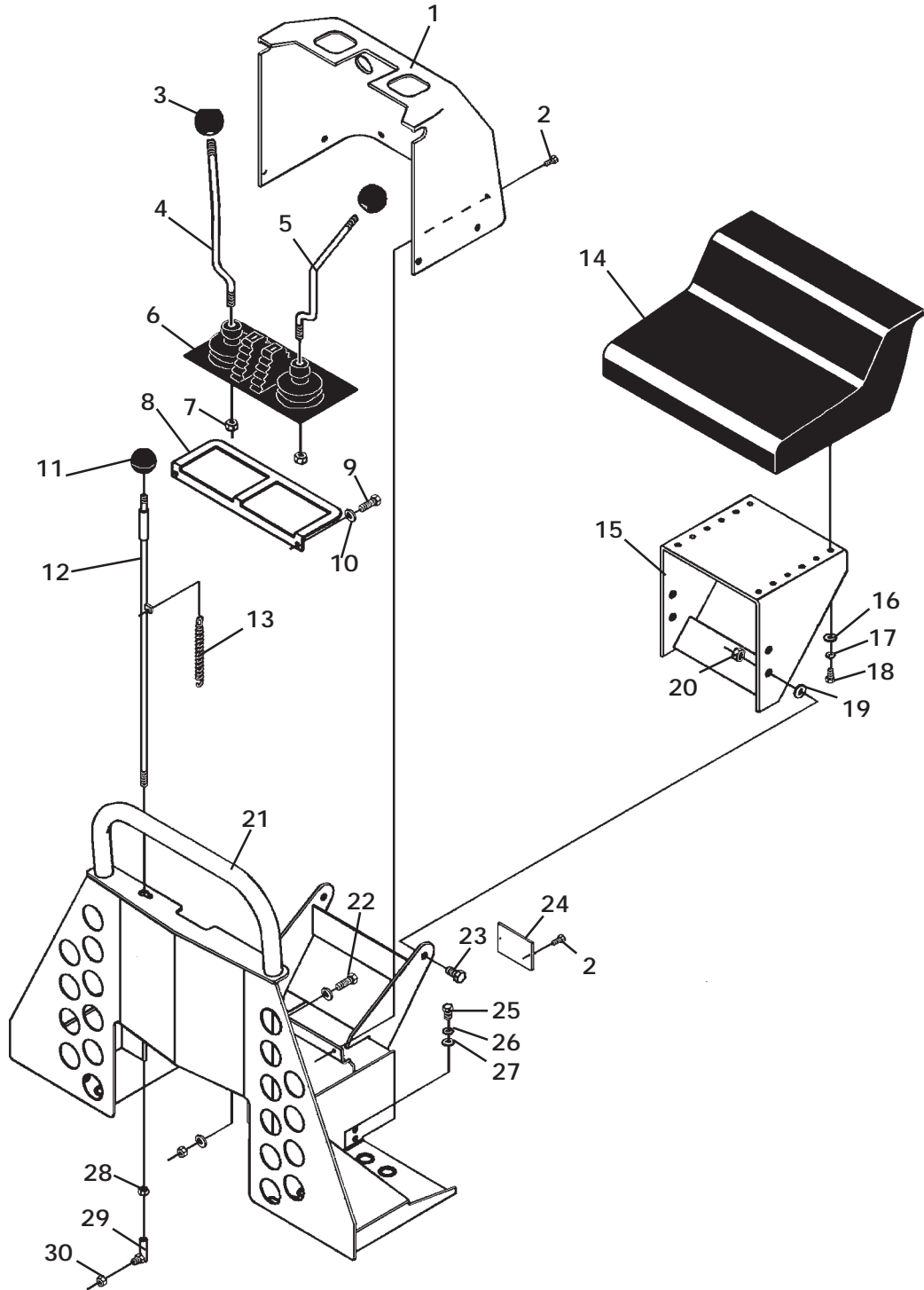



# CONSOLE ASSEMBLY

ASSEMBLY #88607

<u>NO</u>	<u>REQ'D</u>	<u>PART NO.</u>	<u>DESCRIPTION</u>
1	1	88622	Console Cover with Decals
2	8	1958	.25" UNC X .75" Hex Hex Body Bolt
3	2	85838	Ball Handle
4	1	87952	Control Handle - Right
5	1	87951	Control Handle - Left
6	1	83235	Control Lever Boot
7	2	2558	M10 Hex Nut
8	1	85826	Boot Support Plate
9	2	1001	.25" UNC X .50" Hex Capscrew
10	2	1501	.25" Lock Washer
11	1	83406	Ball Handle
12	1	83273	Rod
13	1	82795	Spring
14	1	6980	Seat
15	1	82999	Seat Mount
16	4	1513	.31" Flat Washer
17	4	1502	.31" Lock Washer
18	4	1021	.31" UNC X .75" Hex Capscrew
19	2	1516	.50" Flat Washer
20	2	1542	.50" UNC Lock Nut
21	1	87288	Console
22	2	1043	.38" UNC X 1.00" Hex Capscrew
	4	1514	.38" Flat Washer
	2	1837	.38" UNC Lock Nut
23	2	1089	.50" UNC X 1.25" Hex Capscrew
24	1	87147	Cover Plate
25	4	1042	.38" UNC X .75" Hex Capscrew
26	4	1503	.38" Lock Washer
27	4	1514	.38" Flat Washer
28	1	1476	.38" UNF Jam Nut
29	1	5545	Ball Joint
30	1	1592	.38" UNF Lock Nut

# VALVE ASSEMBLY

ASSEMBLY #2251

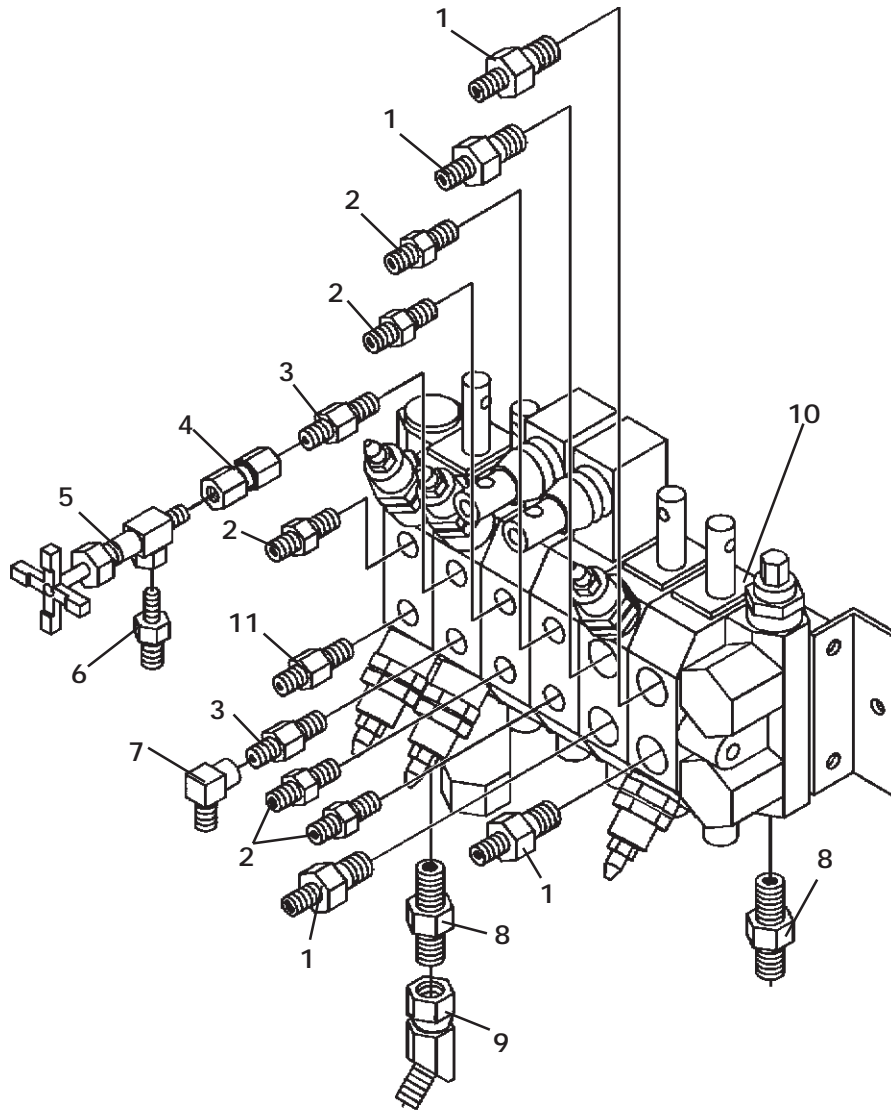

# VALVE ASSEMBLY

ASSEMBLY #2251

<u>NO</u>	<u>REQ'D</u>	<u>PART NO.</u>	<u>DESCRIPTION</u>
1	4	3269	Straight Adapter 8MBo-6MJ
2	5	3457	Straight Adapter 6MBo-6MJ
3	2	30185	Straight Adapter 6MBo-6MJ (With .076 Restrictor In - Free Flow Out)
4	1	30187	Swivel Connector 4FP-6FJX
5	1	3185	Needle Valve (Swing Speed Control)
6	1	3137	Straight Adapter 4MP-6MJ
7	1	3430	90° Street Adapter 6FJX-6MJ
8	2	3103	Straight Adapter 8MBo-8MJ
9	1	30015	45° Street Adapter 8FJX-8MJ
10	1	87075	6-Spool Hidroirma Valve with Float Position on Boom Section
11	1	30184	Straight Adapter 6MBo-6MJ (With .109 Restrictor In - Free Flow Out)

# VALVE ASSEMBLY

HIDROIRMA VALVE #87075

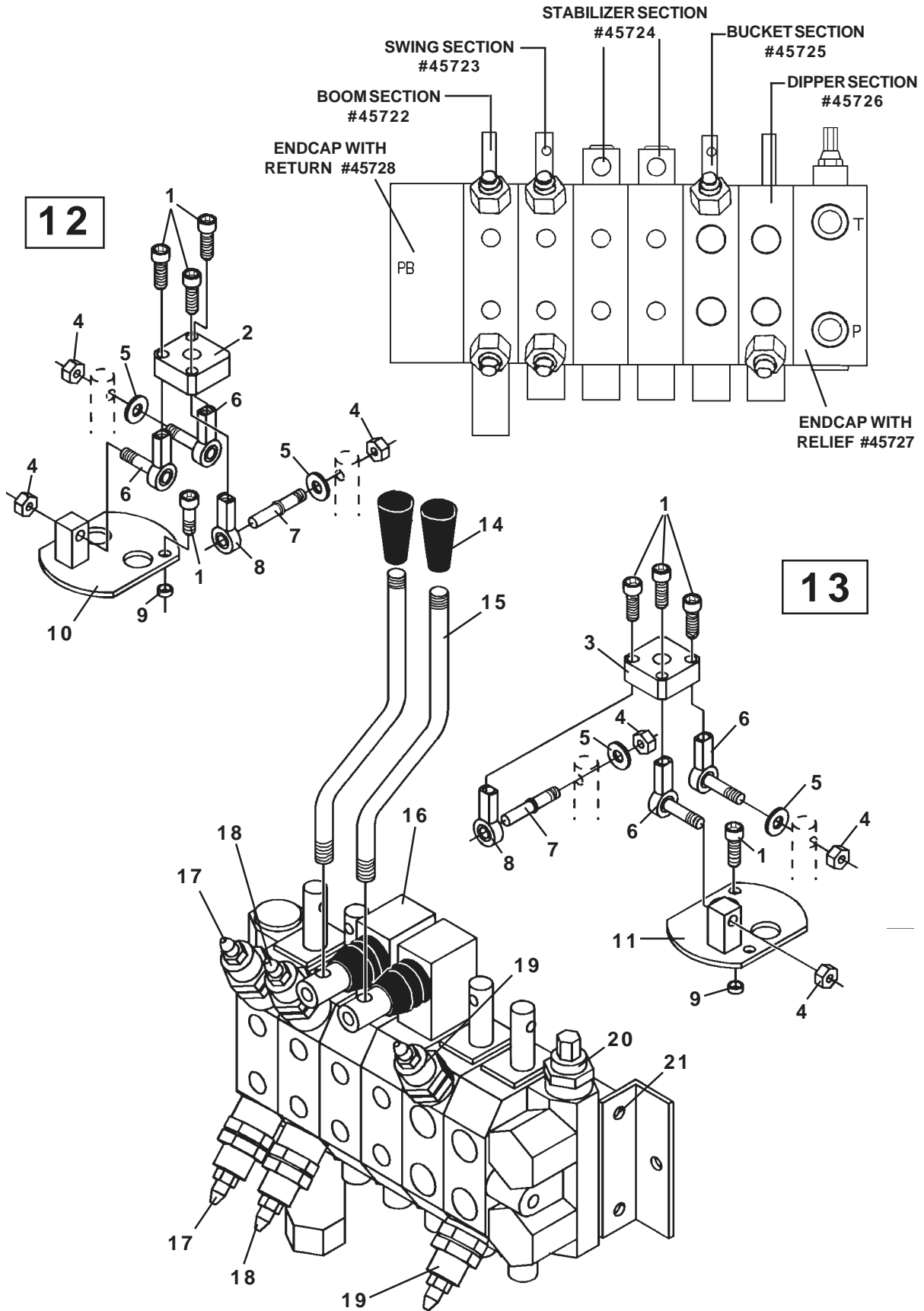

# VALVE ASSEMBLY

HIDROIRMA VALVE #87075

## SERVICE PARTS

<u>NO</u>	<u>REQ'D</u>	<u>PART NO.</u>	<u>DESCRIPTION</u>
1	10	45702	Screw
2	1	45704	Joystick Plate - Left
3	1	45705	Joystick Plate - Right
4	6	45706	Nut
5	4	45707	Washer
6	4	45708	Terminal With Stud
7	2	45709	Joystick Spool Pin
8	2	45710	Terminal
9	4	45711	Bushing
10	1	45712	Left Joystick Support
11	1	45713	Right Joystick Support
12	-	45717	Left Joystick Assembly (Includes Items 1, 2, 4, 5, 6, 7, 8, 9, 10)
13	-	45718	Right Joystick Assembly (Includes Items 1, 3, 4, 5, 6, 7, 8, 9, 11)
14	2	86338	Knob
15	2	85837	Stabilizer Control Lever
16	-	85511	Complete Valve Assembly (Includes all Items on this Page)
17	2	45714	Circuit Relief With Anti-Cav. @ 2500 PSI
18	2	45715	Circuit Relief With Anti-Cav. @ 2250 PSI
19	2	45716	Circuit Relief @ 2500 PSI
20	1	45719	Main Relief @ 2250 PSI
21	3	45736	Tie Bolt Assembly (Includes Tie Bolt, Washer & Nut)

# VALVE ASSEMBLY

## REPLACEMENT PARTS - HYDROIRMA VALVE

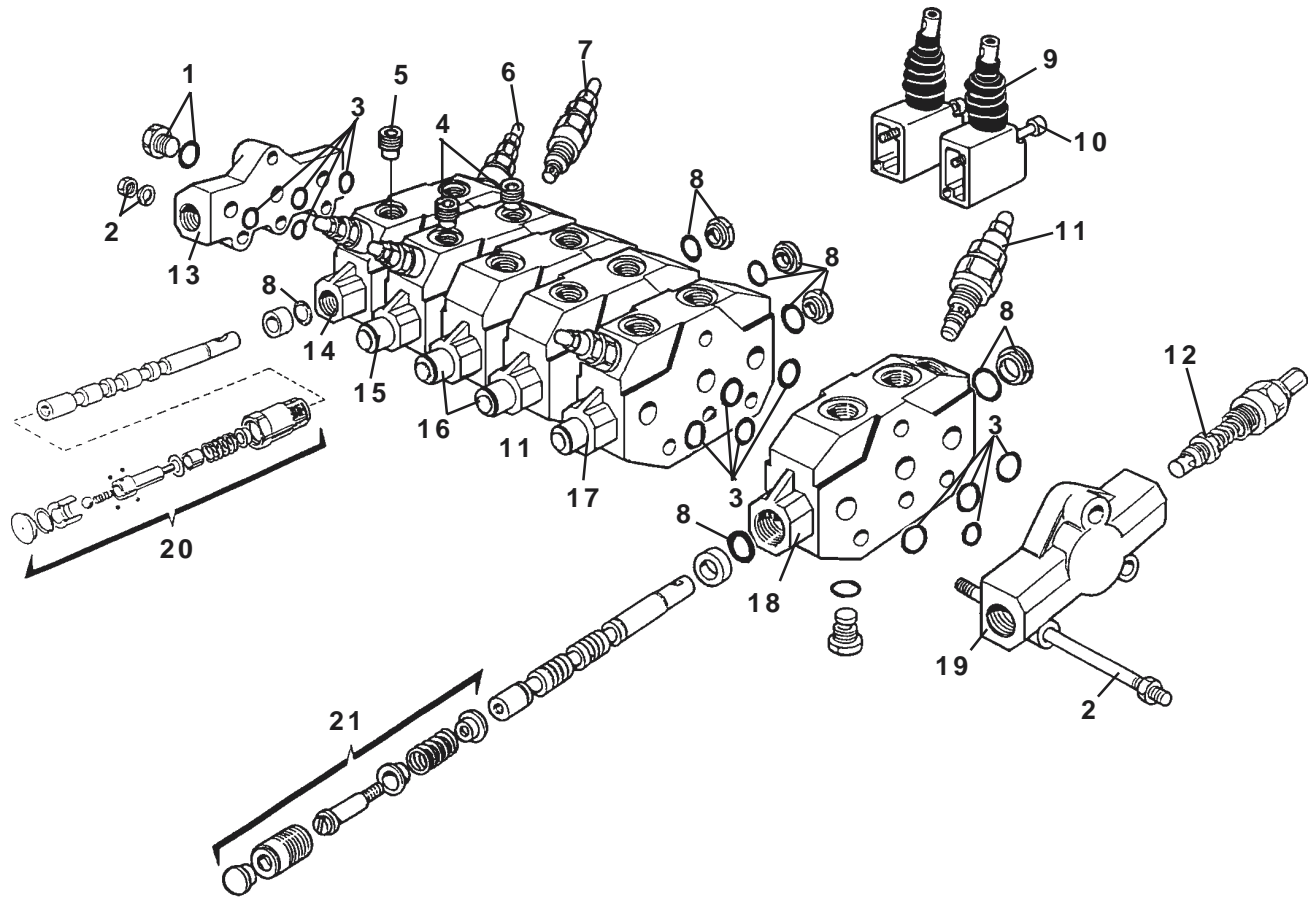

# VALVE ASSEMBLY

## REPLACEMENT PARTS - HIDROIRMA VALVE

<u>NO</u>	<u>REQ'D</u>	<u>PART NO.</u>	<u>DESCRIPTION</u>
1	-	3341	Plug 8MBo
	-	3306	Replacement O'Ring
2	-	45736	Tie Rod Assembly (Includes Nuts & Washers)
3	-	45720	Section Seal Kit
4	-	45731	Restrictor .076
5	-	45732	Restrictor .109
6	-	45714	Circuit Relief With Anti-Cav. @ 2500 PSI
7	-	45715	Circuit Relief With Anti-Cav. @ 2250 PSI
8	-	45721	Spool Seal Kit
9	-	45733	Stabilizer Lever Assembly
10	-	45735	Single Slot Screw
11	-	45716	Circuit Relief @ 2500 PSI
12	-	45719	Main Relief @ 2250 PSI
13	-	45728	Endcap With Return
14	-	45722	Valve Section - Boom
15	-	45723	Valve Section - Swing
16	-	45724	Valve Section - Stabilizers
17	-	45725	Valve Section - Bucket
18	-	45726	Valve Section - Dipper
19	-	45727	Endcap With Relief
20	-	45730	Float Assembly (Spool NOT Included) (If Float Spool is damaged, it is recommended to purchase a complete Valve Section.)
21	-	45729	Positioner Assembly (Spool NOT Included) (If Positioner Spool is damaged, it is recommended to purchase a complete Valve Section.)

### NOTES:

Items without part numbers are not sold separately.

Spool Seal Kit #45721 contains (2) O-Ring Seals and (1) Flanged Washer.

Section Seal Kit #45720 includes (4) O'Rings O'Ring Seals.

# CYLINDER ASSEMBLY

SWING CYLINDER ASSEMBLY #81827

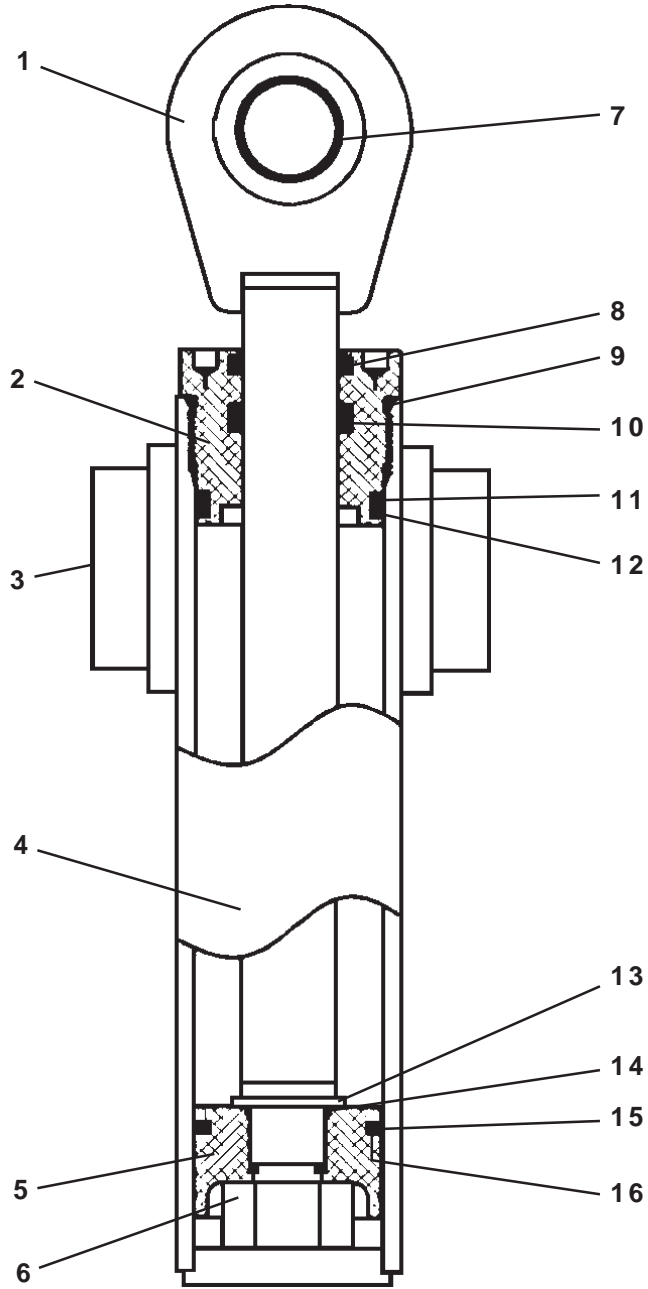



# CYLINDER ASSEMBLY

SWING CYLINDER ASSEMBLY #81827

<u>NO</u>	<u>REQ'D</u>	<u>PART NO.</u>	<u>DESCRIPTION</u>
1	1	81024	Cylinder Rod
2	1	77458	Cylinder Gland
3	2	82441	Needle Bearing
4	1	81960	Cylinder Tube
5	1	81963	Piston
6	1	1483	Hex Nut
7	1	62523	Self Aligning Bushing
8	1	45389*	Rod Wiper
9	1	45250*	O'Ring
10	1	45219*	Poly Pak Seal
11	1	4510*	Back-Up Ring
12	1	4509*	O'Ring
13	1	5421	Washer
14	1	4641*	O'Ring
15	1	4644*	Piston Ring
16	1	4645*	O'Ring

NOTE: Seal Kit #45617 Includes all parts marked with an asterisk (\*).  
Parts are not sold separately.

# CYLINDER ASSEMBLY

STABILIZER CYLINDER ASSEMBLY #86605  
(1.50" DIAMETER CYLINDER ROD)

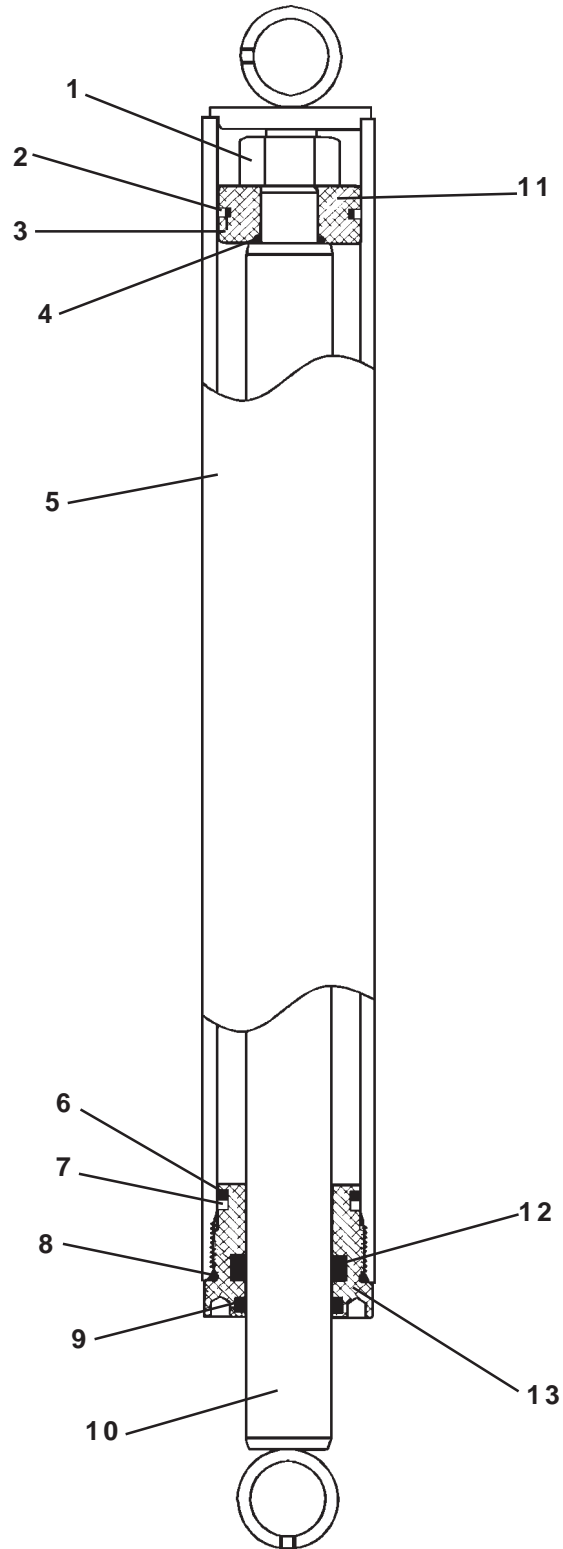

# **CYLINDER ASSEMBLY**

STABILIZER CYLINDER ASSEMBLY #86605  
(1.50" DIAMETER CYLINDER ROD)

<b><u>NO</u></b>	<b><u>REQ'D</u></b>	<b><u>PART NO.</u></b>	<b><u>DESCRIPTION</u></b>
1	1	1483	Hex Nut
2	1	4644*	Teflon Piston Ring
3	1	4645*	O'Ring
4	1	4641*	O'Ring
5	1	83398	Cylinder Tube
6	1	4509*	O'Ring
7	1	4510*	Back-Up Ring
8	1	45250*	O'Ring
9	1	45372*	Rod Wiper
10	1	86606	Cylinder Rod
11	1	50252	Piston
12	1	45225*	Poly-Pak Seal
13	1	86609	Cylinder Gland

NOTE: Seal Kit #45738 includes all parts marked with an asterisk (\*).  
Parts are not sold separately.

# CYLINDER ASSEMBLY

BOOM CYLINDER ASSEMBLY #86259

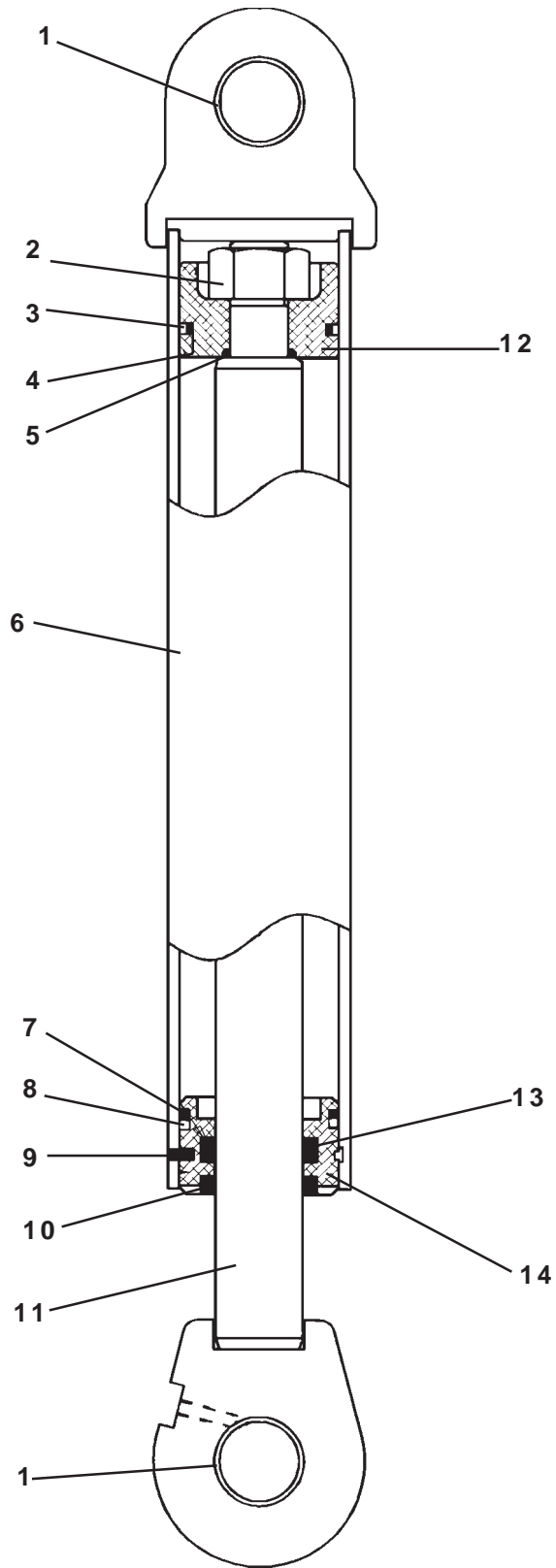

# CYLINDER ASSEMBLY

BOOM CYLINDER ASSEMBLY #86259

<u>NO</u>	<u>REQ'D</u>	<u>PART NO.</u>	<u>DESCRIPTION</u>
1	2	85772	Bushing
2	1	1483	Hex Nut
3	1	45251*	Piston Ring
4	1	45250*	O'Ring
5	1	4641*	O'Ring
6	1	86260	Cylinder Tube
7	1	45248*	O'Ring
8	1	45249*	Back-Up Ring
9	1	65465*	Gland Retaining Rod
10	1	4914*	Rod Wiper
11	1	86261	Cylinder Rod
12	1	82857	Piston
13	1	45225*	Poly-Pak Seal
14	1	85645	Cylinder Gland

NOTE: Seal Kit #45753 includes all parts marked with an asterisk (\*).  
Parts are not sold separately.

# CYLINDER ASSEMBLY

BOOM CYLINDER ASSEMBLY #87736

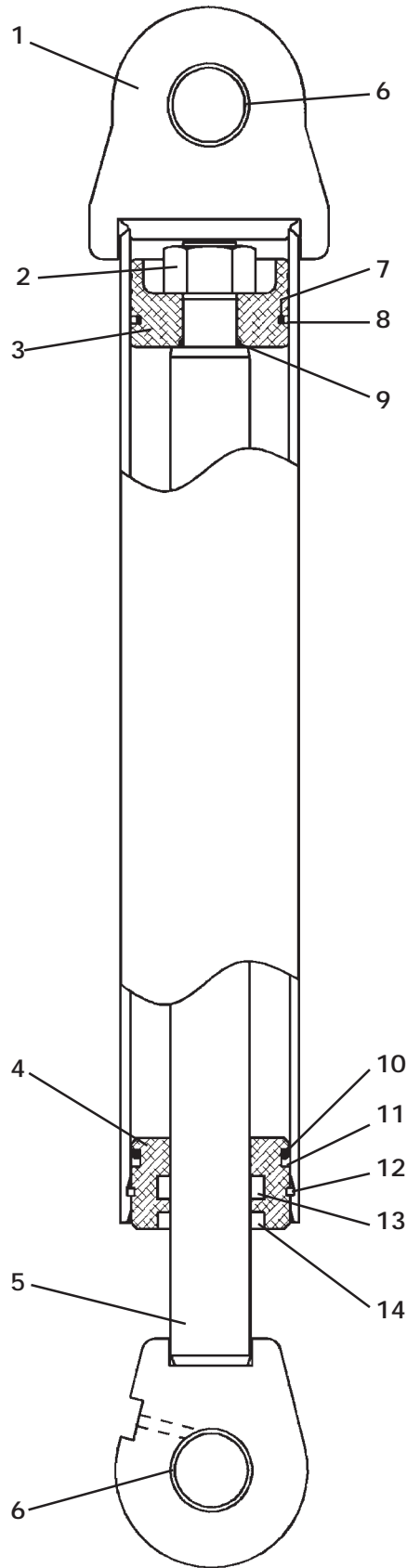

# CYLINDER ASSEMBLY

BOOM CYLINDER ASSEMBLY #87736

<u>NO</u>	<u>REQ'D</u>	<u>PART NO.</u>	<u>DESCRIPTION</u>
1	1	87766	Cylinder Tube
2	1	1483	Hex Nut
3	1	82793	Piston
4	1	63108	Cylinder Gland
5	1	87769	Cylinder Rod
6	2	85772	Bushing
7	1	4570*	O-Ring
8	1	4569*	Teflon Piston Ring
9	1	4641*	O-Ring
10	1	45555*	O-Ring
11	1	4631*	Back-Up Washer
12	1	7166*	Gland Retainer Rod
13	1	45225*	Poly-Pak Seal
14	1	4914*	Rod Wiper

NOTE: Seal Kit #45539 includes all parts marked with an asterisk (\*).  
Parts are not sold separately.

# CYLINDER ASSEMBLY

DIPPER CYLINDER ASSEMBLY #87717

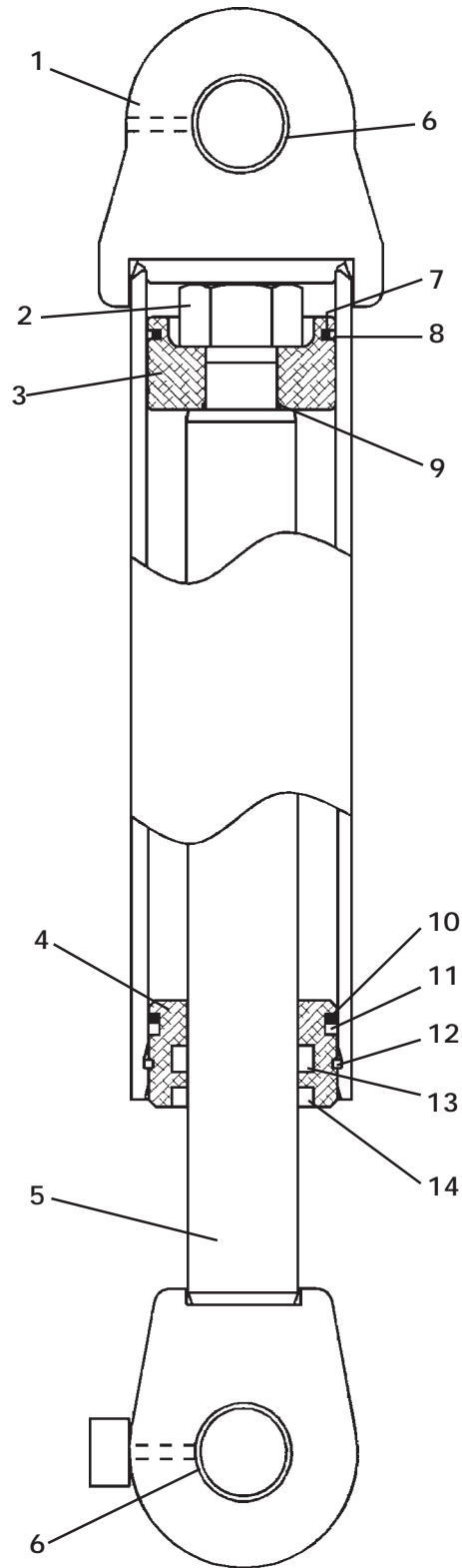



# CYLINDER ASSEMBLY

DIPPER CYLINDER ASSEMBLY #87717

<u>NO</u>	<u>REQ'D</u>	<u>PART NO.</u>	<u>DESCRIPTION</u>
1	1	87732	Cylinder Tube
2	1	1484	Hex Nut
3	1	86241	Piston
4	1	55914	Cylinder Gland
5	1	86274	Cylinder Rod
6	2	85772	Bushing
7	1	4570*	O-Ring
8	1	4569*	Teflon Piston Ring
9	1	4865*	O-Ring
10	1	45555*	O-Ring
11	1	4631*	Back-Up Washer
12	1	7166*	Gland Retainer Rod
13	1	45119*	Poly-Pak Seal
14	1	45118*	Rod Wiper

NOTE: Seal Kit #45541 includes all parts marked with an asterisk (\*).  
Parts are not sold separately.

# CYLINDER ASSEMBLY

DIPPER CYLINDER ASSEMBLY #87737

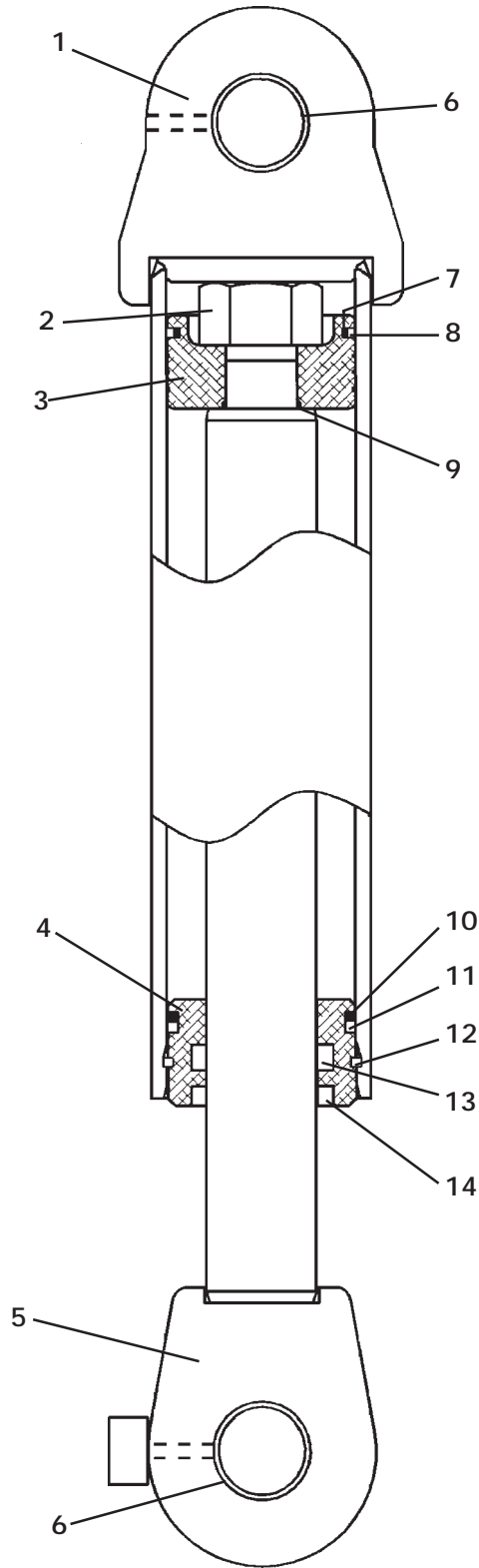

# CYLINDER ASSEMBLY

DIPPER CYLINDER ASSEMBLY #87737

<u>NO</u>	<u>REQ'D</u>	<u>PART NO.</u>	<u>DESCRIPTION</u>
1	1	87762	Cylinder Tube
2	1	1484	Hex Nut
3	1	86241	Piston
4	1	55914	Cylinder Gland
5	1	87764	Cylinder Rod
6	2	85772	Bushing
7	1	4570*	O-Ring
8	1	4569*	Teflon Piston Ring
9	1	4865*	O-Ring
10	1	45555*	O-Ring
11	1	4631*	Back-Up Washer
12	1	7166*	Gland Retainer Rod
13	1	45119*	Poly-Pak Seal
14	1	45118*	Rod Wiper

NOTE: Seal Kit #45541 includes all parts marked with an asterisk (\*).  
Parts are not sold separately.

# CYLINDER ASSEMBLY

BUCKET CYLINDER ASSEMBLY #87718

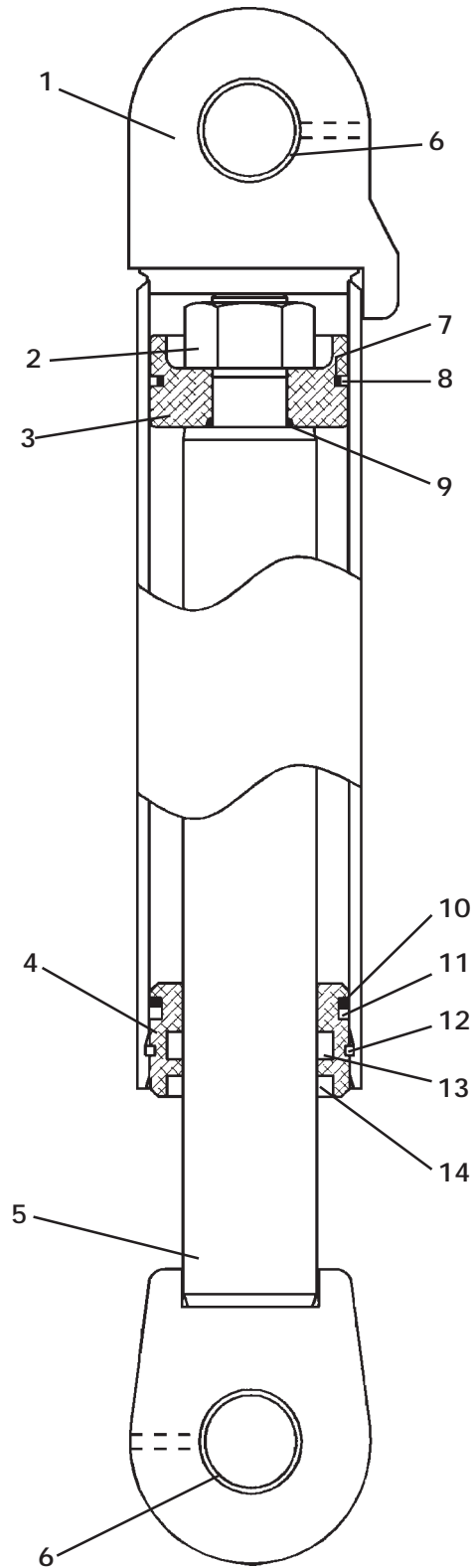

# CYLINDER ASSEMBLY

BUCKET CYLINDER ASSEMBLY #87718

<u>NO</u>	<u>REQ'D</u>	<u>PART NO.</u>	<u>DESCRIPTION</u>
1	1	87719	Cylinder Tube
2	1	1484	Hex Nut
3	1	55904	Piston
4	1	55911	Cylinder Gland
5	1	86287	Cylinder Rod
6	2	85772	Bushing
7	1	4570*	O-Ring
8	1	4569*	Teflon Piston Ring
9	1	4865*	O-Ring
10	1	45555*	O-Ring
11	1	4631*	Back-Up Washer
12	1	7166*	Gland Retainer Rod
13	1	45117*	Poly-Pak Seal
14	1	45105*	Rod Wiper

NOTE: Seal Kit #45542 includes all parts marked with an asterisk (\*).  
Parts are not sold separately.

# MAINFRAME HOSE SET

ASSEMBLY #88531

HYDRAULIC CONTROL VALVE

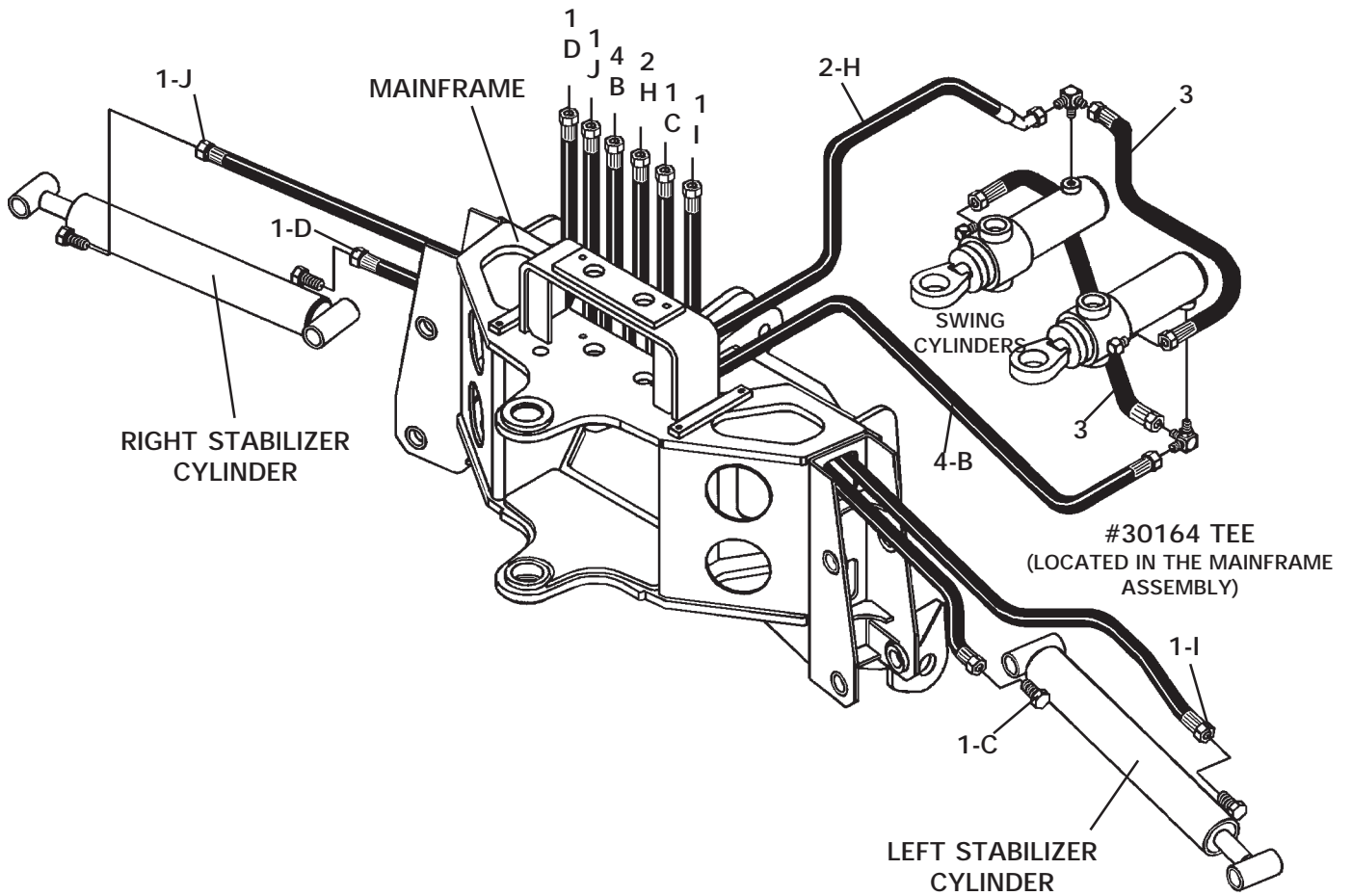
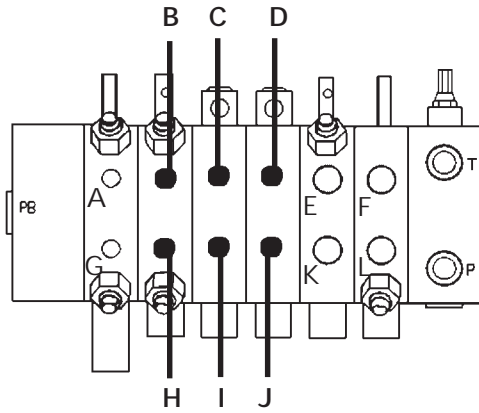

# MAINFRAME HOSE SET

ASSEMBLY #88531

<u>NO</u>	<u>REQ'D</u>	<u>PART NO.</u>	<u>DESCRIPTION</u>
1	4	35829	Hose Assembly .25" X 60" 6FJX - 6FJX
2	1	37700	Hose Assembly .25" X 12" 6FJX - 6FJX 45° Gooseneck
3	2	37552	Hose Assembly .25" X 14.50" 6FJX - 6FJX
4	1	37699	Hose Assembly .25" X 17" 6FJX - 6FJX

NOTE: Refer to the mainframe assembly for the priority valve hoses which are included in this assembly but have been shown in the mainframe assembly for clarity.

NOTE: Letters on the hose set diagram show the hydraulic hose routing between the backhoe control valve and the various hydraulic cylinders. Simply match the letter on the control valve port to the same letter on the hydraulic hose ends. Example: Hose Assembly labeled "C" runs from the upper Left Stabilizer port on the hydraulic control valve - through the mainframe and to the barrel end fitting on the left stabilizer cylinder.

NOTE: The fittings on the hydraulic cylinders have been altered for clarity purposes. this will assist you in distinguishing between the rod end and the barrel end of the various hydraulic cylinders.

8053  
2-16-00

# 3509 BOOM & DIPPER HOSE SET

ASSEMBLY #88609

HYDRAULIC CONTROL VALVE

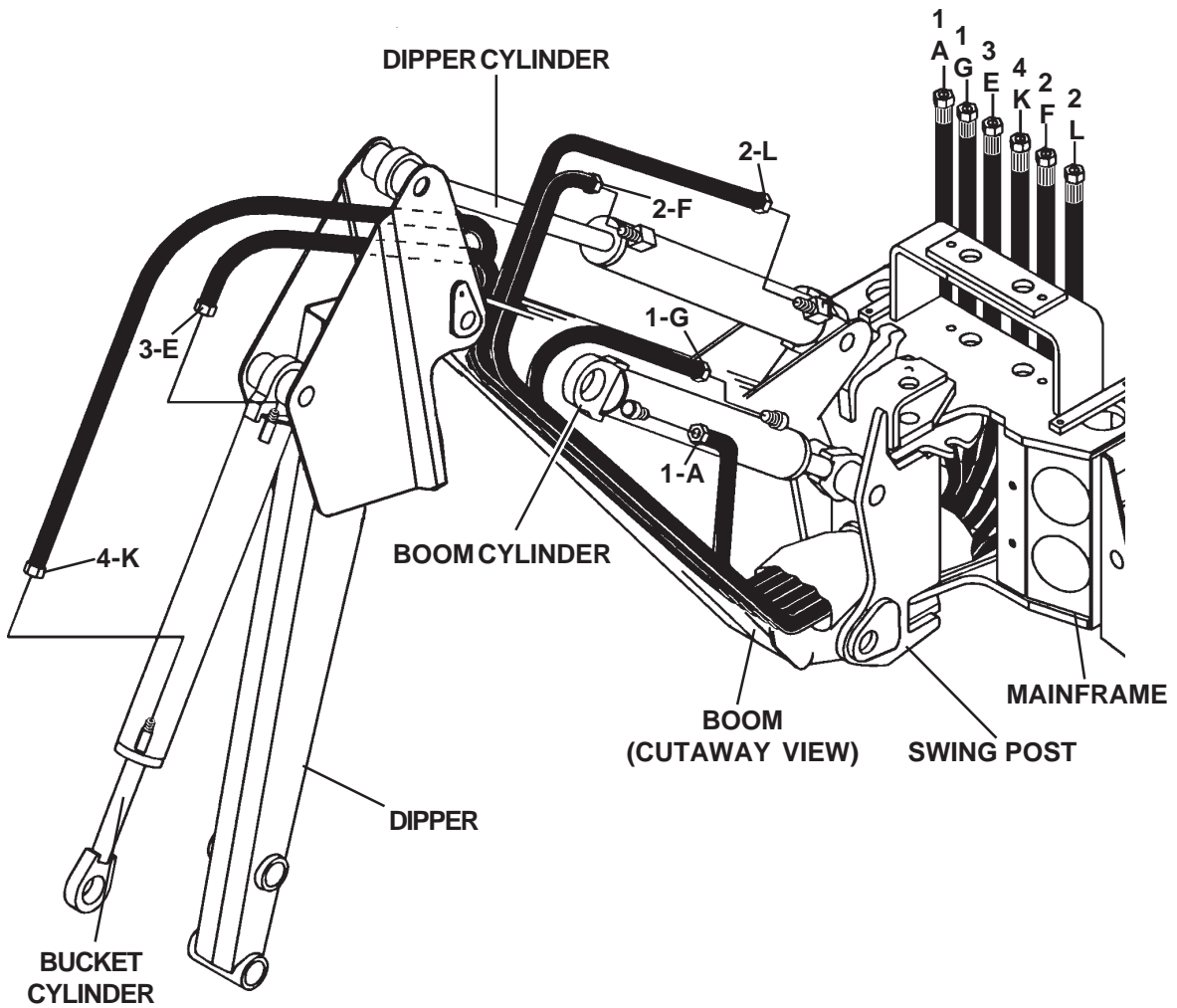
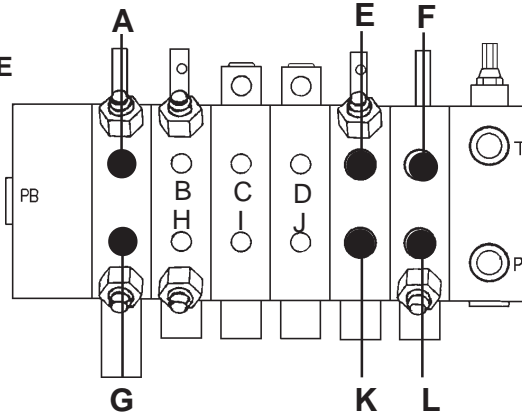

8075  
2-28-00



# 3509 BOOM & DIPPER HOSE SET

ASSEMBLY #88609

<u>NO</u>	<u>REQ'D</u>	<u>PART NO.</u>	<u>DESCRIPTION</u>
1	2	37677	Hose Assembly .38" X 95" 6FJX-6FJX
2	2	37678	Hose Assembly .38" X 137" 6FJX-6FJX
3	1	37679	Hose Assembly .38" X 139.50" 6FJX-6FJX
4	1	37748	Hose Assembly .38" X 160" 6FJX-6FJX

NOTE: Letters on the hose set diagram show the hydraulic hose routing between the backhoe control valve and the various hydraulic cylinders. Simply match the letter on the control valve port to the same letter on the hydraulic hose ends. Example: Hose Assembly labeled "G" runs from the lower Boom port on the hydraulic control valve - through the mainframe and swing post and to the rod end of the boom cylinder.

NOTE: The fittings on the hydraulic cylinders have been altered for clarity purposes. This will assist you in distinguishing between the rod end and the barrel end of the various hydraulic cylinders.

8076  
2-28-00

# 3511 BOOM & DIPPER HOSE SET

ASSEMBLY #88528

HYDRAULIC CONTROL VALVE

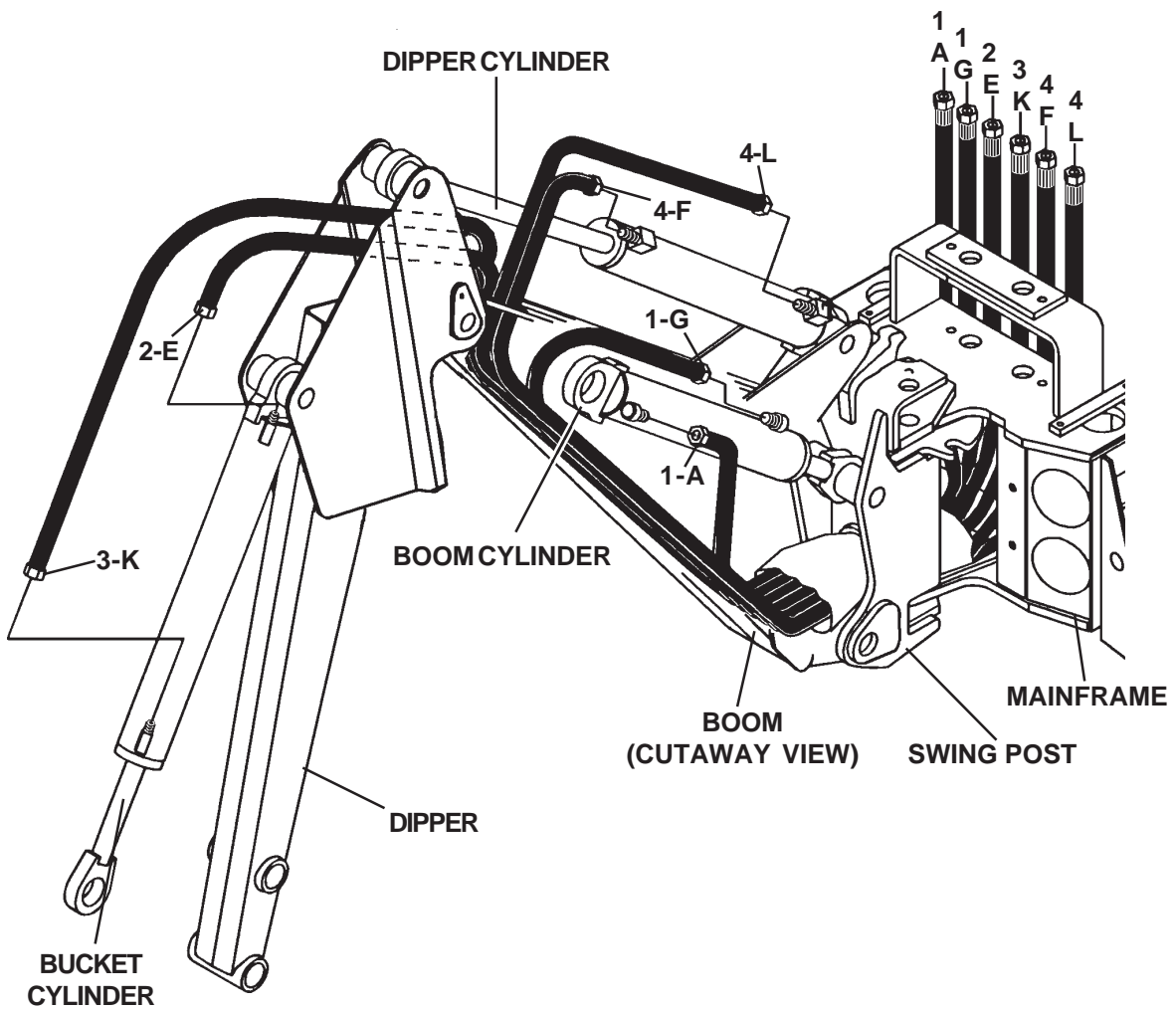
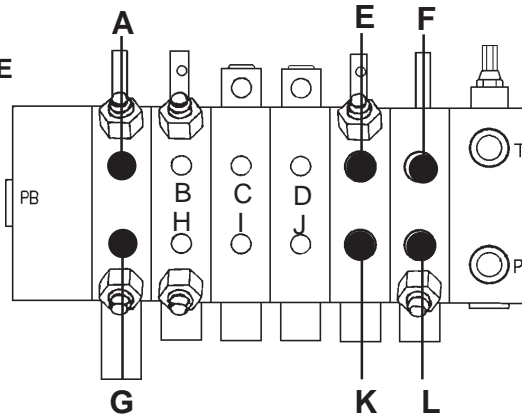

# 3511 BOOM & DIPPER HOSE SET

ASSEMBLY #88528

<u>NO</u>	<u>REQ'D</u>	<u>PART NO.</u>	<u>DESCRIPTION</u>
1	2	37677	Hose Assembly .38" X 95" 6FJX-6FJX
2	1	37738	Hose Assembly .38" X 159" 6FJX-6FJX
3	1	37747	Hose Assembly .38" X 179" 6FJX-6FJX
4	2	37701	Hose Assembly .38" X 157" 6FJX-6FJX

NOTE: Letters on the hose set diagram show the hydraulic hose routing between the backhoe control valve and the various hydraulic cylinders. Simply match the letter on the control valve port to the same letter on the hydraulic hose ends. Example: Hose Assembly labeled "G" runs from the lower Boom port on the hydraulic control valve - through the mainframe and swing post and to the rod end of the boom cylinder.

NOTE: The fittings on the hydraulic cylinders have been altered for clarity purposes. This will assist you in distinguishing between the rod end and the barrel end of the various hydraulic cylinders.

# STABILIZER PADS

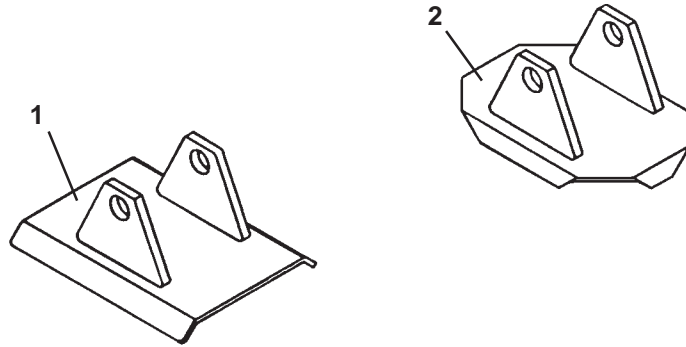

3

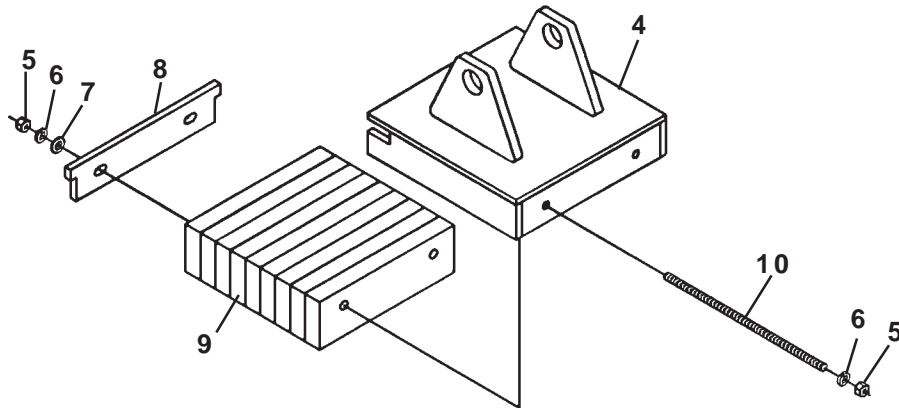

# STABILIZER PADS

<u>NO</u>	<u>REQ'D</u>	<u>PART NO.</u>	<u>DESCRIPTION</u>
<b>FLAT STABILIZER PAD ASSEMBLY - #81861</b>			
1	2	81865	Flat Stabilizer Pad
<b>GROUSER STABILIZER PAD ASSEMBLY - #81860</b>			
2	2	83421	Grouser Stabilizer Pad
<b>RUBBER STABILIZER PAD ASSEMBLY - #81862</b>			
3	2	83418	Rubber Stabilizer Pad Assembly (Includes Items 4 through 10)
4	1	83419	Stabilizer Pad
5	4	1226	.38" UNC Hex Nut
6	4	1503	.38" Lock Washer
7	2	1514	.38" Flat Washer
8	1	51190	Slide Plate
9	1	64412	Rubber Strip Bundle
10	2	1661	.38" UNC X 11.50" Readi Bolt

# STABILIZER PADS

FLIP-OVER STABILIZER PAD ASSEMBLY #83091  
(COMPLETE SET OF (2) FLIP-OVER PADS - ASSEMBLY #83058)

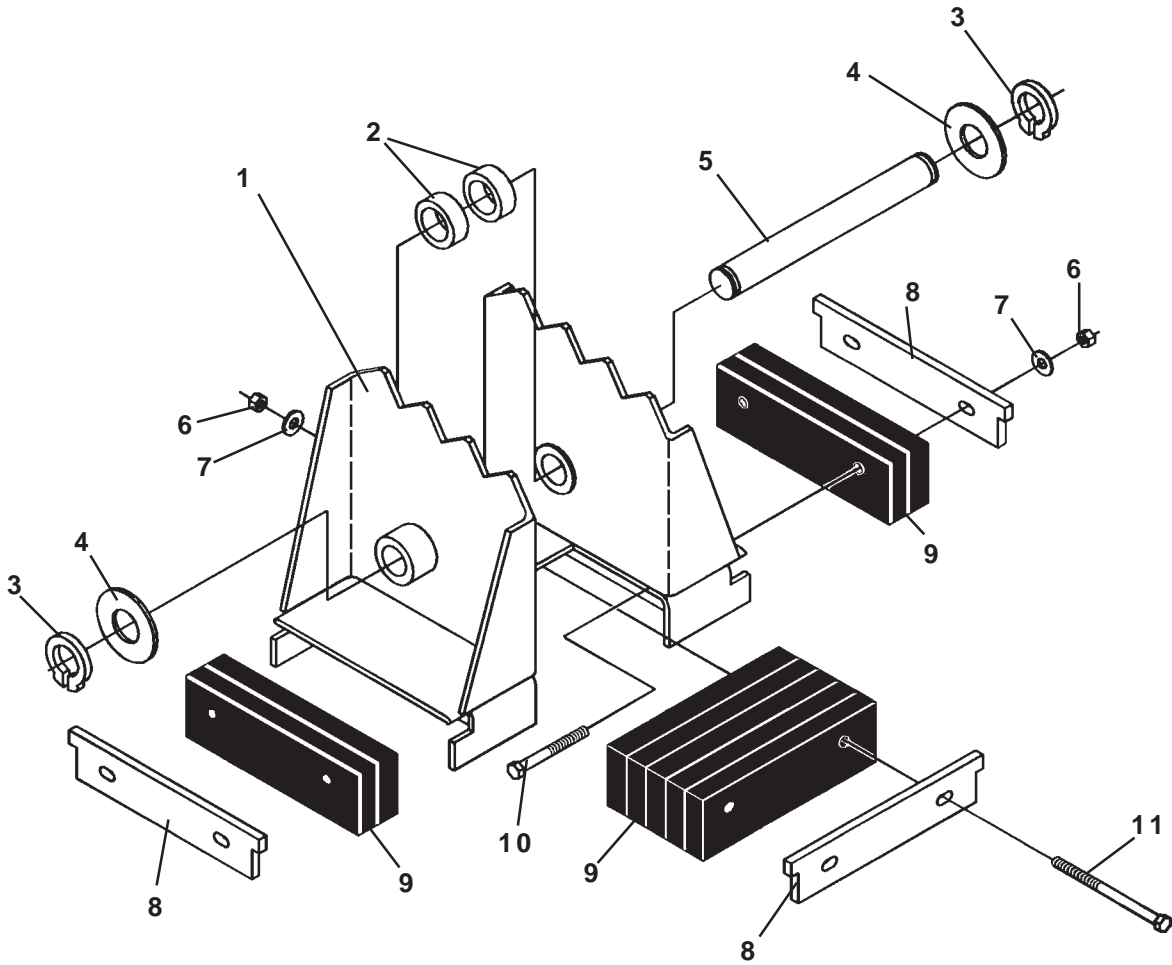

## STABILIZER PADS

FLIP-OVER STABILIZER PAD ASSEMBLY #83091  
(COMPLETE SET OF (2) FLIP-OVER PADS - ASSEMBLY #83058)

<u>NO</u>	<u>REQ'D</u>	<u>PART NO.</u>	<u>DESCRIPTION</u>
1	1	84496	Flip-Over Pad
2	2	84495	Spacer
3	2	1652	1.25" Snap Ring
4	VARIES	57693	Thrust Washer 1.25" X .078"
	VARIES	64727	Thrust Washer 1.25" X .125"
5	1	83096	Pin
6	6	1837	.38" UNC Hex Deformed Lock Nut
7	6	1514	.38" Flat Washer
8	3	51190	Slide Plate
9	1	64412	Rubber Strip Bundle
10	4	1053	.38" UNC X 3.50" Hex Capscrew
11	2	1057	.38" UNC X 5.00" Hex Capscrew

# OPTIONAL STABILIZER CYLINDER COVER

STABILIZER CYLINDER COVER ASSEMBLY #86706

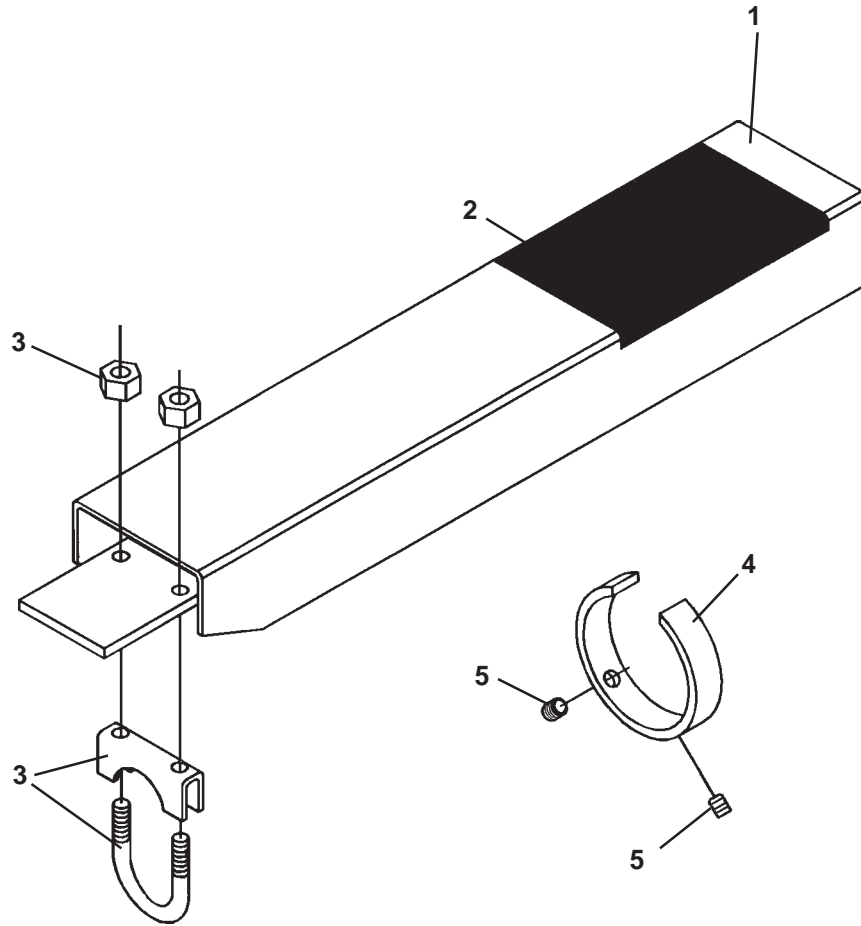



# OPTIONAL STABILIZER CYLINDER COVER

STABILIZER CYLINDER COVER ASSEMBLY #86706

<u>NO</u>	<u>REQ'D</u>	<u>PART NO.</u>	<u>DESCRIPTION</u>
1	2	83915	Stabilizer Cylinder Cover with Decal
2	2	4167	No Step Decal
3	2	83906	1.50" Clamp Assembly
4	2	83911	Guide Ring
5	4	1575	.38" UNC X .50" Set Screw

# BUCKET ASSEMBLIES

## SEVERE DUTY BUCKETS

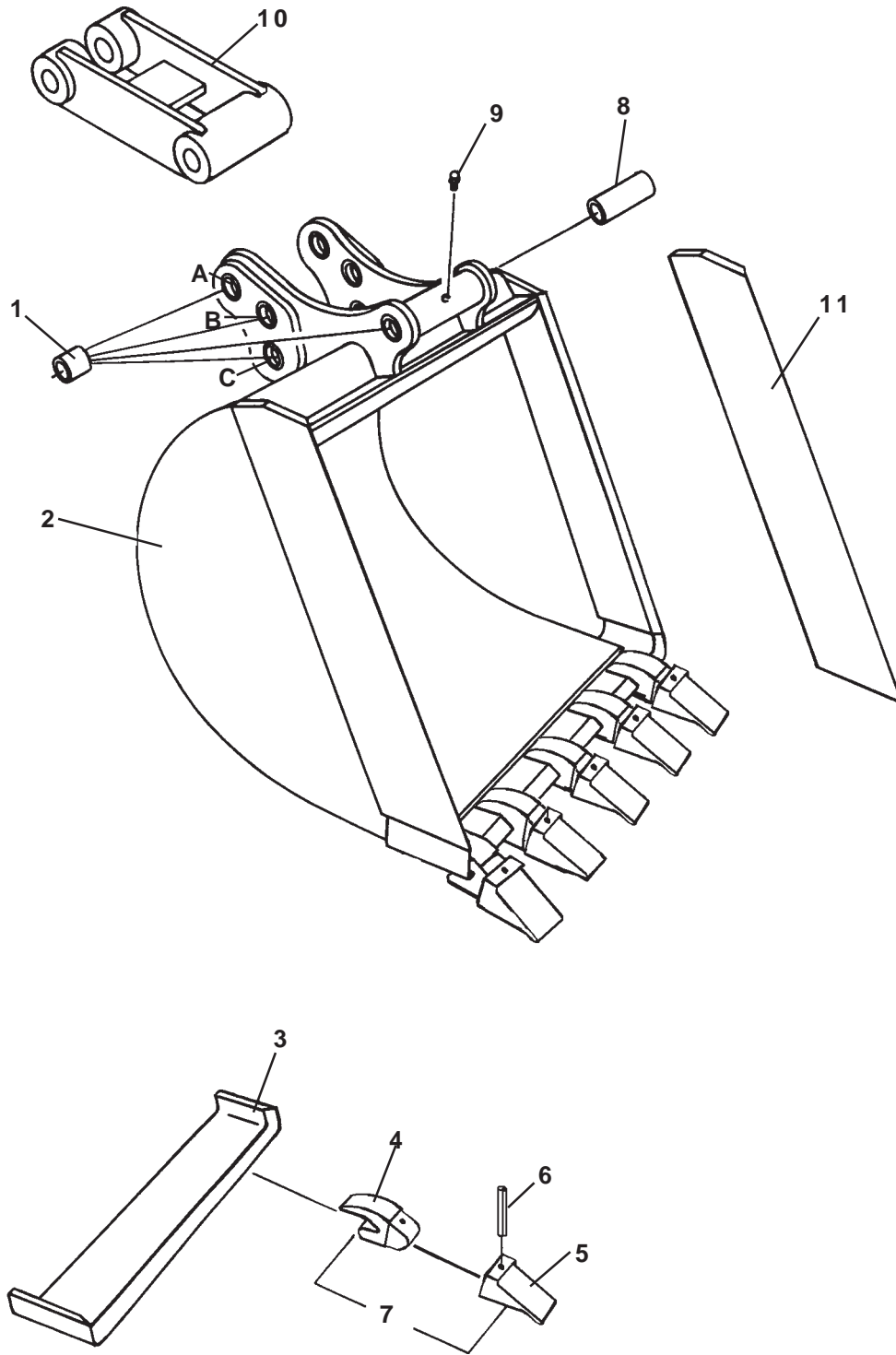

# BUCKET ASSEMBLIES

## SEVERE DUTY BUCKETS

<u>NO</u>	<u>REQ'D</u>	<u>PART NO.</u>	<u>DESCRIPTION</u>
1	8	68043	Bushing (MD2 Series Backhoes)
	8	6355	Bushing (HD, 500 & 600 Series Backhoes)
2	1	85225	12" Bucket Weldment
		85226	16" Bucket Weldment
		85227	18" Bucket Weldment
		85228	20" Bucket Weldment
		85229	24" Bucket Weldment
3	1	85236	12" Replacement Front Cutter Edge
		85241	16" Replacement Front Cutter Edge
		85246	18" Replacement Front Cutter Edge
		85251	20" Replacement Front Cutter Edge
		85256	24" Replacement Front Cutter Edge
4	Varies	74228	Replacement Tooth Shank (Weld On)
5	Varies	84863	Replacement Tooth (Bolt On)
6	Varies	74227	Spiral Roll Pin
7	Varies	85003	Replacement Tooth Point and Shank Assy
8	1	68482	Spacer
9	1	6616	Grease Zerk
10	Optional	82948	Bell Hole Bucket Link (Requires 3 Grease Zerks #6616)
11	1	67151	Left Replacement Side Cutter
	1	67152	Right Replacement Side Cutter

### NOTE:

Severe duty buckets have three different bucket link positions for different digging needs.

Position "A" digging position for added digging force in hard ground.

Position "B" truck loading position for greater ease of spoil removal and higher dump height.

Position "C" standard digging position with a good balance of digging force and bucket rotation for general digging use.

# 3509 FIRST LINE REPAIR KIT

ASSEMBLY #88673

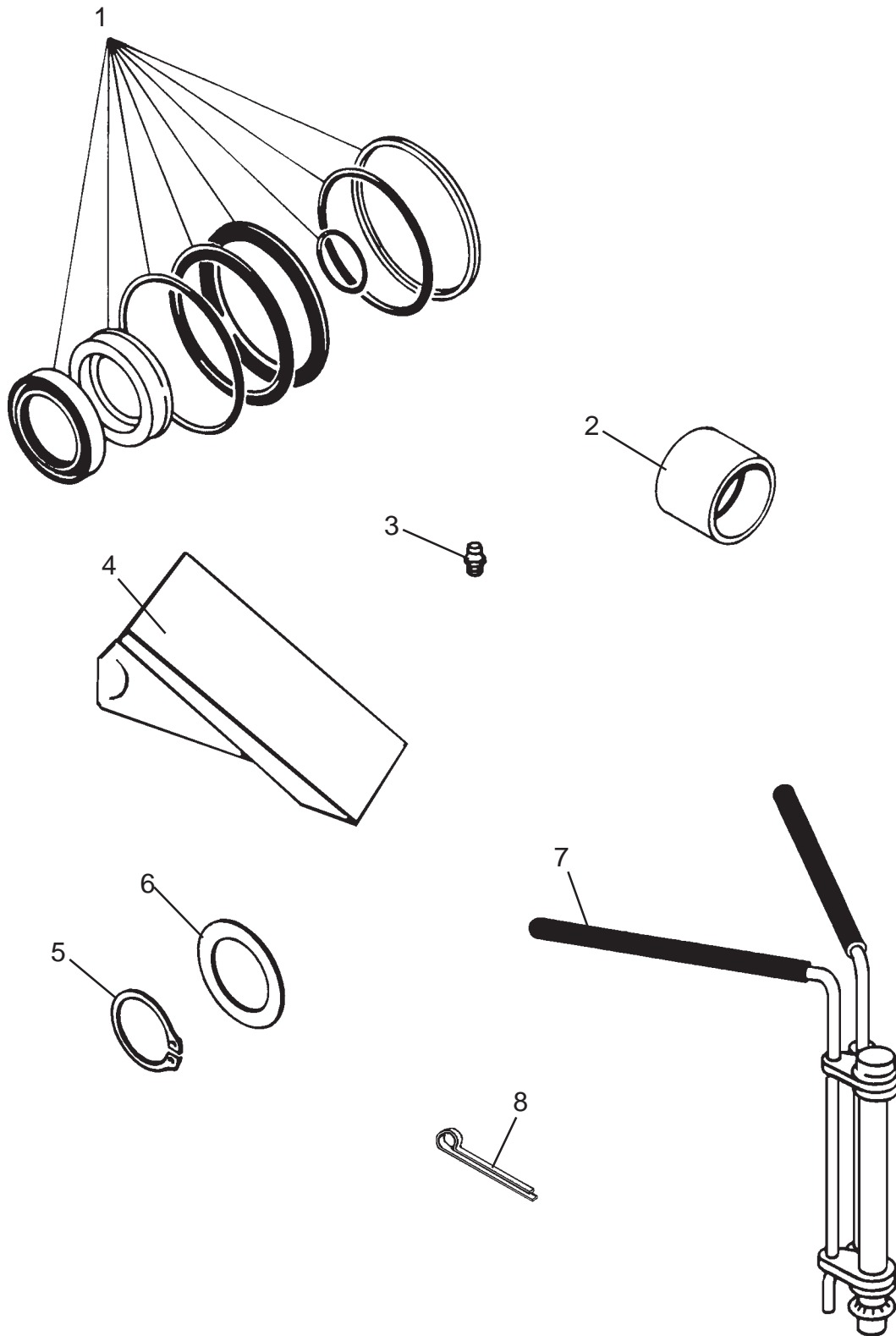

8077  
3-1-00

# 3509 FIRST LINE REPAIR KIT

ASSEMBLY #88673

<u>NO</u>	<u>REQ'D</u>	<u>PART NO.</u>	<u>DESCRIPTION</u>
1	1	45753	Seal Kit (Boom Cylinder)
	1	45542	Seal Kit (Bucket Cylinder)
	1	45541	Seal Kit (Dipper Cylinder)
	1	45738	Seal Kit (Stabilizer Cylinders)
	1	45617	Seal Kit (Swing Cylinder)
2	2	6355	Bushing
3	4	6616	Grease Zerk
4	4	84863	Bucket Tooth Point
5	4	1650	Snap Ring 1.38"
	2	1652	Snap Ring 1.25"
6	4	6623	Thrust Washer 1.38" X .031"
	4	64728	Thrust Washer 1.25" X .031"
7	1	65349	Cylinder Seal Install Tool
8	2	1613	Cotter Pin

# 3511 FIRST LINE REPAIR KIT

ASSEMBLY #88627

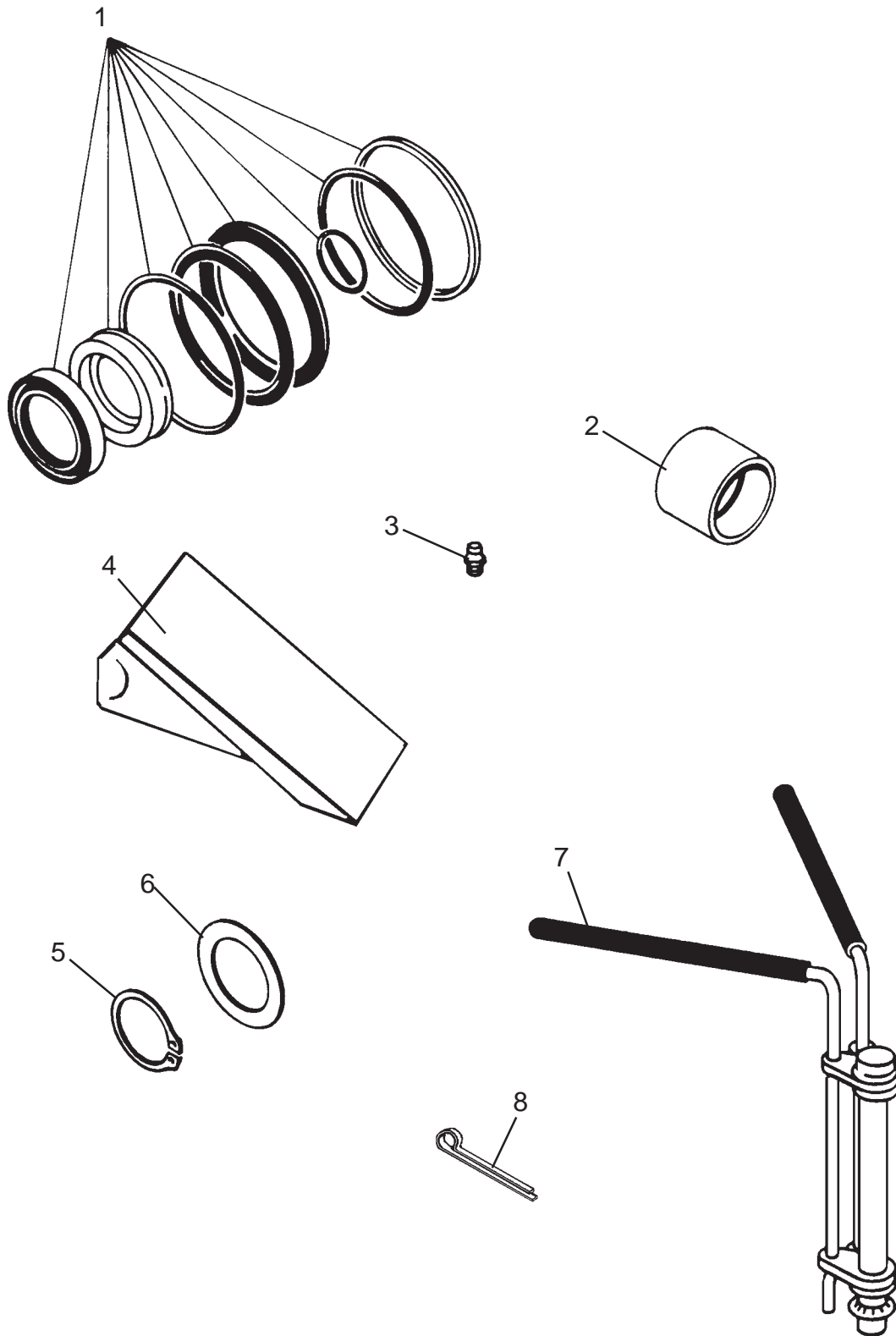

# 3511 FIRST LINE REPAIR KIT

ASSEMBLY #88627

<u>NO</u>	<u>REQ'D</u>	<u>PART NO.</u>	<u>DESCRIPTION</u>
1	1	45539	Seal Kit (Boom Cylinder)
	1	45542	Seal Kit (Bucket Cylinder)
	1	45541	Seal Kit (Dipper Cylinder)
	1	45738	Seal Kit (Stabilizer Cylinders)
	1	45617	Seal Kit (Swing Cylinder)
2	2	6355	Bushing
3	4	6616	Grease Zerk
4	4	84863	Bucket Tooth Point
5	4	1650	Snap Ring 1.38"
	2	1652	Snap Ring 1.25"
6	4	6623	Thrust Washer 1.38" X .031"
	4	64728	Thrust Washer 1.25" X .031"
7	1	65349	Cylinder Seal Install Tool
8	2	1613	Cotter Pin

**THIS PAGE  
IS INTENTIONALLY  
BLANK**



# DECALS

## DECAL PLACEMENT

### GENERAL INFORMATION

The diagrams on this page shows the location of all the decals used on the 3509 & 3511 backhoes. The decals are identified by their part numbers, with reductions of the actual decals located on the following pages. Use this information to order replacements for lost or damaged decals. Be sure to read all decals before operating the backhoe. They contain information you need to know for both safety and backhoe longevity.

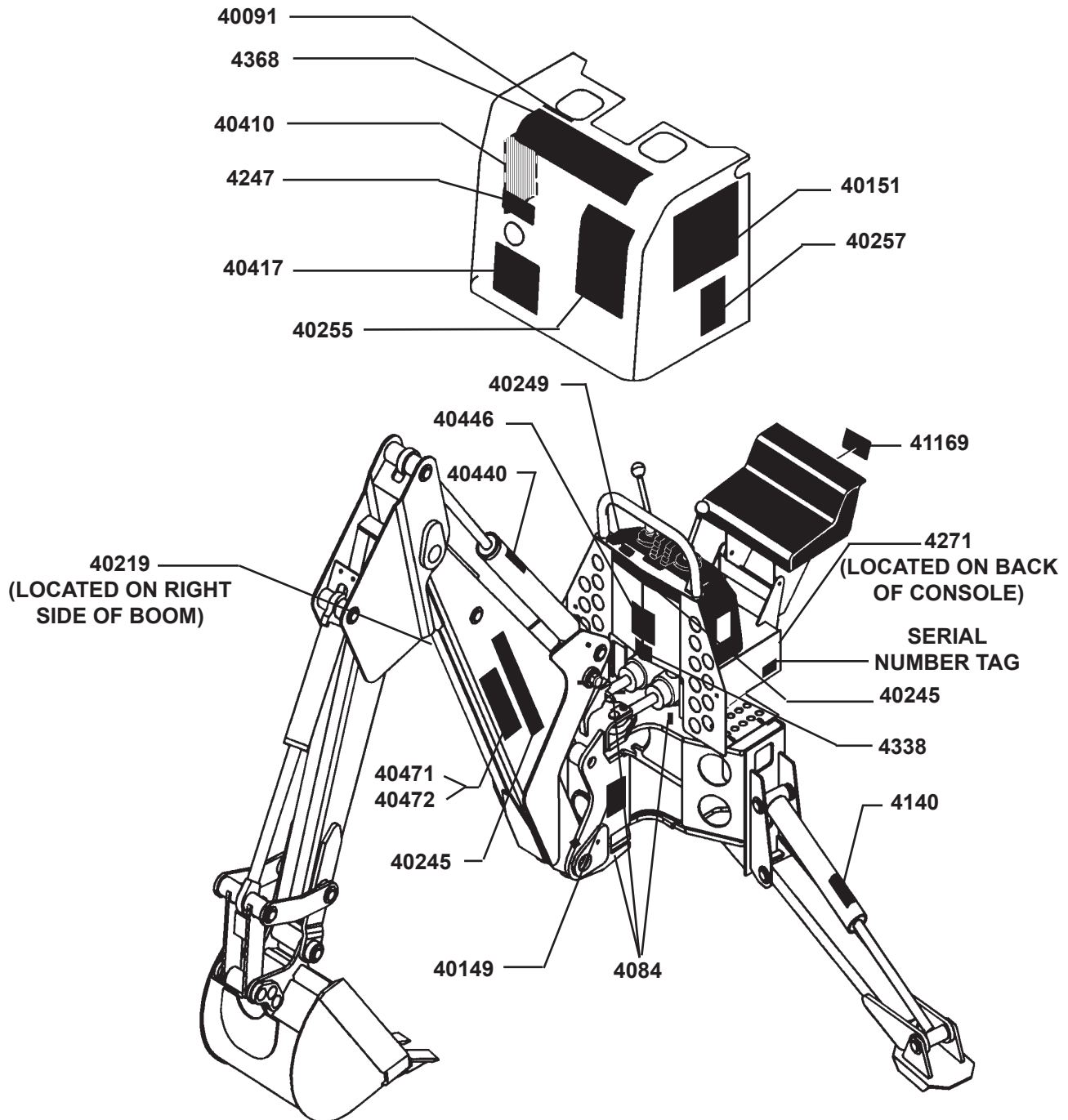

## DECALS



PART #40151  
HIGH PRESSURE FLUID DECAL



PART #41169  
DANGER! BACKHOE SECURE

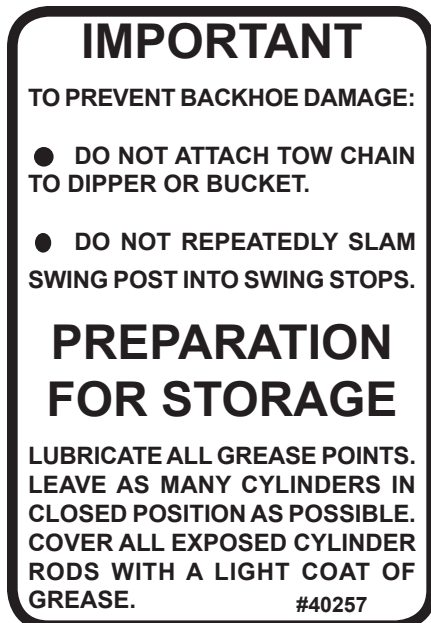

PART #40257  
IMPORTANT! DECAL

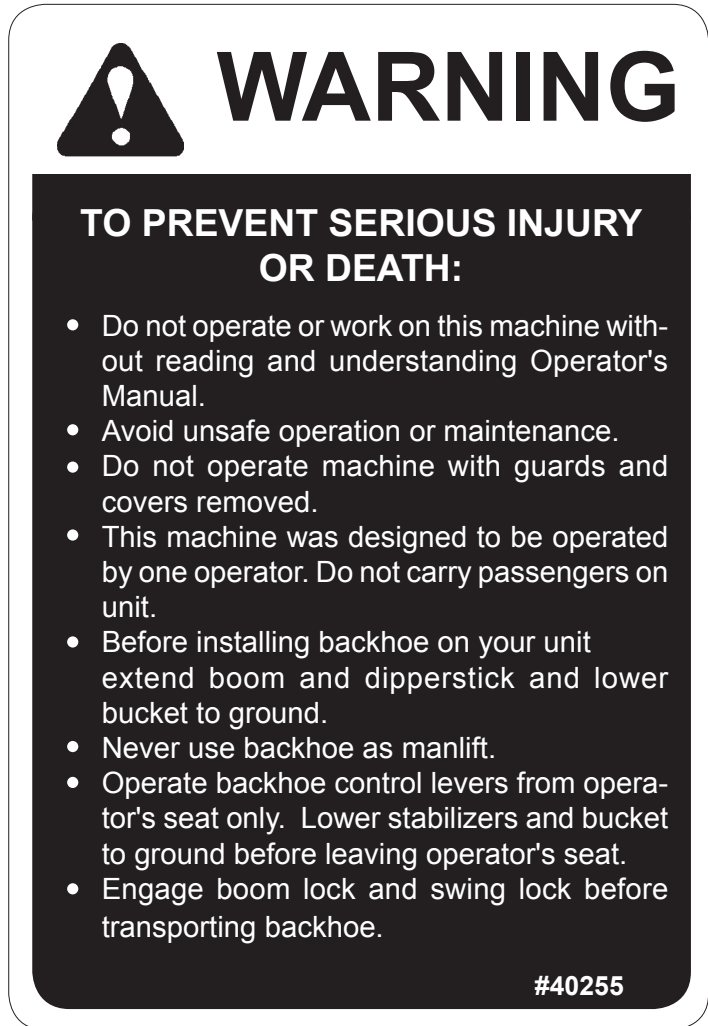

PART #40255  
OPERATIONAL WARNING DECAL



PART #40149  
DANGER! PINCH POINTS

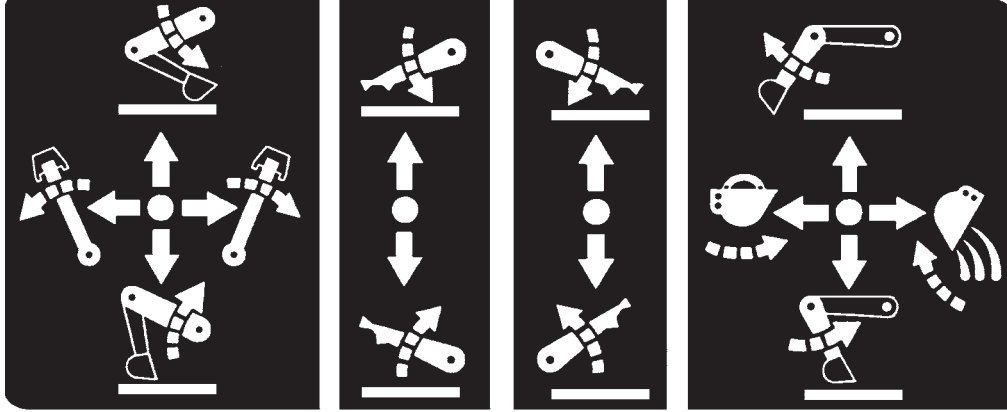

PART #4368  
OPERATING CONTROLS DECAL



PART #40091  
FLOAT DECAL



PART #4247  
SWING SPEED CONTROL DECAL

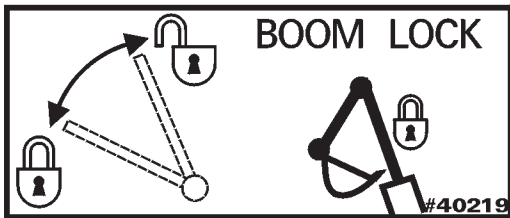

PART #40219  
BOOM LOCK DECAL

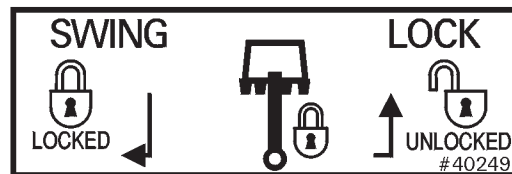

PART #40249  
SWING LOCK DECAL

# IMPORTANT

The backhoe bucket is capable of contacting this stabilizer and/or cylinder. Careful operation will avoid backhoe damage.

#4140

PART #4140  
BUCKET CONTACT WARNING DECAL



PART #4338  
MADE IN U.S.A. DECAL



PART #40440  
CALL BEFORE YOU DIG

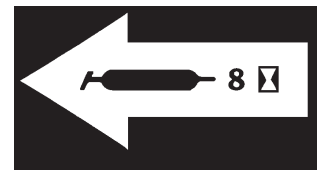

PART #4084  
GREASE 8 HOURS



PART #40446  
 CAUTION! BACKHOE LIMITATIONS

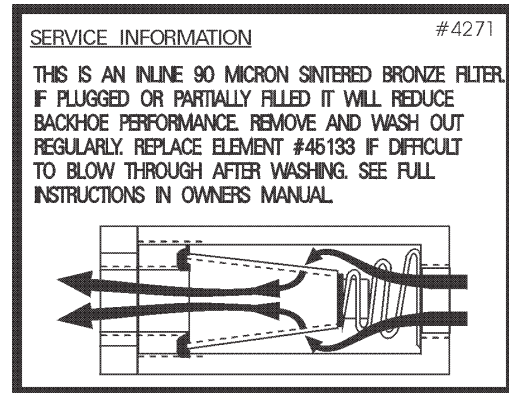

PART #4271  
 INLINE FILTER DECAL

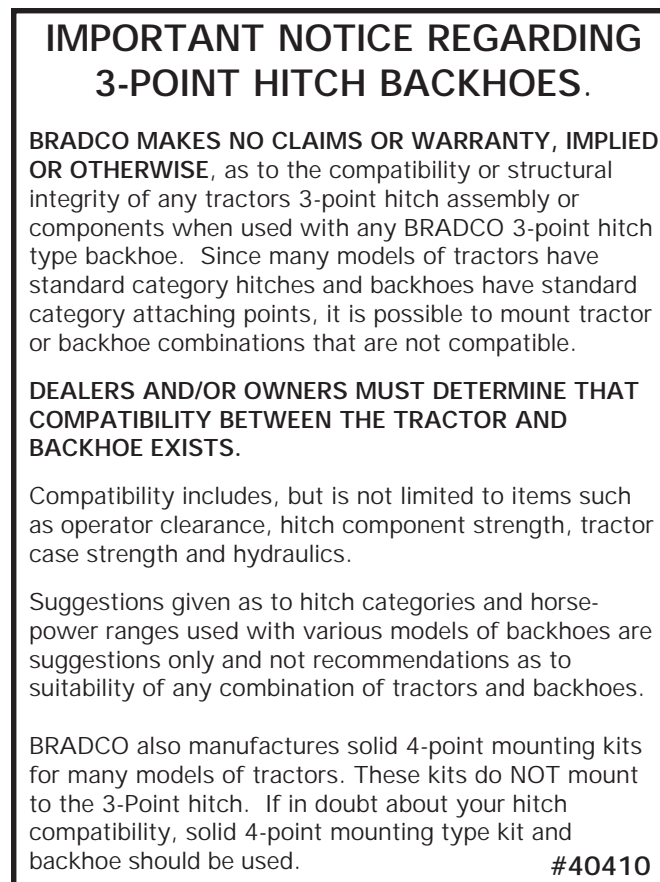

PART #40410  
 IMPORTANT NOTICE

# BRADCO

PART #40245  
BRADCO LOGO - SILVER

# 3509

PART #40471  
3509 MODEL NUMBER

# 3511

PART #40472  
3511 MODEL NUMBER

## **WARNING**

### **TO AVOID SERIOUS INJURY OR DEATH.**

- Use **ONLY** on Category II tractors.
- Do not use 3-point quick attaching coupler to mount backhoe on tractor.
- Minimum of 20% of tractor and equipment weight must be on the tractor front wheels with the backhoe in the transport position.
- Operate PTO at 540 RPM (if so equipped).
- Backhoe digging forces can lift and turn tractor over. Make sure stabilizer pads are on firm ground and avoid steep banks.
- Do not exceed ROPS certification weight.
- Consult local utilities before digging. Know location of and avoid contacting all underground cables, pipelines, overhead wires and other hazards in digging area. #40417

PART #40417  
**WARNING!**