

ASSEMBLY, SERVICE & OPERATION MANUAL

GEARMORE INC.

VENTURI AIR SPRAYERS



3-POINT MODELS

June 2013

Dear Customer:

Congratulations for choosing a Gearmore Venturi Air Sprayer. This equipment has been designed and manufactured to meet the needs of a discriminating buyer for the efficient spraying operations you may require.

Through our research and development department, we are continuously testing our sprayers which allows us to offer the best performance, highest reliability and ease of use of any sprayers on the market today. We are constantly striving to stay ahead of competition in developing the latest technology and utilizing it on our sprayers.

Our primary goal is customer satisfaction.

Venturi Air Sprayers

3-point hitch models

Model:

Serial Number:

Please fill out for future reference

OPERATION AND MAINTENANCE INSTRUCTIONS

GEARMORE INC.

13477 Benson Ave. • Chino, CA 91710
Ph: 909.548.4848 • Fax: 909.548.4747
www.gearmore.com

TABLE OF CONTENTS

<u>SECTION</u>	<u>DESCRIPTION</u>	<u>PAGE</u>
1	Forward	1
1.1	Introduction	1
1.2	Using The Manual	1
2	Glossary.....	2 - 4
2.1	Terminology	2
2.2	Decals	2-4
3	General Information	5 - 9
3.1	Machine Identification.....	5
3.2	Technical Assistance.....	5
3.3	Safety Notices.....	5
3.3.1	General.....	5-6
3.3.2	Precautions Against Fires.....	6
3.4	Safety Systems	7
3.5	Handling of Agro-Chemicals	7-8
3.5.1	Storage.....	8
3.5.2	Specific Equipment	8
3.5.3	Disposal of Empty Containers & Chemicals.....	8-9
3.5.4	Personal Protection	9
4	Machine's Structural Analysis	10 - 20
4.1	Frame.....	11
4.2	Overrunning Clutch.....	12
4.3	Liquid Circuit	13
4.3.1	Operating Principle	13-14
P1	Tank	15
P22	Handwashing Tank.....	15
P2	3-Way Lever Valve	15
P4	Centrifugal Pump	16
P6	3-Way Valve	16
P7	Filter.....	17
P8	Gauge	17
E10	Control Unit.....	17
E9	Electrical Distributor	17
P12	Powder Mixer Lever Valve	18
P13	Powder Mixer	18
P9	Manual Distributor.....	19

<u>SECTION</u>	<u>DESCRIPTION</u>	<u>PAGE</u>
P11	Calibration Disc	20
5	Mounting to 3-Point Hitch	21
5.1	Mounting of PTO Shaft.....	21
6	Distribution Devices	22
6.1	Positioning of Fan Casing Housing	22
6.2	Elbow Fittings of Distribution Head	22
7	Accessories	23
7.1	Pair of Wheels.....	23
7.2	Swivelling Device.....	23
8	Agitation.....	24
9	Operating Procedures	25 - 27
9.1	Preparatory Operations	25
9.2	Treatment.....	26
9.3	End of Treatment - Storage.....	27
10	Cleaning & Storage.....	28
11	Lifting & Transport	29
12	Maintenance Operations	30 - 35
12.1	Lubrication.....	30
12.2	Fan Shaft Support Oil Level Check.....	31
12.3	Fan Shaft Support Oil Replacement.....	31
12.4	Cleaning of Filter's Cartridge	32
12.5	Purging of Residues From Filter.....	32
12.6	Fan Belt Tensioner	33
12.7	Pump Belt Tensioner	33
12.8	Tank Removal or Replacement.....	34
12.9	Maintenance Schedule.....	35
13	Troubleshooting Chart	36 - 37
14	Repairs Allowed	38 - 41

<u>SECTION</u>	<u>DESCRIPTION</u>	<u>PAGE</u>
14.1	Replacement of Pump Control Belt.....	38
14.2	Replacement of Electrical Panel's Fuses.....	39
14.3	Pressure Gauge Replacement	39
14.4	Cleaning & Inspection of Pump Filter	40
14.5	Level Gauge Cleaning	41
15	Integrative Diagrams	42
16	Limited Warranty	43

1.1 INTRODUCTION

We welcome you as an owner of the Gearmore Venturi Air Sprayer. This sprayer has the latest technical features and benefits that today's market demands. Yet, the sprayer is quite simple to use and maintain. Before you read on to the operation and maintenance of the sprayer, please read the following general information.

POWER SOURCE: The sprayer is designed to mount to any 540 RPM tractor with the correct PTO horsepower.

PUMP: The pump on the sprayer is a low pressure centrifugal type. There is one very important point to remember with centrifugal pumps; the pump uses the liquid to cool itself. Thus, if you run the pump dry, it will be damaged quickly.

TANK: The tank is thick walled polyethylene, which is corrosion resistant to most chemicals.

BLOWER: Air is supplied by a centrifugal fan. The fan is made of steel and is precision balanced for smooth operation. A special overrunning clutch is mounted on the blower assembly to prevent damage.

CLUTCH: A special overrunning clutch is standard equipment. This clutch will prevent damage to the sprayer and tractor when the PTO is disengaged.

AGITATION:

1. The 3-point hitch sprayers are equipped with a dual agitation system, a liquid system that uses by-pass liquid from the pump and an air system that uses air from the fan housing.

1.2 - USING THE MANUAL

Read every part of this manual, paying attention to the **WARNING** and **DANGER** indications both on the text and on the machine or on components.

All operations suggested by the manual will have to be followed with the utmost care and only after having understood the negative consequences of improper usage.

The following "**symbols**" are used within the text in order to highlight and visually identify the importance of the various types of information:



Indicates important additional information.



Non observance can result in permanent damage to the sprayer.



Highlights possibly dangerous situations to people.



- The manual must always be kept for the sprayer's whole operational life.
- Any modification received must be permanently inserted in this publication.
- The manual must accompany the sprayer should this unit be sold

2.1 - TERMINOLOGY

The terms FRONT, REAR, RIGHT and LEFT utilised in this publication refer to the sprayer as seen by an operator from behind the operative unit along the drive line and facing it: **the rear part** of the machine is that closest to the operator, and is where the distribution device (Head) is mounted - and **the front part** is the one that gets attached to the tractor.

2.2 - DECALS

The safety and use/maintenance decals are applied to the machine are described in the following paragraph.



Every decal is marked with its part number, in case it needs to be replaced.

Safety decals



95001

- STOP THE ENGINE AND REMOVE THE KEY FROM THE TRACTOR'S CONTROL PANEL BEFORE CARRYING OUT ALL MAINTENANCE OR REPAIR OPERATIONS
- CONSULT THE USER AND MAINTENANCE MANUAL BEFORE USING OR INTERVENING ON THE MACHINE



95098

- CONSULT THE USER AND MAINTENANCE MANUAL BEFORE USING THE MACHINE
- DANGER OF CONTAMINATION BY CONTACT OR POISONOUS PRODUCTS INHALATION
- IT IS FORBIDDEN TO ENTER INTO THE TANK!



95005

- DANGER, PARTS IN MOTION. BEFORE REMOVING PROTECTION GUARDS, STOP THE TRACTOR, REMOVE THE KEY FROM THE TRACTOR'S CONTROL PANEL AND ENSURE THAT ALL MOVING PARTS HAVE STOPPED



95012

- DANGER: MOUNT THE WHEELS AFTER HAVING HITCHED THE MACHINE TO THE HOISTER AND DISMANTLE THEM BEFORE UNHITCHING THE MACHINE FROM THE HOISTER



95010

- MAXIMUM OPERATING SPEED OF THE DRIVE OUTLET (PTO): 540 RPM



95015

- BEFORE UTILISING THE RELEASE DEVICE, STOP THE TRACTOR, REMOVE THE KEY FROM THE TRACTOR'S CONTROL PANEL AND ENSURE THAT THE FAN HAS STOPPED

Use and maintenance decals



95079

- CHECK THE OIL LEVEL EVERY 8 HOURS: FAN SHAFT BEARINGS.



95009

- DANGER: GLOVES MUST BE USED TO EMPTY THE TANK



95077

- HANDWASHING TANK TAP
Imprint next to the tap.

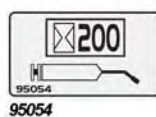

95054

- GREASE EVERY 200 HOURS: FAN TIGHTENER SUPPORT AND FREEWHEEL

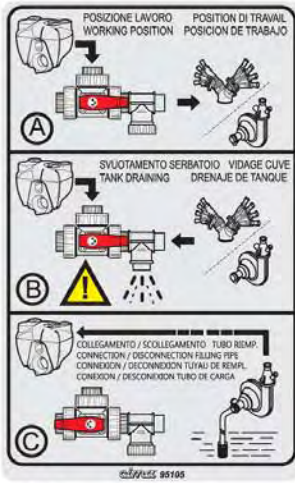

95105

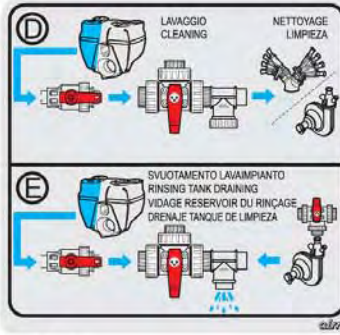

95104

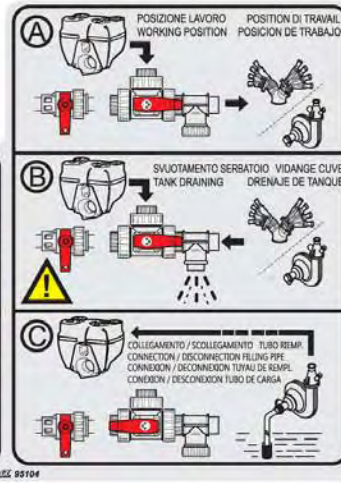

- INDICATION ON THE OPERATION OF THE 3-WAY TAP (P2)



95059

- HOOKING POINT FOR THE LIFTING OF THE MACHINE



95102

- INDICATION OF THE CHEMICAL EMPLOYED FOR THE TREATMENT

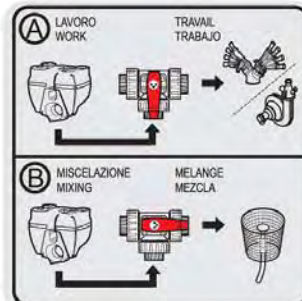

95058

cima

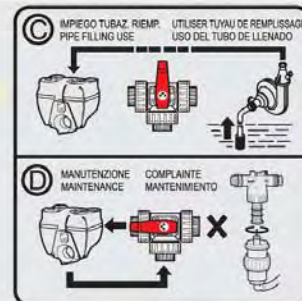

95058

- INDICATION ON THE OPERATION OF THE 3-WAY TAP (P6)



95056

- INDICATION OF THE WHEELS OPERATING PRESSURE (accessory)



95065

- WARNING: NEVER OPERATE THE SPRAYER WITHOUT LIQUID IN THE TANK

Positioning of the safety, use and maintenance decals

NOTE: The numbers with the asterisk (*) indicate the adhesives relevant either to optional components or to accessories to be applied ONLY on the models and versions on which it is foreseen.

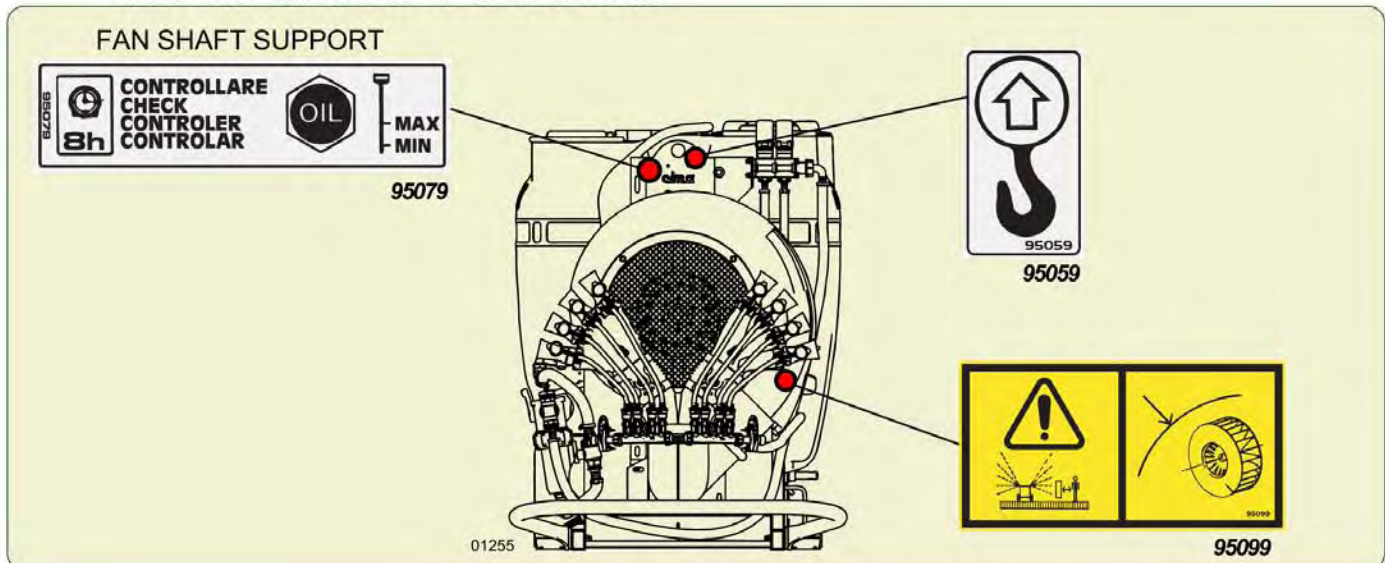



95001

cima
 NON FARE MAI FUNZIONARE
 L'ATOMIZZATORE SENZA LIQUIDO
 NEL SERBATOIO.
 PUMP MUST
 NOT RUN DRY
 JAMAIS FAIRE FONCTIONNER LE
 PULVÉISUR SANS LIQUIDE DANS LE
 RÉSERVOIR.

95065



95098

OVERRUNNING
 CUT-OFF



95054 (*)



95009

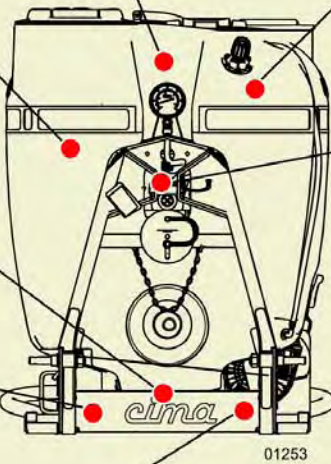

01253



95015 (*)

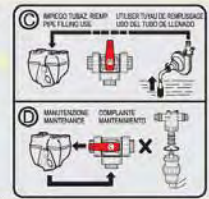
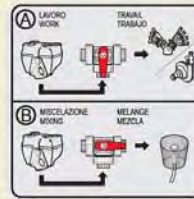

95058



95010



95102

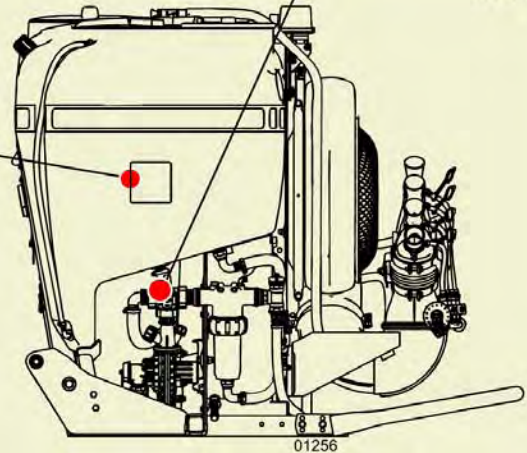

01256



95057

FAN
 TIGHTENER
 SUPPORT



95054

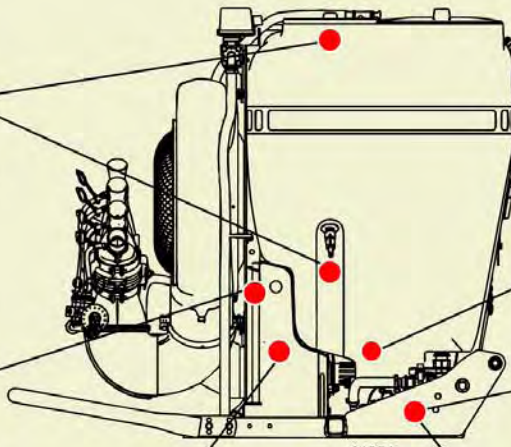

01254



95012



95056 (*)

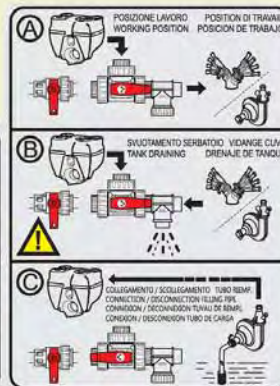
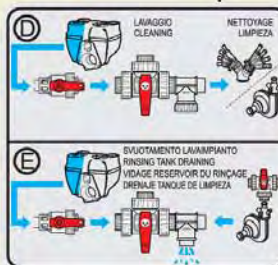

95105 (*)

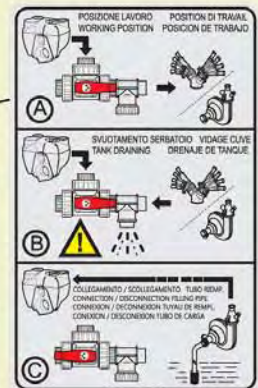

95104 (*)

(*) Optional

For models with rinsing tank

3.1 - MACHINE IDENTIFICATION

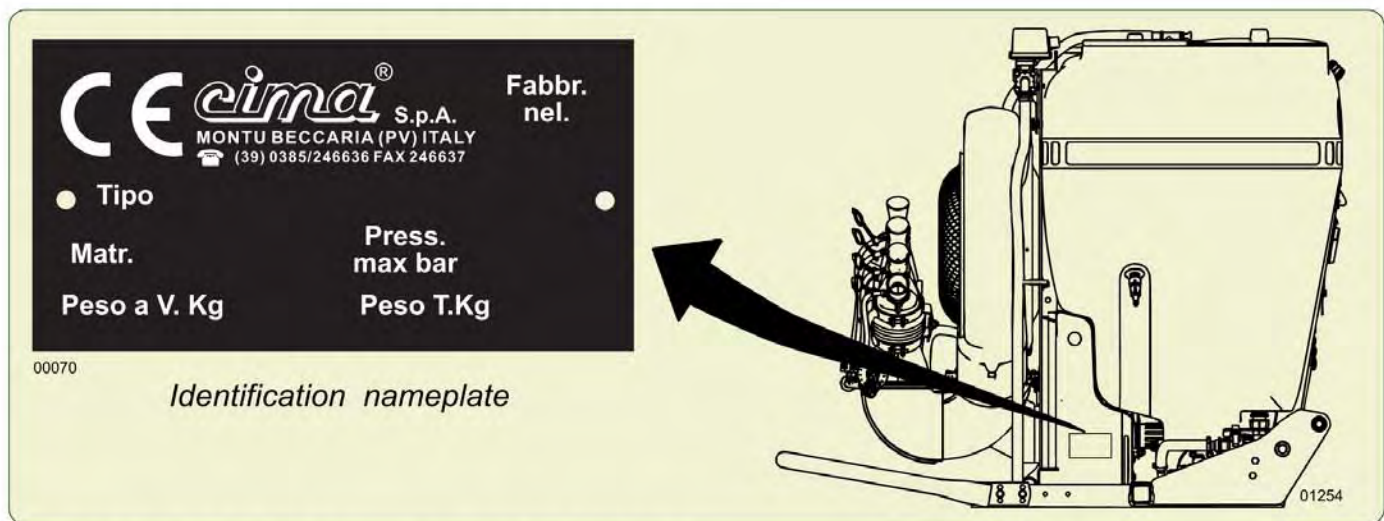

3.2 - TECHNICAL ASSISTANCE

Please see your local dealer or contact Gearmore.

13477 Benson Ave. - Chino, CA 91710
Ph: 909-548-4848

3.3 - SAFETY NOTICES

3.3.1 - General



The personnel appointed to the use of the machine must have acquired an exhaustive knowledge of the same one and of the dispositions contained inside this publication, be able to properly interpret the symbols of the adhesives applied on the machine, and, in addition, perfectly know the safety and the work hygienic rules in force in the country where the machine itself is to be used.

All the preparation, use, maintenance, moving and transporting operations must be carried out of the regulations contained in this publication.



IT IS FORBIDDEN TO UTILISE THE SPRAYER FOR PURPOSES OTHER THAN FOR ITS INTENDED USE, SINCE IT WAS MANUFACTURED ONLY FOR SPRAYING AGRICULTURAL CROPS WITH ANTI-PARASITIC PRODUCTS.

It is necessary to scrupulously abide by the following general norms:

- check that the power of the tractor is compatible with the sprayer to be used;
- verify that the maximum weight admitted on the three-point hoister of the tractor is compatible with the weights of the sprayer to be used;



On the identification plate, the full-load weight of the machine is indicated, measured WITHOUT the distribution device.

- before utilisation, check the correct tightening and securing of the machine's various components, paying particular attention to the safety protections and to the moving parts;
- only utilise protected PTO shafts.
Carry out the assembly only if the drive outlets of both tractor and sprayer are equipped with the protection counter-guard;
- check that the PTO shaft is blocked by the appropriate anti-rotation chains;
- keep people and animals away from the machine before starting it up;
- don't wear articles of clothing that might get caught in moving parts;
- keep to a low speed while negotiating bumps or crossing ditches;
- during the use of the machine, the operator must have a sufficiently good visibility on the working areas, consequently it is recommended to keep both clean and efficient the cab windows and the rear-view mirrors;
- always stop the tractor's engine and actuate the parking brake before carrying out any operation on the sprayer;
- never leave the machine unguarded, when the key is inserted inside the tractor control panel;



- **All maintenance and repair operations must be carried out only after having rinsed the tank and flushed the system.**
- **Before operating within the tank it is necessary to wash it thoroughly with clean water.**
- **The application of paints and/or solvents, the washing of closed environments and machinery as well as the utilisation of the air flow for purposes other than those expressly concerning the spraying of agro-chemicals is not permitted.**
- **It is forbidden to enter the tank.**

3.3.2 - PRECAUTIONS AGAINST THE FIRES

Don't approach either flames or heat sources to the machines. The materials used for manufacturing the machine itself are widely made by oil derivatives: tanks, pipes, tires, plastic components; besides, the presence of lubricants and of chemical product residuals make them potentially flammable.



- **It is forbidden to carry out weldings, if ammonium salts have been used.**
- **It is forbidden to use the machine within a potentially explosive environment.**

3.4 - SAFETY SYSTEMS

All machine moving parts are suitably protected by guards and highlighted through the use of warning decals.



- It is forbidden to use the machine with these guards removed.
- Before removing the protection, stop the tractor's engine and remove the key from the control panel.

The pictures illustrate the machine's guarded parts:

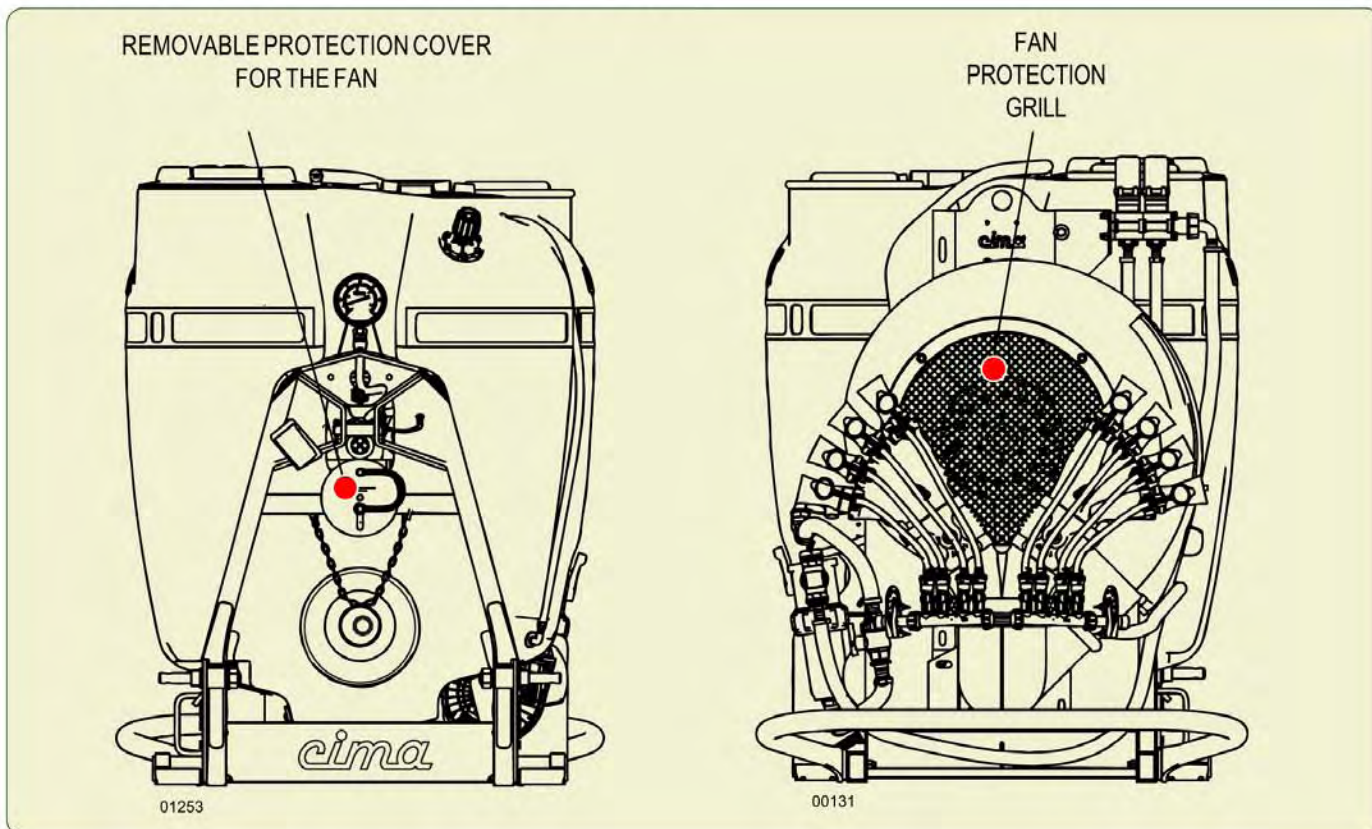

THE OWNER AND/OR THE OPERATOR OF THE SPRAYER ARE NOT PERMITTED TO MODIFY THE STRUCTURE OR THE SPECIFIC OPERATION OF THE SPRAYER ITSELF.

3.5 - HANDLING OF AGRO-CHEMICALS

The **operator** could become contaminated due to accidental spray, contact or inhalation of products or crop-spraying mixtures.

The **environment** could become polluted by mixture over-spills, puncturing of containers, uncontrolled storage of used and unwashed containers or spillage into waterworks.

In order to avoid these risks the preparation and filling operations must be carried out in suitably appointed and adequately equipped sites.



To use pesticides (purchase, transport, loading, treatment planning, mixture preparation, field transfert, treatment performance, ending treatment liquid waste management, equipement rinsing and waste disposal) you must follow the country rules.



Absolutely respect the rules on the label of the product used referring to the application per acre.

3.5.1 - Storage

Fixed / stationary: the site used must be well ventilated and secured by lockable doors in order to prevent even accidental access by children or unauthorised persons.

Mobile: the carrier equipment must be properly locked and kept under conditions whereby access by children or unauthorised persons can be prevented during the absence of the operator. All full or partially utilised containers must be secured against tipping, falling or breakage during transportation.

Both types of storage must:

- have a suitable container for the storing of empty packaging materials should a specific storage area not be available;
- have a clean water supply readily available for washing, by means of a specific container or through connection to the waterworks system;
- have the use of fire extinguishers, should flammable products and substances be stored.



- All packages, whether whole or partially utilised, must be stored in their original packing and with the warning instructions clearly displayed and legible.

- The storage indications must always be scrupulously adhered to, as well as their utilisation and possible disposal as suggested on the product's original packaging.

3.5.2 - Specific equipment

The site at which the preparation and filling out will take place must provide for:

- all the equipment necessary to the precise measuring of both the water quantity and the dose of product to be mixed in the tank at every filling;
- all the equipment and means useful to the preparation of the mixture and for the cleaning of the operator in case of contamination;
- all tools necessary to facilitate the direct introduction of the agro-chemicals in the tank;
- the allocation of clothing and specific equipment in order to avoid contamination by contact or inhalation during the whole operative phase of the intervention;
- the availability of proper equipment able to stop the uncontrolled spilling and flowing of the mixture;
- a retaining valve on the feed pipe when the filling of the tank takes place directly from the waterworks system.

3.5.3 - Disposal of empty containers and agro-chemicals residues

Agro-chemicals are classified as "special" waste and their disposal must take place separately from "urban" wastes.



Empty packaging and contaminated containers to be done away with cannot be dispersed, burned or buried.

The washing water for the cisterns and the tools utilised for the preparation of mixtures cannot be emptied on the ground, spilled into the sewage system or in waterways and rivers.

The disposal of special wastes is regulated by specific norms. In order to perform this operation it is necessary to obtain the relevant information from the Local Offices specifically appointed to rule on this subject. The non compliance with these regulations can cause considerable damage to persons and animals as well as polluting the environment.

3.5.4 - Personal Protective Equipment (PPE)

The use of phytosanitary products might imply a more or less high chemical risk for the workers on the basis of the toxicity and the dangerous properties of the phytosanitary product, of the level and duration of the exposure, of the absorption level through the respiratory tract, the skin, the mucosa and the ingestive tract, as well as the way and frequency of the use.

The “personal protective equipment” (PPE) are equipment that all the users of the machine need to wear and hold in order to be protected by one or more risks that are capable to treat the security or healthy during the job.

Regarding the basic requirements, PPE have to:

- be suitable to the risks that have to be prevented, without causing major risks themselves;
- be suitable to the existing conditions on the workplace;
- consider the ergonomic (easily adaptable, easy to wear and safe) or health needs for any users;
- be adaptable to the user according to his/her needs.

The PPE for the protection against dangerous chemical agents used for the operations that concern the exposition to phytosanitary products , pertains to the third class (3rd class – 0000).



Use solely PPE equipped with the needed CE mark, in the scrupulous respect of the regulations in force in the country where the machine is in use and adequate to the phytosanitary product used.

It's needed to use the PPE in each of the following working stage:

- tank filling and addition of the phytosanitary product;
- spraying,
- calibration of the sprayer,
- draining and cleaning of the tank,
- phytosanitary product replacement,
- servicing.

The following must be worn:

- for the protection of the body (gloves, suits, boots),
- for the protection of the respiratory tract, of the head and of the eyes (helmet, masks, filters, glasses, hoods and headdresses).



Filters must be replaced following the producers' instructions, and in any case:

- in case a bad smell is noticed;
- in case a resistance to the respiratory function is noticed;
- at least once a year in case of occasional use.

For ALL PPE in use, follow the use instruction declared by the PPE producers.



00073

The pictures indicate the position of the main components of the sprayer.

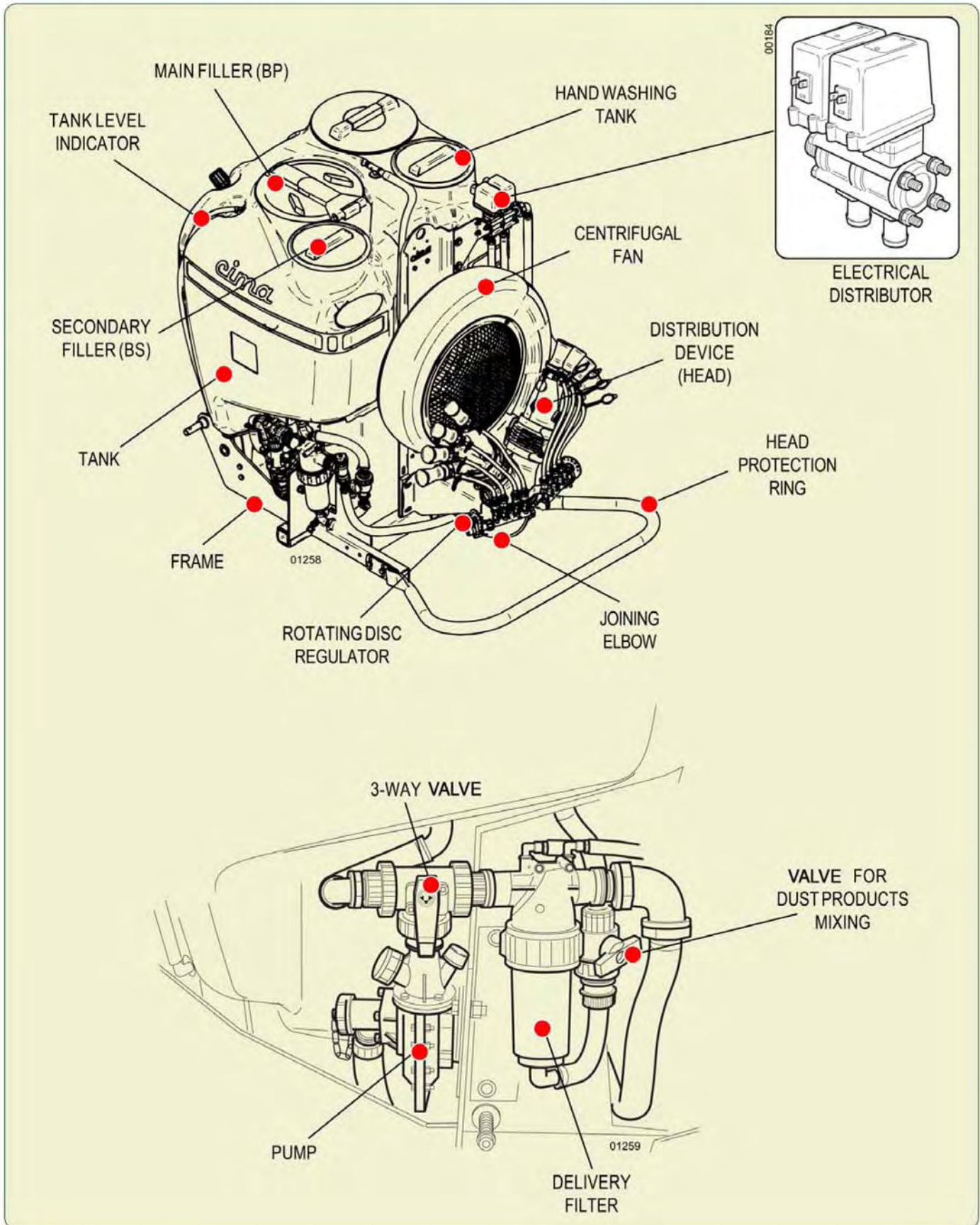

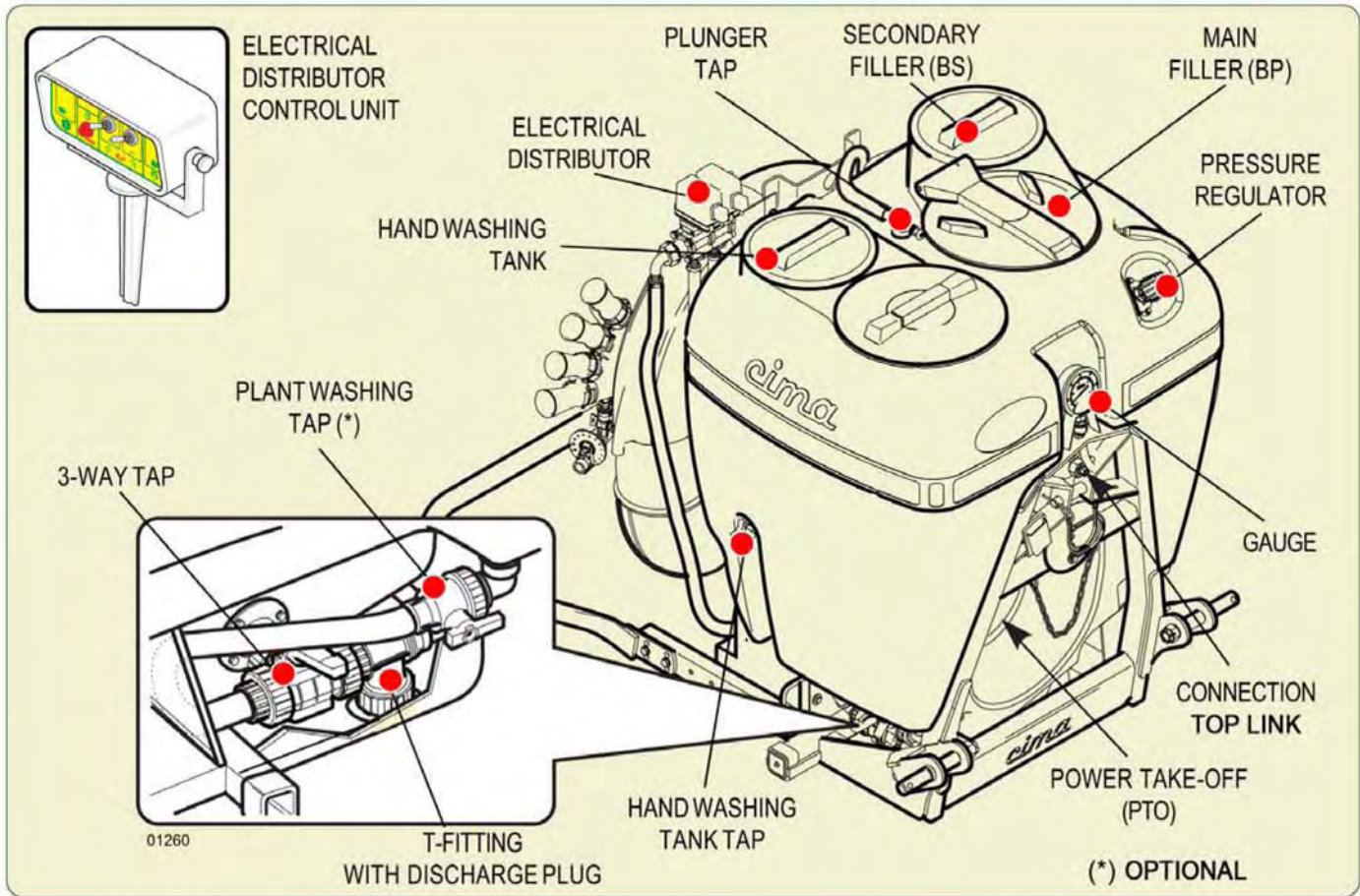

4.1 - FRAME

The frame of the New Plus sprayers represents the framework of the machine. The accommodation and the fixing for the gearbox – fan casing group, the tank, the pump and the liquid circuit

A rear bumper is provided to protect the sprayhead. This must be mounted in the most effective position, according to the operating conditions and in keeping with the type of heads utilised.

A chain with hooks, fixed to the front part of the frame, allows the support of the transmission joint when the machine is coupled to the tractor. All frames are pre-set with axles for the application, of a pair of wheels on request (see Paragraph 7.2).

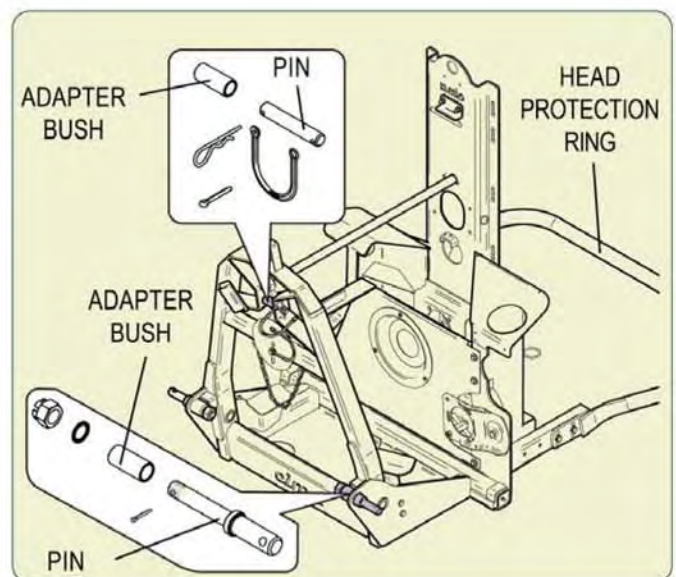

4.2 - OVERRUNNING CLUTCH

A **overrunning clutch** is included between the Power Take-off and the fan control pulley. In case of sudden decelerations or unexpected engine stoppage, this allows the fan to continue its free rotation, thus avoiding extreme mechanical stresses to be transmitted to the drive members.

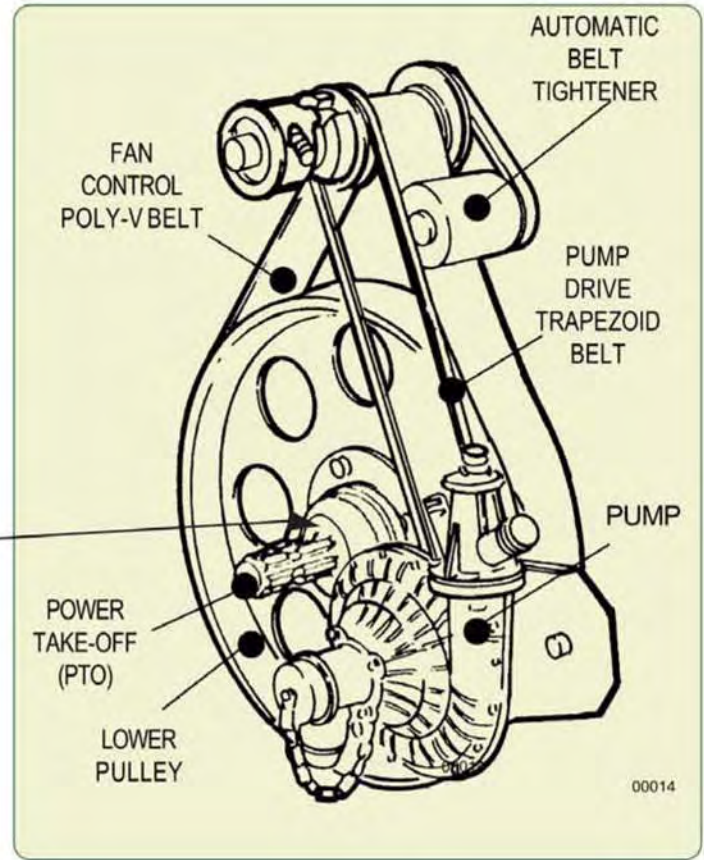
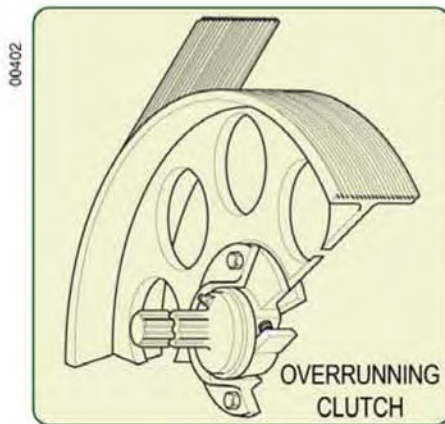

Centrifugal fan

The fan casing can rotate 360 degrees. This permits the positioning of the outlet spout at the point necessary for the assembling of the different distribution devices.

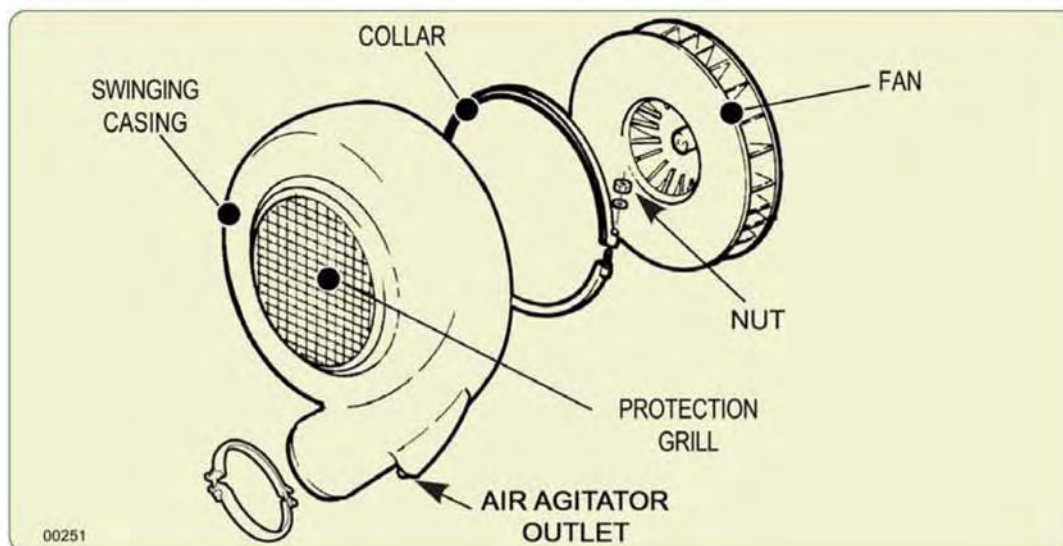

4.3 - LIQUID CIRCUIT

4.3.1 – Operating principle

WORK – The tank (P1) contains the mixture that need to be sprayed on the **crops** to treat. The tank (P1) is connected with the pump (P4) by the 3-way tap (P2). When the tap (P2) is in position “A” - **WORK**, the mixture is sucked by the pump (P4) and sent to the pressure regulator (P5) and to the distribution device (sprayhead) through the 3-way tap (P6).

The regulator (P5), together with the correct position of the rotating disc regulator, allows to modify the spraying pressure of the sprayer so to can reach the correct **gallons per acre** needed. The exceeded quantity of the liquid supplied by the pump through appropriate pipes is directed inside the tank in order to maintain as constant the mixing agitation.

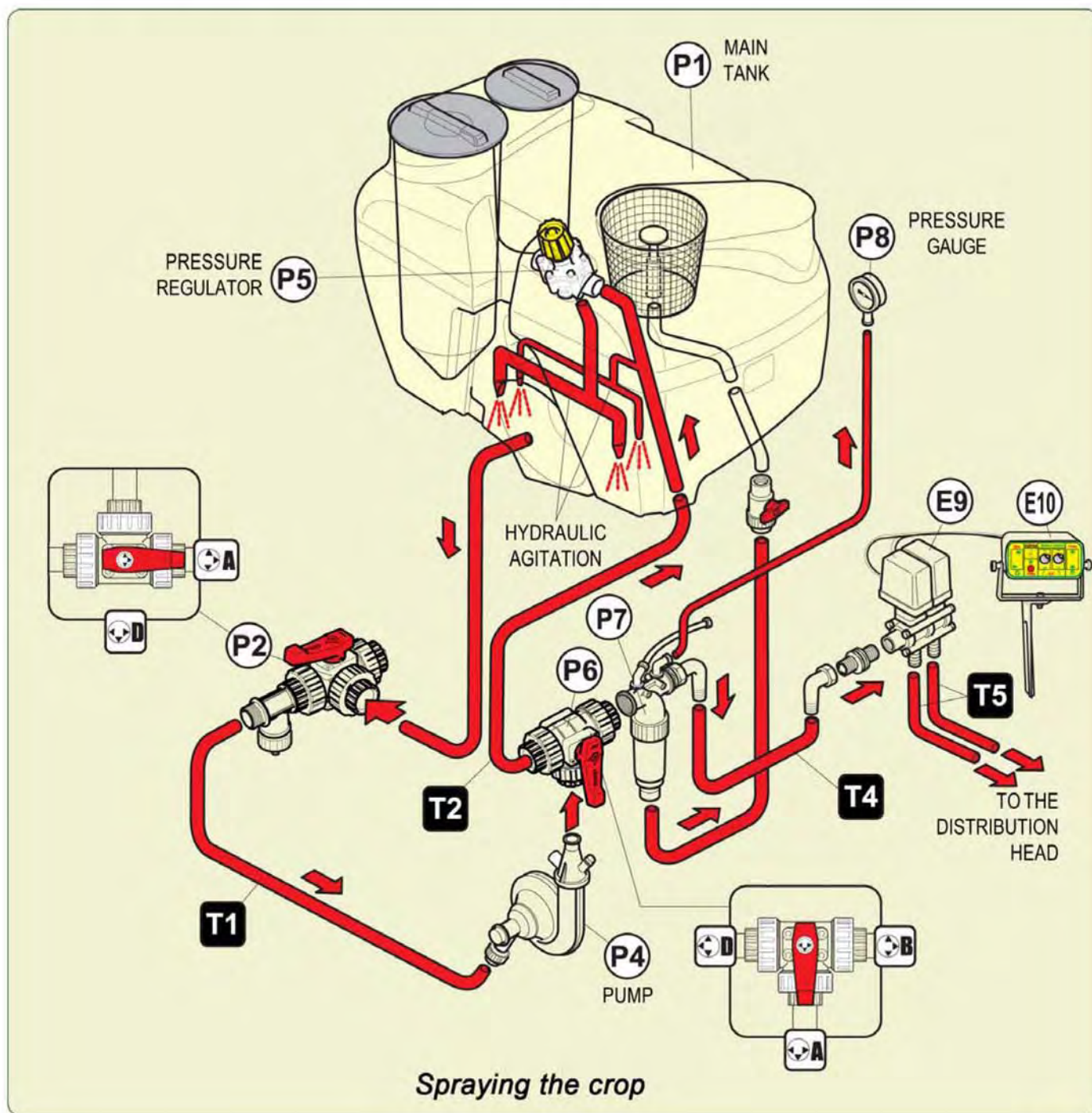

MIXING: The valve P12 needs to be in position “A” when mixing powders. All other times the valve should be in position “C”. The other two valves should be in the position shown.

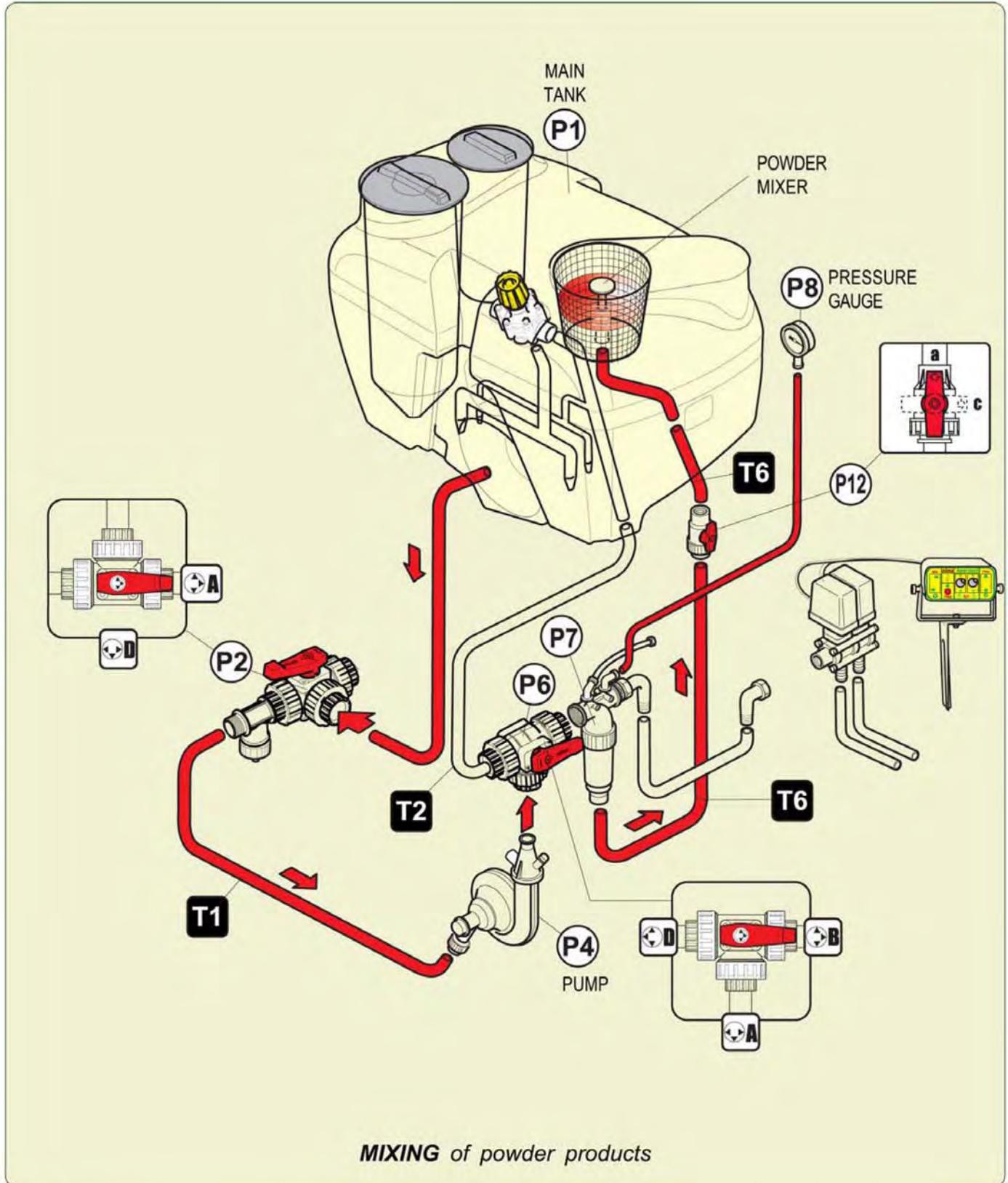

P1. TANK

Polyethylene tanks are available in 75, 100, and 150 gallon capacities.

Each tank is made up of:

- tank main filler, with a hinged cover and strainer basket. (BP)
- supplementary tank filler with screw-type lid, for filling with clean water. (includes strainer basket (BS))
- transparent level indicator external hose with graduated scale
- liquid agitation system connected pressure regulator (P5) and to the pump (P4)
- jet agitation system connected to piston on/off valve and connected through air hose to fan housing.

A = OPEN
C = CLOSED

P22. HAND WASHING TANK

Incorporated polyethylene 17 litre capacity hand wash tank, with external service tap; opening through a 255 mm diameter screw lid.

P2 - 3-WAY LEVER TAP A WITH DISCHARGE FITTING

Fixed to tank (P1) and connected to the suction piping (T1).

The different positions of tap (P2), displayed on the decal placed on the machine, are as follow:

A - WORKING

(phytosanitary products distribution).

D - CLEANING CIRCUIT

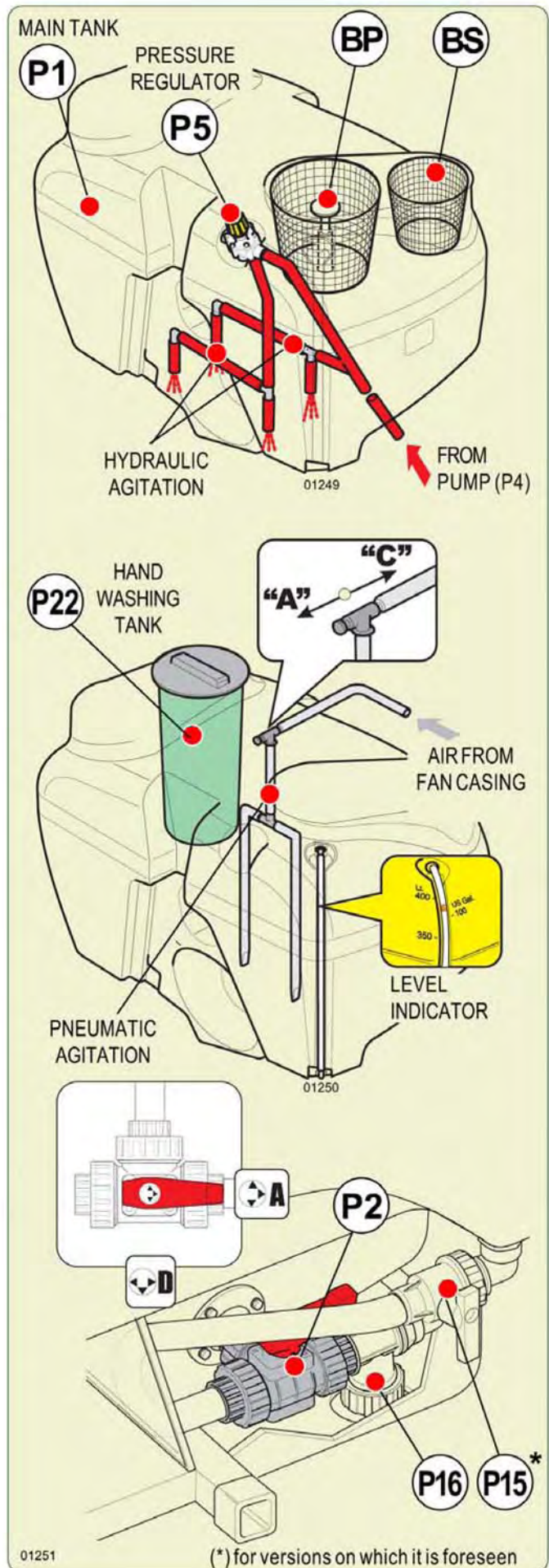

P4 - CENTRIFUGAL PUMP

Fixed to the left-hand side of the machine, it is connected to the tank through the pipeline (T1), to the three-way faucet (P6) and to the **liquid** agitation system for the mixture. The pump is provided by the suction side of a filter to prevent the accidental entry of foreign bodies in the pump body, such a possibility does not constitute a hazard and can only cause damage to the impeller shown by a drop in pressure reported by gauge.



THE PUMP MUST NEVER RUN DRY

P6 - 3-WAY VALVE

It is mounted on the centrifugal pump (P4) and is connected to the body of the filter (P7). The different positions of tap (P6), displayed on the decal placed on the machine, are as follow:

A - SPRAYING

B - MIXING POWDER

D - FILTER MAINTENANCE

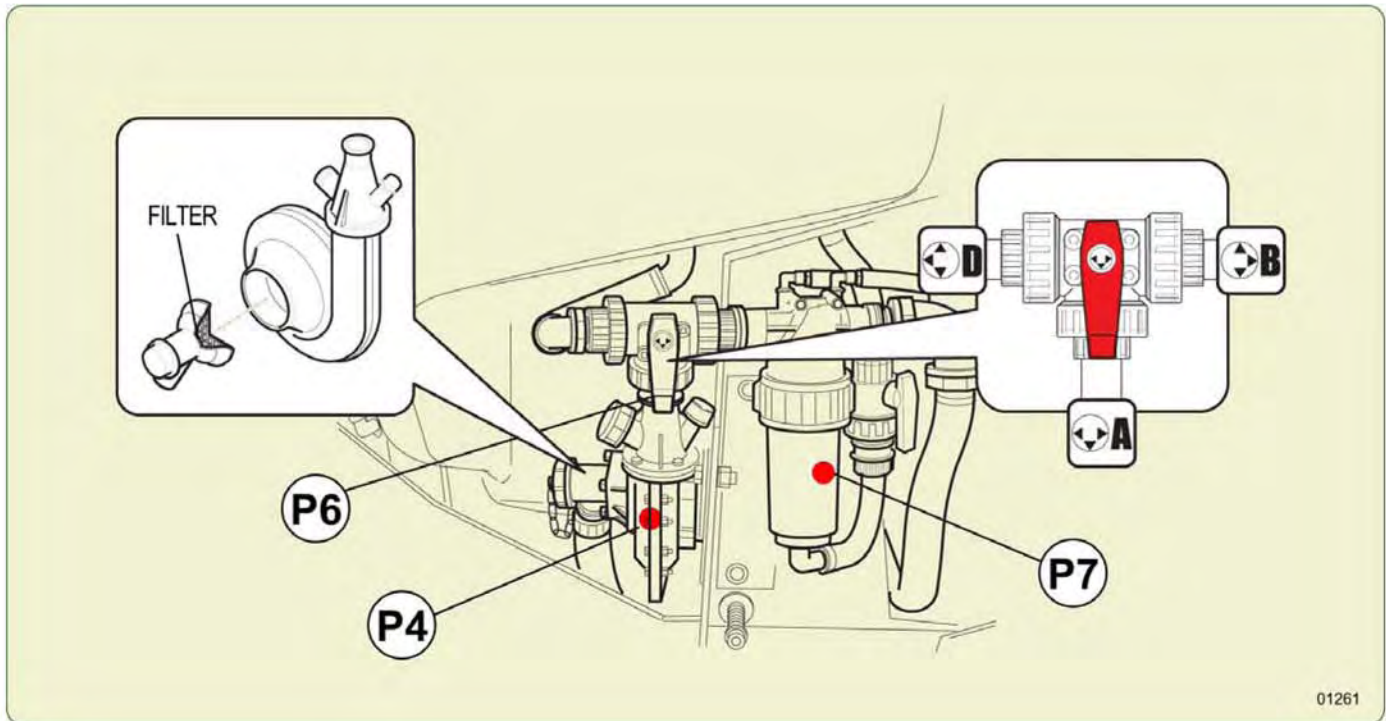

P7. FILTER

The filter has a filtering capacity of **65 gallons per minute** with a 50 mesh cartridge. The dirty cartridge causes the operating pressure **drop**. This is signalled by the pressure gauge.

P8. GAUGE

Glycerine-filled, with dial from 0 to 80 PSI (6 bars)



Set the working pressure keeping the E9 (or P9) distributors opened.



E10. CONTROL UNIT - P55 Only

It is electrically connected to the distributor with 2 motorised solenoid valves (E9) and to the main socket of the tractor (Lighter tap).

The 2 lever switches, controlling the solenoid valves (E9), have to be set to "ON" for opening and to "OFF" for closing. The control unit is equipped with a bayonet support to be inserted in the bracket provided. This must be mounted on the tractor, within the driver's reach. When the machine isn't hitched to the tractor, it must be placed in the position on the forward part of the machine frame.



E9. ELECTRICAL DISTRIBUTOR WITH TWO SOLENOID VALVES

It is connected with the feeding pipe (T4), the distribution pipes (T5) and the electrical unit (E10), which is fastened on the tractor. The solenoid valves open and close themselves, according with the action carried out on the electrical control unit switches.

Standard on P55 sprayer only.

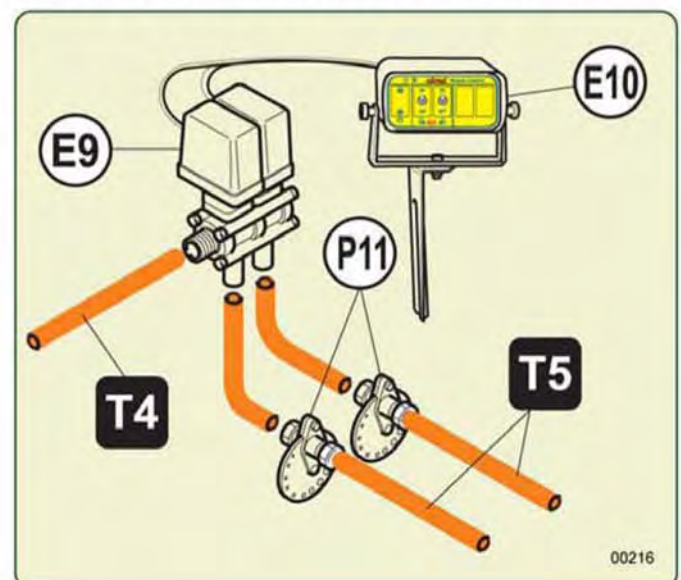

P12. POWDER MIXER LEVER VALVE

Positioned on the pipe (T6), between the filter (P7) and the mixer (P13) in correspondence with the inlet of the pipe into the main tank (P1).

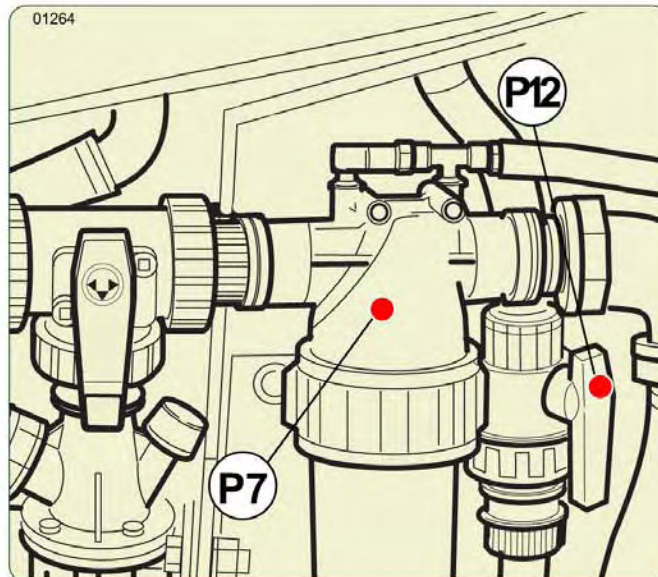

P13. POWDER MIXER

It makes the mixing of the powdery products during the filling of the tank. It is mounted on the basket filter of the main filler (BP) and it is connected to the pump (P4) by the pipe (T6). Thanks to that system, the powder products contained inside the basket get more gradually dissolved, and the building of crumbs and thickenings can be avoided.

The shower head can be replaced by a containers washing device

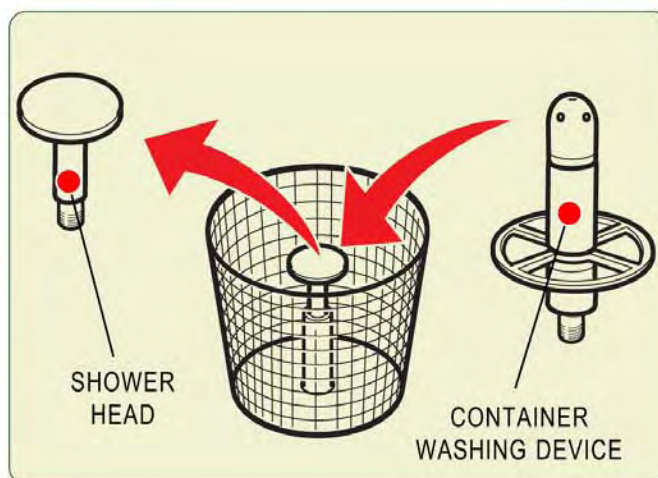

For the container washing procedure operate as for the washing of the circuit (see par. 10.4) with the tap (P6) in pos. "B" and the tap (P12) open.

E9. ELECTRICAL DISTRIBUTOR WITH TWO SOLENOID VALVES

Standard on P55 model only

It is connected with the feeding pipe (T4), the distribution pipes (T5) and the electrical unit (E10), which is fastened on the tractor. The solenoid valves open and close themselves, according with the action carried out on the electrical control unit switches.

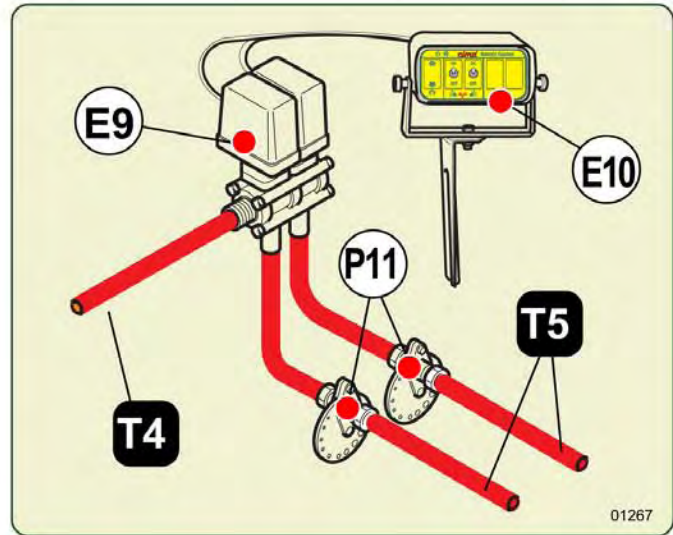

P9. MANUAL DISTRIBUTOR WITH 2 LEVER-OPERATED VALVES

It connects the feeding pipe (T4) to the distribution piping (T5). It remote-controls the closing and opening of the pulverising. The mount bracket, supplied with the machine, must be secured to the tractor within the driver's reach. When the machine is not hitched to the tractor, it must be placed on the forward part of the sprayer's frame.

Each **valve** permits the spraying from a single side of the head: to the right and to the left respectively. They are **open** when the levers are set in the **vertical** position.

They are **closed** when the levers are **horizontal**.

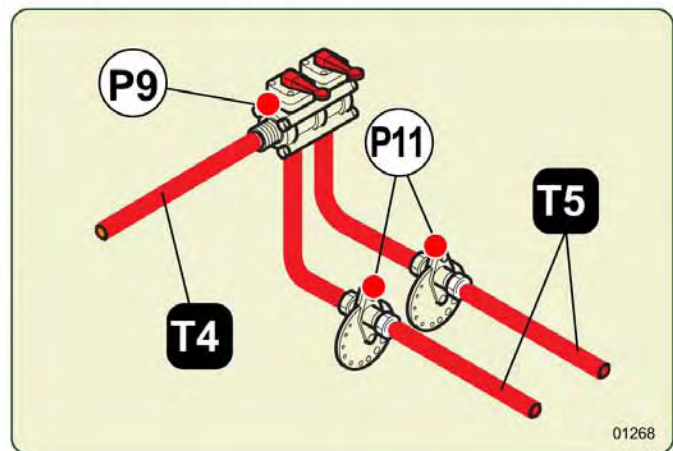

P11. CALIBRATION DISC (Patent N° 23238)

It selects the flow rates necessary to the treatment and is mounted on the distribution devices. It is made up of 2 flanges, held in position by two butterfly nuts, locking a disc with calibrated holes numbered from 1 to 15. A groove on the edge of the disc allows the exact positioning of the hole to be utilised. Its number must appear in the flange's semi-circular seat. The rotation of the disc is obtained by loosening the butterfly nuts by a few turns. After the operation is done, screw back carefully.



Any faulty sealing condition of the liquid circuit causes an intermittent issuing of the sprayed material. It is necessary to carefully check the efficiency of the sealers and clamps, the tightening of the ring nuts and fittings and the good working condition of the piping.

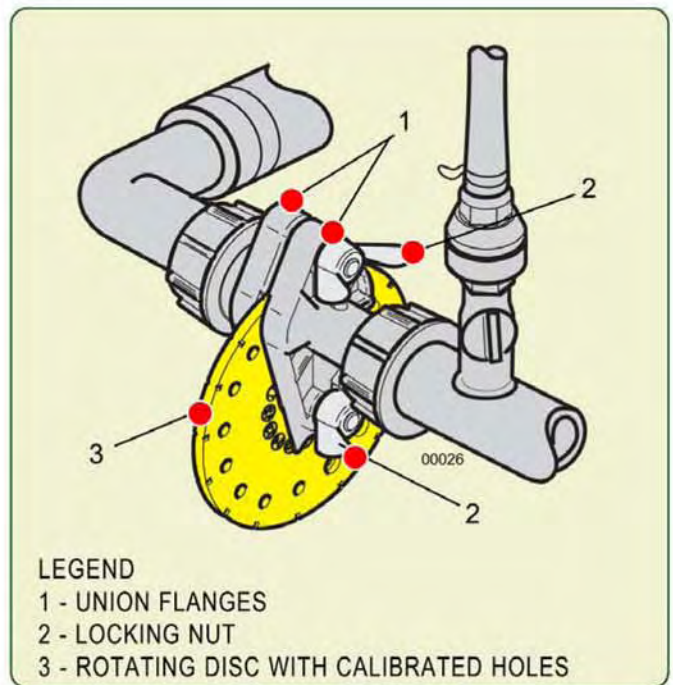

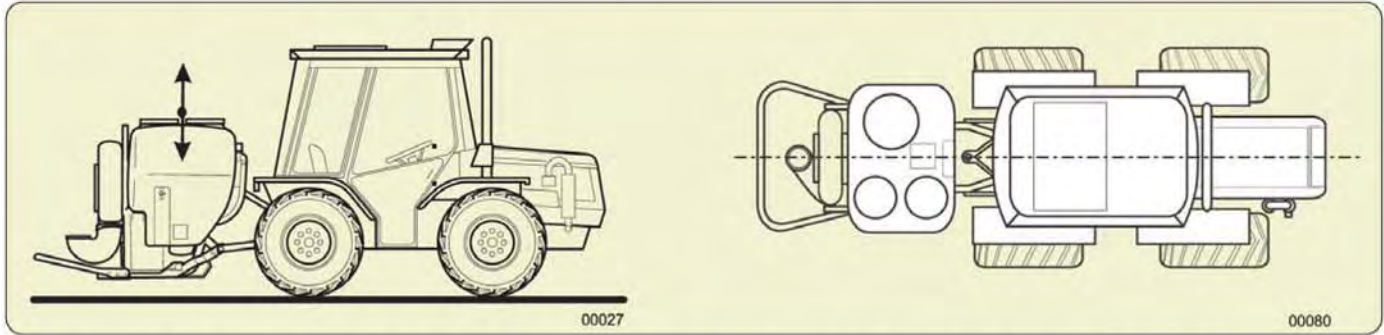

5.1 - MOUNTING OF CARDAN TRANSMISSION SHAFT



The mounting, disassembling or possible other interventions on the transmission shaft must be carried out with the engine switched off and with the starter key removed from the tractor's control panel.



USE TRANSMISSION SHAFTS WITH CE CERTIFICATION. OBSERVE THE REGULATIONS CONTAINED IN THE USE AND MAINTENANCE BOOK



The cardan transmission shaft must work with the 2 COAXIAL drive outlets (PTO) or, should this not be possible, with the PARALLEL axles. In this case the angle of the joint **MUST NOT EXCEED 15°**.

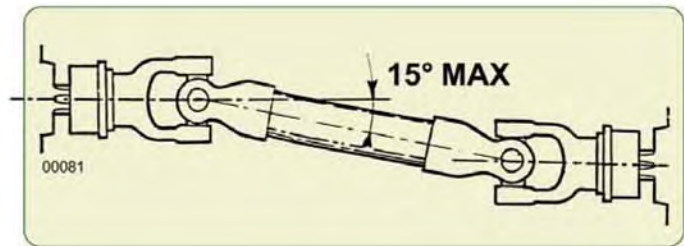

Definition of the length

Set the 2 drive outlets (PTO) perfectly on the same axis and measure the distance "D" between their grooves. Length "L" of the cardan transmission shaft (refer to the picture) to be deployed, measured between the 2 stopping pawls and with joint closed, must be 1.5" - 2" lesser than distance "D".

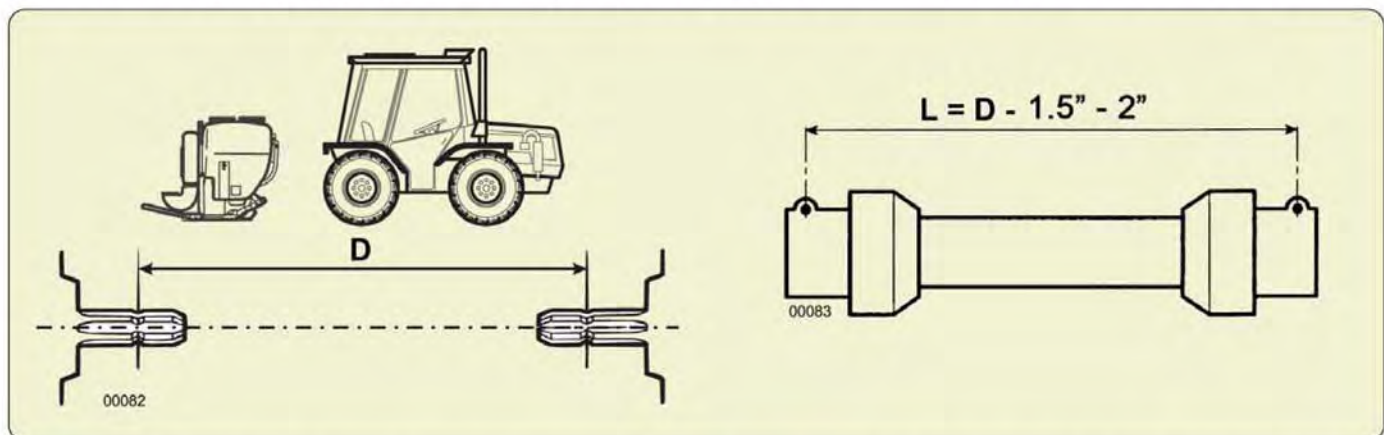

Using the cardan shaft too much short can cause the breach of it, with serious damages to the sprayer and/or to the tractor, and dangerous for the persons.



Using the cardan shaft too much long cause a push on the two PTO, that it can cause huge mechanical damages both to the tractor and to the sprayer.

6.1 - POSITIONING OF FAN CASING HOUSING

The fan's air outlet must be positioned according to the distribution head to be mounted and the position in which it is to be utilized. The operation is possible since the fan's casing can be rotated on its axis up to 360°.

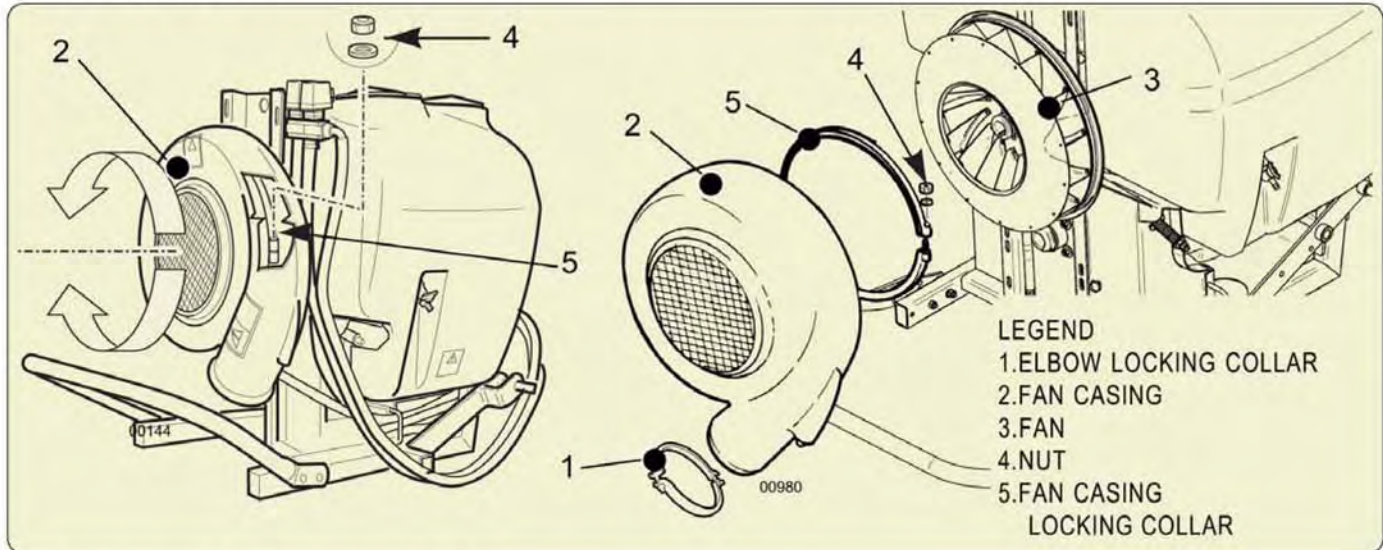

POSITIONING OF THE HOUSING:

1. Position the sprayer on the ground if it is mounted on the tractor.



Switch off the tractor and remove the key from the control panel.

2. By undoing the locking nut, loosen the collar which supports and locks the casing to the frame, located opposite the suction grill.
3. Rotate the casing and place the outlet in the position necessary for assembling (indications contained in the use and maintenance booklet of the distribution device).
4. After this has been done fasten the collar again.

6.2 - ELBOW FITTINGS OF DISTRIBUTION HEAD

The elbow fittings support and connect the distribution devices to the fan casing. Several types are assembled on available standard machines, while others, must be supplied together with the distribution device.

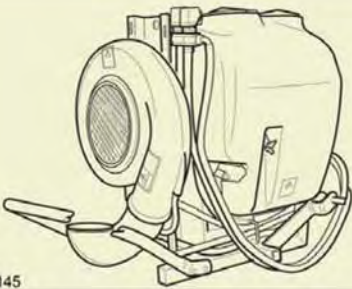
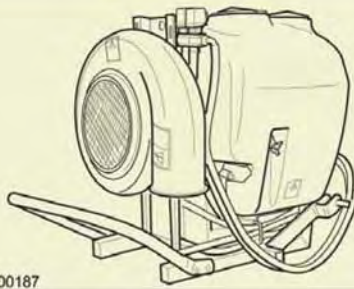
NEW PLUS SERIES	42 - 45 - 50	55 - 55S - 55E
STANDARD BASIC MODELS		
SPRAYER PROVIDED	WITH 180° ELBOW	WITHOUT ELBOW

7.1 - PAIR OF WHEELS (Optional)

The wheels thread can be adapted to that of the tractor.



MOUNT THE WHEELS AFTER HAVING HITCHED THE MACHINE TO THE THREE-POINT LINKAGE.

DISMANTLE THE WHEELS BEFORE UNHITCHING THE MACHINE FROM THE THREE-POINT LINKAGE.

EXECUTION:

1. Hitch the machine to the tractor and lift it to a height at which the wheels can be mounted.

2.



Stop the tractor, remove the key from the control panel and ensure that no one operates the three-point linkage's hydraulic controls. AVOID OPERATING AND STANDING BENEATH THE MACHINE OR WITHIN THE AREA THAT MIGHT BE INVOLVED IN ITS SUDDEN LOWERING.

3. Insert the wheels' axle shafts into the machine's axle.
4. Adapt the wheels' track to that of the tractor.
5. Lock the axle shafts by means of the axle screws.
6. Start the tractor and keep the sprayer lifted during the transfers, lowering it to carry out the treatment.



THE SPRAYER MUST BE LIFTED AT EVERY DIRECTION CHANGE MAKING SURE THAT THE WHEELS ARE NOT RESTING ON THE GROUND.



The operating pressure of the tires is indicated on the decal placed on the rim of each wheel.

7.2 - SWIVELLING DEVICE

It is an accessory used to modify the direction of the spraying during the use of the sprayer; it can be used only with the distribution devices with delivery on the one side.

There is two type of swivelling device: manual controlled or electrical with remote control panel.



All indications and instructions are provided in the "Distribution heads - Operation and maintenance instruction" booklet of the distribution devices with which it can be used.

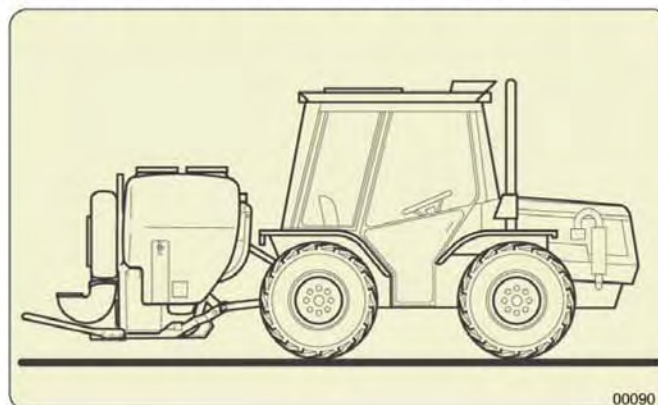

00090

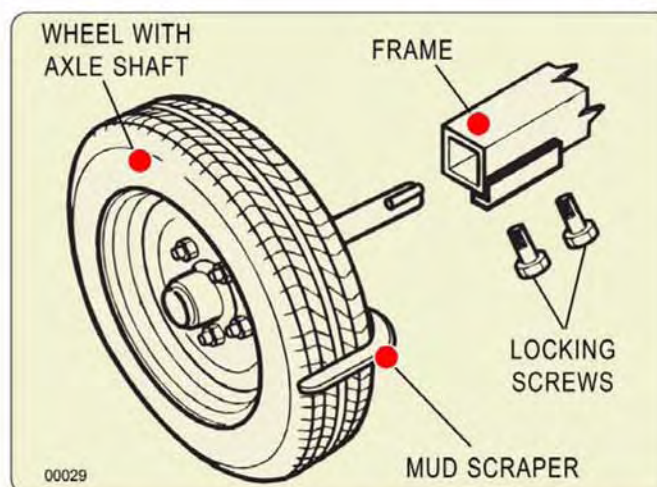

00029

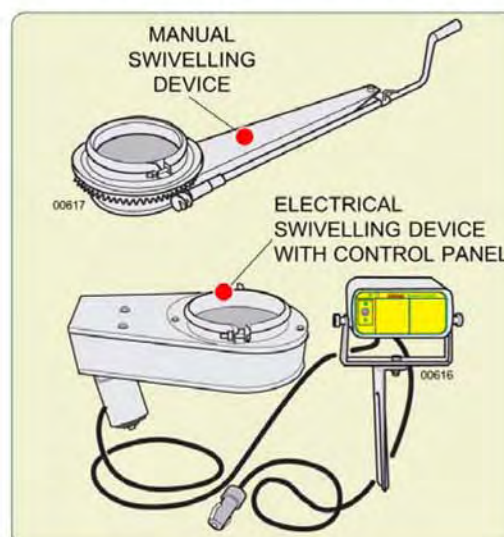

The **hydraulic** and the **air** circuits mounted inside the tank, allow to realize a **double agitation system**: with the pump water and with the fan air, **at the same time**. The **air** circuit can be excluded, when the products used have a quite strong foaming effect, by closing the **air agitator valve**. When that **valve** is opened again, check that some **air outlet holes** aren't obstructed.



It is advised however to also use always the **pneumatic agitator**, adding to the mixture, if necessary, a **antifoam product**.

This operation is of main importance, in order to get a uniform distribution of the active principle on the whole vegetative surface to be treated. Should the activity need to be interrupted during a treatment with the sprayer, **keep the agitator activated until the treatment is resumed**.



Before starting the treatment, or return to work after a break, it is essential to agitate the mixture in the tank, re-circulating it completely for as long as it takes to make it homogeneous.



The agitation can be carried out with the **manual pressure regulator (P5)** or **electric (E5)**, in any position.

The **tap of the pneumatic regulator** has to be open.

THE MIXTURE AGITATION HAS TO BE CARRIED OUT WITH THE POWER TAKEOFF RUNNING AT A RATE OF AT LEAST 500 RPM..

9.1 - PREPARATORY OPERATIONS TO TREATMENT



THE FILLING MUST BE CARRIED OUT WITH THE MACHINE ON A FLAT SURFACE. BEFORE THE OPERATION, IN THE ALLOCATED AREA, THE DOSES OR MIXTURES TO BE POURED IN THE TANK MUST BE MADE READY.

Before starting the filling cycle, check:

- FAN SHAFT SUPPORT OIL LEVEL.
- THAT THE CARTRIDGE AND THE DELIVERY FILTER (P7) ARE CLEAN; (Sec. 12.4)
- THE EFFICIENCY OF THE DISTRIBUTION DEVICE (HEAD);
- THE CONDITIONS OF THE TANK LEVEL INDICATOR.

- **The operator must:**

- a. Wear adequate protective clothing and accessories such as overalls, waterproof suits, gloves, glasses and masks to shield him from contamination by inhalation or contact with the products handled.



- **Anti-dust masks don't offer any protection against toxic vapours.**
- **Avoid wearing loose clothes that might entangle with moving parts.**

- b. With the parameters defined during the preliminary operations, carry out the adjustments of the sprayer.
- c. Prepare the mixtures in a well ventilated area. When in the open, the presence of wind increases the danger of contamination.
- d. Precisely weigh the previously calculated doses of products to be mixed at every filling operation.
- e. Avoid handling products close to open flames, embers, incandescent bodies or in the presence of flammable substances.
- f. In order to obtain the correct volume dosage of agro-chemicals and fertiliser mixtures, the fertiliser must be first diluted.
- g. Wash and rinse the just emptied product containers with clean water – collect the washing water and pour it in the tank before carrying out the filling – place the empty packaging in the specific container or in the collection area.
- h. Wash the equipment and tools utilised in the preparation and place them in the chemical products storage area.
- i. **Always** leave the area assigned to the loading and preparation of the mixtures in such condition as to avoid **any** possibility of contamination to persons or animals or of pollution to the environment.



- **AT THE END OF THE OPERATIONS NECESSARY FOR CARRYING OUT THE INTERVENTION, THE LOCATION-STORAGE AREAS MUST BE LEFT IN THE CONDITION REQUIRED FOR THE CARRYING OUT OF THEIR PREVENTION AND PROTECTION FUNCTIONS.**
- **BEFORE STARTING THE TRACTOR, KEEP AWAY PERSONS OR ANIMALS AND NEVER LEAVE IT UNATTENDED DURING THE PREPARATION OPERATION.**

9.2 - THE TREATMENT



IT IS ADVISABLE TO BEGIN TREATMENT AT THE HEADLANDS.



WHEN THE TREATMENT IS OVER, OR IF THE SAME HAS TO BE TEMPORARILY INTERRUPTED, ALWAYS LET THE FAN STILL OPERATE FOR APPROXIMATELY 30 SECONDS AFTER CUTTING-OUT THE POWER SUPPLY (EITHER MANUAL DISTRIBUTOR P10 OR ELECTRICAL DISTRIBUTOR E11), IN ORDER TO FULLY ELIMINATE THE PRODUCT MIXTURE FROM THE DISTRIBUTING DEVICES, SO PREVENTING ANY POSSIBLE ANOMALOUS DRIPPING FROM TAKING PLACE.

- **The operator must:**
 - a. Shake the mixture in the tank before starting the treatment, re-circulating it completely for as long as it takes to make it homogeneous.
 - b. Check **the orientation of the distributors (hands, guns and/or fishtails) of the distribution device (sprayhead) in relation to the dimensions, the shape and the thickness of the vegetation to be treated.**
 - c. Continue to shake the mixture until the treatment is resumed should the intervention momentarily be interrupted. If the utilisation is to be deferred, check that the filter cartridge is clean before resuming and **agitate the mixture** that has remained in the tank.
 - d. Ensure that the hand wash supplementary tank is filled with clean water after each filling operation.
 - e. Make use of individual protections identical to those envisaged for the preparation of mixtures if the tractor is not equipped with a pressurised cabin with aeration filters.
 - f. wash immediately all the elements that might have become contaminated during the treatment, promptly remove the polluted garments and **interrupt the work if these cannot be immediately replaced.**
 - g. Keep to the preliminary operations already indicated (10.1.c), in case of wind conditions prevailing.
 - h. Stop the engine, remove the key from the tractor's control panel and lower the hoist during stoppages.
 - i. Pay particular attention to the treatment when close to boundaries and in proximity of dwellings, waterways, roads or public-usage paths.

9.3 - END OF TREATMENT - STORAGE

if the machine HAS NOT a spray-line rinsing tank:

- a. Put about 5 gal. of clean water in the tank and spraying it in the already treated area.
- b. Wash the tank:
 1. Wash the main tank internally with a water jet employing a quantity of clean water equal to almost 10% of tank capacity, with the agitator while running
 - 2a. Discharge the rinsing water in a proper area provided with a drain basin for the collection and take care of waste according to the country rules.

Or

- 2b. Spraying the rinsing water in the already treated area. Then, discharge the remaining water of the tank and pipes (about 5,6lt) gathering it in a proper container to waste it following the rules or use it again, putting it again in the tank, for a next treatment, if this will be suitable with the product to use.

If necessary repeat the washing procedure.

- c. Wash the machine externally:



To wash it externally DO NOT USE high pressure washer (MAX 5 bar).

When each treatment has finished, it must wash the sprayer outside, in a proper area provided with a drain basin for collection and subsequently treatment of rinsing water.

These area are forbidden to unauthorized personnel, children and pets.

To outside sprayer rinsing, it is possible to use proper cleaning products and biodegradable to make the operation easier.

When the rinsing is finished, switch on the fan for few second (about 10) to remove residual water on carter and pipes which lead the flow to the sprayhead.



The use of detergent products for the cleaning operations is allowed only in the observance of the regulations in force. For these, the operator must gather the relevant information from the specifically appointed bodies ruling on this subject.

- d. Check the efficiency of the distribution device (head) and the cleaning of the pulverising points (diffusers), possibly replacing them if found to be damaged.
- e. Clean out the filter cartridge.
- f. Keep the machine on a plane surface with a suitable consistency, in a ventilated place, sheltered from rain or sun: sunrays are the worst enemies of plastic and rubber parts.

10.1 - CLEANING & STORAGE

- **The operator must:**
 1. Wash and flush out sprayer after completion of each phase of your spraying program.
 2. Flush out sprayer when changing chemicals if there is a possibility of incompatibility.
 3. Clean sprayer very thoroughly before storing at the end of the spraying season. If you are in a cold climate, final rinse should be with a sufficiently concentrated anti-freeze to prevent freeze up in areas that were not thoroughly drained.
 4. Check sprayer over for needed repairs before time to spray again.
 5. Preparing the sprayer for use in the Spring means completion of all needed repairs, installation of all drain plugs and checking spraying for leaks with a tank of water.



THE PUMP MUST NEVER RUN DRY.

Completely drain the liquid circuit, paying special attention to the centrifugal pump; in order to completely drain the pump, remove the draining plug, which is mounted on the pump itself.

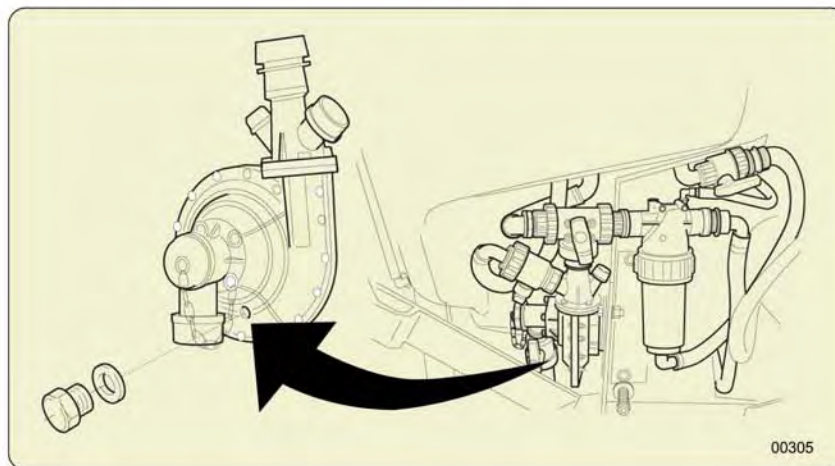

Avoid using anti-freeze solutions.



The machine must be stored in a secure or closed place, so as to prevent access to unauthorized personnel.

• Lifting and transport of the sprayer



Before carrying out any operation it is essential to verify that no chemical mixture are left in the tank.

1. Check that the cables or chains used for the lifting are adequate for the weight to be lifted (machine – distribution devices - accessories).
2. Hook the machine through the specific support point indicated by the specific decal on the frame, checking all the parts involved in the operation.
3. Lift the machine, verifying that it is properly balanced, and, on those units equipped with either cables or hoisting chains.

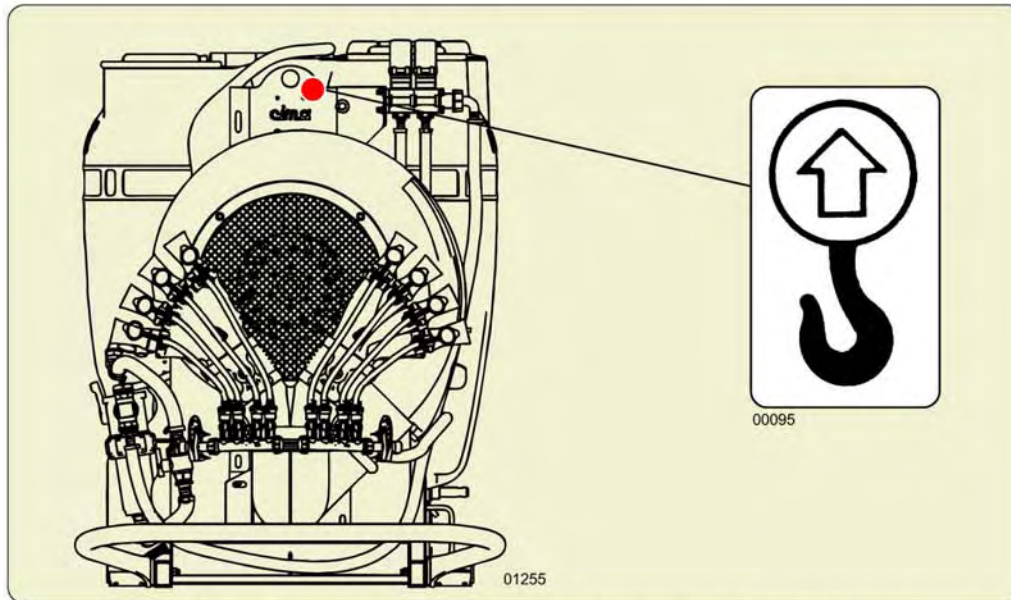

4. Position the sprayer on the transporting vehicle in perfectly stable conditions.
5. During transport the machine must be fastened to the carrier by way of suitable strapping.



ALL OPERATIONS MUST BE CARRIED OUT WITH THE ENGINE SWITCHED OFF AND WITH THE IGNITION KEY REMOVED FROM THE CONTROL PANEL.

12.1 - LUBRICATION

Maintenance point (all models)	Action	Consumption material	Periodicity
Fan shaft support	Check oil level	Oil SAE 90	8 hours
Fan belt-tensioner support	Greasing	Grease Type EP Classe NLGI 2	200 hours
Overrunning Clutch	Greasing	Grease Type EP Classe NLGI 2	200 hours
Fan shaft support	Change oil	Oil SAE 90	Annuary

PLUS_003



Carefully clean the greasing nipples and the oil filler in order to avoid that, during lubrication, dirt might be introduced. In the case of intensive use of the machine, reduce the lubrication intervals.

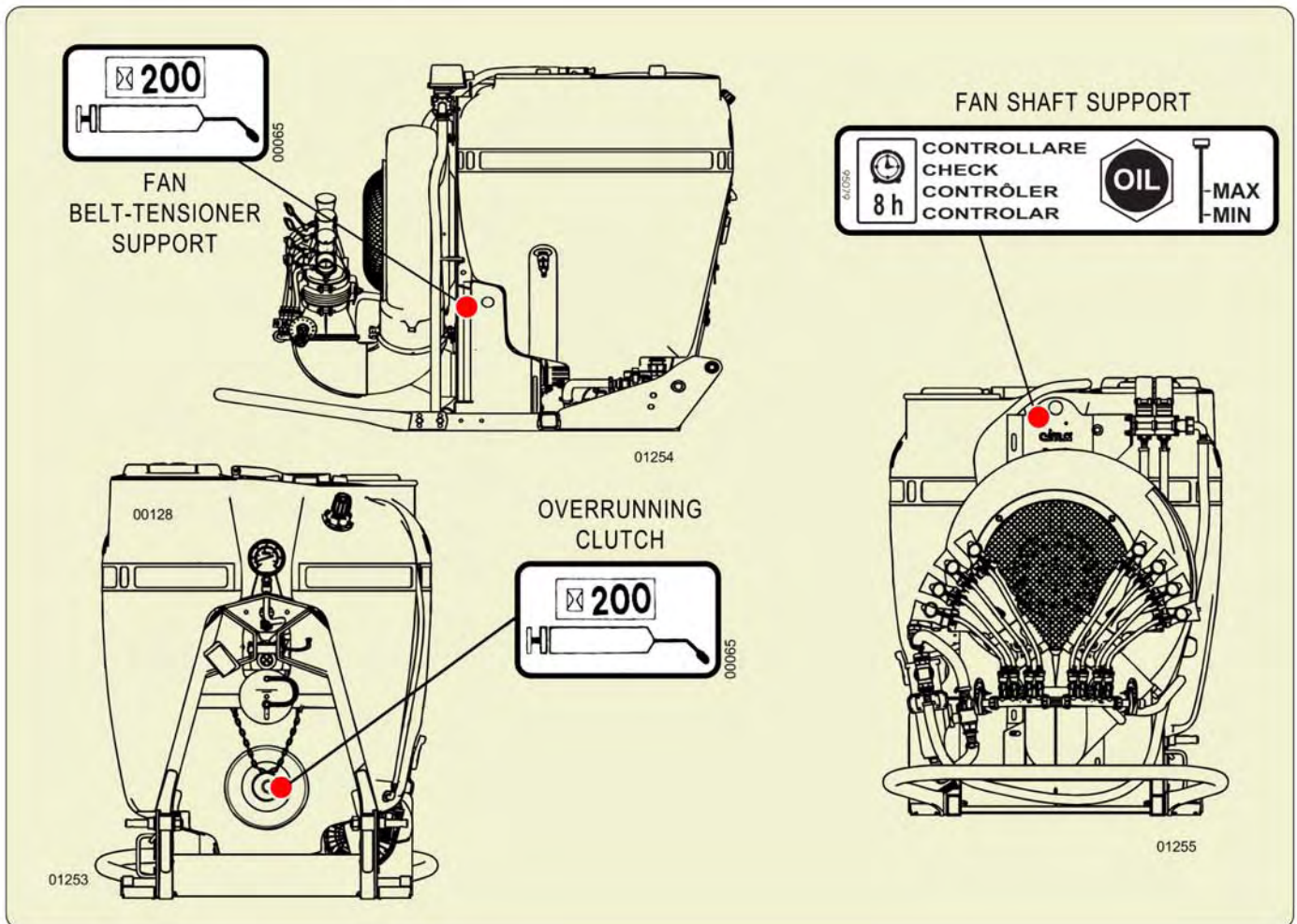

12.2 - FAN SHAFT SUPPORT OIL LEVEL CHECK

1. Unscrew and remove the oil filling plug with the dipstick.
2. Clean the dipstick and introduce it again.
3. Extract the dipstick and check the oil level, which has to be between the two minimum and maximum level notches of the dipstick itself.
Should it be necessary to top up the level, add some SAE 90 oil, up to reach the dipstick upper notch (MAX).
4. Introduce and screw the oil filling plug with the dipstick.

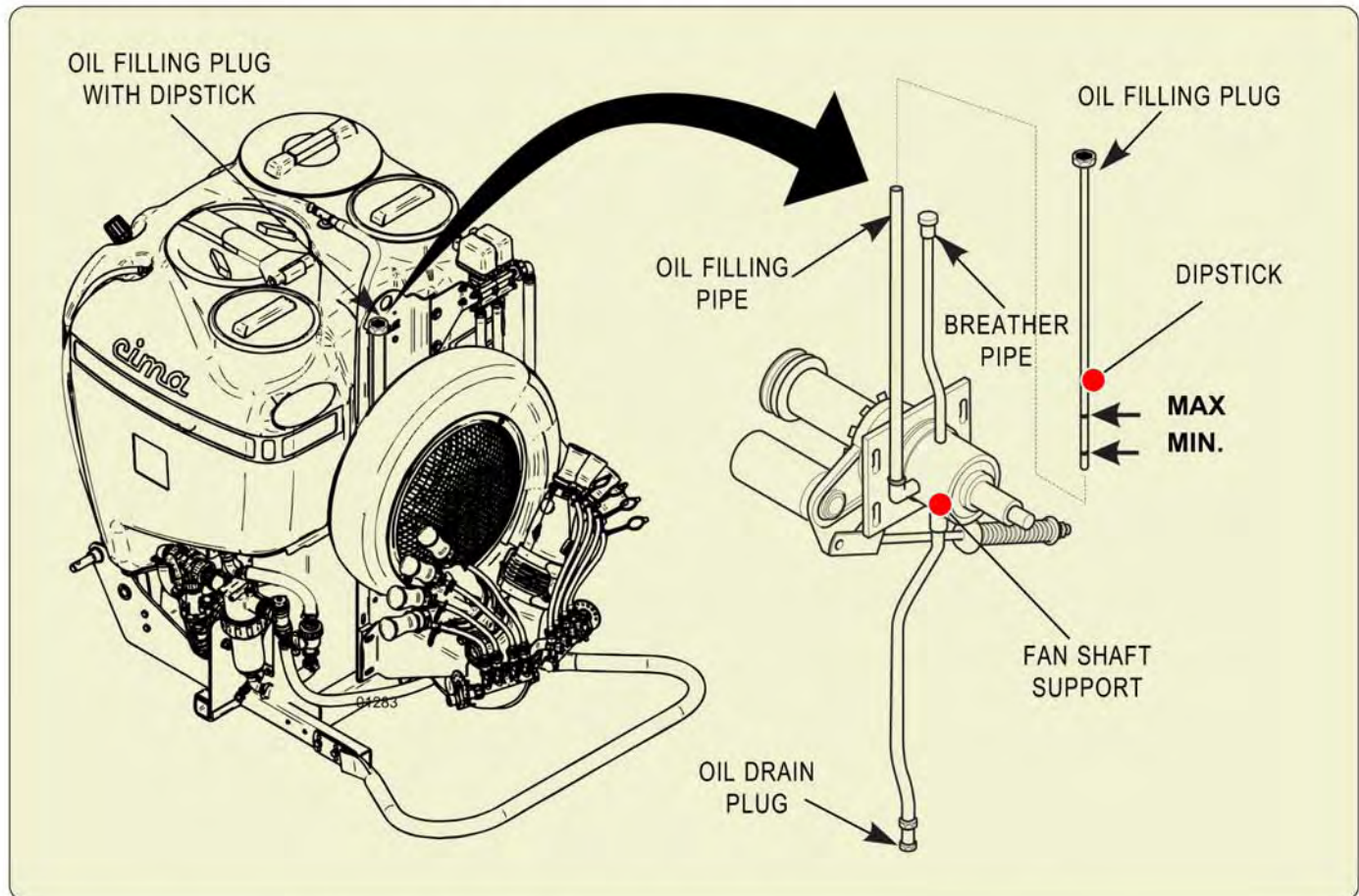

12.3 - FAN SHAFT SUPPORT OIL REPLACEMENT

1. Unscrew and remove the oil filling plug with the dipstick.
2. Remove the oil drain plug and let the oil completely flow out from the fan shaft support.
3. Check the oil drain plug and the relevant seal for integrity, replace them, if necessary, and close again the oil drain plug.
4. Through the filling pipe, pour a SAE 90 oil proper quantity, up to reach the MAX notch on the dipstick:
- taking very little oil to fill, fill slowly and check level often.
5. Position again the plug with the dipstick and close the oil filling pipe.

12.4 - CLEANING OF FILTER'S CARTRIDGE

1. Set the lever of 3-way valve (P6) to the "d" position
2. Verify that the faucet (P12) of the powders mixer is closed
3. Close the manual distributor's valves (P9) or position the switches of the control electric switchboard (E10) on "OFF"
4. Undo the thumb screw and remove the body of the filter.
5. Extract the cartridge: clean the grill and the retaining O.Ring.
6. Reassemble the cartridge and secure the lid with the thumb screw. **Pay attention to the O-Ring of the lower body during the assembly:** the incorrect sealing of the filter will jeopardise the proper operation of the sprayer and cause loss of the mixture.

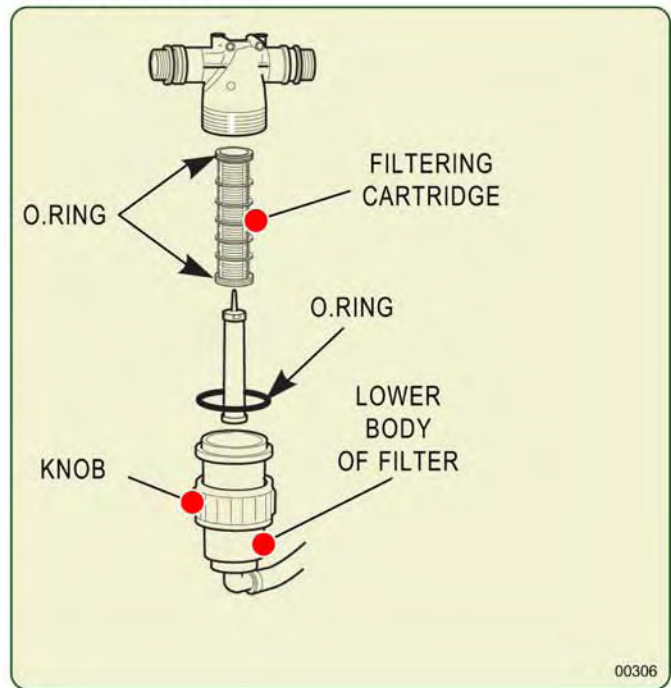

12.5 - PURGING OF RESIDUES FROM FILTER

With the machine in operation and the valves of the manual (P9) or electrical (E9) distributor closed. Opening the powder mixer tap (P12) the delivery flow will drag possible sludge to the bottom of the filter within the tank through the piping (T6) thus partially cleaning the filtering cartridge. Close the valve when the operation is completed.



When the machine is in operation, check that the drain tap (P12) is closed before opening the main feeder.

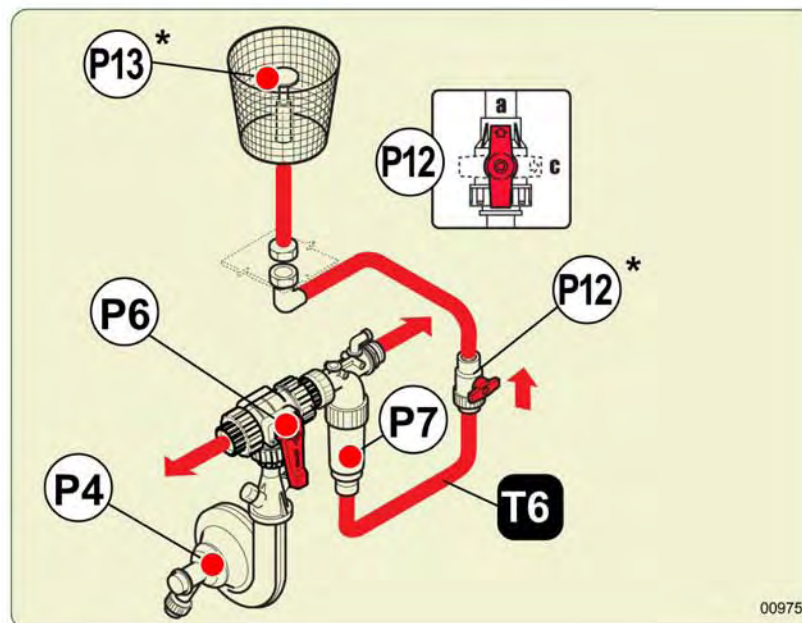

12.6 - FAN BELT TENSIONER

Check length "L" of the spring (refer to Picture): it should be in tension between 3 1/2" to 4 5/8".



If the fan control belt has to be replaced, the correct tensioning of the same one (spring length) must be checked after the first and after the second operation hour. If the value measured exceeds 4 5/8", tighten the belt tightener screw, up to get the minimum length (3 1/2").

The belt setting will take place within the first 2 operating hours; when that time has elapsed, verify the spring length, according with the time intervals (periodicity) indicated in the "Maintenance operations' table".

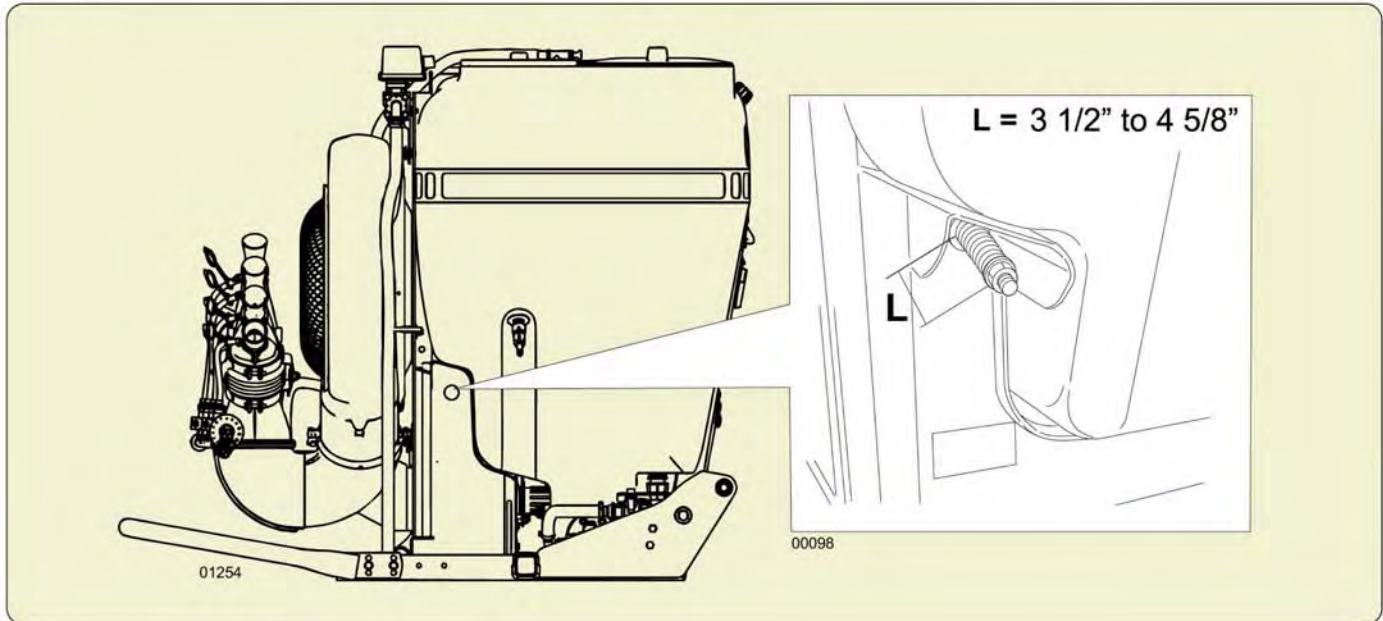

12.7 - PUMP BELT TENSIONER

Check length "L" of the spring (refer to picture): it should be in tension between 1 1/2" to 2".

If the value measured exceeds 2", tighten the belt tightener screw, up to get the minimum length 1 1/2".

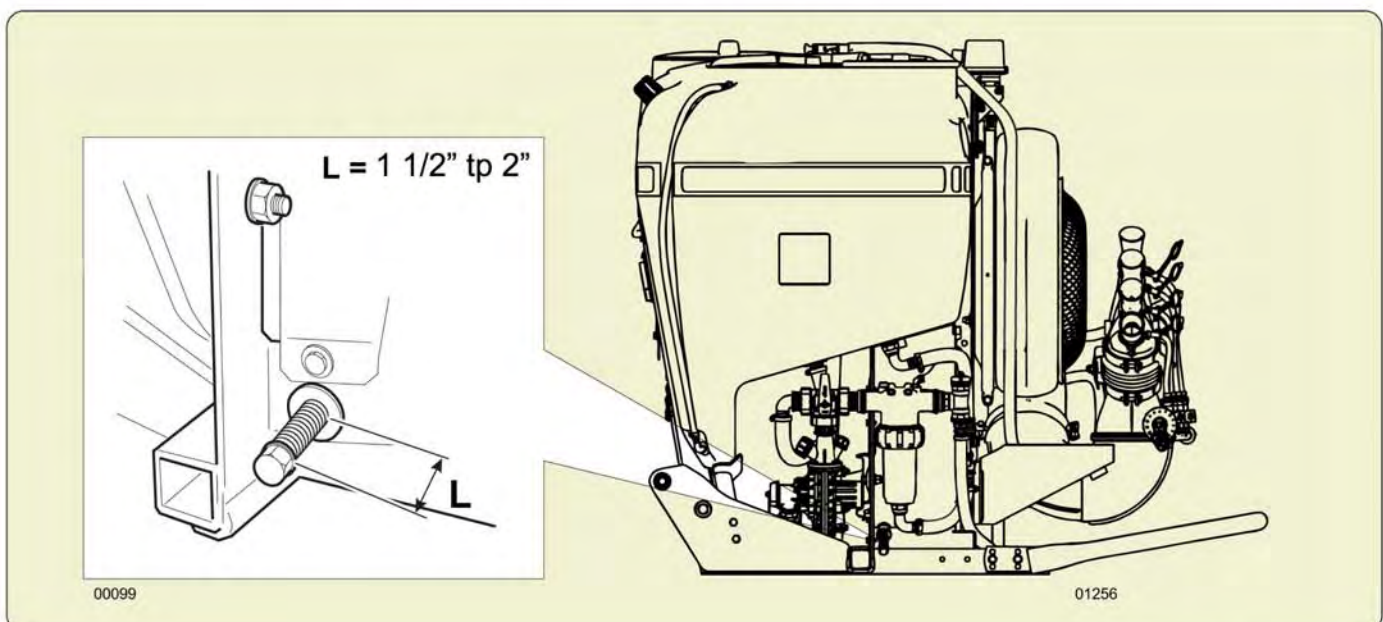

12.8 - TANK REMOVAL OR REPLACEMENT



It is recommended to have the operation performed by your dealer.



The operation has to be carried out by complete absence of liquid residuals both inside the tank and in the air circuit.

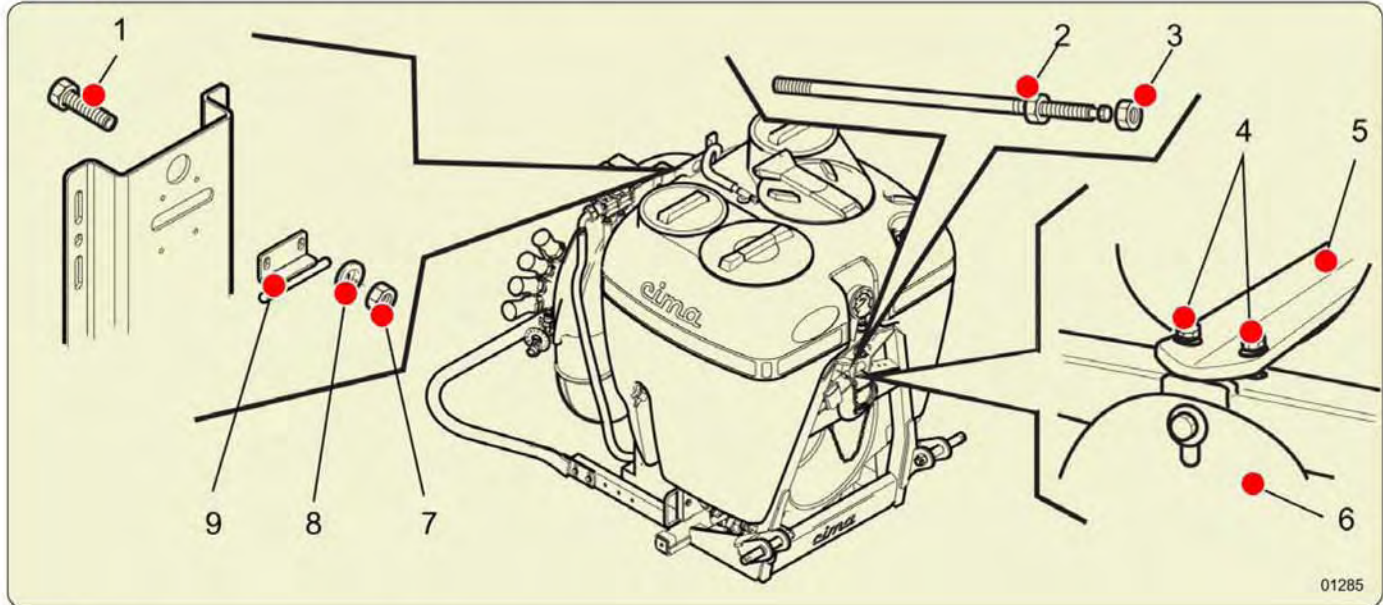

Removal:

1. Free the tank of its liquid and air connections.
2. Dismantle the mobile protection cover (6) of the coupling.
3. Remove the tank securing bracket (5), undoing the two screws (4) and the relevant washers.
4. Remove the tank securing bracket (9), undoing the two screws (1), the nuts (7) and the relevant washers (8).
5. Undo the external nut (3) of the tie rod.
6. Tighten the internal nut (2) of the tie rod, moving it away from the plate.
7. Undo the tie rod from its securing point, located in the rear part of the frame. Remove it through the large hole on the frame's plate.
8. Remove the tank.

Installation:

1. Position the main tank on the frame.
2. Re-position the tie-rod in its seat, in other words the smaller one, first inserting it through the big hole.
3. Tightly screw in and secure the tie rod to the rear plate of the frame.
N.B. Lock tightly and with utmost care
4. Unscrew the internal nut (2) of the tie rod, slightly tightening it against the plate.
5. Securely tighten the external nut (3) of the tie rod against the plate.
6. Reassemble the tank's securing bracket (9), fastening it with the 2 screws (1).
7. Reassemble the tank's securing bracket (5), fastening it with the 2 screws (4).



Before every intervention, check the proper tightening of the 2 securing screws of the tank's mounting bracket.

8. Reassemble the mobile protection lid of the disengaging device, by securing it with the relevant screw.
9. Reinstall the hydraulic and air connections.

12.9 - TABLE OF MAINTENANCE OPERATIONS

CHECK	SEASON START TREATMENTS	BEFORE EVERY TREATMENTS	END OF EVERY TREATMENTS	SEASON-END TREATMENT	RECOMMENDED FREQUENCY
Fan belt-tensioner spring: CHECK LENGTH 3 1/2" to 4 5/8"	YES	YES	**	**	**
Pump belt-tensioner spring: CHECK LENGTH 1 1/2" to 2"	YES	YES	**	**	**
Fan shaft support: CHECK OIL LEVEL	YES	YES	**	**	8
Fan shaft support: CHANGE OIL	**	**	**	YES	1 year
Tank: CHECK SECURING TIE ROD AND ANCHORING BRACKET	YES	YES	**	**	**
Fan belt-tensioner support: GREASING	**	**	**	YES	200 h
Overrunning Clutch: GREASING	**	**	**	YES	200 h
Filter: CHECK CLEANING	YES	YES	YES	YES	**
Tank level gauge: CHECK CLEANING AND GOOD CONDITIONS	YES	YES	YES	YES	**
Fittings and piping: CHECK GOOD CONDITIONS	YES	YES	**	YES	**
Clamps and fittings: CHECK FOR INTEGRITY, PERFECT SEALING AND TIGHTENING	YES	YES	**	**	**
Wheels: CHECK THE SCREW NUTS TIGHTENING AND TIRE PRESSURE	YES	YES	**	YES	**
Wheel hubs' fastening screws: CHECK THE TIGHTENING	YES	YES	**	YES	**
Liquid circuit and tank: COMPLETELY DRAIN AND WASH	**	**	YES	YES	**
Sprayer: EXTERIOR WASHING	**	**	YES	YES	**
Sprayer: STORAGE	**	**	**	YES	**

Tab_NP_004

	<i>It is necessary to disengage the drive outlet (PTO) and wait for it to stop rotating before repeating the filling operation.</i>	
PROBLEM:	CAUSE:	REMEDY:
Leakage and dripping from pump.	Non-sealing of the fittings and clamps connecting the piping to the pump.	Check for proper tightening of ring nuts and clamps. Check the efficiency of the seals. Replace parts that are possibly found to be defective.
	Mechanical sealing defective.	You may have to replace the pump.
Pressure drop of the liquid signalled by the pressure pump gauge.	Dirty main filter.	Clean the cartridge.
	The pump grill/filter is clogged.	Clean the grill/filter.
	Faulty sealing of the liquid.	Check the operation of the pump and tension of its belt. Check the proper tightening of ring nuts, fittings and clamps. Check the efficiency of the sealers and the integrity of the piping. Replace the parts that are possibly found to be defective.
	Gauge defective.	Replace the pressure gauge.
Suction or gauge connection pipe clogged.		Clean.
	Variations in the pressure of the liquid circuit (noted by the gauge)	Lack of seal of the pipes and/or valves.
Residue of product at the entrance of the gauge.		Clean.
Lack of seal of the o-ring gasket of the pump suction connection (cone).		Check the correct assembling and the efficiency of the o-ring gasket, if necessary replace the gasket.
Fan unit vibrating.	Dirty fan.	Wash, (wire brush if necessary).
Continuous noise together with vibrations of the fan group.	Fan shaft bearings breaking.	Replace bearings.
	Interference fan - case.	Contact your dealer service department.
Intermittent spray from distribution head.	Lack of seal of the circuit that goes from the tank (T1) suction pipes to the electro valves (E7) or liquid distributor (P8).	Carefully inspect all the points at which suction of air can take place, including as well those at which no liquid dripping is detected. Check the proper tightening of ring nuts, fittings and clamps. Check the efficiency of the sealers and the integrity of the piping. Reinstate the efficiency and replace parts that might have been found to be defective.
Intermittent spraying only on the one side of the distribution head.	Faulty sealing of the liquid circuit going from the manual (P8) or electrical (E7) distributor to the distribution point involved.	Same as above.

PROBLEM:	CAUSE:	REMEDY:
No spraying action delivered; totally.	Clogging up of the grill/filter on the pump, of the pump suction inside the tank or suction pipes of pump clogged up with deposits of hardened spray material.	Clean by removing the drain cap.
No spraying action delivered; totally or only on one side of the distribution head.	Electrical valve (E9) blocked by build-up in the closed position.	Remove the cover, act on the opening/closing control rod. Clean the distributor.
	Fuses of the electrical control panel (E10).	Replace the fuses.
	Power cable (W1) of the electrical panel interrupted or oxidized connectors of the electric distributor (E9).	Connect and possibly replace the defective components.
	Defective electrical connections.	Clean or replace.
	Pump defective (only in case of total delivery missing).	Order new pump and replace.
	Broken pump belt.	Replace the belt.
Large consumption of oil of the fan support.	Oil drain plug not adequately closed.	Check and adequately close then handle the filling up of the oil level.
	Damaged flexible oil waste pipe or damaged pipe fixing clamp.	Check adequately then handle the filling up of the oil level. Replace the damaged parts.
	Damaged seals.	Replace seals.
Noise (ticking) coming from the lower part of the mechanical drive at low R.P.M. when slowing down.	Lack of grease in the overrunning clutch.	Grease the clutch.
DISTRIBUTION HEADS:		
No spray coming from only one sprayhead.	Hole in Dial-A-Rate is plugged.	Clean out the hole. Take care to not damage the size of the hole.
	Valve to nozzle is closed.	Open valve.
	The head is clogged with chemical residue.	Clean the distribution head.
	The sprayer liquid system is defective.	Refer to the maintenance manual.
No spraying is coming out on <u>one</u> nozzle in the head.	The manifold valve is closed.	Open the valve.
	The manifold valve is clogged.	Clean the valve.
	The rubber hose connected to the nozzle is clogged.	Remove the hose and clean.
	The liquid outlet in the nozzle is clogged.	Remove the Venturi nozzle and clean outlet.
Intermittent spraying coming out on the one sprayhead only.	Not sealing of the liquid system at the Dial-A-Rate.	Check the tightness of the disc wing nuts. Check the o-ring in the Dial-A-Rate body and replace if necessary.
	Not sealing in the sprayer liquid system.	Check all fittings in the liquid system for tightness.



Stop the engine and remove the key from the tractor's control panel before any operation on the sprayer.

14.1 - REPLACEMENT OF PUMP CONTROL BELT

1. Remove the steel-plate guard located on the frame behind the pump, unscrewing the two securing screws.
2. Completely unscrew the tightener spring adjusting screw: the pump support plate will so freely turn.
3. Unscrew the fixing screw and turn the mobile protection cover to approach the tunnel of the disengagement.
4. Insert the pump control belt into the tunnel of fan disengagement. Feed the front part below the disengagement area and the rear area above, until it enters the upper pulley groove beyond the disengagement portion.
5. Insert the belt in the pump's pulley groove.
6. Reinstall the spring of the belt-tensioner according to the suggested tensioning conditions.
7. Re-assemble the steel-plate protection guards.

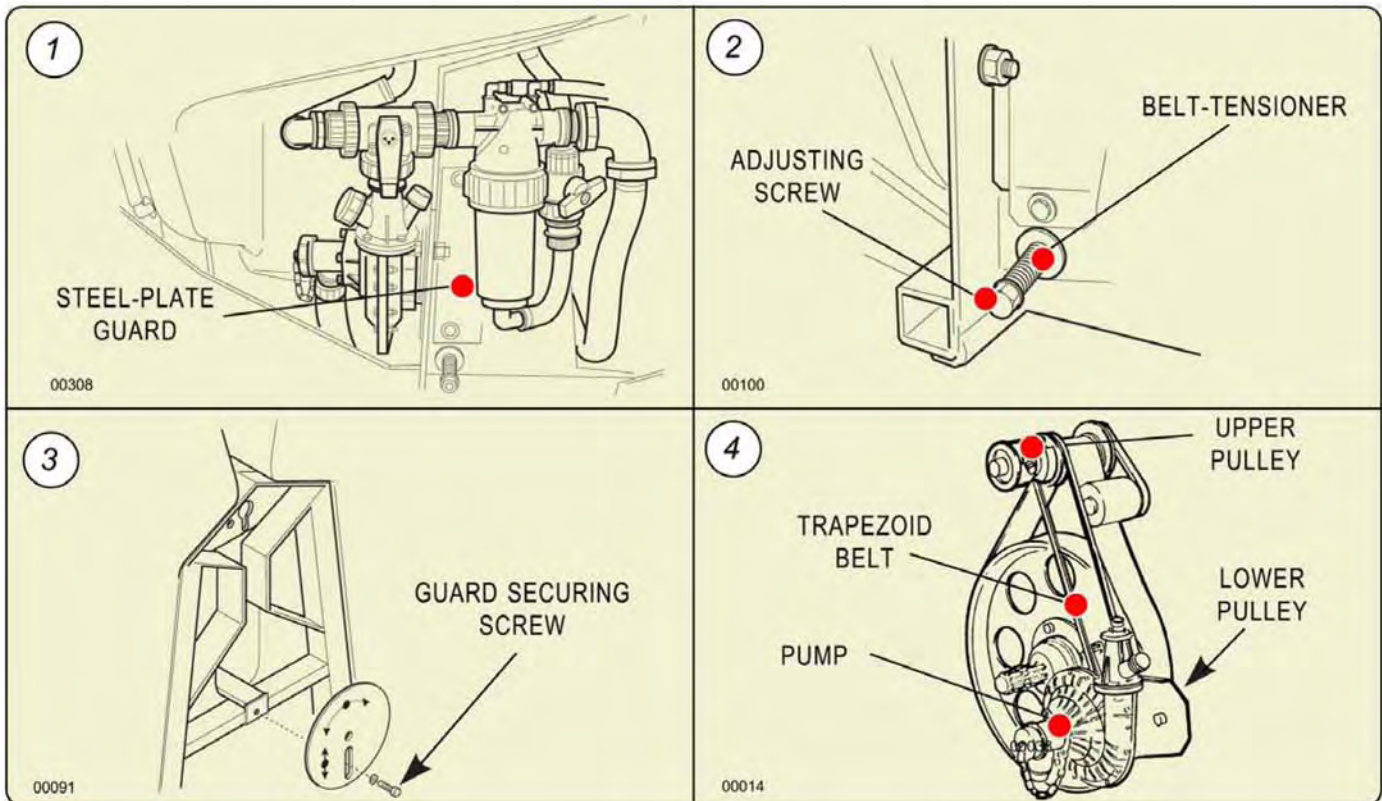

Carefully tighten the screws that were undone during the belt replacement.

14.2 - REPLACEMENT OF ELECTRICAL PANEL'S FUSES

1. Replace the faulty fuse and screw back the cover.
· Fuse: 10 A, delayed.



IF THIS DOES NOT CORRECT THE PROBLEM - CONTACT YOUR DEALER

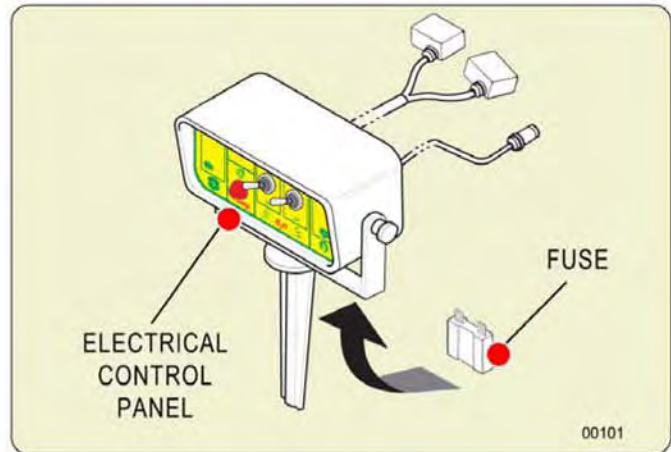

14.3 - PRESSURE GAUGE REPLACEMENT

1. Unscrew and decouple the pipe-holder (3) from the connection of the pressure gauge (1).
2. Unscrew the ring nut (2) and remove the pressure gauge (1).
3. Replace the faulty pressure gauge (1).
4. Mount the new pressure gauge, by carrying out in reverse order the steps mentioned for its removal.

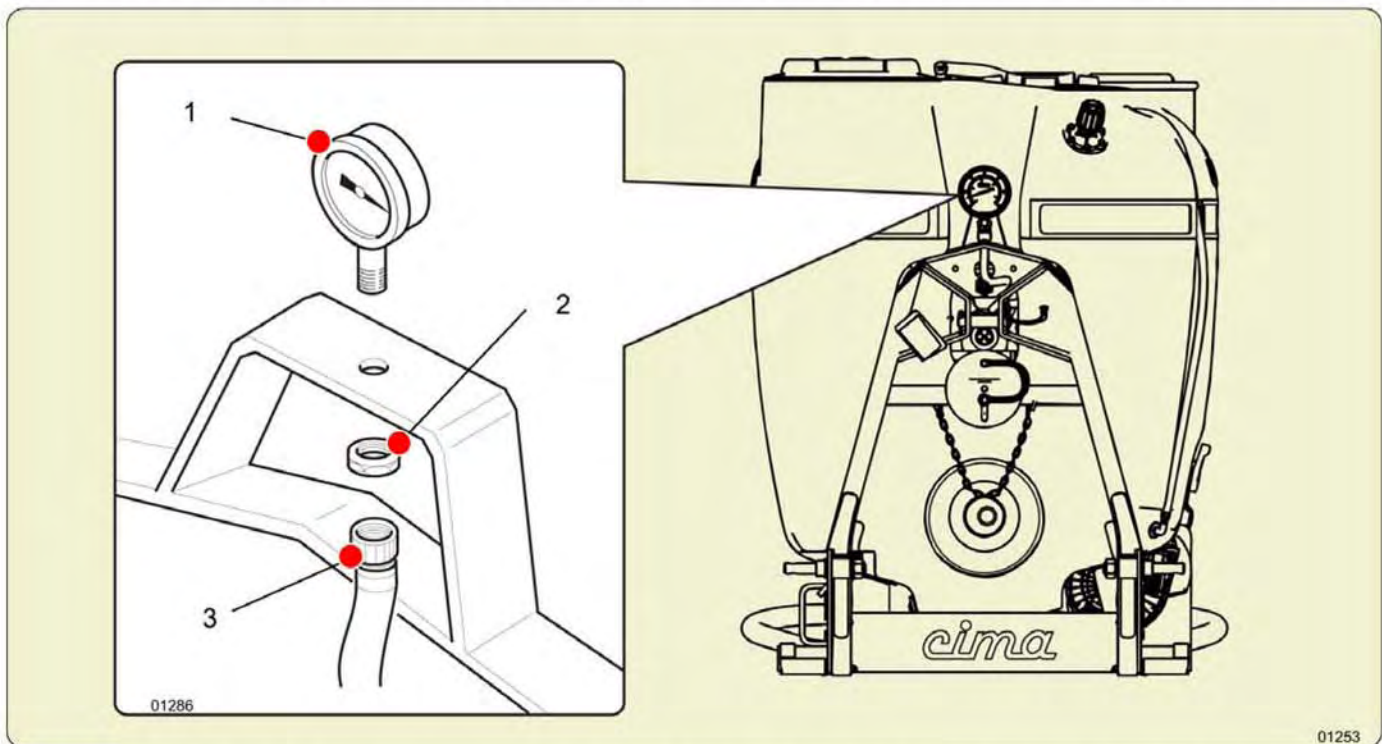

ANY OTHER INTERVENTION HAS TO BE CARRIED OUT AT A C.I.M.A. CUSTOMERS' SERVICING CENTER.

14.4 - INSPECTION AND CLEANING PUMP FILTER



The pump is provided by the suction side of a filter to prevent the accidental entry of foreign bodies in the pump body, such a possibility does not constitute a hazard and can only cause damage to the impeller shown by a drop in pressure reported by gauge..

The clogging of the filter pump causing an immediate lowering of pressure delivery.

If necessary check the cleanliness of the filter: #4

1. Position the lever of the three-way cock (P6) in position "C".
2. Position the lever of the three-way cock (P2) in position "C".
3. Unscrew the plug (1) and eventually remove the foreign body present in to the filter.
4. If necessary, unscrew the nuts (2) and remove the filter (4), to clean completely.
5. Replace the filter by paying attention to the conditions and the proper placement of the O.Ring (5).
6. Close the screw plug (1).
7. Position the lever of the three-way cock (P2) in position "A" - **WORKING**.
8. Position the lever of the three-way cock (P6) in position "A" - **WORKING**.

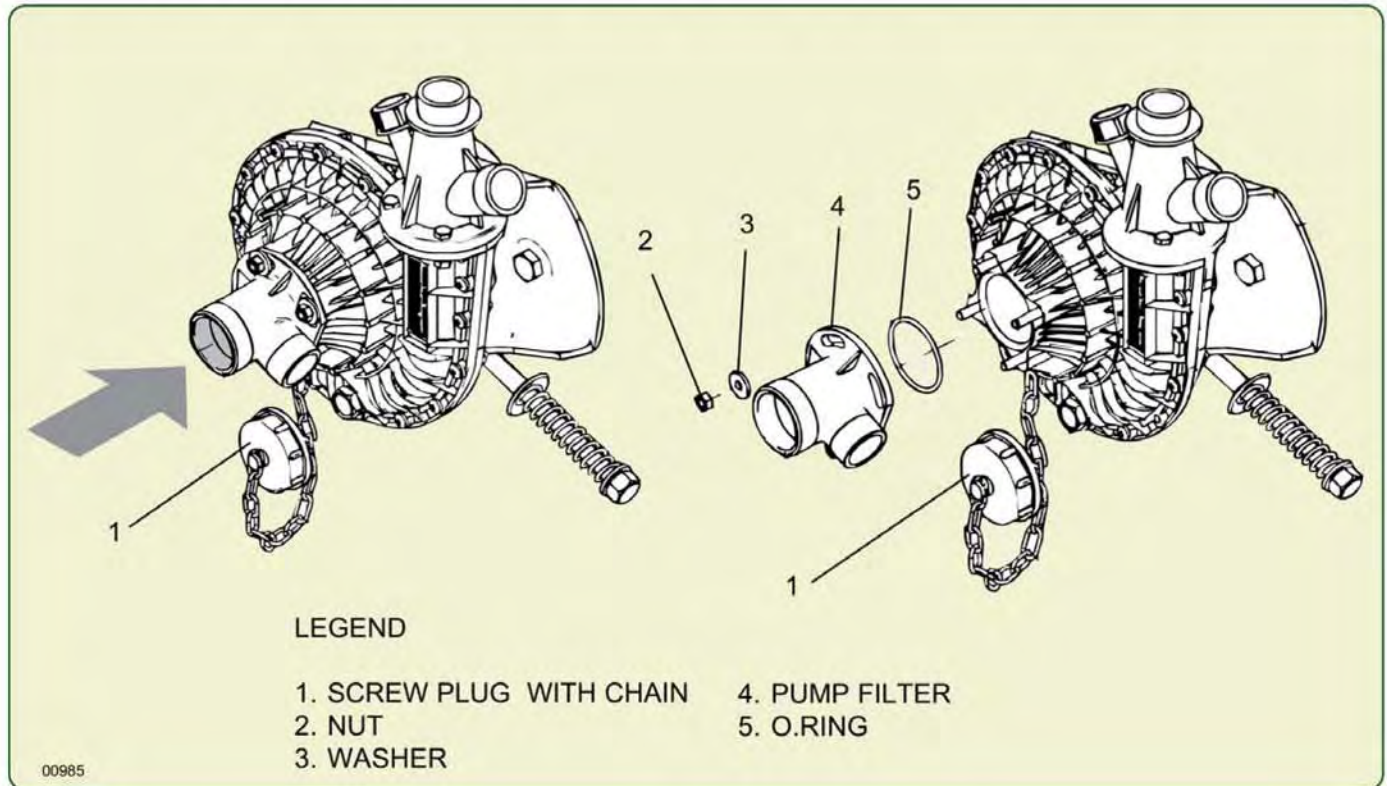

14.5 - LEVEL GAUGE CLEANING

1. With a suitable pliers release the clamp (1 and 2) fixing transparent tube of the level gauge.
2. Take off and remove the transparent tube (3).
3. Remove the red plastic ball (4).
4. Clean, with clean water, the transparent tube both in and outside.
5. If the cleaning is not satisfactory, replace the transparent tube (3).
6. Put the red plastic ball (4) into the transparent tube (3).
7. Install the transparent tube (3) making slip it on the rubber fittings.
8. Place the clamps (1 and 2) fixing the transparent tube (3) of the level gauge and close them with a suitable pliers.

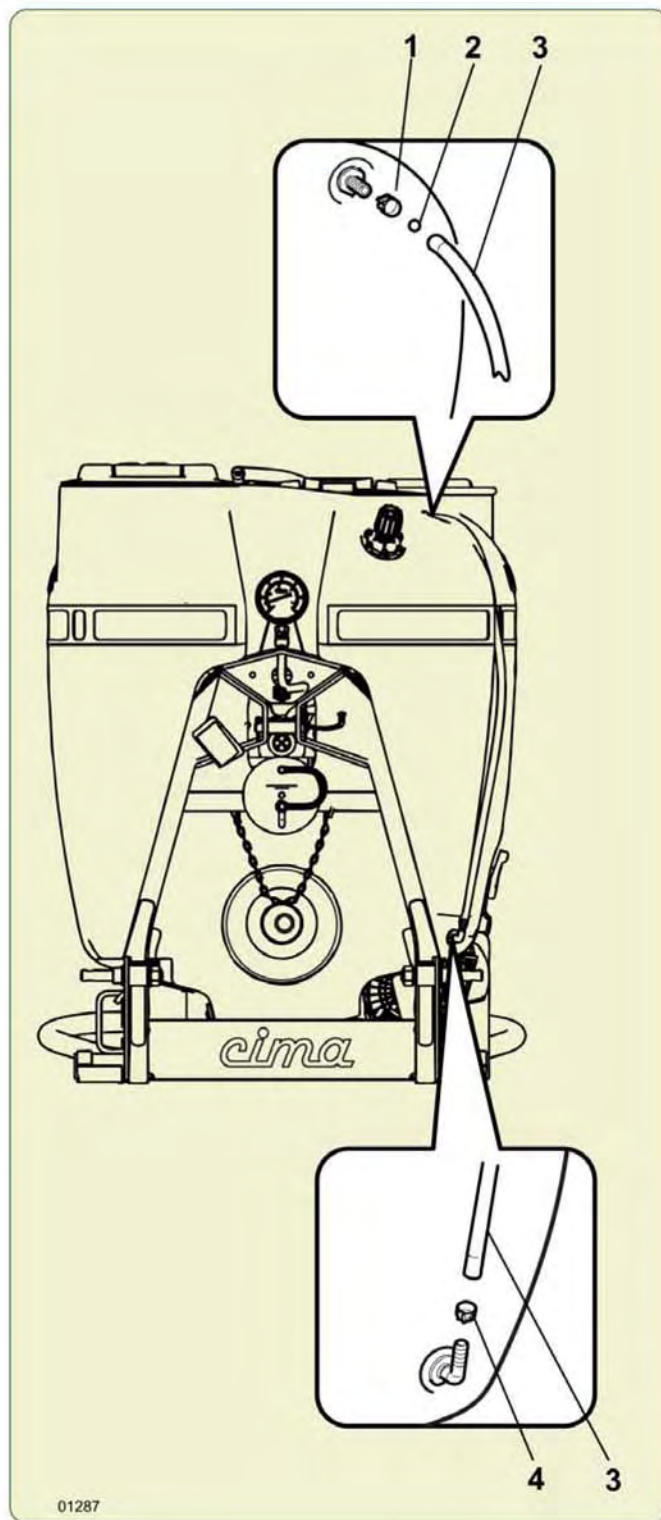

15.1 - LIQUID/AIR DIAGRAM

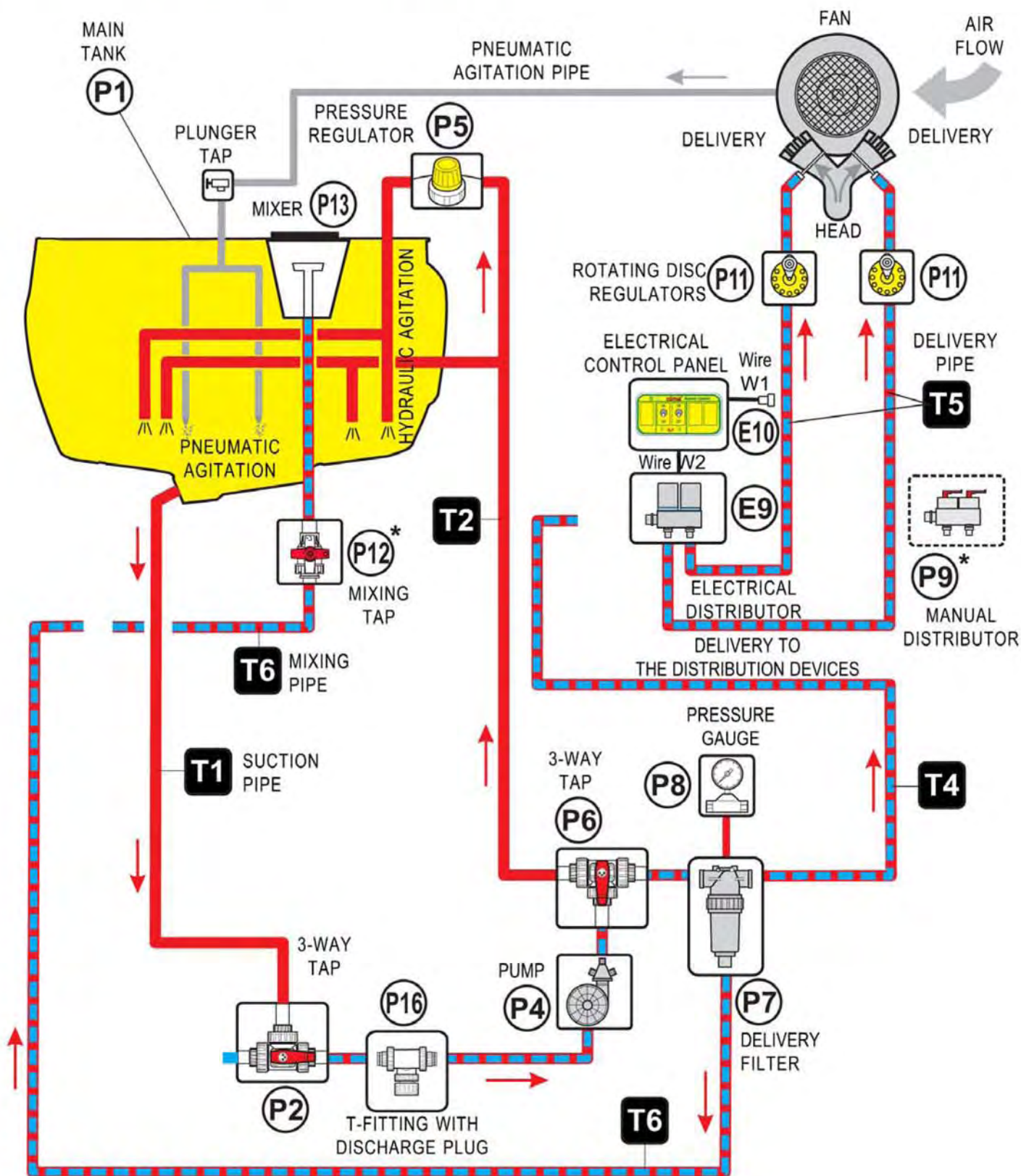

01288

* Optional

The logo for Gearmore Inc. features a stylized 'G' icon to the left of the text 'GEARMORE INC.' in a bold, sans-serif font. The entire logo is enclosed within a rectangular border.

GEARMORE, INC., warrants each new Gearmore product to be free from defects in material and workmanship for a period of twelve (12) months from date of purchase to the original purchaser. This warranty shall not apply to implements or parts that have been subject to misuse, negligence, accident, or that have been altered in any way.

Our obligation shall be limited to repairing or replacement of any part, provided that such part is returned within thirty (30) days from date of failure to Gearmore through the dealer from whom the purchase was made, transportation charges prepaid.

This warranty shall not be interpreted to render us liable for injury or damages of any kind or nature, direct, consequential or contingent, to person or property. This warranty does not extend to loss of crops, loss because of delay in harvesting or any other expenses, for any other reasons.

Gearmore in no way warrants engines, tires, or other trade accessories, since these items are warranted separately by these respective manufacturers.

Gearmore reserves the right to make improvements in design or changes in specification at any time, without incurring any obligations to owners or units previously sold.

Please be advised that all warranty work done by your dealer must be approved by Gearmore before work begins.

GEARMORE, INC.
13477 Benson Ave.
Chino, CA 91710

Always refer to and heed machine operating warning decals on machine.

*To validate the warranty on this product, please log-in to our website - www.gearmore.com.
You will find "warranty registration" listed at the top of our homepage.*