

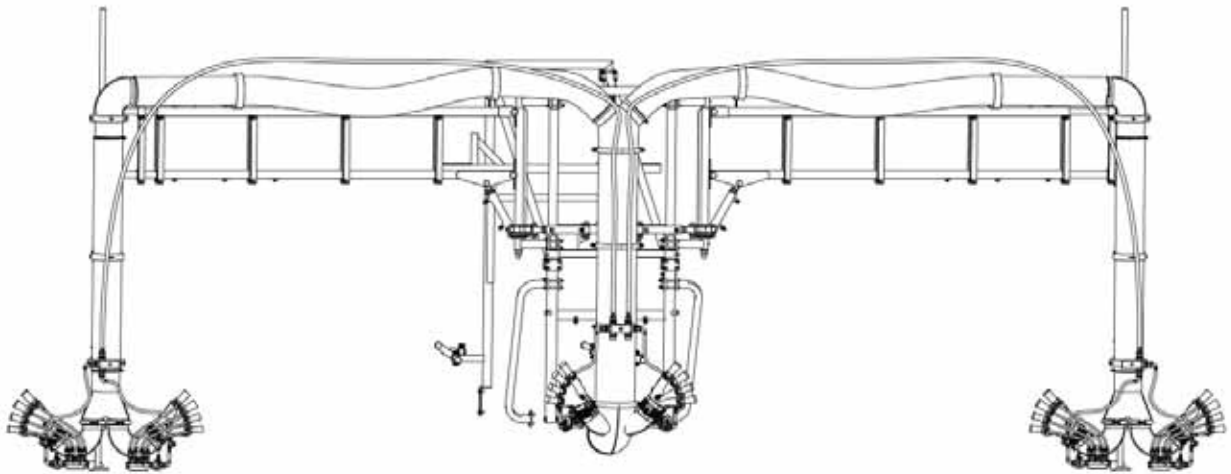

# VENTURI AIR SPRAYERS WRAP AROUND BOOM “A” SERIES



**Parts Manual For  
TS56MC55D12 "A" Boom  
For T55E2-2000**

**June 2013**

# TABLE OF CONTENTS

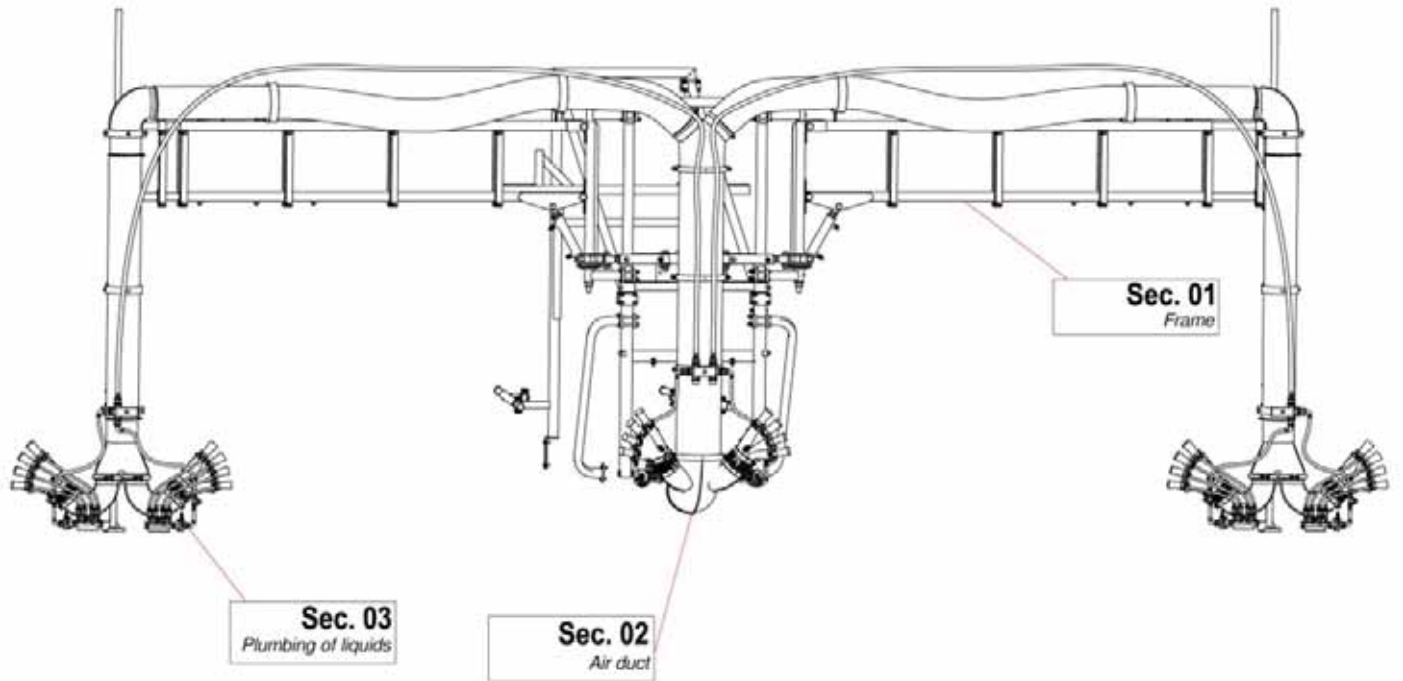

SECTION	DESCRIPTION	PAGE
<b>1</b>	<b>Complete Frame.....</b>	<b>1-6</b>
1.1	Central Section & Left Side.....	2
1.2	Right Side Section.....	3
1.3	Support Section.....	4
<b>2</b>	<b>Wrap-Around Boom Assembly .....</b>	<b>7-8</b>
<b>3</b>	<b>Liquid Flow Path.....</b>	<b>9-12</b>
3.1	Lower Center Heads.....	9
3.2	Lower Outer Heads.....	10
	Parts List.....	11-12
<b>4</b>	<b>Liquid Manifold .....</b>	<b>13</b>
<b>5</b>	<b>Dial-A-Rate .....</b>	<b>14</b>

**Sec. 01 - COMPLETE FRAME - ROW WIDTHS OF 7'-6" TO 10'**

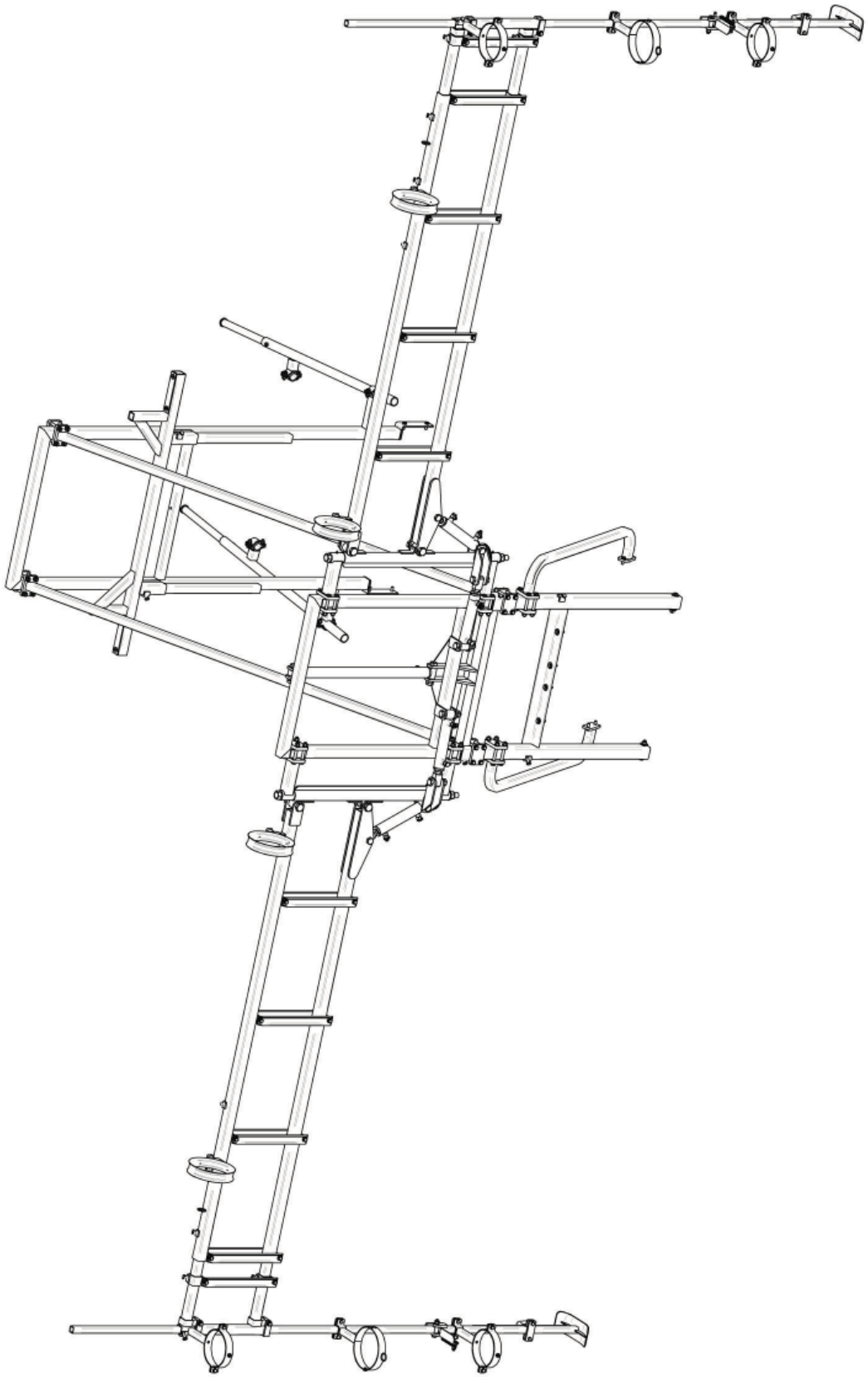

# Sec. 01.1 - CENTRAL SECTION & LEFT SIDE

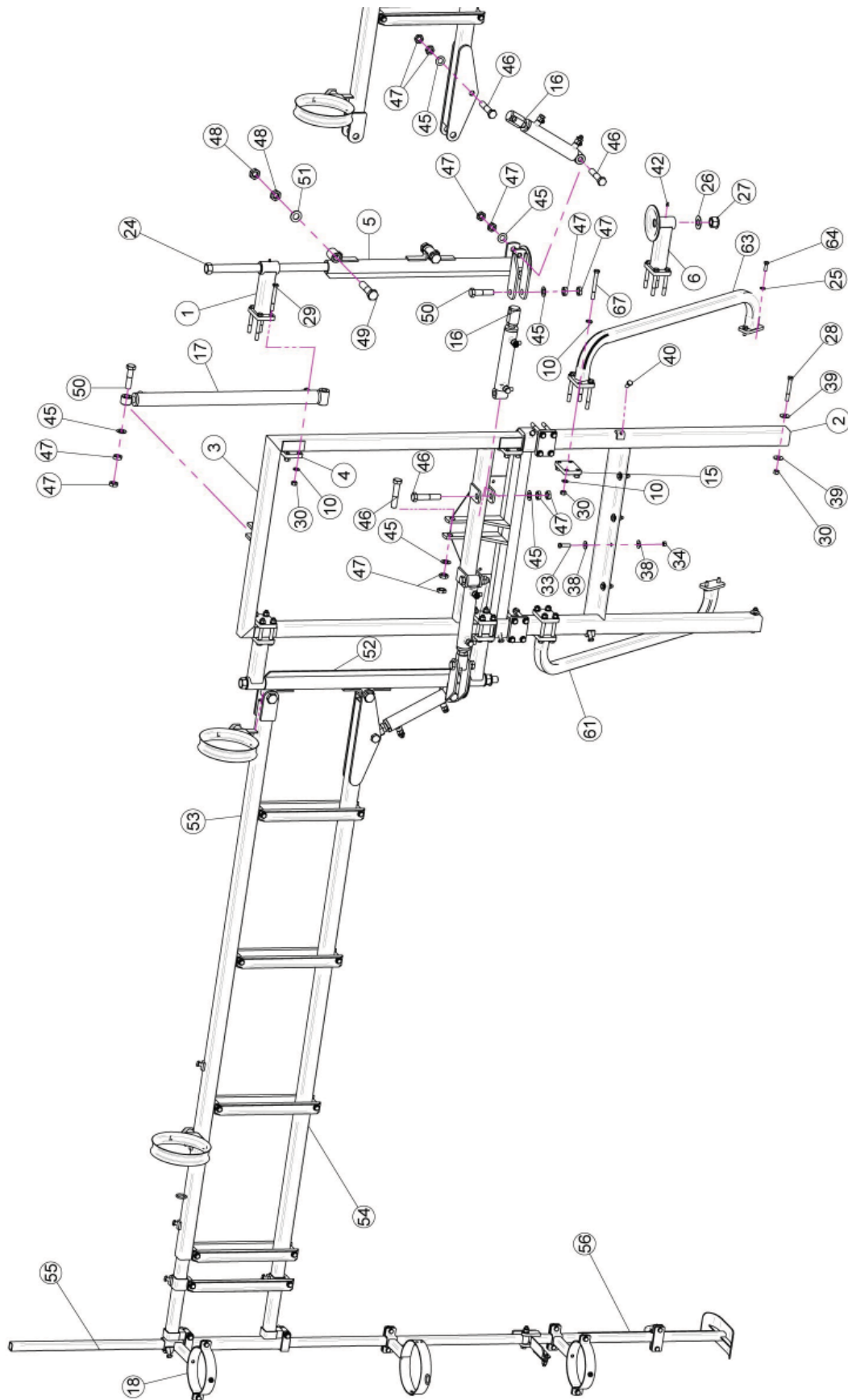

# Sec. 01.2 - RIGHT SIDE SECTION

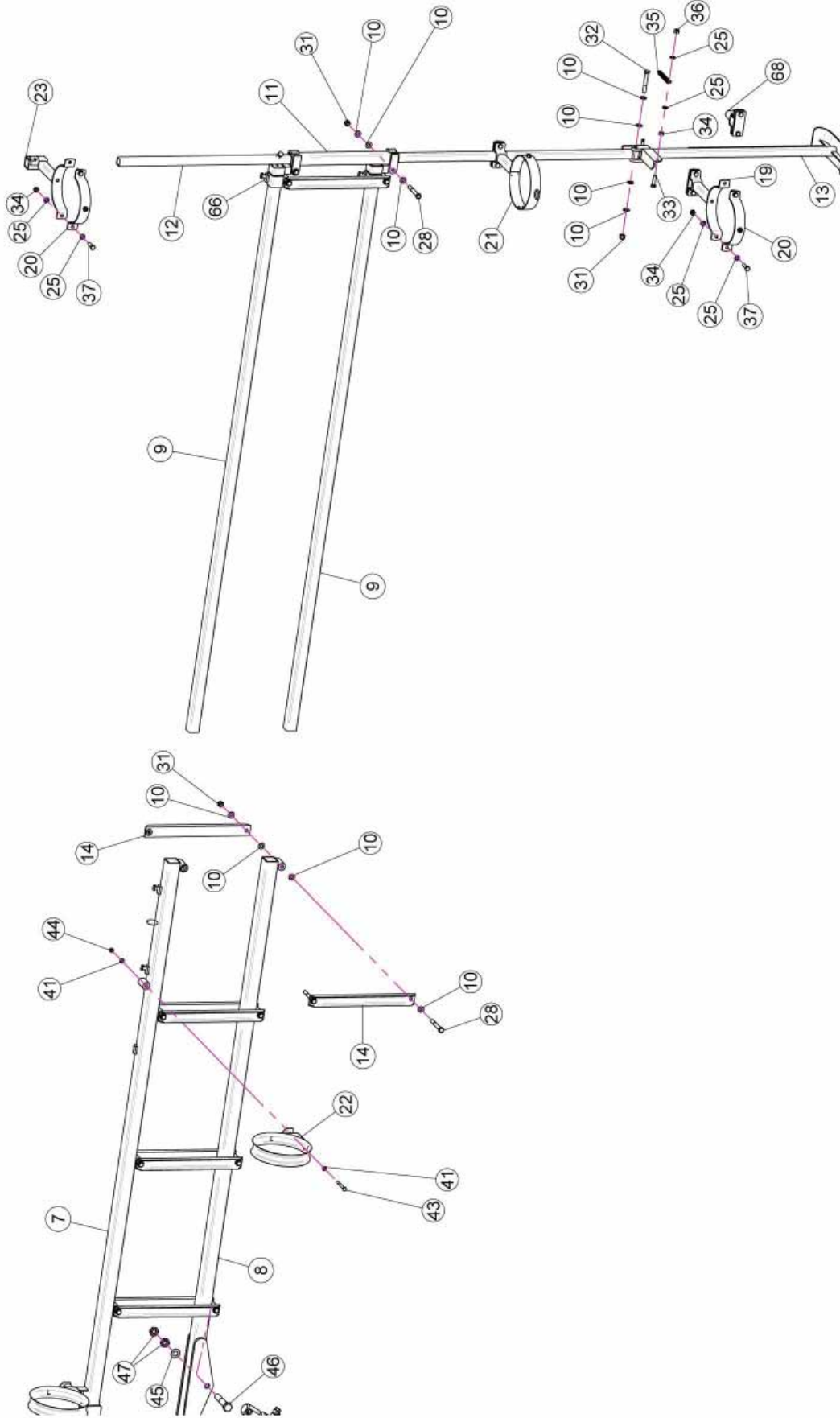

## Sec. 01.3 - SUPPORT SECTION

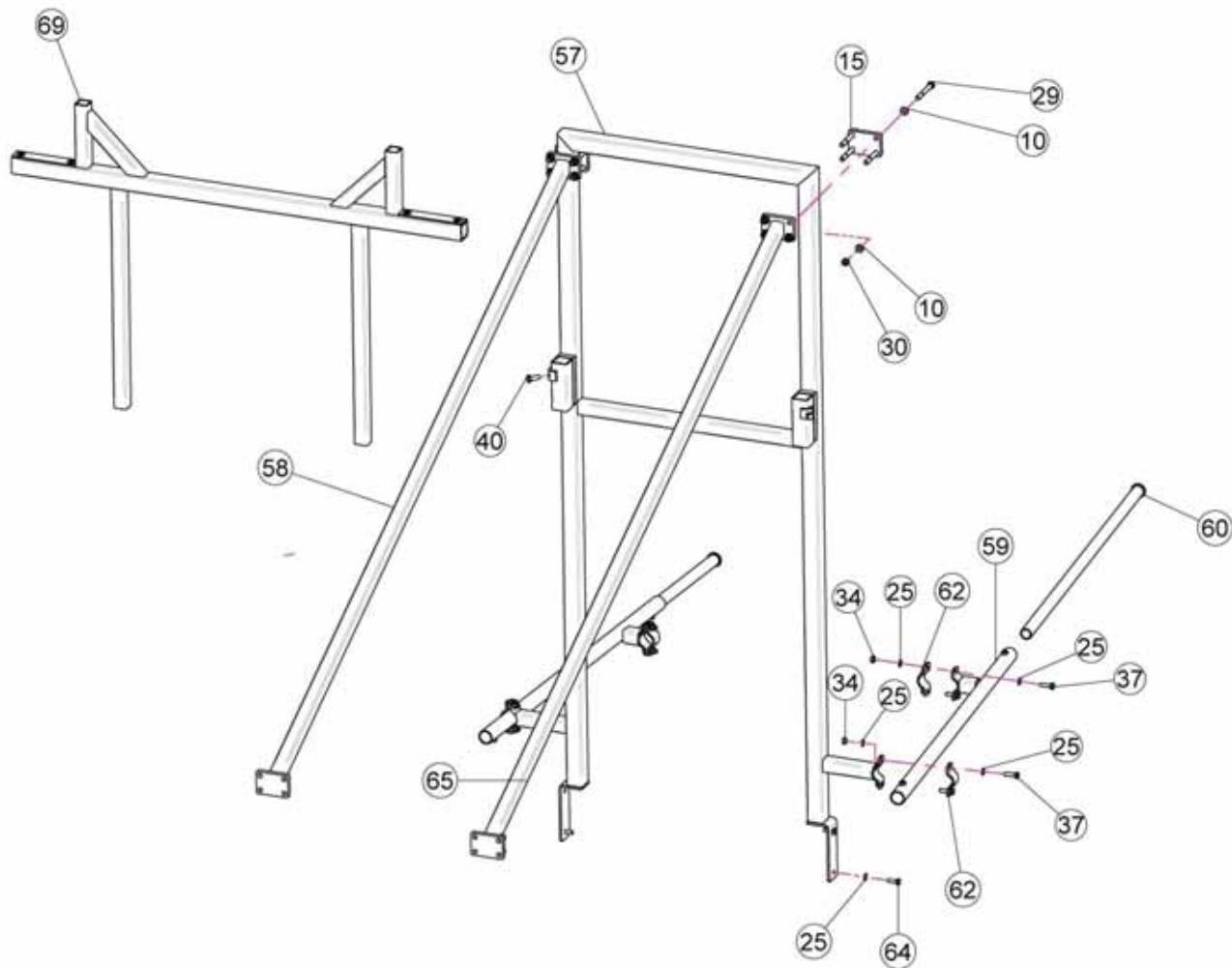

<u>REF.</u>	<u>QTY.</u>	<u>PART NO.</u>	<u>DESCRIPTION</u>
1	2	20.939.000	Arms Pipes Without Disk
2	1	21.019.300	Central Frame
3	1	21.024.300	Sliding Frame
4	4	20.937.000	Bracket
5	1	20.958.201	Right Arms Rotation Pipe
6	2	20.939.100	Arms Pipes With Disk
7	1	21.023.200	High Right Arm
8	1	21.022.300	Right Side Arm
9	4	21.020.200	Sliding Arm
10	162	RP.012.000	Washer D.12
11	2	20.884.101	Sliding Pole Support
12	1	21.027.000	Right Higher Going Down Pipe
13	1	20.948.002	Right Lower Going Down Pipe

## Sec. 01 - COMPLETE FRAME PARTS

<u>REF.</u>	<u>QTY.</u>	<u>PART NO.</u>	<u>DESCRIPTION</u>
14	18	20.879.200	Union Leg Lamin
15	6	20.937.000	Bracket
16	4	02.838.100C	Side Jack With Regulator
17	1	02.840.01C	Complete Central Jack
18	1	50.209.100	Right Going Down Arm
19	2	50.209.200	Going Down Arm
20	4	20.503.002	Half Clamp With Nut M10
21	2	50.211.000	Bracket
22	4	50.040.025	Stainless Steel Guide Ring
23	1	50.209.000	Left Going Down Arm
24	2	20.910.300	Arm Pin Rotation
25	44	RP.010.000	Washer D.10
26	2	RP.024.000	Washer D.24
27	2	DA.024.0AG	Self Locking M24
28	26	TE.012.090	Screw TE M12 x 90
29	24	TE.012.100	Screw TE M12 x 100
30	42	D0.12.5587G	M12 Nut
31	26	DA.012.0AG	Self Locking Nut M12
32	2	TE.012.080	Bolt TE M12 x 80
33	6	TE.010.040T	Screw TE M10 x 40
34	22	D0.10.5587G	Nut M10
35	2	S0.480.000	Spring
36	2	DA.010.0AG	Self Locking Nut M10
37	16	TE.010.035T	Screw TE 10 x 35
38	8	RP.010.030	Washer D. 10 x 30 MM
39	4	RP.012.036	Washer D12 x 36
40	24	TE.012.030T	Screw TE 12 x 30
41	10	RP.008.000	Washer D.8
42	2	ID.006.001	Greaser
43	5	TE.008.070	Screw TE M8 x 70
44	5	DA.008.0AG	Self Locking Nut M8
45	10	RP.020.000	Washer D.20
46	7	TE.020.100	Screw TE M20 x 100
47	16	D0.20.5589G	Lower Nut M20
48	8	DO.24.5589G	Lower Nut M24
49	4	TE.024.100	Screw TE M24 x 100
50	3	TE.020.080	Screw TE M20 x 80
51	4	RP.024.000	Washer D.24
52	1	20.959.201	Left Arm Rotation Pipe

## Sec. 01 - COMPLETE FRAME PARTS CONTINUED...

<u>REF.</u>	<u>QTY.</u>	<u>PART NO.</u>	<u>DESCRIPTION</u>
53	1	21.026.200	High Left Arm
54	1	21.025.300	Left Side Arm
55	1	21.027.100	Left Higher Going Down Pipe
56	1	20.948.102	Left Lower Going Down Pipe
57	1	50.226.101	Tie-Rod
58	1	50.228.000	Left Tie Rod
59	2	50.231.000	Anchor Tube
60	2	50.227.000	Sliding Buffer
61	1	50.232.000	Left Tie Rod
62	4	S0.493.000	Shaped Plate Fixing
63	1	50.232.100	Right Tie Rod
64	8	TE.010.030T	Screw TE M10 x 30
65	1	50.228.100	Right Tie Rod
66	4	20.969.100	Sliding Union For Arms
67	16	TE.012.110	Screw TE M12 x 110
68	2	20.943.100	Arm Block
69	1	50.230.001.Z	Arm Support Zinced



# Sec. 02 - WRAP-AROUND BOOM ASSEMBLY

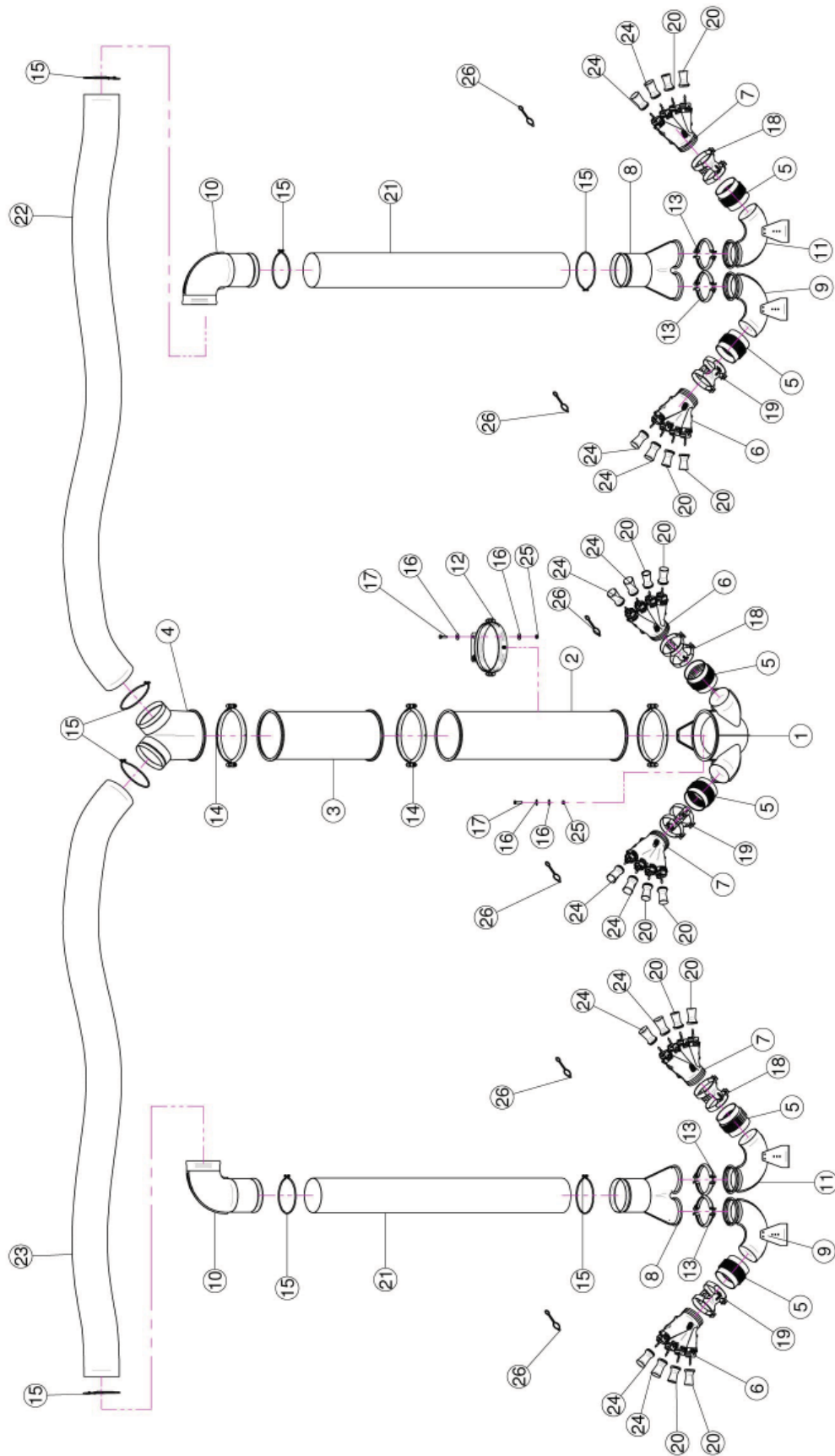

## Sec. 02 - WRAP-AROUND BOOM ASSEMBLY PARTS

<u>REF.</u>	<u>QTY.</u>	<u>PART NO.</u>	<u>DESCRIPTION</u>
1	1	05.843.100	Body D.250 With 2 Outlets D.120
2	1	50.075.000	Extension D.250 x 1000
3	1	21.100.060	Extension D.250 x 600
4	1	20.649.000	Body D.250 With 2 Outlets D.175
5	8	02.021.000	Flexible Sleeve
6	3	20.014.000DX	Four Outlets
7	3	20.014.000SX	Four Outlets
8	2	50.210.000	Body D.175 With 2 Outlets D.120
9	2	04.845.400	Elbow 130° D.120
10	2	20.650.100	Elbow D.175 90° With 2 Rubber Holders D.180
11	2	04.845.300	Elbow 130° D.120
12	1	20.504.000	D.250 Clamp Heads Fixing
13	4	04.027.000	Pipe Clamp D.150
14	3	05.813.000	Clamp D.275
15	8	F0.180.000	Clamp D.180
16	6	RP.010.030	Washer D.10 x 30 mm
17	3	TE.010.035T	Screw TE 10 x 35
18	3	21.080.000	Right Clamp Ø 127
19	3	21.081.000	Left Clamp Ø 127
20	12	00.006.050	Nozzle 6/50
21	2	02.388.000	Hose D.180 L=1500 (Per Foot)
22	1	02.388.000	Polyurethane Hose D.180 L=5000 (Per Foot)
23	1	02.388.000	Polyurethane Hose D.180 L=5000 (Per Foot)
24	12	00.008.050	Nozzle 8/50
25	3	D0.10.5587G	Nut M10
26	24	20.697.000	Nozzle Stop

### 20.014.000

1	4	20.016.01C	Tube With Liquid Outlet
---	---	------------	-------------------------

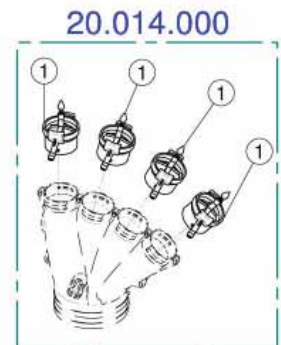

## Sec. 03 - LIQUID FLOW PATH

### Sec. 03.1 - LIQUID FLOW PATH - LOWER CENTER HEADS

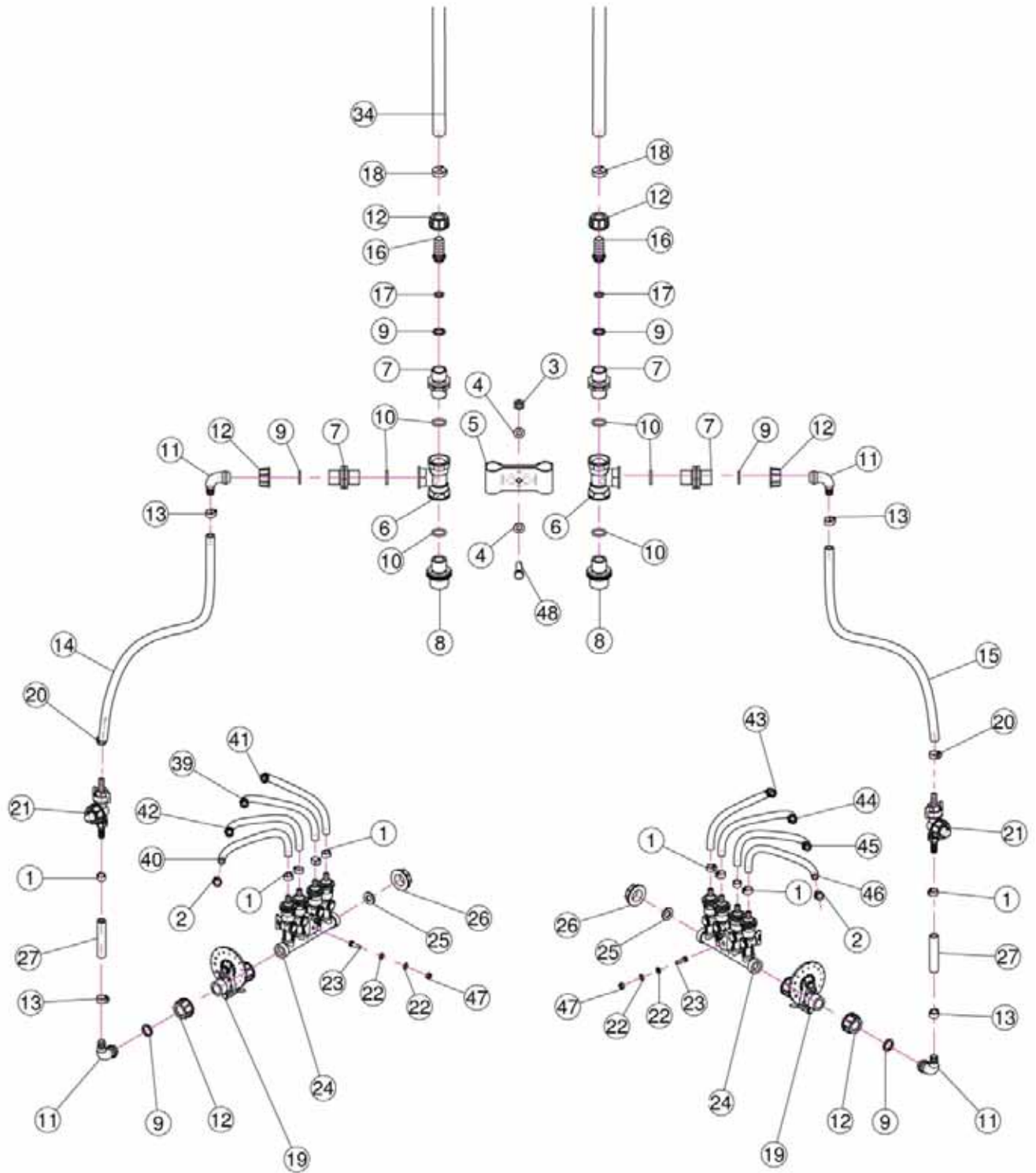

## Sec. 03.2 - LIQUID FLOW PATH - LOWER OUTER HEADS

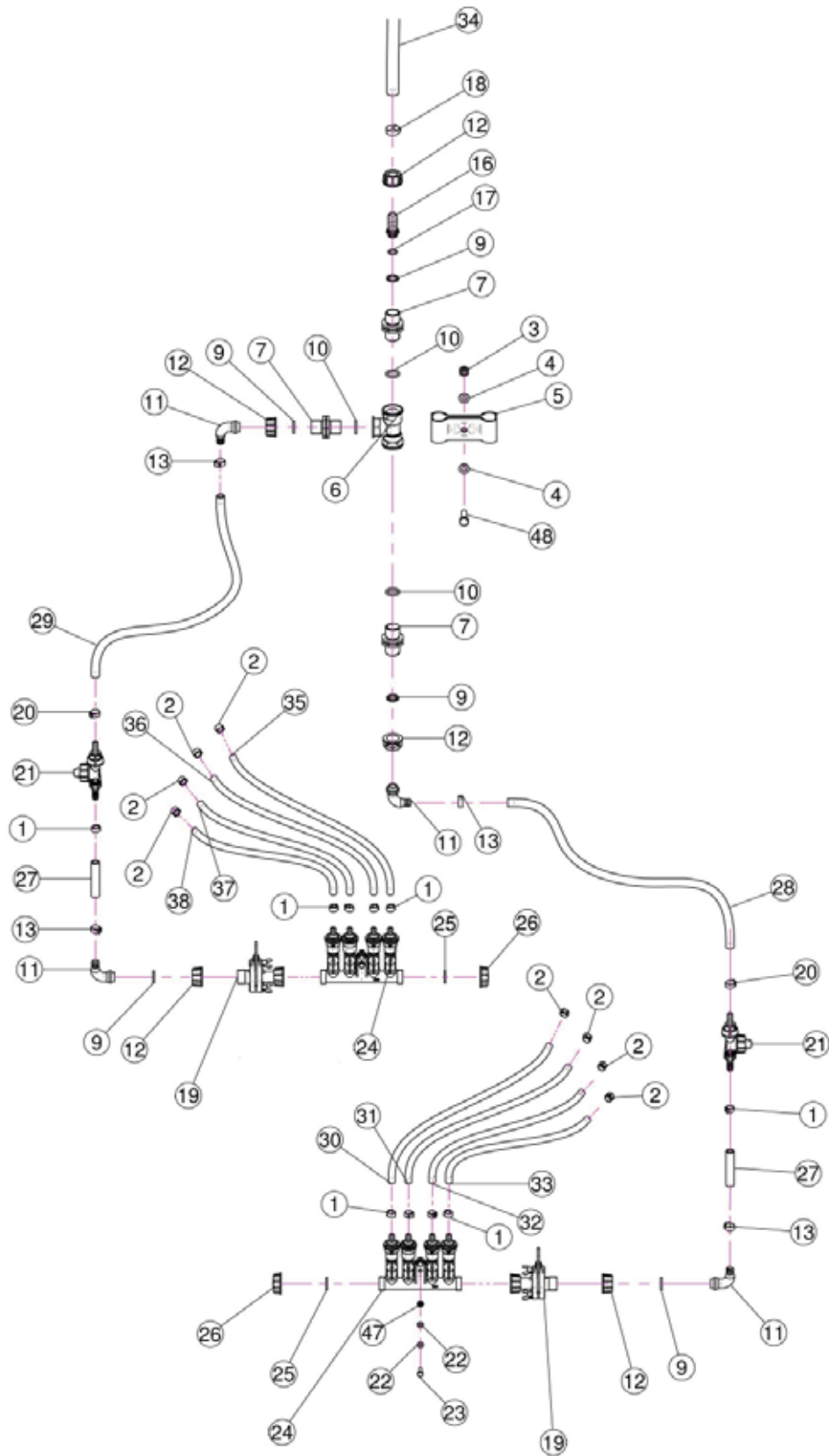

## Sec. 03 - LIQUID FLOW PATH PARTS

<u>REF.</u>	<u>QTY.</u>	<u>PART NO.</u>	<u>DESCRIPTION</u>
1	30	FC.013.5.015	Hose Clamp
2	24	FC.012.5.014	Hose Clamp
3	3	DA.010.0AG	Self Locking Nut M10
4	6	RP.010.000	Washer D.10
5	3	02.999.000	T Union Fixing Bracket
6	4	02.396.000	Union 3/4" - 3/4" F.
7	10	02.380.000	Nipple 3/4"
8	2	02.293.000	1" M - 3/4" M Reducer Nipple
9	16	02.349.000	17 x 23 x 3 Flat Gasket
10	12	OR.004.081	20.22 x 3.53 O-Ring Gasket
11	12	00.055.046R	Curved Union With R.H. D.14
12	16	00.055.045	3/4" Fly Nut
13	12	FC.016.5.018	Hose Clamp 16.5 - 18
14	1	02.213.000	Hose D.10 x 16 L=600 (Per Foot)
15	1	02.213.000	Hose D.10 x 16 L=600 (Per Foot)
16	4	02.002.000	Straight Union 3/4" R.H. 18
17	4	OR.000.117	13.1 x 18.34 x 2.62 O-Ring Gasket
18	4	FC.022.5.024	Hose Clamp 22.5 - 24
19	6	02.150.000	Rotation Disk Regulation
20	6	FC.015.5.017	Hose Clamp
21	6	00.226.05C	Complete Antidrop
22	24	RP.006.000	Washer D.6
23	12	TE.006.020T	Screw TE M6 x 20
24	6	02.008.304C	4 Taps Liquid Manifold
25	6	02.030.010	Gasket
26	6	02.182.000	Female 3/4" Cap
27	6	02.213.000	Hose D.10 x 16 L=70 (Per Foot)
28	2	02.213.000	Hose D.10 x 16 L=900 (Per Foot)
29	2	02.213.000	Hose D.10 x 16 L=900 (Per Foot)
30	2	02.217.000	Hose D.8 x 13 L=410 (Per Foot)
31	2	02.217.000	Hose D.8 x 13 L=380 (Per Foot)
32	2	02.217.000	Hose D.8 x 13 L=380 (Per Foot)
33	2	02.217.000	Hose D.8 x 13 L=290 (Per Foot)
34	2	02.211.000	Hose D.16 x 23 L=6000 (Per Foot)
35	2	02.217.000	Hose D.8 x 13 L=410 (Per Foot)
36	2	02.217.000	Hose D.8 x 13 L=380 (Per Foot)
37	2	02.217.000	Hose D.8 x 13 L=330 (Per Foot)
38	2	02.217.000	Hose D.8 x 13 L=290 (Per Foot)
39	1	02.217.000	Hose D.8 x 13 L=390 (Per Foot)
40	1	02.217.000	Hose D.8 x 13 L=290 (Per Foot)

## Sec. 03 - LIQUID FLOW PATH PARTS CONTINUED...

<u>REF.</u>	<u>QTY.</u>	<u>PART NO.</u>	<u>DESCRIPTION</u>
41	1	02.217.000	Hose D.8 x 13 L=410 (Per Foot)
42	1	02.217.000	Hose D.8 x 13 L=330 (Per Foot)
43	1	02.217.000	Hose D.8 x 13 L=410 (Per Foot)
44	1	02.217.000	Hose D.8 x 13 L=390 (Per Foot)
45	1	02.217.000	Hose D.8 x 13 L=330 (Per Foot)
46	1	02.217.000	Hose D.8 x 13 L=290 (Per Foot)
47	12	D0.06.5588G	Nut M6
48	3	TE.010.035T	Screw TE 10 x 35

## Sec. 04 - MANIFOLD & SHUT-OFF VALVES

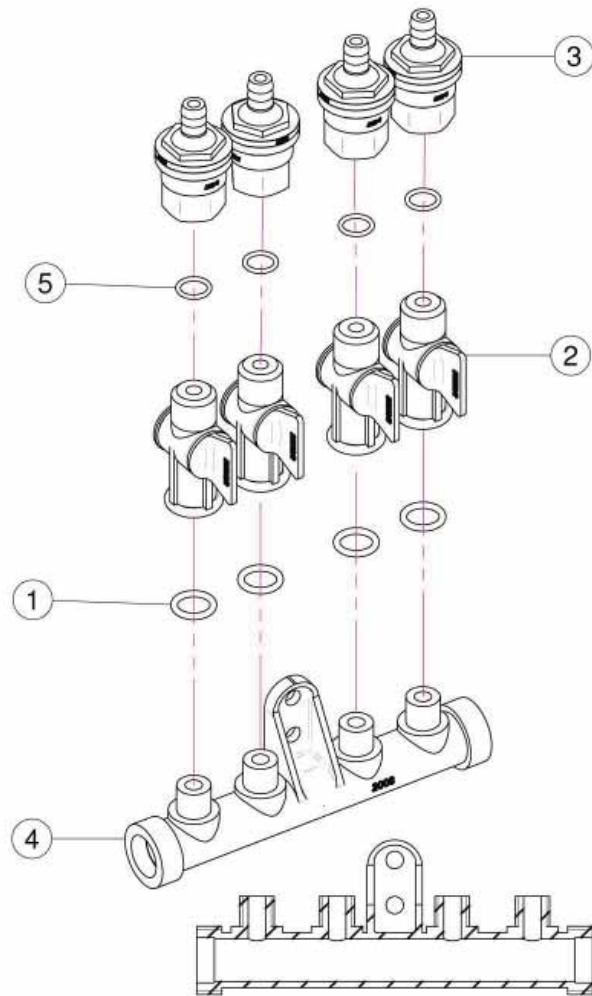

<u>REF.</u>	<u>QTY.</u>	<u>PART NO.</u>	<u>DESCRIPTION</u>
		<b>02.008.304C</b>	<b>Complete Assembly</b>
1	4	OR.000.117	13.1 x 18.34 x 2.62 O-Ring Gasket
2	4	20.202.100	Tap Assembly
3	4	00.227.01C	Anti-Drip Valve
4	1	02.008.000	Sprayheads Liquid Manifold
5	4	OR.002.043	10.82 x 14.38 x 1.78 Nbr 70 O-Ring Gasket

## Sec. 05 - DIAL-A-RATE

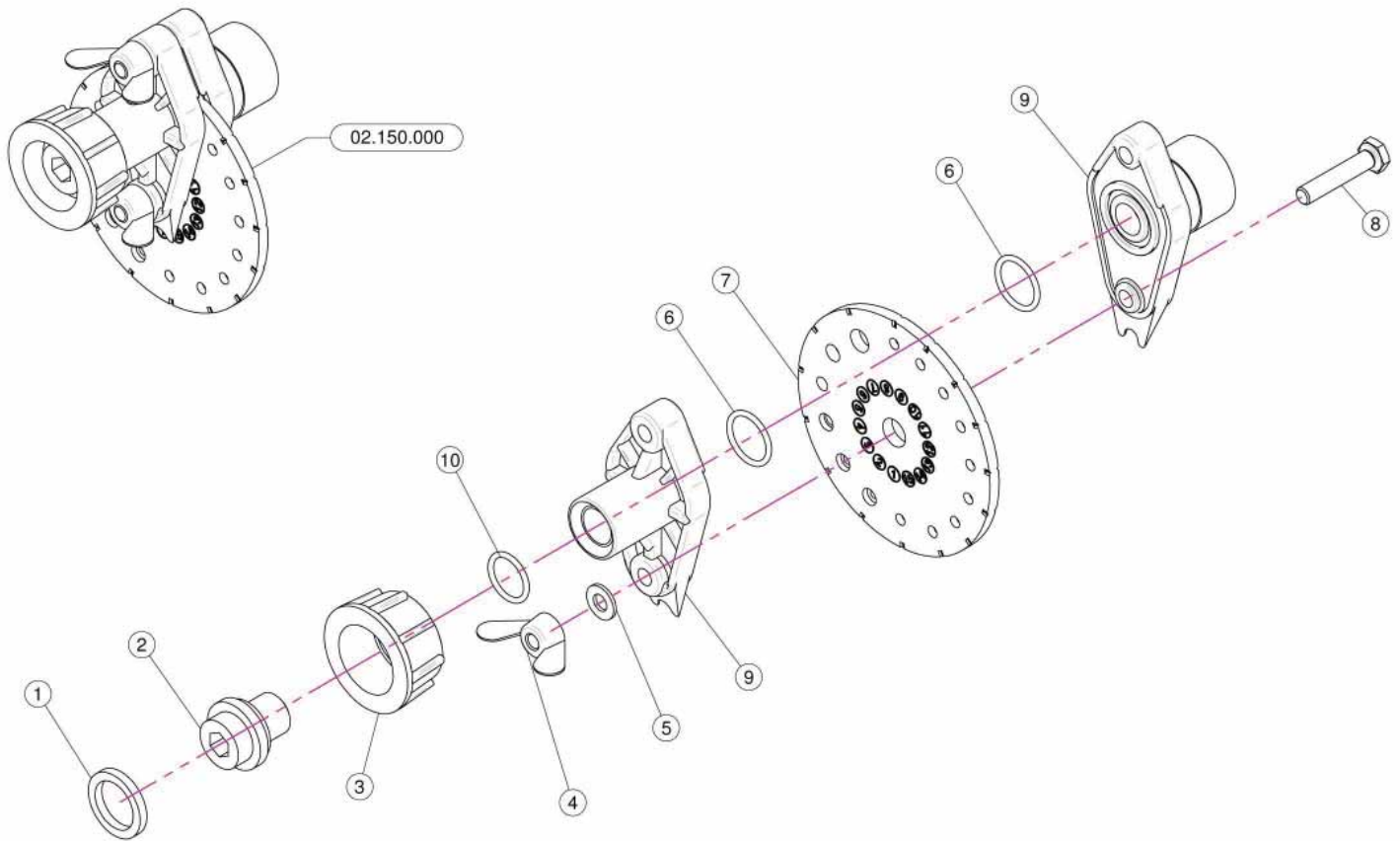

<u>REF.</u>	<u>QTY.</u>	<u>PART NO.</u>	<u>DESCRIPTION</u>
1	1	02.349.000	17 x 23 x 3 Flat Gasket
2	1	02.117.000	Adapter Nipple
3	1	00.055.045	3/4" Fly Nut
4	2	DF.OTT.006	Wing Nut M6
5	2	RP.006.000I	INOX Washer D.6
6	2	OR.002.062	D.15.6 x 1.78 O-Ring
7	1	02.148.000	Regulator Disc
8	2	TE.006.030I	INOX M6 x 30 Bolt
9	1	02.147.000	Regulator Body
10	1	OR.003.050	O-Ring D.12.37 x 2.62