

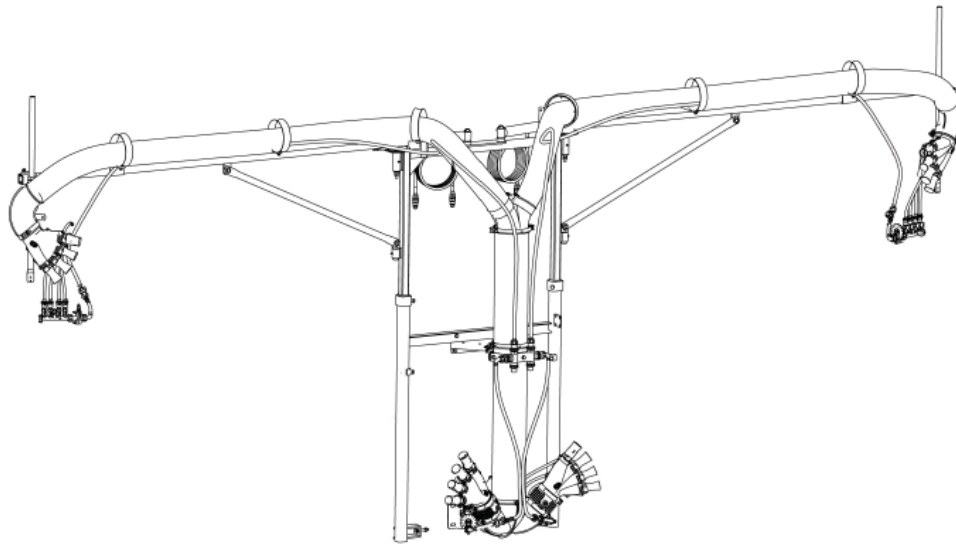

VENTURI AIR SPRAYERS 2 ROW DISTRIBUTION HEAD



**Parts Manual For
TCF2M2M50P12L Distribution Head
For P50 Sprayers**

June 2013

TABLE OF CONTENTS

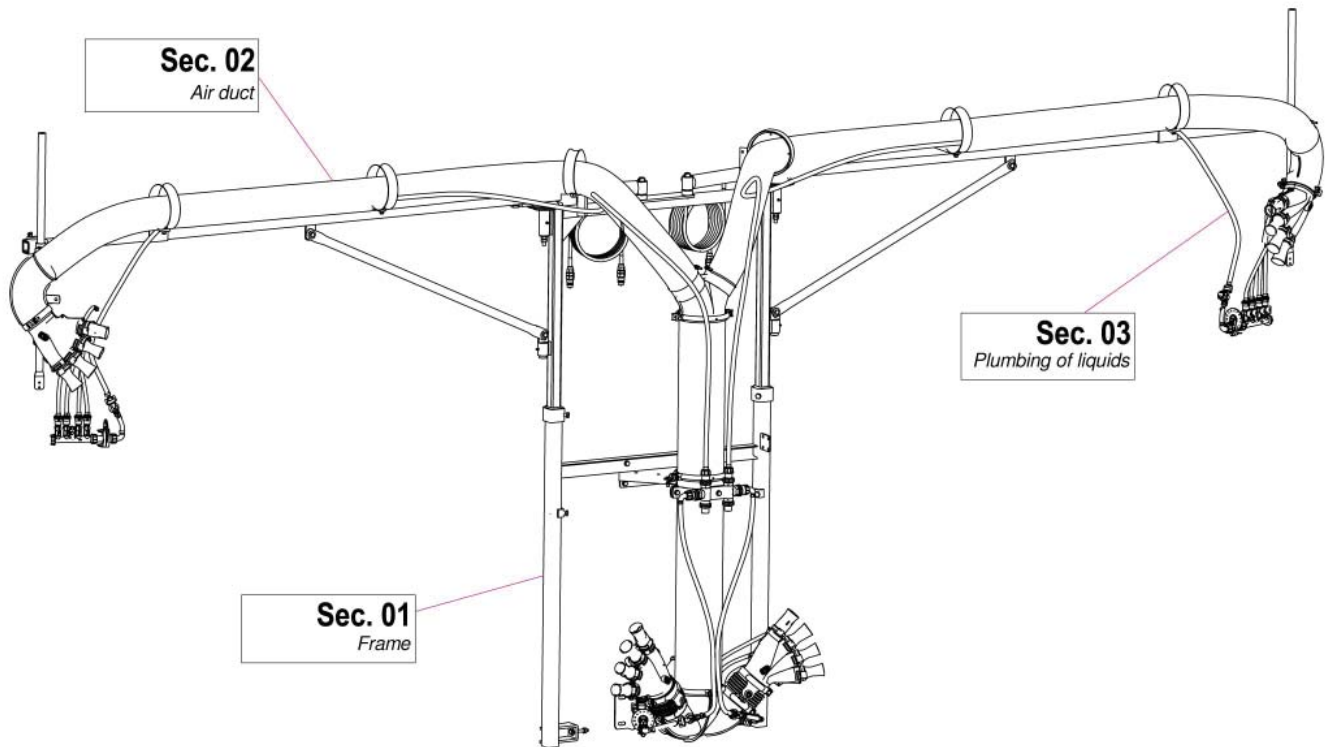

<u>SECTION</u>	<u>DESCRIPTION</u>	<u>PAGE</u>
1	Frame	1-2
2	Distribution Heads & Air Tubes	3-4
3	Liquid Hose & Fittings	5-6
4	Manifold & Shut-Off Valves	7
5	Dial-A-Rate	8

Sec. 01 - FRAME

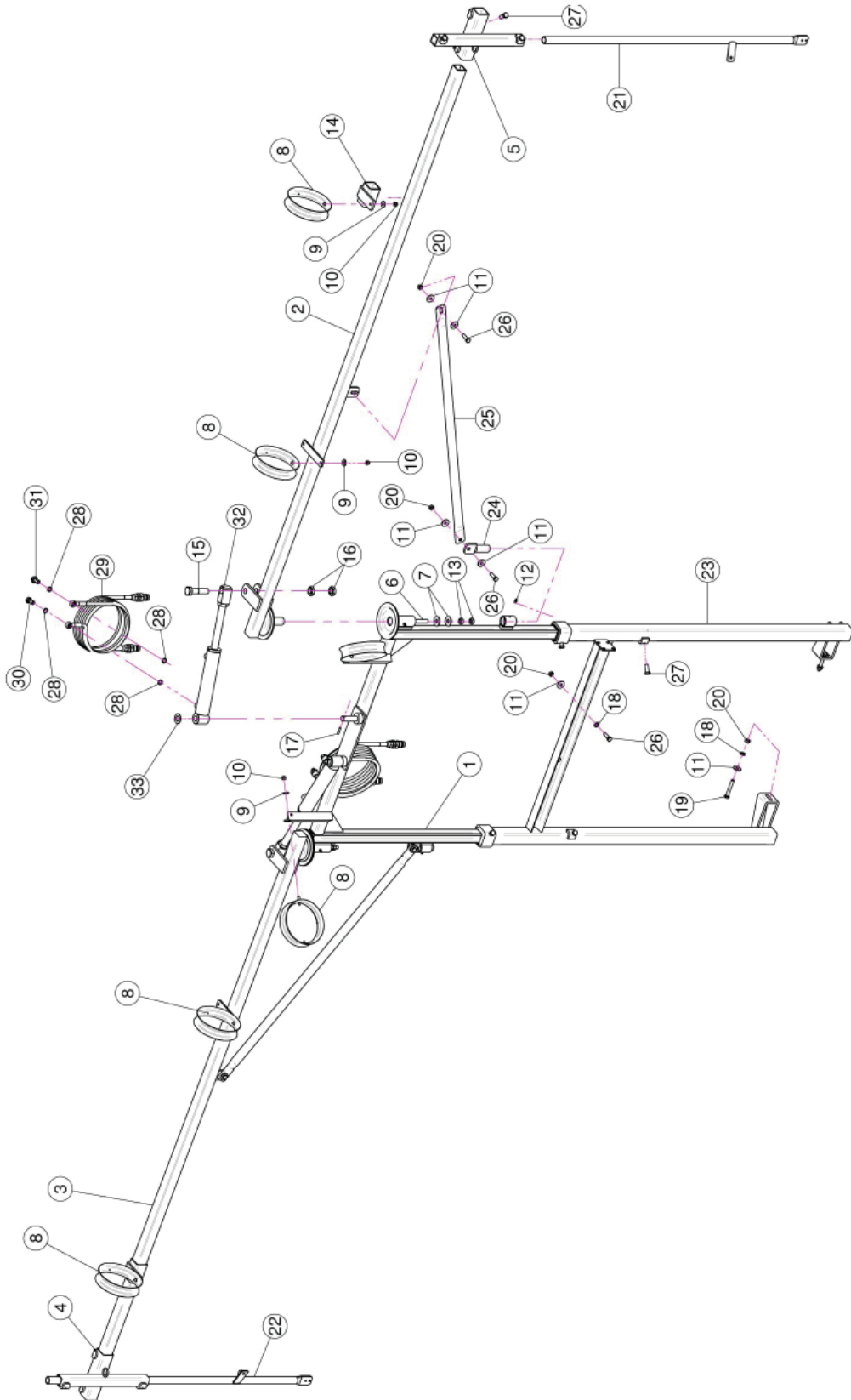

Sec. 01 - *FRAME*

<u>REF.</u>	<u>QTY.</u>	<u>PART NO.</u>	<u>DESCRIPTION</u>
1	1	21.043.001	Sliding Frame
2	1	21.045.102	Right Leg
3	1	21.046.102	Left Leg
4	1	20.874.100	Left Sliding Ring
5	1	20.873.100	Right Sliding Ring
6	2	BRF.012.010	Pipe M12 L=100
7	4	RP.012.036	Washer D12 x 36
8	6	20.227.000	Small Pipe Guide Ring
9	6	RP.008.024	Washer D.8 x 24
10	6	DA.008.0AG	Self Locking Nut M8
11	22	RP.010.030	Washer D.10 x 30 mm
12	4	ID.006.001	Greaser
13	4	D0.12.5587G	M12 Nut
14	2	21.047.000	Sliding Ring
15	2	TE.020.080	Screw TE M20 x 80
16	4	DO.20.5589G	Lower Nut M20
17	2	SE.006.030	Elastic Pin D.6 x 30
18	4	RP.010.000	Washer D.10
19	2	TE.010.070T	Screw TE M10 x 70
20	8	D0.10.5587G	Nut M10
21	1	20.685.600Z	Right Nozzle Fixing Arm
22	1	20.685.500Z	Left Nozzle Fixing Arm
23	1	21.049.401	Central Frame
24	2	21.116.000	Pin With Tie-Rod Attach
25	2	21.044.002	Tie Rod
26	6	TE.010.035T	Screw TE 10 x 35
27	12	TE.012.030T	Screw TE 12 x 30
28	8	02.472.000	Copper Washer
29	2	20.900.370	Oil Pipe For Jack L=3700
30	2	02.408.000	Jack Eye Right Union 1/4"
31	2	20.718.000	Flow Regulator
32	2	02.838.100C	Cylinder
33	2	RP.020.000	Washer D.20

Sec. 02 - DISTRIBUTION HEADS & AIR TUBES

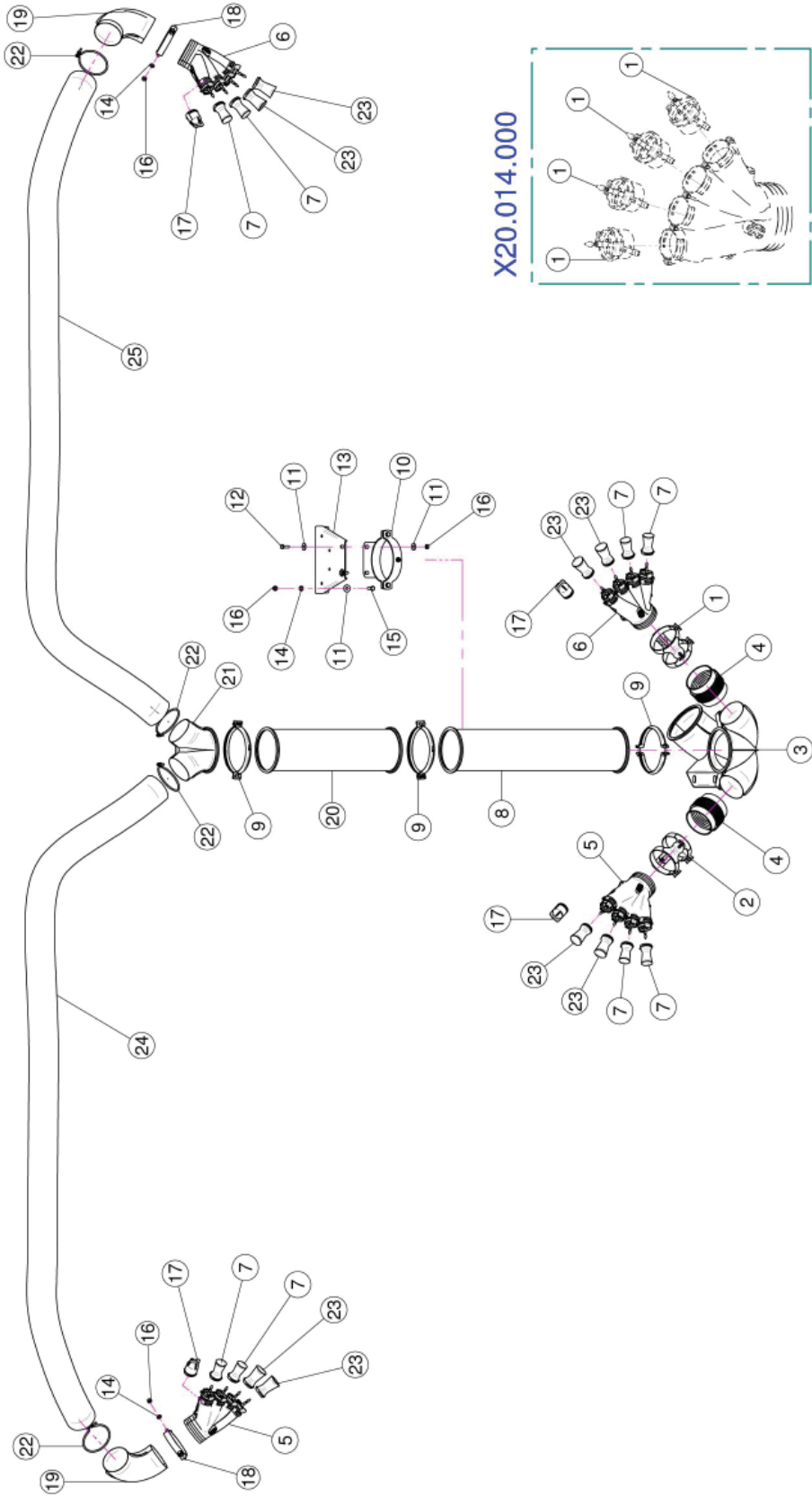

Sec. 02 - DISTRIBUTION HEADS & AIR TUBES

<u>REF.</u>	<u>QTY.</u>	<u>PART NO.</u>	<u>DESCRIPTION</u>
1	1	21.080.000	Right Clamp Ø 127
2	1	21.081.000	Left Clamp Ø 127
3	1	04.882.400	Lower Bend
4	2	02.021.000	Flexible Sleeve
5	2	20.014.000SX	Four Outlets
6	2	20.014.000DX	Four Outlets
7	8	00.006.050	Nozzle 6/50
8	1	02.189.000	Extension D.175 x 800
9	3	05.616.000	Pipe Clamp D.175
10	1	20.503.000	D.175 Clamp Heads Fixing
11	6	RP.010.030	Washer D.10 x 30 mm
12	2	TE.010.030T	Screw TE M10 x 30
13	1	40.208.001	Fixing Bracket
14	4	RP.010.000	Washer D.10
15	2	TE.010.035T	Screw TE 10 x 35
16	6	D0.10.5587G	Nut M10
17	4	02.127.000	Cap Nozzle Plug
18	2	00.127.001	Clamp D.127 With Screw 10 x 25
19	2	04.845.000	Elbow 90° D.120
20	1	02.188.000	Extension D.175 x 600
21	1	02.739.000	Body Head
22	4	F0.120.000	Clamp D.120
23	8	00.008.050	Nozzle 8/50
24	1	02.239.000	Hose D.120 L=3100 (Per Foot)
25	1	02.239.000	Hose D.120 L=3100 (Per Foot)
20.014.000			
1	4	20.016.01C	Venturi Body

Sec. 03 - LIQUID HOSE & FITTINGS

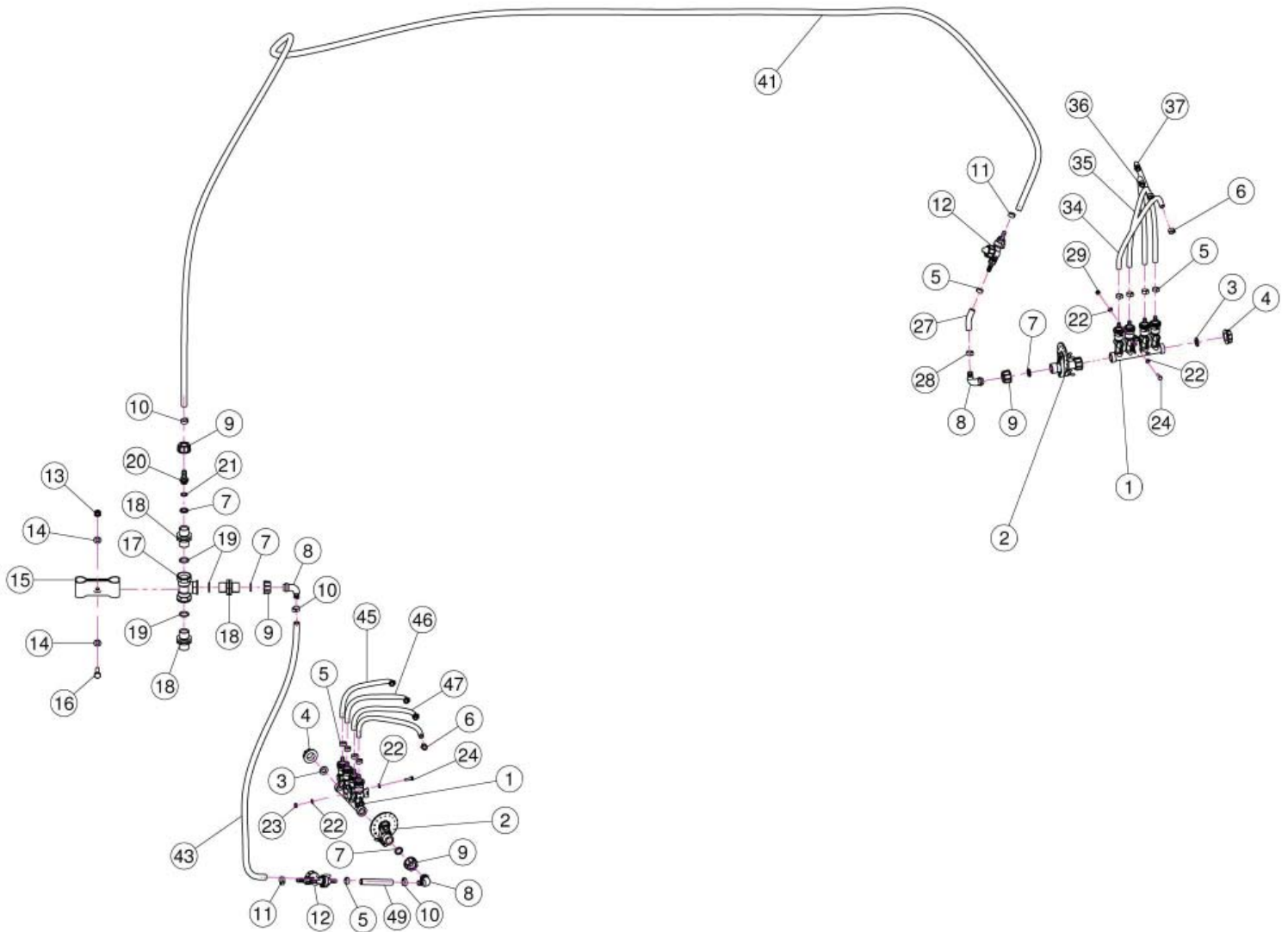

<u>REF.</u>	<u>QTY.</u>	<u>PART NO.</u>	<u>DESCRIPTION</u>
1	4	02.008.304C	4 Pipes Distributor
2	4	02.150.000	Rotation Disc Regulation
3	4	02.030.010	Gasket
4	4	02.182.000	Female 3/4" Cap
5	20	FC.013.5.015	Hose Clamp
6	16	FC.012.5.014	Hose Clamp
7	8	02.349.000	17 x 23 x 3 Flat Gasket

Sec. 03 - LIQUID HOSE & FITTINGS

<u>REF.</u>	<u>QTY.</u>	<u>PART NO.</u>	<u>DESCRIPTION</u>
8	6	00.055.046R	Curaved Union With R.H. D.14
9	8	00.055.045	3/4" fly Nut
10	6	FC.016.5.018	Hose Clamp 16.5 - 18
11	4	FC.015.5.017	Hose Clamp
12	4	00.226.05C	Complete Antidrop
13	1	DA.010.0BG	Self Locking Nut M10
14	2	RP.010.000	Washer D.10
15	1	02.999.000	T Union Fixing Bracket
16	1	TE.010.035T	Screw TE 10 x 35
17	2	02.396.000	Union 3/4" - 3/4" - 3/4" F.
18	6	02.380.000	Nipple 3/4"
19	6	OR.004.081	20.22 x 3.53 O-Ring Gasket
20	2	02.122.000	D.13 Union
21	2	OR.000.117	13.1 x 18.34 x 2.62 O-Ring Gasket
22	16	RP.006.000	Washer D.6
23	4	D0.06.5588G	Nut M6
24	8	TE.006.020T	Screw TE M6 x 20
25	2	02.217.000	Hose D.8 x 13 L=410 (Per Foot)
26	2	02.217.000	Hose D.8 x 13 L=310 (Per Foot)
27	2	02.213.000	Hose D.10 x 16 L=70 (Per Foot)
28	2	FC.014.5.016	Hose Clamp
29	4	D0.06.5588G	Nut M6
30	1	02.217.000	Hose D.8 x 13 L=200 (Per Foot)
31	1	02.217.000	Hose D.8 x 13 L=230 (Per Foot)
32	1	02.217.000	Hose D.8 x 13 L=260 (Per Foot)
33	1	02.217.000	Hose D.8 x 13 L=290 (Per Foot)
34	1	02.217.000	Hose D.8 x 13 L=200 (Per Foot)
35	1	02.217.000	Hose D.8 x 13 L=230 (Per Foot)
36	1	02.217.000	Hose D.8 x 13 L=260 (Per Foot)
37	1	02.217.000	Hose D.8 x 13 L=290 (Per Foot)
38	1	02.217.000	Hose D.8 x 13 L=250 (Per Foot)
39	1	02.217.000	Hose D.8 x 13 L=390 (Per Foot)
41	1	02.213.000	Hose D.10 x 16 L=2500 (Per Foot)
42	1	02.213.000	Hose D.10 x 16 L=2500 (Per Foot)
43	1	02.213.000	Hose D.10 x 16 L=100 (Per Foot)
44	1	02.213.000	Hose D.10 x 16 L=100 (Per Foot)
45	1	02.217.000	Hose D.8 x 13 L=410 (Per Foot)
46	1	02.217.000	Hose D.8 x 13 L=390 (Per Foot)
47	1	02.217.000	Hose D.8 x 13 L=330 (Per Foot)
48	1	02.213.000	Hose D.10 x 16 L=070 (Per Foot)
49	1	02.213.000	Hose D.10 x 16 L=070 (Per Foot)

Sec. 04 - MANIFOLD & SHUT-OFF VALVES

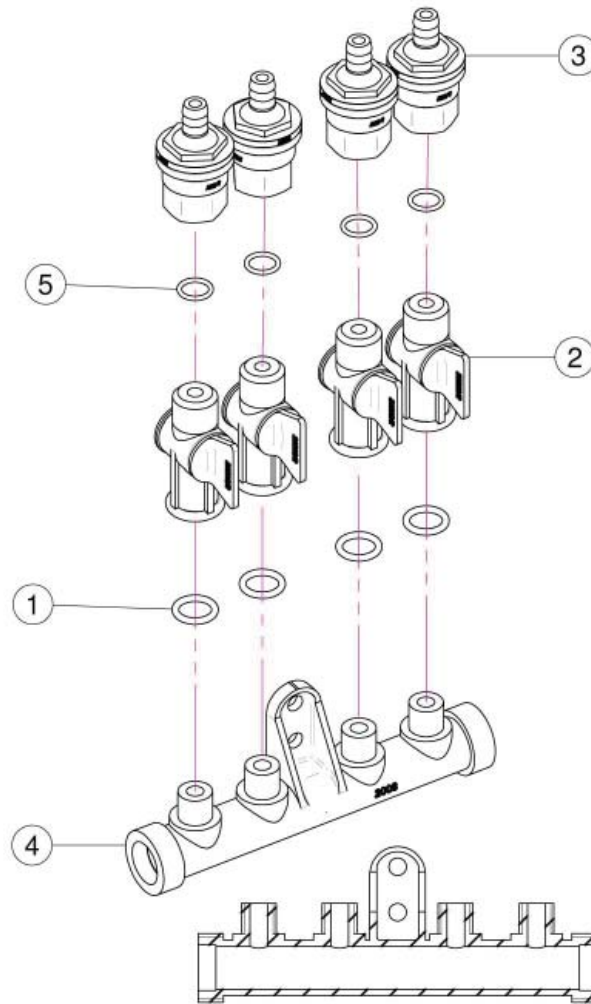

REF.	QTY.	PART NO.	DESCRIPTION
		02.008.304C	Complete Assembly
1	4	OR.000.117	13.1 x 18.34 x 2.62 O-Ring Gasket
2	4	20.202.100	Tap Assembly
3	4	00.227.01C	Anti-Drip Valve
4	1	02.008.000	Sprayheads Liquid Manifold
5	4	OR.002.043	10.82 x 14.38 x 1.78 Nbr 70 O-Ring Gasket

Sec. 05 - DIAL-A-RATE

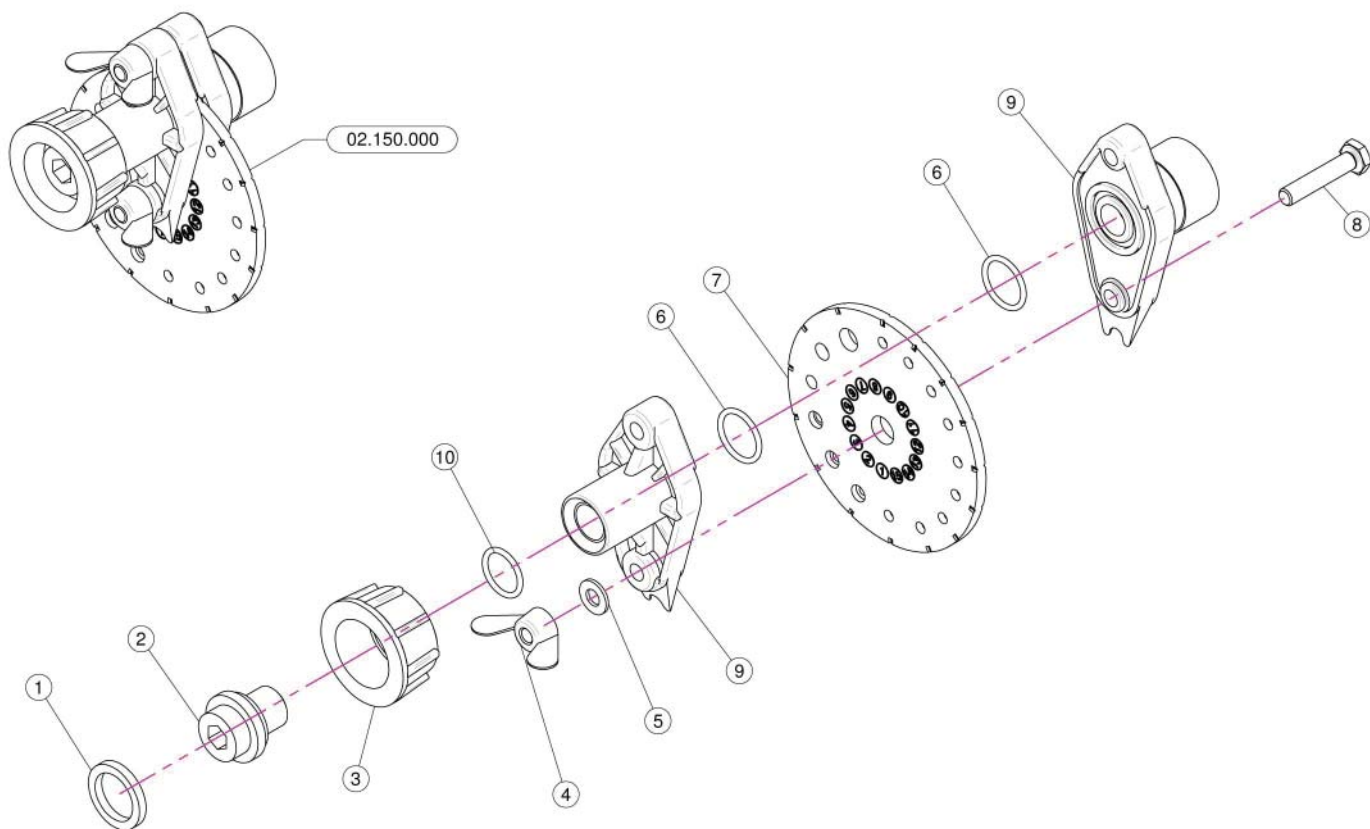

<u>REF.</u>	<u>QTY.</u>	<u>PART NO.</u>	<u>DESCRIPTION</u>
1	1	02.349.000	17 x 23 x 3 Flat Gasket
2	1	02.117.000	Adaptor Nipple
3	1	2002030	3/4" Fly Nut
4	2	DF.OTT.006	Wing Nut M6
5	2	RP.006.000I	INOX Washer D.6
6	2	OR1560178	D.15.6 x 1.78 O-Ring
7	1	02.148.000	Regulator Disc
8	2	TE.006.030I	INOX M6 x 30 Bolt
9	1	02.147.000	Regulator Body
10	1	OR1242178	O-Ring D.12.37 x 2.62