

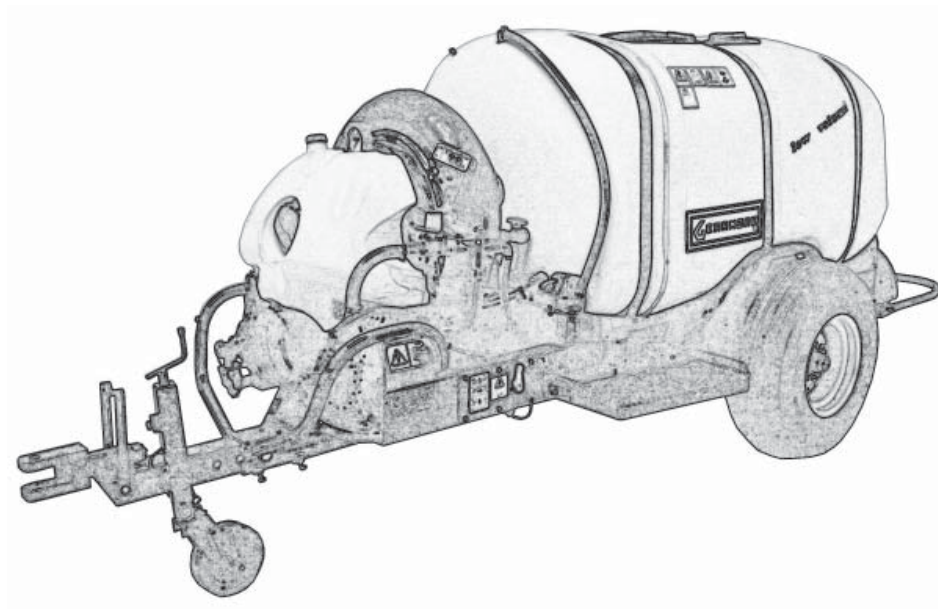

# VENTURI AIR SPRAYERS



## Parts Manual For Models T55S2-2000 & T55E2-2000 500 Gallon Capacity

June 2013

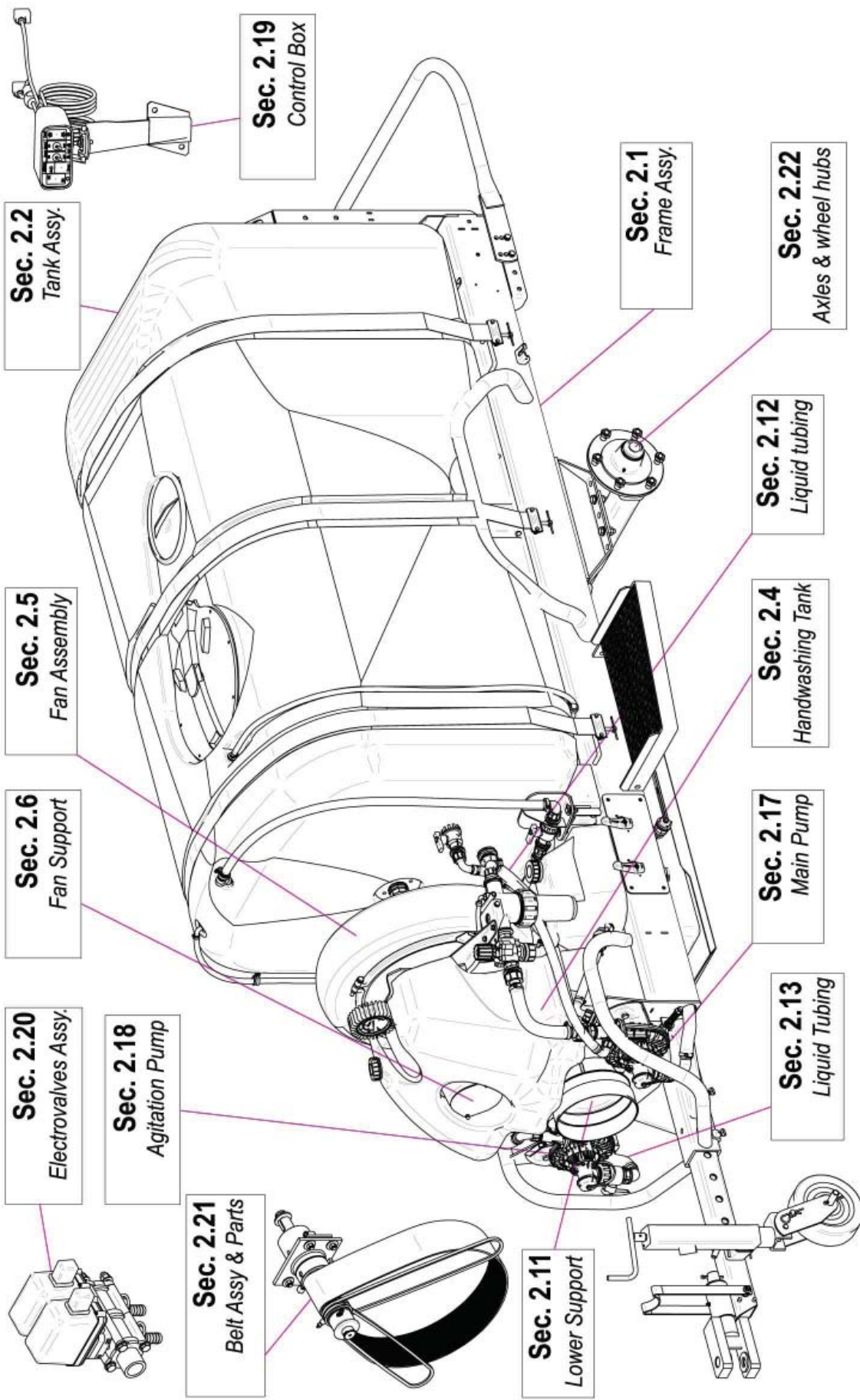

# TABLE OF CONTENTS

<u>SECTION</u>	<u>DESCRIPTION .....</u>	<u>PAGE</u>
<b>1</b>	<b>Introduction .....</b>	<b>1</b>
1.1	Purchaser's Responsibility .....	1
1.2	Serial Number Information .....	1
<b>2</b>	<b>Replacement Parts .....</b>	<b>2 - 39</b>
2.1	Frame Assembly.....	2-4
2.2	Tank Assembly.....	5-6
2.3	Tank Fittings & Cover .....	7-8
2.4	Hand Wash Tank .....	9
2.5	Fan Assembly .....	10
2.6	Fan Support & Belt Tensioner .....	11
2.7	Fan Support Breakdown.....	12-13
2.8	Belt Tension Roller.....	14
2.9	Lubrication Tubing.....	15
2.10	Main Pulley & Overrunning Clutch.....	16
2.11	Fan Support Hub Assy .....	17
2.12	Liquid Flow Path Manual Controls.....	18-20
2.13	Pumps & Routing.....	21-22
2.14	Pressure Regulator & 3 Way Valve.....	23
2.15	Suction Filter Assembly.....	24
2.16	Main Pump Breakdown.....	25-28
2.17	Agitation Pump Breakdown.....	29-32
2.18	Control Box 910208/T.....	33
2.19	Electro Valves.....	34-35
2.20	Pump & Fan Belts .....	36
2.21	Axle & Wheel Hubs .....	37
2.22	Tank Agitation Parts.....	38
2.23	Driveshaft .....	39
<b>3</b>	<b>Limited Warranty .....</b>	<b>40</b>

# 1 INTRODUCTION

This manual contains parts diagrams and replacement parts lists. Do not modify the equipment in any way. Unauthorized modification may impair the function and/or safety and could affect the life of the equipment.

It is the responsibility of the owner to make sure the machine is maintained properly, and that all parts are in working order.

Where replacement parts are necessary for periodic maintenance and servicing, genuine factory replacement parts ***MUST*** be used to restore your equipment to original specifications. The manufacturer will not be responsible for injuries or damages caused by use of unapproved parts and/or accessories.

The manufacturer reserves the right to make improvements to the machinery and parts at any time and at their discretion.

**OPERATOR ORIENTATION** - The directions left, right, front and rear, are as seen from the driver's seat and facing in the direction of travel.

## 1.1 PURCHASER'S RESPONSIBILITY

It is the responsibility of the purchaser and/or operator to.....

- Inspect the equipment and replace or repair any parts that are damaged or worn which under continued operation would cause damage, wear to other parts, or cause a safety hazard.
- Return the equipment or parts to the authorized dealer, from where it was purchased, for service or replacement of defective parts that are covered by warranty. (The factory may inspect equipment or parts before warranty claims are honored.)
- Payment of all costs incurred by the dealer for traveling to or transporting the equipment for warranty inspection and or claims.

## 1.2 MODEL / SERIAL NUMBER

NAME: \_\_\_\_\_

PURCHASED FROM: \_\_\_\_\_

DATE OF PURCHASE: \_\_\_\_\_

MODEL NUMBER: \_\_\_\_\_

SERIAL NUMBER: \_\_\_\_\_

# 2 REPLACEMENT PARTS

## 2.1 FRAME ASSEMBLY

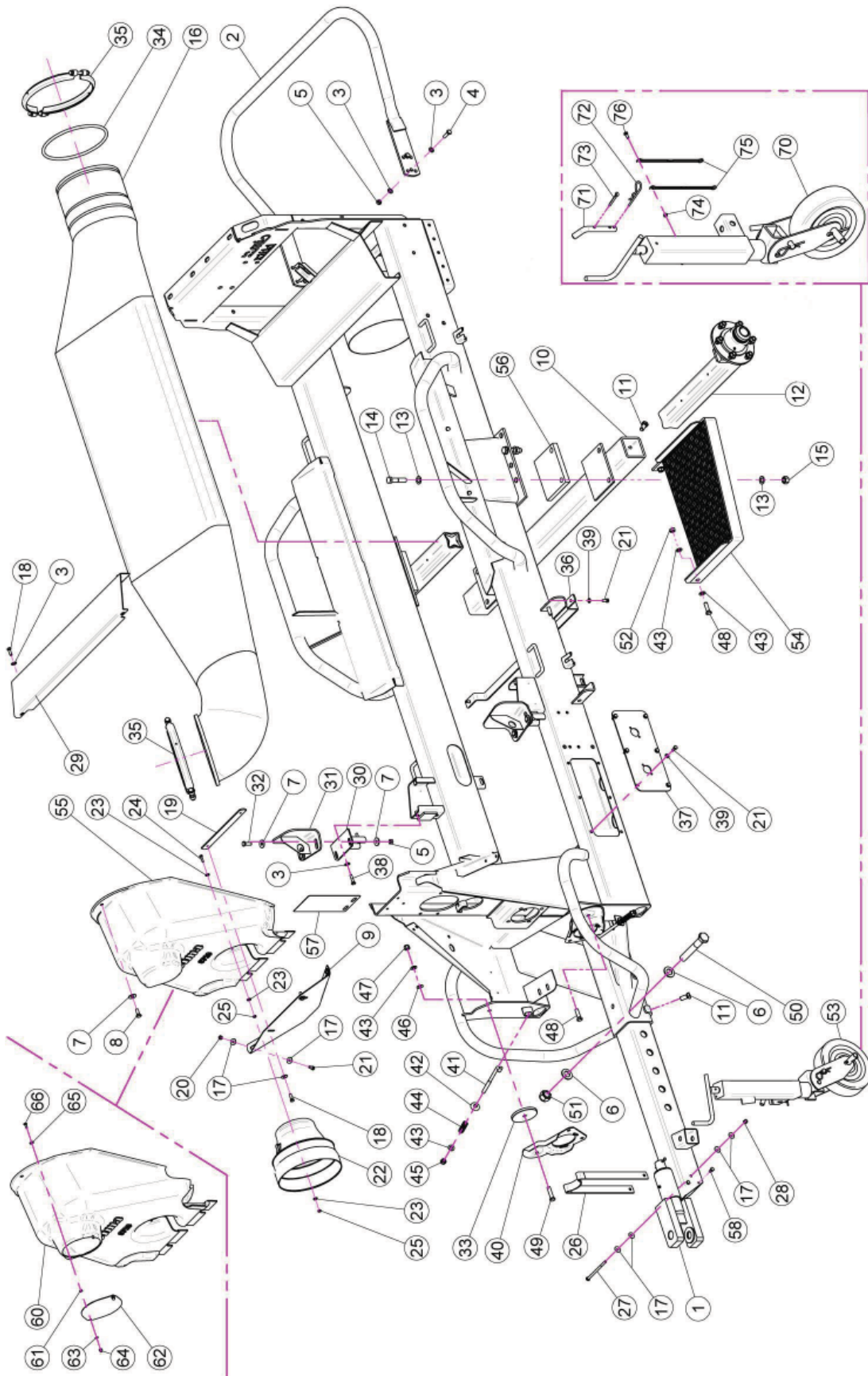

## 2.1 FRAME ASSEMBLY

<u>REF.</u>	<u>QTY.</u>	<u>PART NO.</u>	<u>DESCRIPTION</u>
<b>MAIN FRAME</b>			
1	1	05.862.103	Drawbar
2	1	40.146.100	Bumper
3	14	RP.010.000	Washer D.10
4	4	TE.010.035T	Screw TE 10 x 35
5	8	D0.10.5587G	Nut M10
6	2	RP.024.000	Washer D.24
7	9	RP.010.030	Washer D.10 x 30 mm
8	1	TE.010.025T	Screw TE 10 x 25T
9	1	20.531.000	Fixing Plate
10	1	50.035.000	Axle
11	6	TE.014.030T	Screw TE M14 x 30
12	2	05.903.100	Hub
13	8	RP.016.000	Washer D.16
14	4	TE.016.070	Screw TE M16 x 70
15	4	D0.16.5587G	Nut M16
16	1	05.997.100	Air Way Tunnel
17	10	RP.008.024	Washer D.8 x 24
18	4	TE.008.025T	Screw TE M8 x 25
19	1	20.532.000	Front Housing Blocking Plate
20	2	D0.08.5588G	Nut M8
21	10	TE.008.020T	Screw TE 8 x 20
22	1	02.441.000	Shaft Cone D.240
23	9	RD.006.000	Tab Washer D.6
24	3	TE.006.025T	Screw TE M6 x 25
25	6	D0.06.5588G	Nut M6
26	1	20.409.000	Shaft Support
27	1	TE.008.130	Screw M8 x 130
28	1	DA.008.0AG	Self Locking Nut M8
29	1	40.302.201	Plate Tank Support
30	2	50.280.000	Bracket
31	2	20.616.001	Bracket
32	4	TE.010.030T	Screw TE M10 x 30
33	1	20.533.100	Special Washer Ø 100 SP 10 mm
34	1	50.007.000	Gasket
35	2	05.813.010	Clamp D.275
36	1	50.329.000	Bracket
37	1	50.034.002	Protection 3-Way Valve
38	4	TE.008.035T	Screw TE M8 x 35
39	8	RP.008.000	Washer D.8
40	2	02.978.000SX	Bracket
41	2	21.005.000	Belt Stretcher For Pump
42	2	21.113.000	Washer D.12 x 36
43	8	RP.012.000	Washer D.12

## 2.1 FRAME ASSEMBLY

<b><u>REF.</u></b>	<b><u>QTY.</u></b>	<b><u>PART NO.</u></b>	<b><u>DESCRIPTION</u></b>
44	2	02.964.000	CD 32 Pump Spring
45	2	DOT.12.5587	M12 Brass Nut
46	2	MT.012.000	Washer D.12
47	2	DA.012.0AG	Self Locking Nut M12
48	3	TE.012.040T	Bolt TE M12 x 40
49	1	TE.012.050T	Screw M12 x 50T
50	1	TE.024.150	Screw TE M24 x 150
51	1	DA.024.0AG	Self Locking M24
52	2	D0.12.5588G	M12 6S Big Lead Nut 5588
53	1	05.727.400C	Extractable Wheel
54	1	50.079.101	Footboard
55	1	05.723.160	Front Housing For 2 Pumps
56	2	50.035.001B	Plate 140 x 20
57	1	50.355.000	Product Note Support

### **FAN GUARD**

60	1	05.723.060	Front Housing For 2 Pumps
61	2	D0.06.5589G	Nut M6
62	1	40.333.000	Fan Clutch Lid
63	2	RP.006.000	Washer D.6
64	2	DC.06.5721I	Nut DIN 1587 6 x 2-6-10
65	2	RD.006.000	Tab Washer D.6
66	2	TE.006.016T	Screw TE M6 x 16

### **TONGUE JACK**

70	1	05.727.400	Support Wheel
71	1	20.505.000	Pin Jack Stand
72	1	00.100.004	Split Pin D.4
73	1	CP.006.040I	Pin D.6 Lg.40
74	1	D0.06.5588G	Nut M6
75	2	21.183.000	Cap Stop
76	1	TE.006.016T	Screw TE M6 x 16

## 2.2 TANK ASSEMBLY

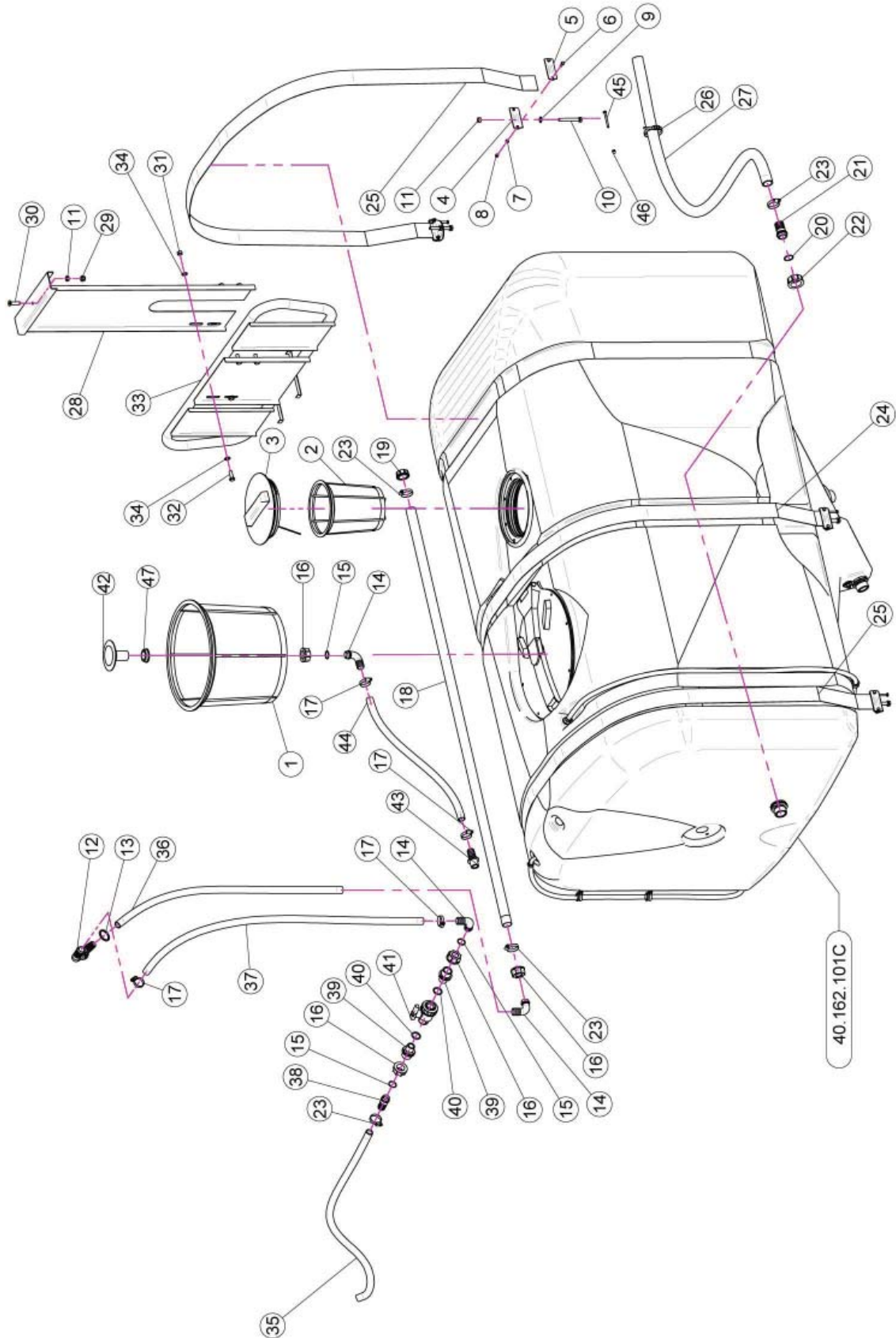



## 2.2 TANK ASSEMBLY

<u>REF.</u>	<u>QTY.</u>	<u>PART NO.</u>	<u>DESCRIPTION</u>
1	1	02.404.100	Basket Filter 400 x 330
2	1	02.298.000	Basket Filter D.204
3	1	02.476.100	Threaded Lid D.255 With Rope
4	6	20.512.000	Bracket
5	6	20.513.000	Shaped Plate
6	12	TE.006.020T	Screw TE M6 x 20
7	12	RP.006.000	Washer D.6
8	12	DA.006.0AG	Self Locking Nut High M6
9	6	RP.010.000	Washer D.10
10	6	TE.010.080T	M10 x 80 Bolt
11	7	DOT.10.5587	M10 Brass Nut
12	1	24.031.000	Pipe Fitting - Back Nut
13	1	02.066.000	Gasket D.33 x 45
14	3	00.055.037	D.25 Hosetail
15	3	OR.000.132	23.81 x 2.62 O-Ring Gasket
16	4	00.055.24.2	1" Fly Nut
17	4	F0.023.035I	Stainless Steel Clip
18	1	20.608.000	Perforated Hose 1" L=1700
19	1	TF.001.000	Packing
20	1	OR.003.112	O-Ring D.28.24 x 2.62
21	1	00.058.028	Straight Hose R.H. D.30
22	1	00.058.006	1" 1/4 Fly Nut
23	5	F0.025.040I	Stainless Steel Clip
24	1	02.481.280	Nylon Band 60 mm L=2800
25	2	02.481.325	Nylon Band 60 mm L=3250
26	3	02.355.000	Nylon Assembly Clamp
27	1	02.238.000	Hose D.30 L=1700 (Per Foot)
28	1	20.646.000	Bracket Fixing Breakwater
29	1	DA.010.0BGI	Self Locking Nut M10
30	1	TSCE.010.040TI	Screw M10 x 40
31	4	D0.10.5587GI	Nut M10
32	4	TE.010.030I	INOX M10 x 30 Screw
33	1	20.609.000	Breakwater
34	8	RP.010.00I	Washer D.10 INOX
35	1	20.770.000	Hose D.25 L=1000 (Per Foot)
36	1	20.770.000	Hose D.19 x 25 L=900 (Per Foot)
37	1	20.770.000	Hose D.25 L=1000 (Per Foot)
38	1	00.055.021	Straight Hose R.H. D.25
39	2	02.293.000	1" M - 3/4" M Reducer Nipple
40	2	OR.000.134	O-Ring D.25.8 x 3.53
41	1	02.395.000	Valve 3/4" GAS F.F. Ball
42	1	00.055.034	Nipple 1" / 1" GAS
43	1	00.373.000	1" GAS Sleeve
44	1	00.131.000	1" Vortex Damper Drive
45	1	20.793.000	Hosetail R.H. D.25 3/4" GAS M.
46	1	20.809.000	Hose D.25 L=2100 (Per Foot)
47	6	TE.006.060I	INOX M6 x 60 TE Screw
48	6	DC.06.5721I	Nut DIN 1587 6 x 1-6-10

## 2.3 TANK FITTINGS & COVERS

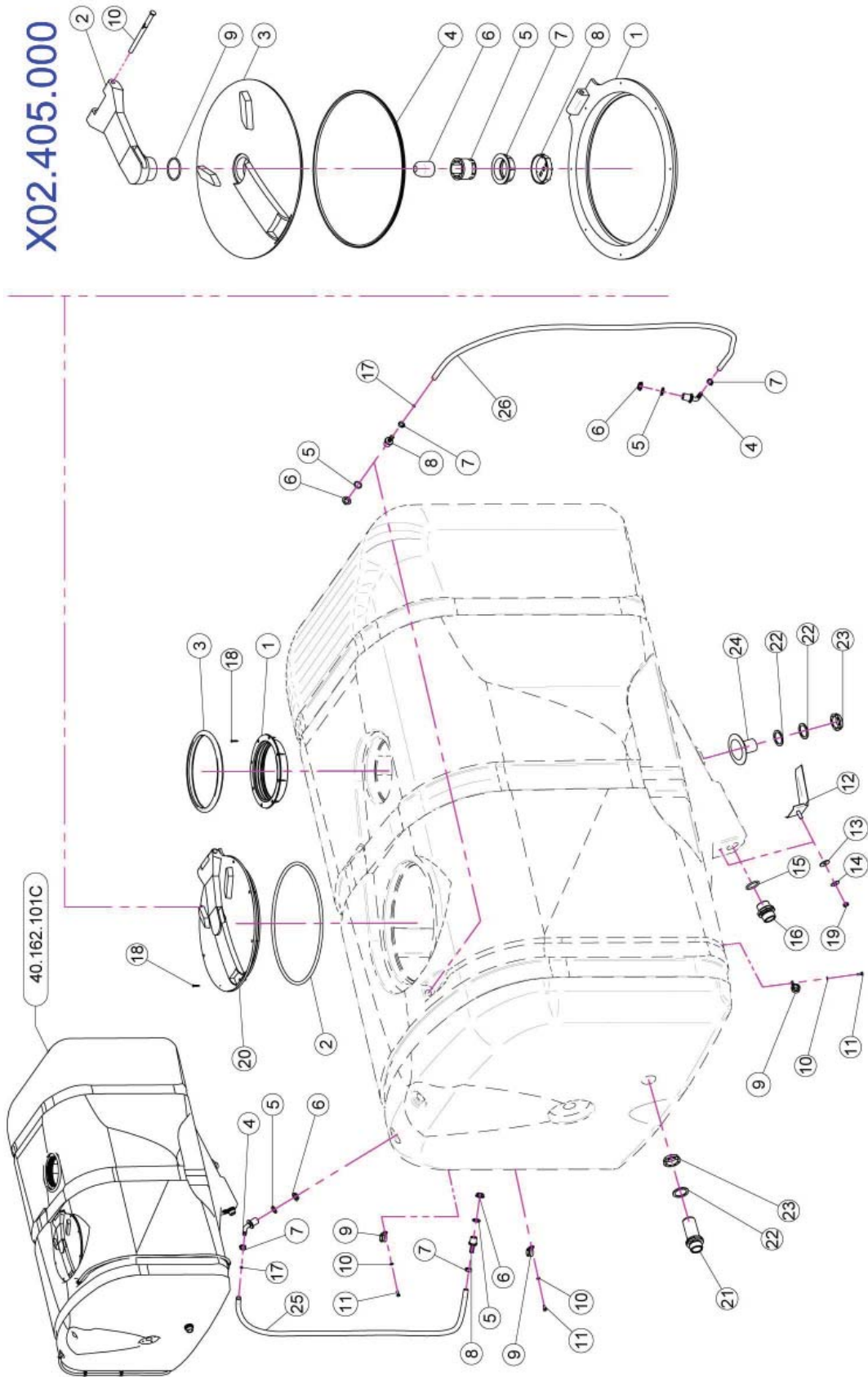

## 2.3 TANK FITTINGS & COVERS

<u>REF.</u>	<u>QTY.</u>	<u>PART NO.</u>	<u>DESCRIPTION</u>
1	1	02.477.000	Threaded Ring D.255
2	1	02.405.000.L	Gasket
3	1	02.477.000.A	Threaded Ring Gasket D.255
4	2	02.457.000	Hosetail D.13 90° M. 1/2"
5	4	OR.004.081	20.22 x 3.53 O-Ring Gasket
6	4	02.458.000	Lock Ring 1/2"
7	4	FC.016.5.018	Hose Clamp 16.5 - 18
8	2	02.482.000	Hosetail Male Threaded 1/2"
9	3	FG.018.000	Sticker
10	3	RP.006.000	Washer D.6
11	3	TE.006.016T	Screw TE M6 x 16
12	1	20.498.002	Stainless Steel Anti-Vortex
13	1	20.436.000	Special Garnishing For Anti-Whirl
14	1	RP.010.030	Washer D.10 x 30 mm
15	1	OR.006.162	40 x 5 O-Ring Gasket
16	1	00.345.010	Nipple 1" 1/4 + 1" 1/4 GAS
17	2	02.478.000	Red Floating Ball D.8.5
18	16	TAS.04.2.025I	Self Threaded Screw 4.2 x 25
19	1	DOT.10.5587	M10 Brass Nut
20	1	02.405.000	Hinged Tank Lid
21	1	00.345.000	Nipple 1" 1/4 + 1" 1/4 GAS
22	3	02.033.000	Gasket
23	2	00.543.000	Nut 1" 1/4 GAS
24	1	00.130.000	1" 1/4 Vortex Damper Drive
25	1	02.378.000	Hose Vitre O.D. 12 x 16 L=900 (Per Foot)
26	1	02.378.000	Hose Vitre O.D. 12 x 16 L=1800 (Per Foot)

### 02.405.000 MAIN LID ASSEMBLY

1	1	02.405.000.B	Base Ring
2	1	02.405.001	Arm
3	1	02.405.000.A	Gripping Plate
4	1	02.405.002	Shaped Gasket
5	1	20.787.000.G	Breather Valve
6	1	20.787.000.F	Floating Ball
7	1	20.787.000.H	Ring Nut
8	1	20.787.000.I	Cap For Breather Valve
9	1	OR.000.512	51 x 3.5 O-Ring Gasket
10	1	20.787.000.D	Pin

## 2.4 HAND WASH TANK

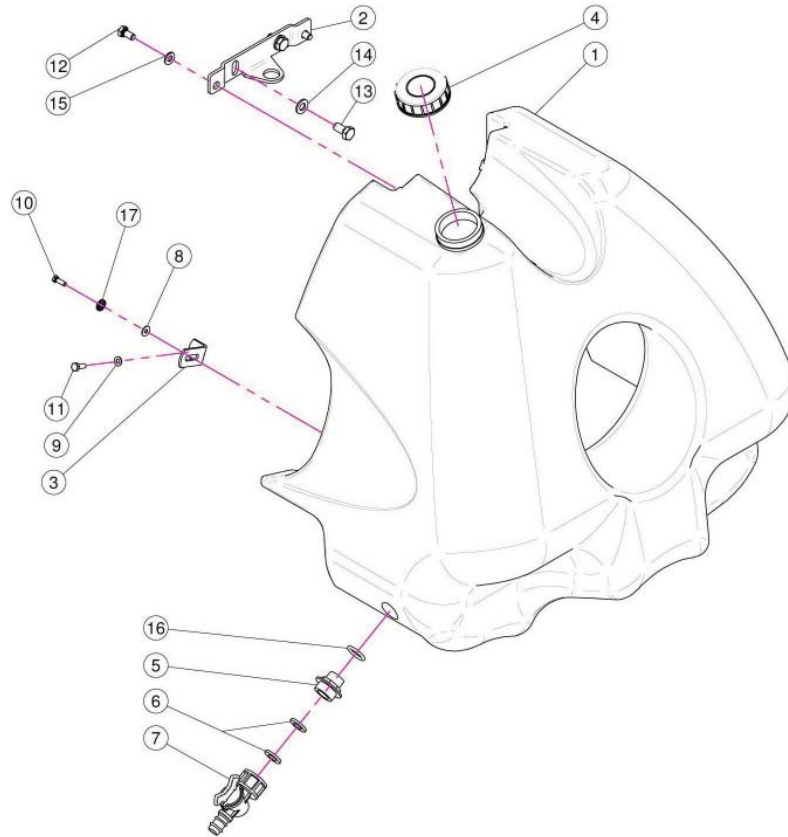

<u>REF.</u>	<u>QTY.</u>	<u>PART NO.</u>	<u>DESCRIPTION</u>
1	1	40.322.000	Hand Washing Tank
2	1	40.323.000	Fixing Bracket
3	2	40.324.100	Bracket
4	1	02.460.000	Female Threaded Tank Lid
5	1	00.055.044	Nipple 1/2" - 3/4" GAS
6	2	02.030.010	Gasket
7	1	02.497.000	3/4" Female Valve
8	2	RP.005.015I	Washer D.5 x 15
9	2	RP.006.000	Washer D.6
10	2	TE.005.016I	Screw TE M5 x 16
11	2	TE.006.016T	Screw TE M6 x 16
12	2	TE.008.016T	Screw TE M8 x 16
13	2	TE.010.020T	Screw TE M10 x 20
14	2	RP.010.000	Washer D.10
15	2	RP.008.000	Washer D.8
16	1	OR.004.081	20.22 x 3.53 O-Ring Gasket
17	2	RD.006.000	Tab Washer D.6

## 2.5 FAN ASSEMBLY

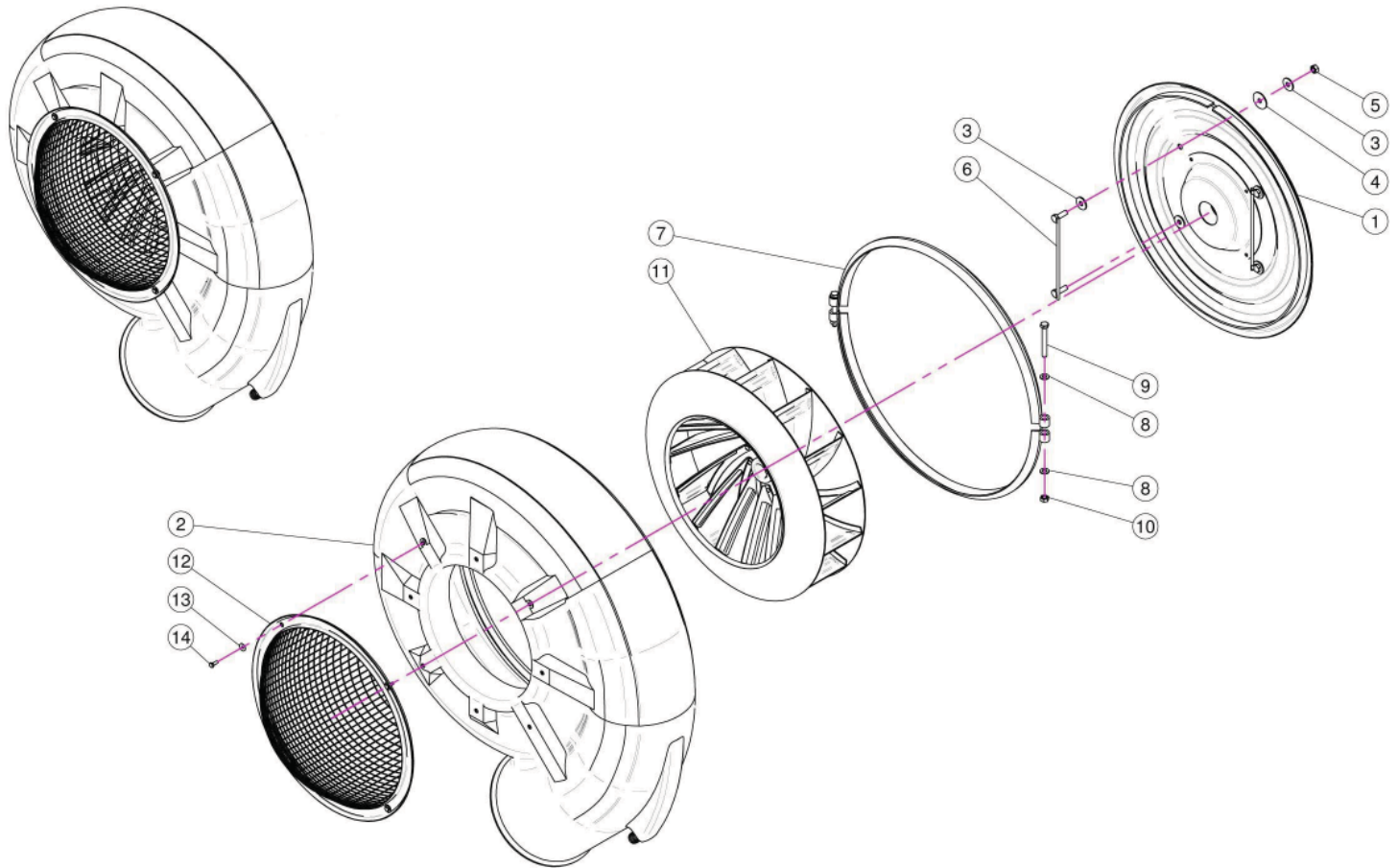

<u>REF.</u>	<u>QTY.</u>	<u>PART NO.</u>	<u>DESCRIPTION</u>
1	1	50.172.000	Fan 55 Cover
2	1	05.011.600	55 Fan Housing
3	8	RP.010.030	Washer D.10 x 30 mm
4	4	RP.010.040	Washer D.10 x 40
5	4	D0.10.5587G	Nut M10
6	2	20.088.000	Back Cover Bracket
7	1	50.004.000Z	D.610 Clamp For Female Screw
8	4	RP.010.000	Washer D.10
9	2	TE.010.080T	Bolt M10 x 80
10	2	DOT.10.5587	M10 Brass Nut
11	1	50.012.000	Fan 550
12	1	05.654.100	Fan Convex Net Protection
13	4	RP.006.018	Washer D.6 x 18
14	4	TE.006.016T	Screw TE M6 x 16

## 2.6 FAN SUPPORT & BELT TENSIONER

### "S" MODEL - SUPER

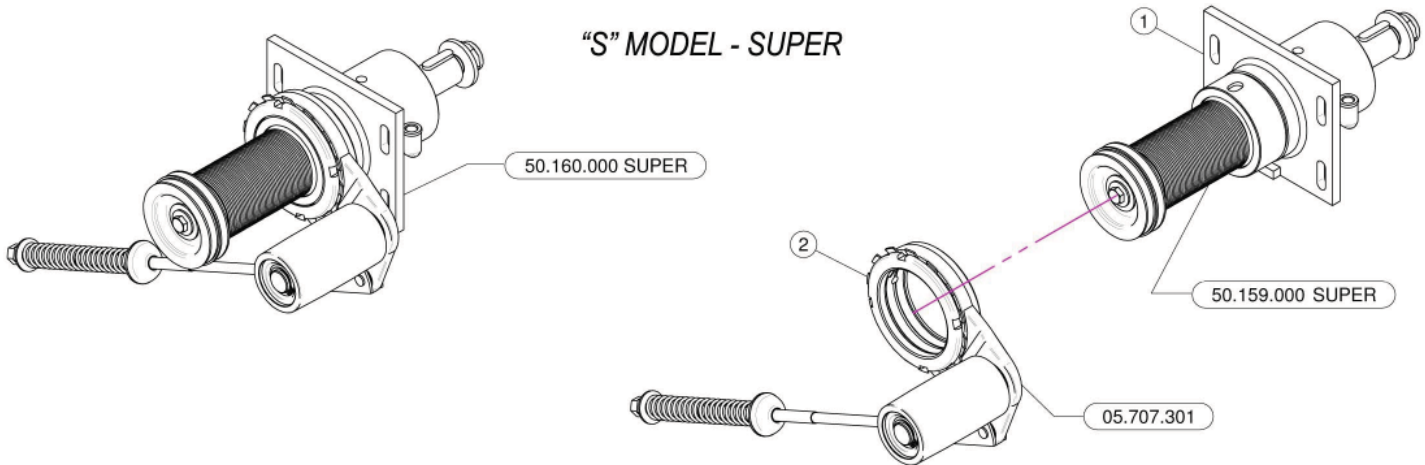

### "E" MODEL - EXTRA

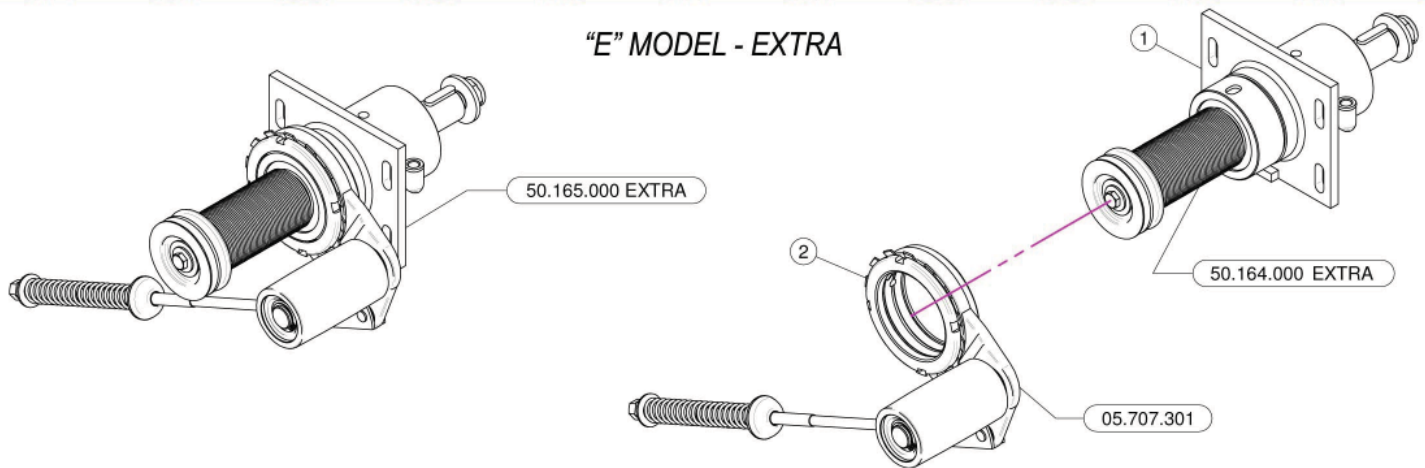

## 50.160.000 Super

<u>REF.</u>	<u>QTY.</u>	<u>PART NO.</u>	<u>DESCRIPTION</u>
1	1	50.159.000	Fan Support With Shaft - Pul D.70 No Disengagement
2	1	05.707.301	Automatic Belt Stretcher

## 50.165.000 Extra

1	1	50.164.000	Fan Support With Shaft - Pul D.66 No Disengagement
2	1	05.707.301	Automatic Belt Stretcher

## 2.7 FAN SUPPORT BREAKDOWN

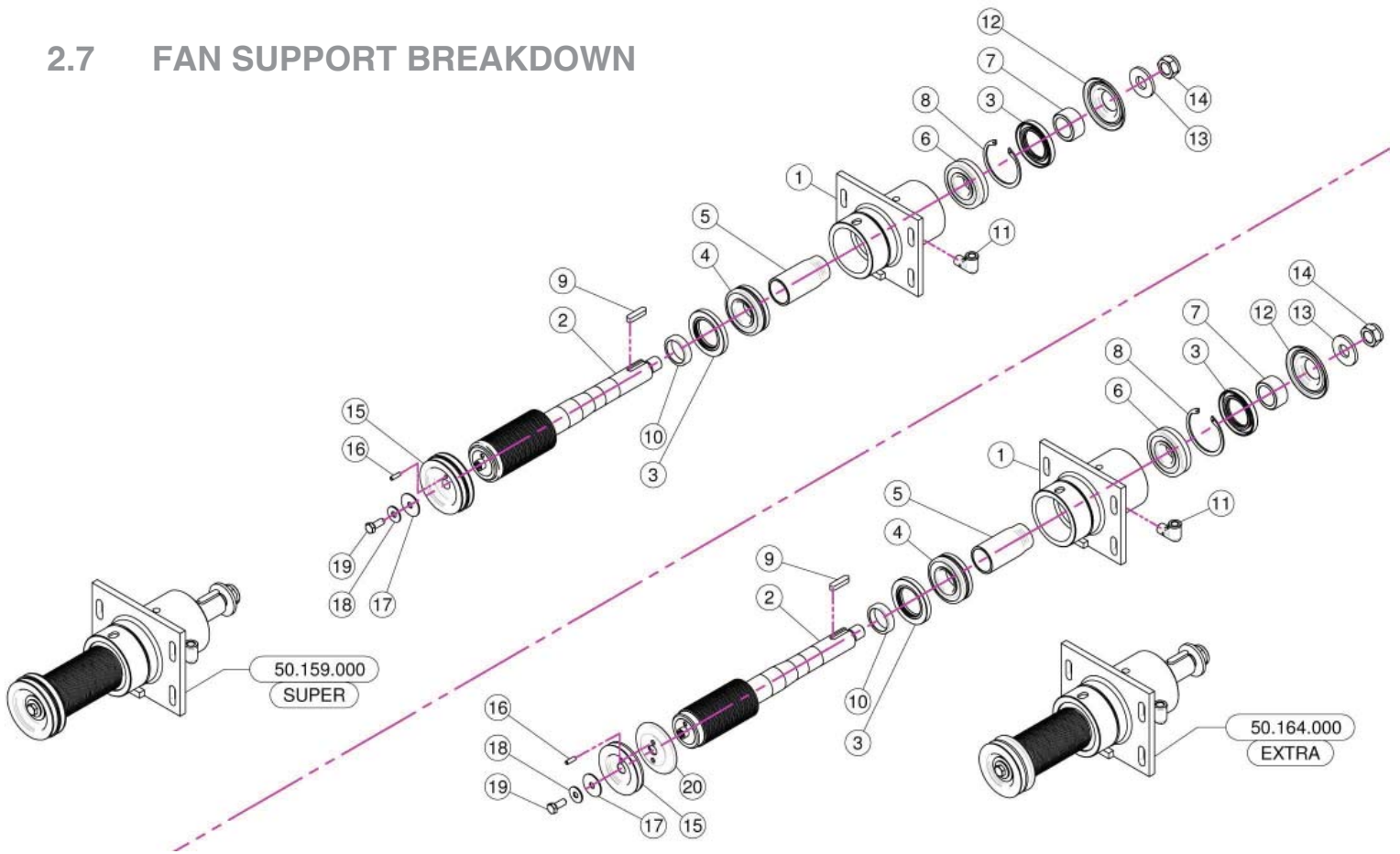

### 50.159.000 Super

<u>REF.</u>	<u>QTY.</u>	<u>PART NO.</u>	<u>DESCRIPTION</u>
1	1	50.110.000	Nude Fan Support
2	1	50.119.070	Shaft
3	2	BASL.50.80.10	Viton Lip Seals -IEL (50-80-10)
4	1	K0.022.208	Roller Bearing 22-208
5	1	50.112.000	Spacer
6	1	K0.021.307	Toller Bearing 21-307
7	1	50.113.000	Spacer
8	1	10.080.000	Internal D.80 Circlip
9	1	L.10.08.40	Feather Key 10 x 8 x 40
10	1	50.114.000	Spacer
11	1	20.789.000	Male/Femal 90° Elbow
12	1	50.115.000	Dust Cover
13	1	20.820.000	Washer
14	1	DA.022.0BF	Self-Locking Nut M22 x 1.5
15	1	05.896.000	Pulley For Pump D.99.5/D.95.5 (2 x 3V)
16	1	SE.006.020	Spring Pin D.6 x 20
17	1	RP.010.040	Washer D.10 x 40
18	1	RP.010.028	Washer D.10 x 28
19	1	TE.010.025FT	Bolt TE M10 x 25

## 2.7 FAN SUPPORT BREAKDOWN

### 50.164.000 Extra

<u>REF.</u>	<u>QTY.</u>	<u>PART NO.</u>	<u>DESCRIPTION</u>
1	1	50.110.000	Nude Fan Support
2	1	50.119.066	Shaft
3	2	BASL.50.80.10	Viton Lip Seals -IEL (50-80-10)
4	1	K0.022.208	Roller Bearing 22-208
5	1	50.112.000	Spacer
6	1	K0.021.307	Roller Bearing 21-307
7	1	50.113.000	Spacer
8	1	I0.080.000	Internal D.80 Circlip
9	1	L.10.08.40	Feather Key 10 x 8 x 40
10	1	50.114.000	Spacer
11	1	20.789.000	Male/Female 90° Elbow
12	1	50.115.000	Dust Cover
13	1	20.820.000	Washer
14	1	DA.022.0BF	Self-Locking Nut M22 x 1.5
15	1	05.816.000	Pulley For Pump D.88 (1 x 3V)
16	1	SE.006.020	Spring Pin D.6 x 20
17	1	RP.010.040	Washer D.10 x 40
18	1	RP.010.028	Washer D.10 x 28
19	1	TE.010.025FT	Bolt TE M10 x 25
20	1	02.723.000A	Semi Pulley D.88



## 2.8 BELT TENSION ROLLER

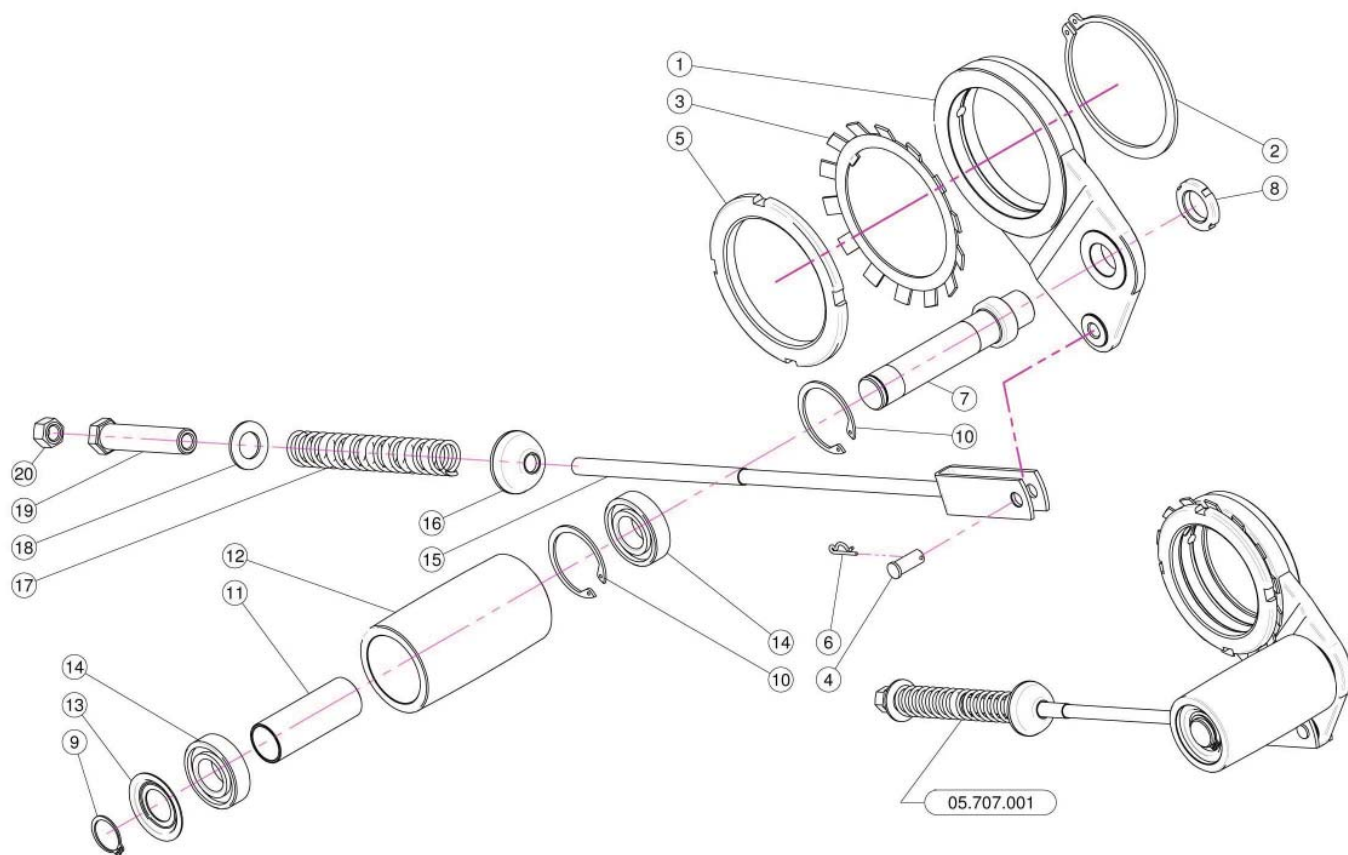

<b>REF.</b>	<b>QTY.</b>	<b>PART NO.</b>	<b>DESCRIPTION</b>
1	1	05.696.000	Idler Support
2	1	E0.100.000	External D.100 Circlip
3	1	MB.020.000	Tooth Lock Washer
4	1	04.593.000	Pin
5	1	05.704.000	Register Nut
6	1	00.100.002	Clip
7	1	05.697.000	Pivot
8	1	KM.005.000	Nut KM5
9	1	E0.025.000	External D.25 Circlip
10	2	I0.052.000	Internal D.52 Circlip
11	1	05.631.101	Spacer
12	1	05.630.000	Roller
13	1	04.585.000	Anti-Dust Cover
14	2	K6.205.2RS	Roller Bearing 6205-2RS
15	1	05.653.000	Belt Stretcher Fork
16	1	20.260.000	Special Washer D.12
17	1	05.647.100	Spring
18	1	RP.019.000	Washer D.19
19	1	04.583.000	Special Screw
20	1	D0.12.5587G	M12 Nut

## 2.9 LUBRICATION TUBING

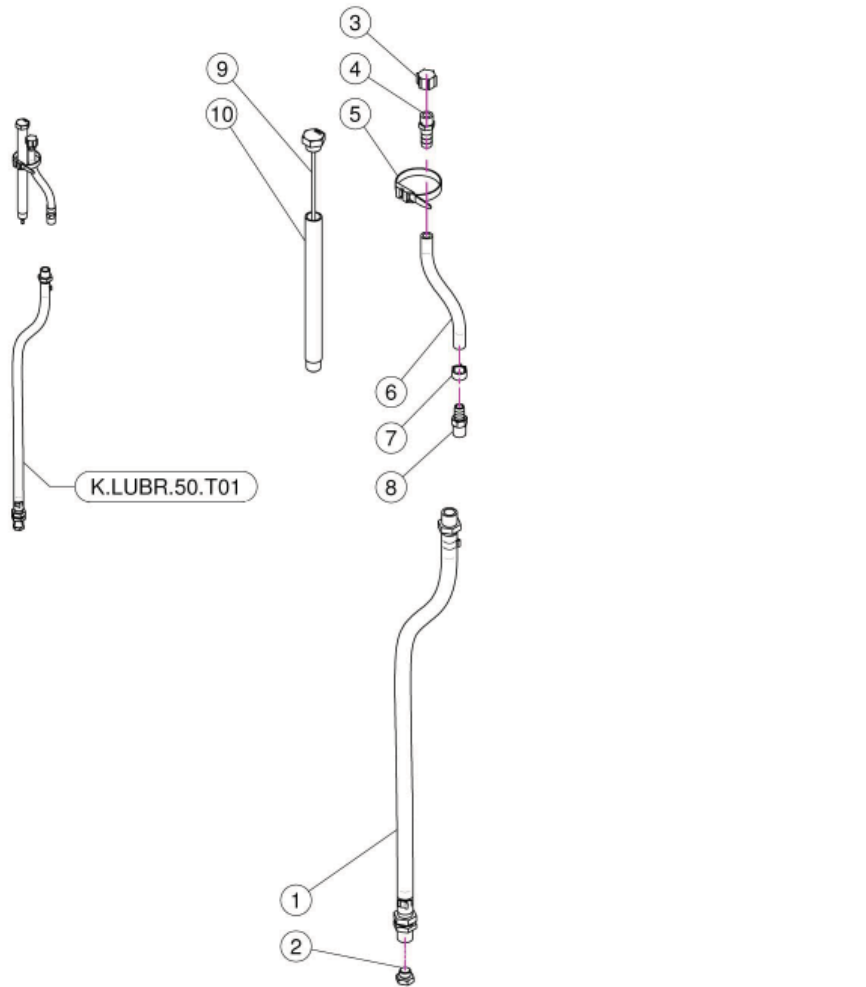

<u>REF.</u>	<u>QTY.</u>	<u>PART NO.</u>	<u>DESCRIPTION</u>
1	1	20.790.000	Drain Pipe 3/8"
2	1	40.266.000	Oil Exhaust Plug
3	1	02.013.000	Plug G1/4"
4	1	00.414.100	Straight Hose D.11 1/4" With Bleed
5	1	02.355.000	Nylon Assembly Clamp
6	1	02.217.000	Hose D.8 x 13 L=250 (Per Foot)
7	1	FC.014.5.016	Hose Clamp
8	1	20.792.000	Straight Hose D.11 G 1/4" For Breather
9	1	40.269.000	Filling Plug With Dipstick L=215
10	1	40.272.000	Filling Pipe L=201

## 2.10 MAIN PULLEY & OVERRUNNING CLUTCH

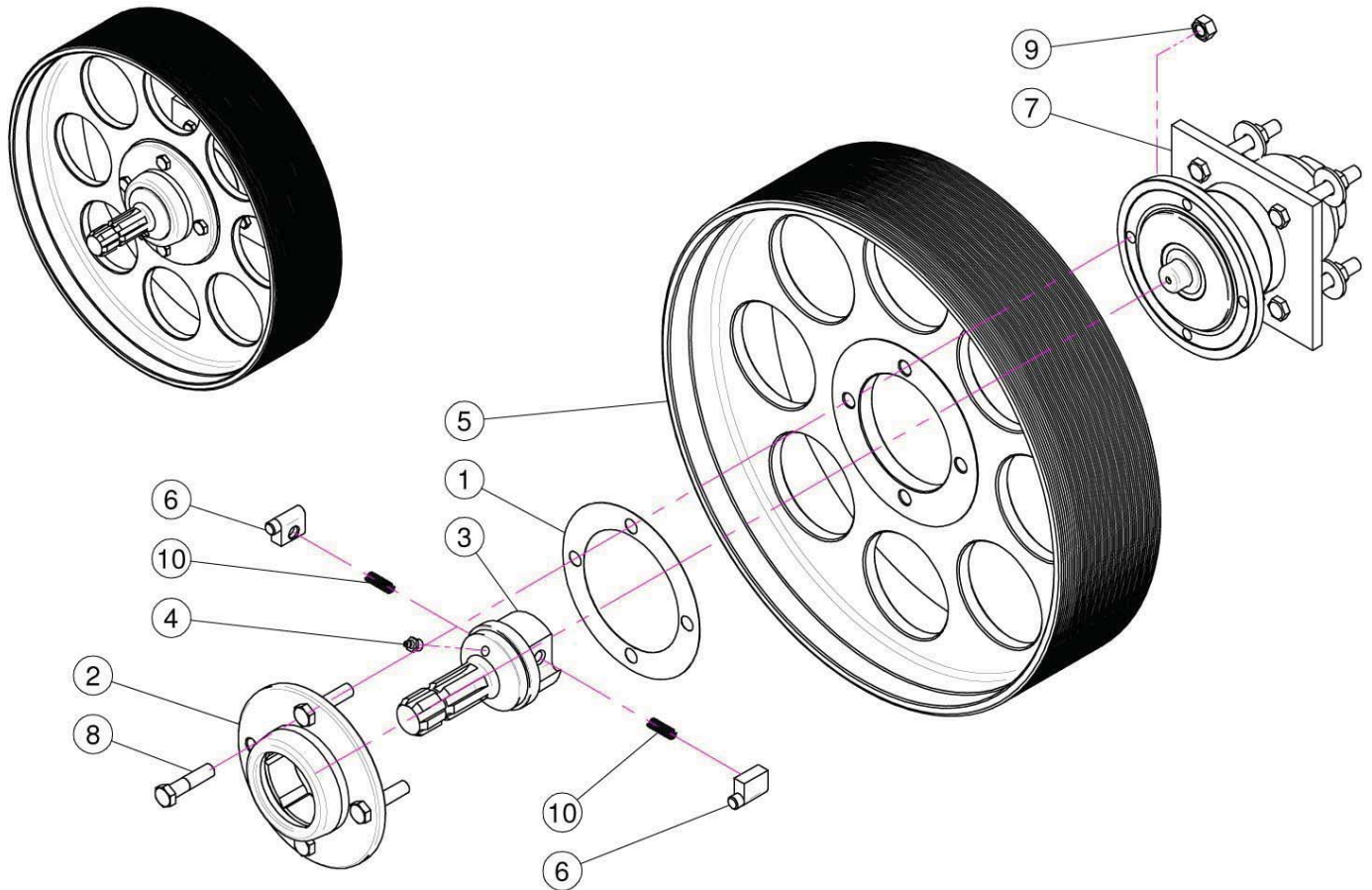

<u>REF.</u>	<u>QTY.</u>	<u>PART NO.</u>	<u>DESCRIPTION</u>
1	1	04.719.000	Gasket
2	1	04.066.000	Body
3	1	03.701.000	Rotor
4	1	ID.010.001	Grease Nipple
5	1	00.480.J50	Pulley Diameter 480 J 50
6	2	02.502.002	Pin
7	1	05.632.01C	Clutch
8	4	TE.012.050F	Bolt M12 x 50
9	4	DO.12.5587F	Nut M12 PG 5587F
10	2	02.502.001	Spring

## 2.11 FAN SUPPORT HUB ASSEMBLY

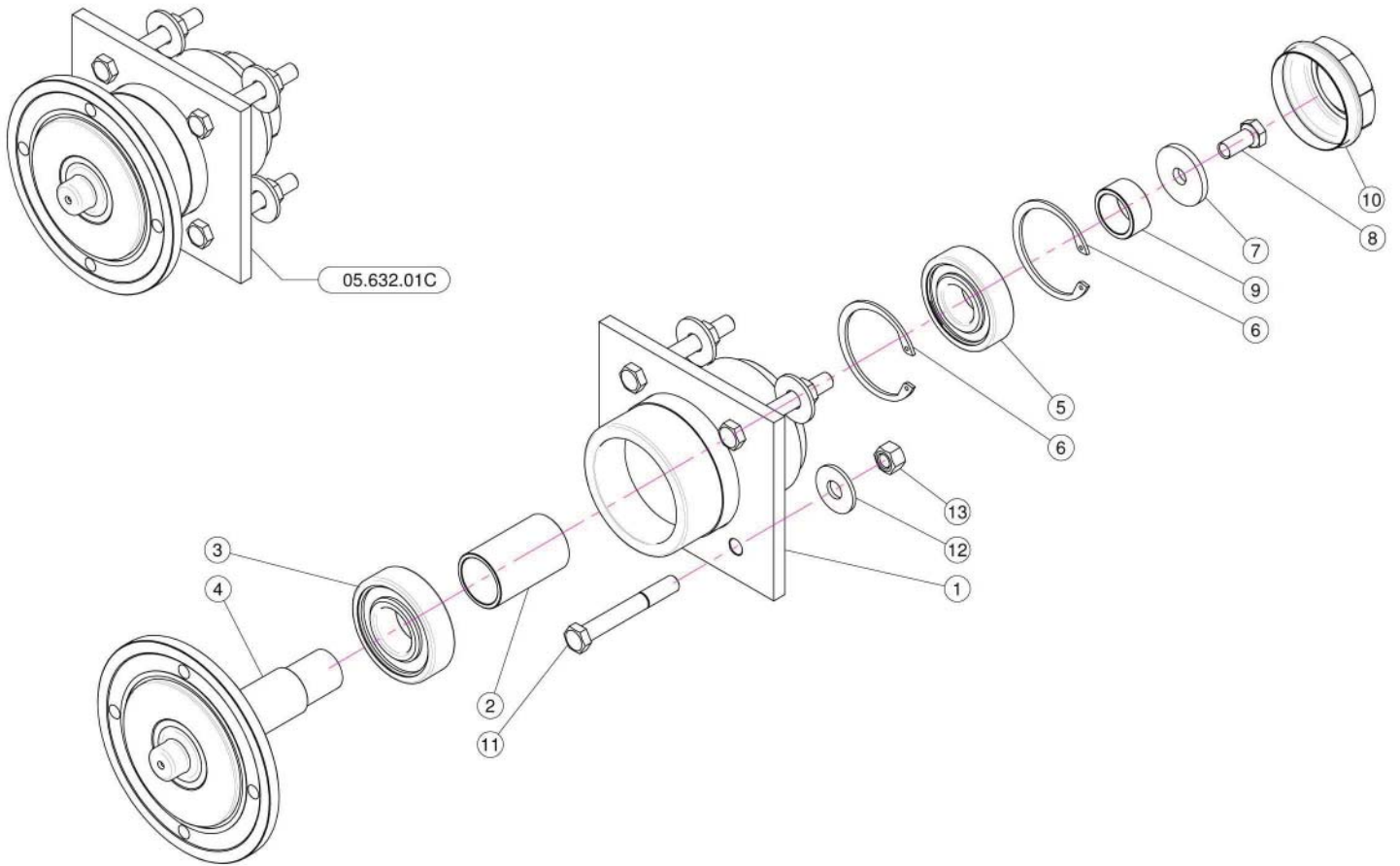

<b>REF.</b>	<b>QTY.</b>	<b>PART NO.</b>	<b>DESCRIPTION</b>
1	1	05.632.000	Lower Support
2	1	04.565.000	Lower Shaft Spacing Bar
3	1	K6.307.2RS	Bearing
4	1	04.589.000	Lower Shaft
5	1	K6.306.2RS	Bearing
6	2	I0.072.000	Spacing Bar
7	1	20.810.000	Special Washer For Lower Support
8	1	TE.012.025FT	Bolt TE M12 x 1.25
9	1	04.590.000	Spacer
10	1	04.555.001	Cover
11	4	TE.012.090	Screw TE M12 x 90
12	4	RP.012.036	Washer D12 x 36
13	4	D0.12.5587G	M12 Nut

## 2.12 LIQUID FLOW PATH

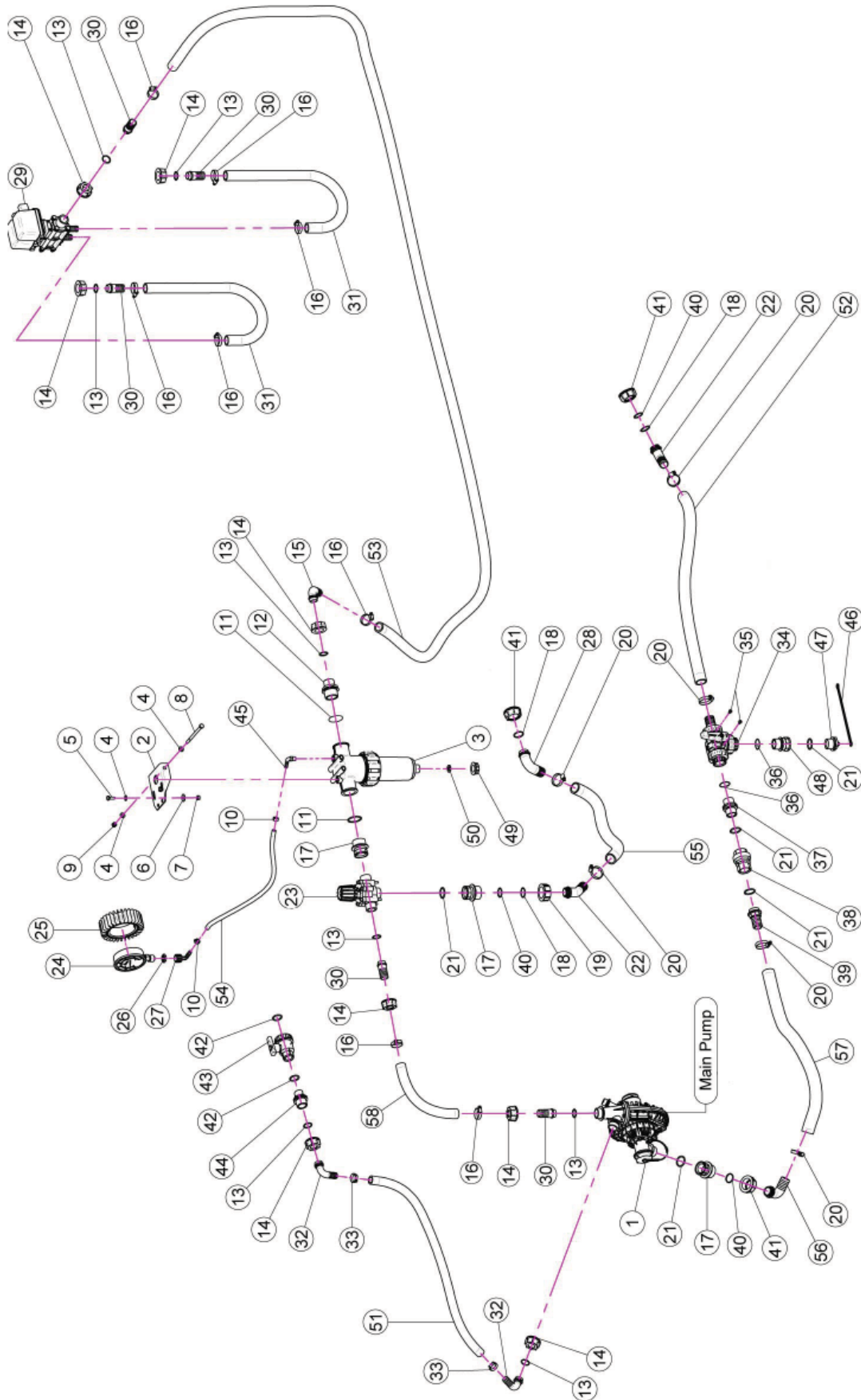

## 2.12 LIQUID FLOW PATH

<u>REF.</u>	<u>QTY.</u>	<u>PART NO.</u>	<u>DESCRIPTION</u>
1	1	02.157.071	Pump
2	1	20.519.100	Bracket
3	1	02.450.110	Line Filter 1" 1/4 Female
4	4	RP.008.000	Washer D.8
5	2	TE.008.025T	Screw TE M8 x 25
6	2	RP.008.024	Washer D.8 x 24
7	2	D0.08.5588G	M8 6S Big Lead Nut 5588
8	1	TE.008.130	Screw M8 x 130
9	1	DA.008.0AG	Self Locking Nut M8
10	2	FC.013.5.015	Hose Clamp
11	2	OR.000.144	O-Ring D.39.69 x 3.53
12	1	00.045.012	1" 1/4 M - 1" M Reducer Nipple
13	7	OR.000.132	23.81 x 2.62 O-Ring Gasket
14	7	00.055.24.2	1" Fly Nut
15	1	00.055.037	D.25 Hosetail
16	8	F0.023.035I	Stainless Steel Clip
17	3	02.374.000	M. / F. 1" F / 1" 1/4M Reduction
18	3	OR.003.112	O-Ring D.25.24 x 2.62
19	1	00.058.006	1" 1/4 Fly Nut
20	6	F0.025.040I	Stainless Steel Clip
21	7	OR.004.118	29.75 x 3.53 O-Ring Gasket
22	2	02.339.000	45" Hosetail
23	1	02.447.000	3-Way Valve
24	1	02.445.000	Pressure Gauge Ø 100 INOX 0-6 Bar
25	1	02.470.000	Pressure Gauge Guard
26	1	24.072.000	Brass Fly Nut 1/2"
27	1	21.012.000	D.12 Hosetail
28	1	00.058.004	D.30 Hosetail
29	1	02.390.09C	Electro Valves
30	4	00.055.021	Staight Hose R.H. D.25
31	2	20.770.000	Hose D.25 x 32 L=1100 (Per Foot)
32	2	00.055.038	Curved Union With R.H. D.19
33	2	FC.026.5.028	Hose Clamp 26.5 - 28
34	1	21.058.300	Three Ways Valve
35	2	TA.006.12P	Screw M6 x 12
36	2	OR.002.125	31.47 x 1.78 O-Ring Gasket
37	1	00.055.034	Nipple 1" / 1" Gas
38	1	21.149.000	Valve 1" F-F.
39	1	00.422.100	Male Connector RH 30 1" Gas
40	1	TM.014.000	Male Plug 1/4"
41	3	OR.003.106	O-Ring D.26.65 x 2.62
42	3	00.493.000	1" 1/4 Fly Nut

## 2.12 LIQUID FLOW PATH

<u>REF.</u>	<u>QTY.</u>	<u>PART NO.</u>	<u>DESCRIPTION</u>
43	2	OR.000.134	O-Ring D.25.8 x 3.53
44	1	02.395.000	Valve 3/4" Gas F.F. Ball
45	1	02.293.000	1" M - 3/4" M Reducer Nipple
46	1	21.084.000	Hosetail 90° WES 8/R1/4
47	2	21.183.000	Cap Stop
48	2	21.182.000	Packing 1" M
49	1	02.384.000	1" M - 1" F Reducer Nipple
50	1	02.182.000	Female 3/4" Cap
51	1	02.030.010	Gasket
52	1	02.212.000	Hose D.19 x 28 L=1000 (Per Foot)
53	1	02.238.000	Hose D.30 x 38 L=900 (Per Foot)
54	1	20.770.000	Hose D.25 x 32 L=3500 (Per Foot)
55	1	02.217.000	Hose D.8 x 13 L=400 (Per Foot)
56	1	20.852.000	Hose D.30 x 41 L=800 (Per Foot)
57	1	02.274.000	Female Tesse 1"
58	1	02.403.000	Straight Hose R.H. D.25 - 1"
59	1	OR.000.507	27 x 5 O-Ring Gasket
60	1	20.809.000	Hose D.25 x 32 L=300 (Per Foot)
61	1	00.483.000	D.30 1 - 1/4" Hosetail
62	1	20.852.000	Hose D.30 L=800 (Per Foot)

## 2.13 PUMPS & ROUTING

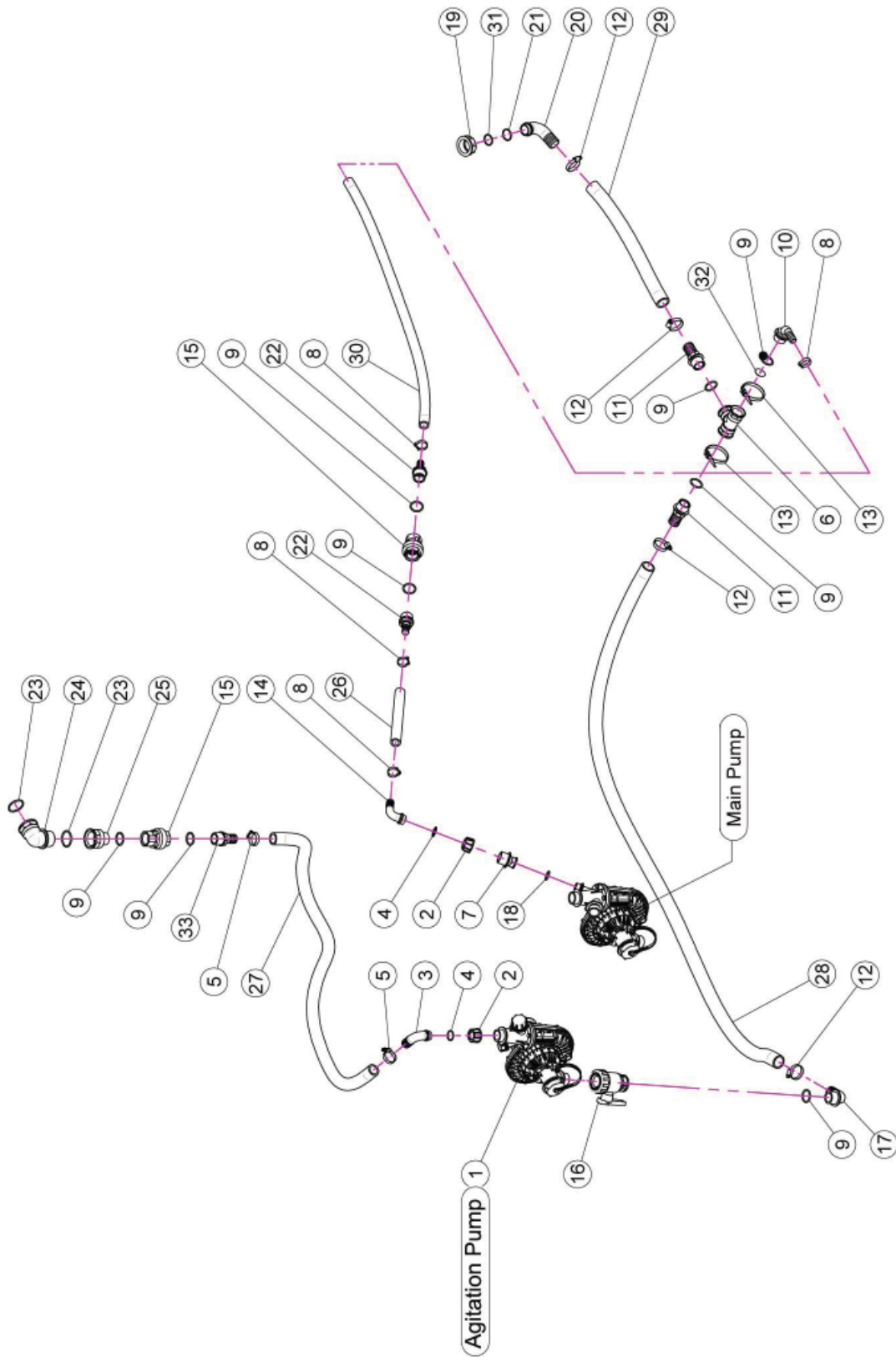



## 2.13 PUMPS & ROUTING

<u>REF.</u>	<u>QTY.</u>	<u>PART NO.</u>	<u>DESCRIPTION</u>
1	1	02.157.062	Pump
2	2	00.055.24.2	1" Fly Nut
3	1	00.055.037	D.25 Hosetail
4	2	OR.000.132	23.81 x 2.62 O-Ring Gasket
5	2	F0.023.035I	Stainless Steel Clip
6	1	02.274.000	Female Tesse 1"
7	1	21.186.000	Reducer Nipple 1" M - 1/2" F
8	4	FC.026.5.028	Hose Clamp 26.5 - 28
9	8	OR.004.118	29.75 x 3.53 O-Ring Gasket
10	1	21.193.000	Hosetail 90° 1" R.H.
11	2	00.422.000	Male Connector R.H. 30 1" Gas
12	4	F0.025.040I	Stainless Steel Clip
13	2	02.355.000	Nylon Assembly Clamp
14	1	00.055.038	Curved Union With R.H. D.19
15	2	21.149.000	Valve 1" F-F.
16	1	04.109.000	Two-Ways Valve
17	1	00.465.000	Hosetail D.30 1" Gas
18	1	OR.004.081	20.22 x 3.53 O-Ring Gasket
19	1	00.493.000	1" 1/4" Fly Nut
20	1	00.483.000	D.30 1 - 1/4" Hosetail
21	1	OR.003.112	O-Ring D.28.24 x 2.62
22	2	02.402.100	Straight Hose R.H. D.19 - 1"
23	2	OR.000.144	O-Ring D.39.69 x 3.53
24	1	24.070.000	Hosetail 1" 1/4
25	1	02.361.100	Reducer Nipple 1" 1/4 F - 1" M (Cut)
26	1	02.212.000	Hose D.19 L=170 (Per Foot)
27	1	20.809.000	Hose D.25 L=1200 (Per Foot)
28	1	20.852.000	Hose D.30 L=1500 (Per Foot)
29	1	20.852.000	Hose D.30 L=1100 (Per Foot)
30	1	02.212.000	Hose D.19 L=1200 (Per Foot)
31	1	OR.003.106	O-Ring D.26.65 x 2.62
32	1	40.386.000	Washer With Hole D.4 x Tee-Piece Union 2° Pump
33	1	02.403.000	Straight Hose R.H. D.25 - 1"

## 2.14 PRESSURE REGULATOR & 3 WAY VALVE

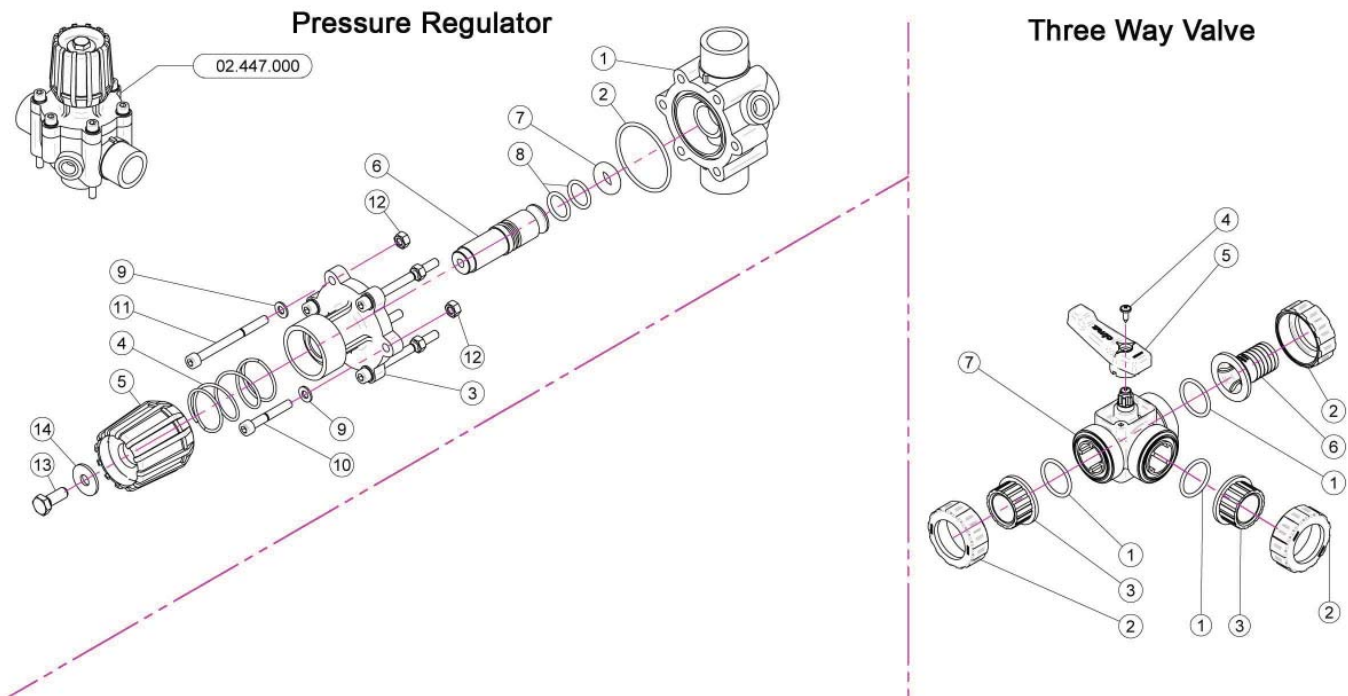

### PRESSURE REGULATOR

<u>REF.</u>	<u>QTY.</u>	<u>PART NO.</u>	<u>DESCRIPTION</u>
-------------	-------------	-----------------	--------------------

1	1	02.447.001	Body For Regulator Valve
2	1	OR.003.193	O-Ring Gasket 48.89 x 2.62
3	1	02.447.009	Upper Flange
4	1	02.447.011	Spring
5	1	02.447.010	Regulation Valve Knob
6	1	02.447.014	Valve Pin
7	1	02.447.005	Special O-Ring For Gate 2447
8	2	OR.003.068	O-Ring Gasket 17.12 x 2.62
9	6	RP.006.000	Washer D.6
10	2	TCE.006.040	Bolt TCE M6 x 40
11	4	TCE.006.070	Bolt TCE M6 x 70
12	6	D0.06.5588G	Nut M6
13	1	TE.008.025I	INOX 8 x 25 Screw
14	1	RP.008.024I	INOX Washer D.8 x 24

### 3-WAY VALVE

1	3	OR.004.137	O-Ring D.34.52 x 3.53
2	3	21.058.007	Valve Union Nut
3	2	21.058.006	Valve End Connector
4	1	TA.05.5.016	Self Threaded Screw M5.5 x 16
5	1	21.058.003	Valve Handle
6	1	21.058.009	Rubber Holder D.30
7	1	21.058.110	Body of Three Way Valve

## 2.15 SUCTION FILTER ASSEMBLY

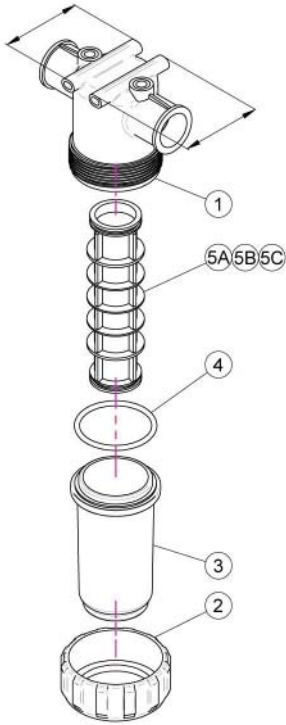

### 02.450.010

<u>REF.</u>	<u>QTY.</u>	<u>PART NO.</u>	<u>DESCRIPTION</u>
1	1	02.450.001	Line Filter Body
2	1	02.450.003	Ring Nut Filter In Line
3	1	02.450.011	Lid Filter With Unloading
4	1	OR.000.178	O-Ring D.74.63 x 5.33
5A	1	02.450.004C	Cartridge w/ O-Ring 50 Mesh (Blue)
5B	1	02.450.204C	Cartridge w/ O-Ring 80 Mesh (Grey)
5C	1	02.450.104C	Cartridge w/ O-Ring 32 Mesh (White)

## 2.16 MAIN PUMP BREAKDOWN - T55S2-2000

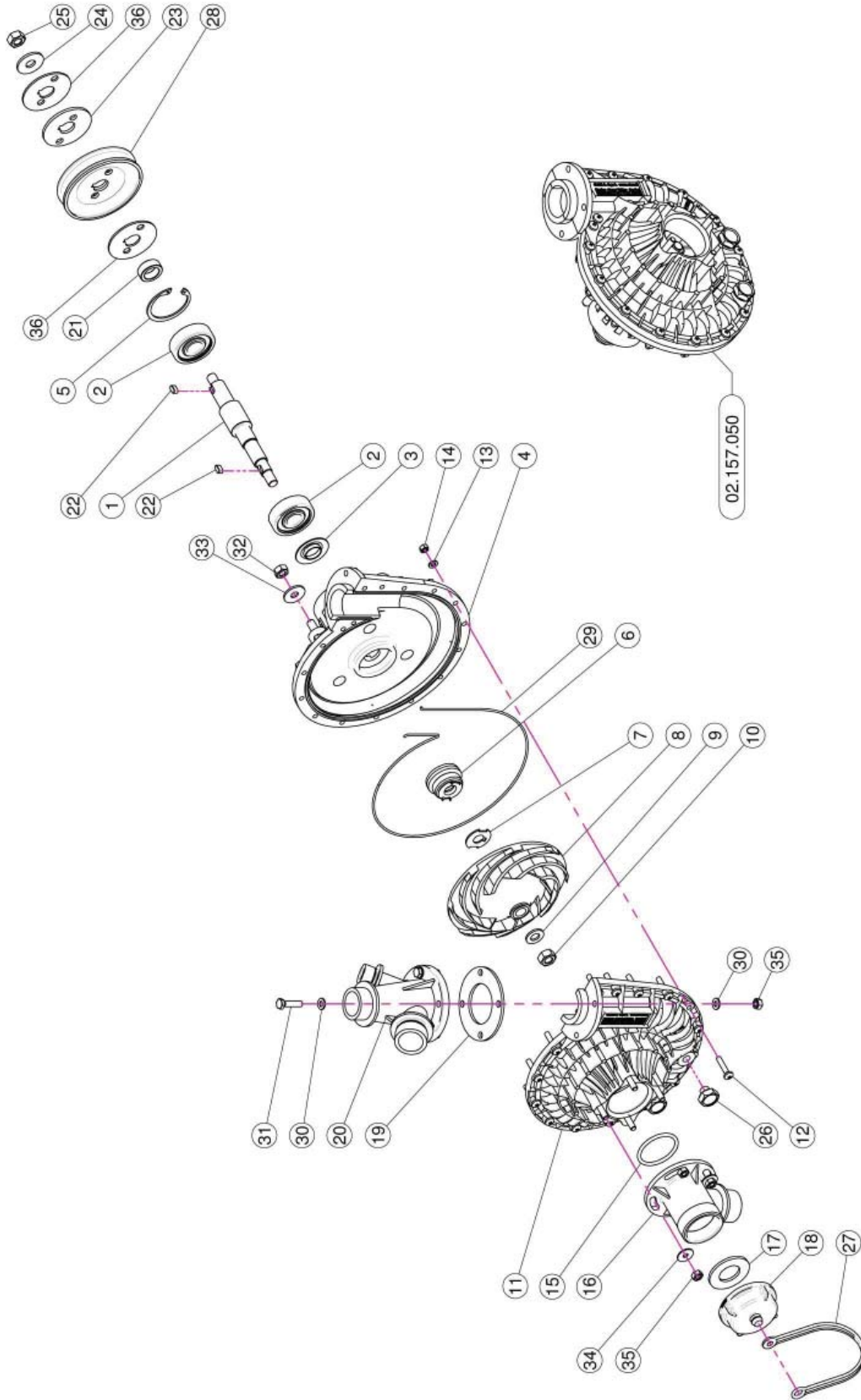

## 2.16 MAIN PUMP BREAKDOWN - T55S2-2000

<u>REF.</u>	<u>QTY.</u>	<u>PART NO.</u>	<u>DESCRIPTION</u>
1	1	02.155.010	CD32 Pump Shaft
2	2	K6.303.2RS	Roller Bearing
3	1	20.406.000	Special Cover For Pump
4	1	02.151.010	Pump Casing
5	1	I0.047.000	Internal D.47 Circlip
6	1	00.085.024CS	Mechanical Seal
7	1	02.114.000	INOX Special Washer
8	1	02.153.000	CD 32 Pump Impeller
9	1	RP.010.00I	Washer D.10 INOX
10	1	DOT.10.5587	M10 Brass Nut
11	1	02.152.010	Housing
12	17	TC.05.25.85	Cross Slotted Screw M5 x 25
13	17	RP.005.000	Washer D.5
14	17	DOT.05.5587	M5 Brass Nut (5587)
15	1	OR.000.144	O-Ring D.39.69 x 3.53
16	1	02.116.000	Suction Fitting
17	1	02.130.000	24 x 46 x 3 Rubber Gasket
18	1	02.120.000	Rapid Thread Cap
19	1	02.179.000	Rubber Gasket
20	1	02.113.000	Delivery Fitting
21	1	02.722.000	Bush
22	2	L.05.05.10	5 x 5 x 10 Tang
23	1	02.723.001	Special Washer MM3
24	1	RP.010.030	Washer D.10 x 30 MM
25	1	D0.10.5588G	M10 6S Big Lead Nut 5588
26	2	TM.010.015	M10 x 1.5 Cap
27	1	21.183.000	Cap Stop
28	1	02.723.000	Pulley For Pump D.88 x 1 3V
29	1	OR.C02.070	OR Cord D.2 L=700
30	8	RP.006.000	Washer D.6
31	4	TE.006.025T	Screw TE M6 x 25
32	3	D0.08.5588G	M8 6S Big Lead Nut 5588
33	3	RP.008.024	Washer D.8 x 24
34	3	RP.006.018	Washer D.6 x 18
35	8	DOT.06.5587	M6 Brass Nut 5587
36	2	02.723.005	Special Washer MM2

## 2.16 MAIN PUMP BREAKDOWN - T55E2-2000

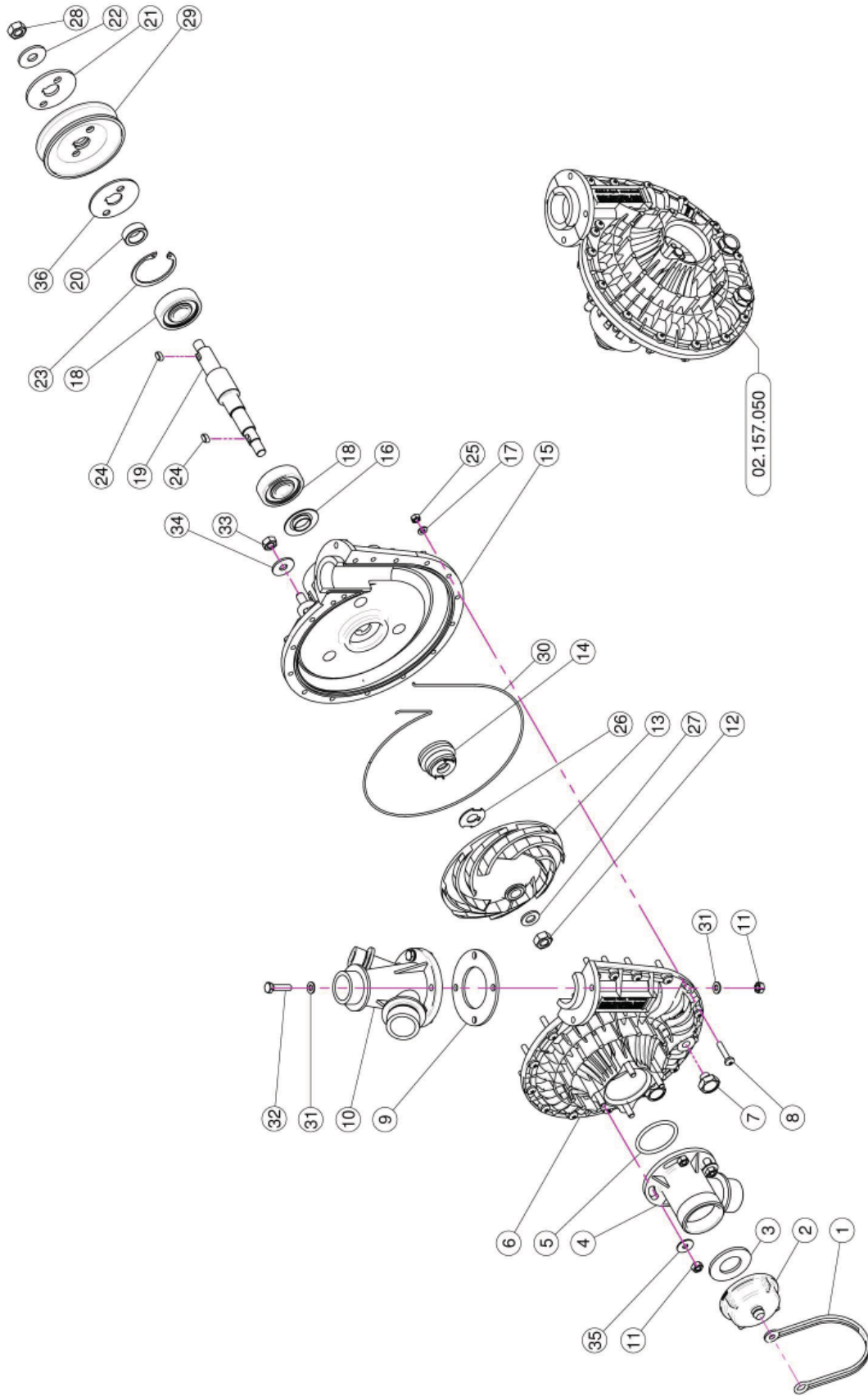

## 2.16 MAIN PUMP BREAKDOWN - T55E2-2000

<u>REF.</u>	<u>QTY.</u>	<u>PART NO.</u>	<u>DESCRIPTION</u>
1	1	21.183.000	Cap Stop
2	1	02.120.000	Rapid Thread Cap
3	1	02.130.000	24 x 46 x 3 Rubber Gasket
4	1	02.116.000	Suction Fitting
5	1	OR.000.144	O-Ring D.39.69 x 3.53
6	1	02.152.010	Housing
7	2	TM.010.015	M10 x 1.5 Cap
8	17	TC.05.25.85	Cross Slotted Screw M5 x 25
9	1	02.179.000	Rubber Gasket
10	1	02.113.000	Delivery Fitting
11	8	DOT.06.5587	M6 Brass Nut 5587
12	1	DOT.10.5587	M10 Brass Nut
13	1	02.153.000	CD 32 Pump Impeller
14	1	00.085.024CS	Mechanical Seal
15	1	02.151.010	Pump Casing
16	1	20.406.000	Special Cover For Pump
17	17	RP.005.000	Washer D.5
18	2	K6.303.2RS	Roller Bearing
19	1	02.155.010	CD32 Pump Shaft
20	1	02.722.000	Bush
21	1	02.723.001	Special Washer MM3
22	1	RP.010.030	Washer D.10 x 30MM
23	1	I0.047.000	Internal D.47 Circlip
24	2	L.05.05.10	5 x 5 x 10 Tang
25	17	DOT.05.5587	M5 Brass Nut (5587)
26	1	02.114.000	INOX Special Washer
27	1	RP.010.00I	Washer D.10 INOX
28	1	D0.10.5588G	M10 6S Big Lead Nut 5588
29	1	02.723.002	Pulley For Pump D.82.5 x 1 3V
30	1	OR.C02.070	OR Cord D.2 L=700
31	8	RP.006.000	Washer D.6
32	4	TE.006.025T	Screw TE M6 x 25
33	3	D0.08.5588G	M8 6S Big Lead Nut 5588
34	3	RP.008.024	Washer D.8 x 24
35	3	RP.006.018	Washer D.6 x 18
36	1	02.723.005	Special Washer MM2

## 2.17 AGITATION PUMP BREAKDOWN - T55S2-2000

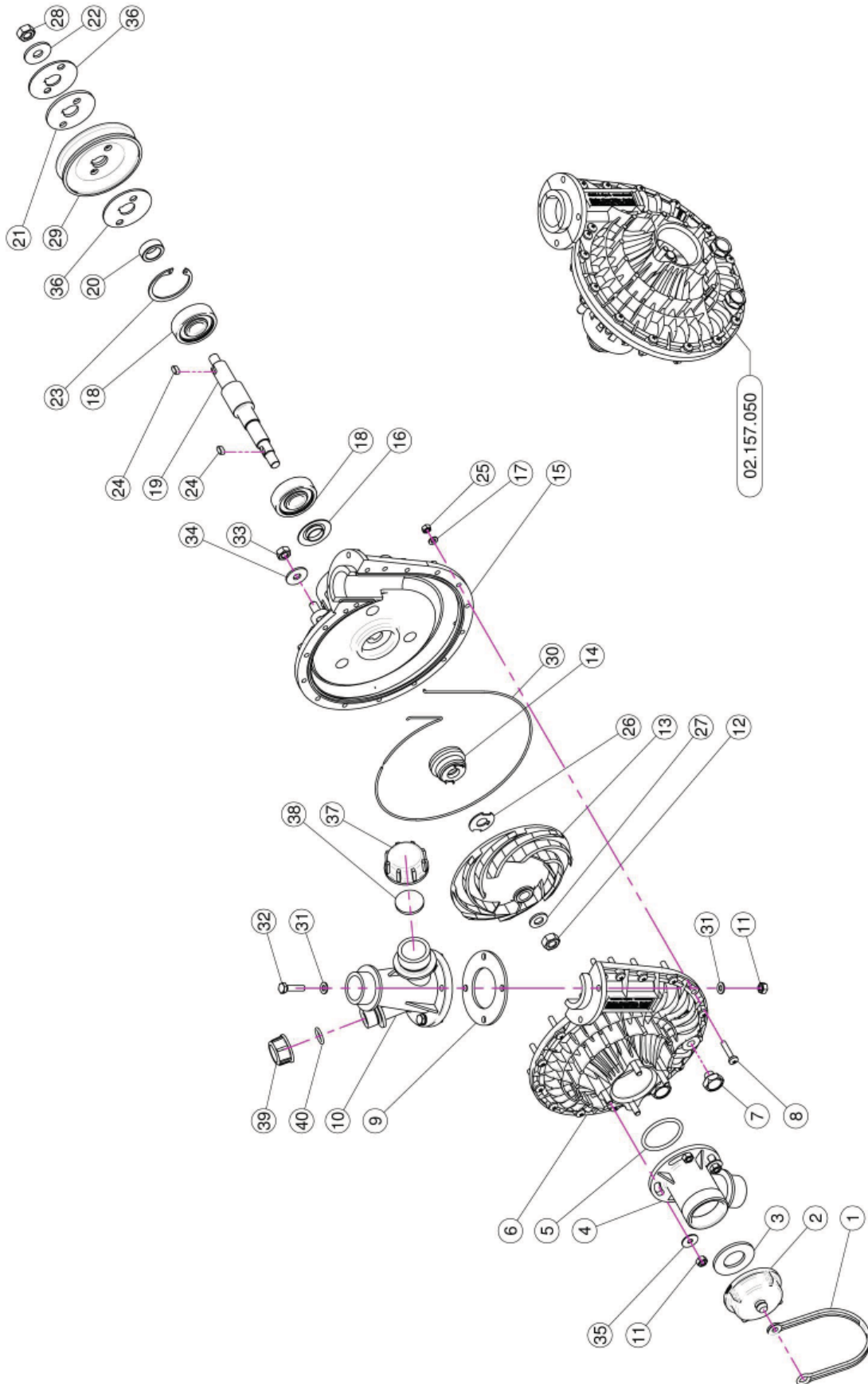



## 2.17 AGITATION PUMP BREAKDOWN - T55S2-2000

<u>REF.</u>	<u>QTY.</u>	<u>PART NO.</u>	<u>DESCRIPTION</u>
1	1	21.183.000	Cap Stop
2	1	02.120.000	Rapid Thread Cap
3	1	02.130.000	24 x 46 x 3 Rubber Gasket
4	1	02.116.000	Suction Fitting
5	1	OR.000.144	O-Ring D.39.69 x 3.53
6	1	02.152.010	Housing
7	2	TM.010.015	M10 x 1.5 Cap
8	17	TC.05.25.85	Cross Slotted Screw M5 x 25
9	1	02.179.000	Rubber Gasket
10	1	02.113.000	Delivery Fitting
11	8	DOT.06.5587	M6 Brass Nut 5587
12	1	DOT.10.5587	M10 Brass Nut
13	1	02.153.000	CD 32 Pump Impeller
14	1	00.085.024CS	Mechanical Seal
15	1	02.151.010	Pump Casing
16	1	20.406.000	Special Cover For Pump
17	17	RP.005.000	Washer D.5
18	2	K6.303.2RS	Roller Bearing
19	1	02.155.010	CD32 Pump Shaft
20	1	02.722.000	Bush
21	1	02.723.001	Special Washer MM3
22	1	RP.010.030	Washer D.10 x 30MM
23	1	I0.047.000	Internal D.47 Circlip
24	2	L.05.05.10	5 x 5 x 10 Tang
25	17	DOT.05.5587	M5 Brass Nut (5587)
26	1	02.114.000	INOX Special Washer
27	1	RP.010.00I	Washer D.10 INOX
28	1	D0.10.5588G	M10 6S Big Lead Nut 5588
29	1	02.723.000	Pulley For Pump D.88 x 1 3V
30	1	OR.C02.070	OR Cord D.2 L=700
31	8	RP.006.000	Washer D.6
32	4	TE.006.025T	Screw TE M6 x 25
33	3	D0.08.5588G	M8 6S Big Lead Nut 5588
34	3	RP.008.024	Washer D.8 x 24
35	3	RP.006.018	Washer D.6 x 18
36	2	02.723.005	Special Washer MM2
37	1	TF.001.000	Packing
38	1	24.100.000	Gasket D.30 x 3
39	1	TF.012.000	Blank Cap 1/2"
40	1	OR.000.117	13.1 x 18.34 x 2.62 O-Ring Gasket

## 2.17 AGITATION PUMP BREAKDOWN - T55E2-2000

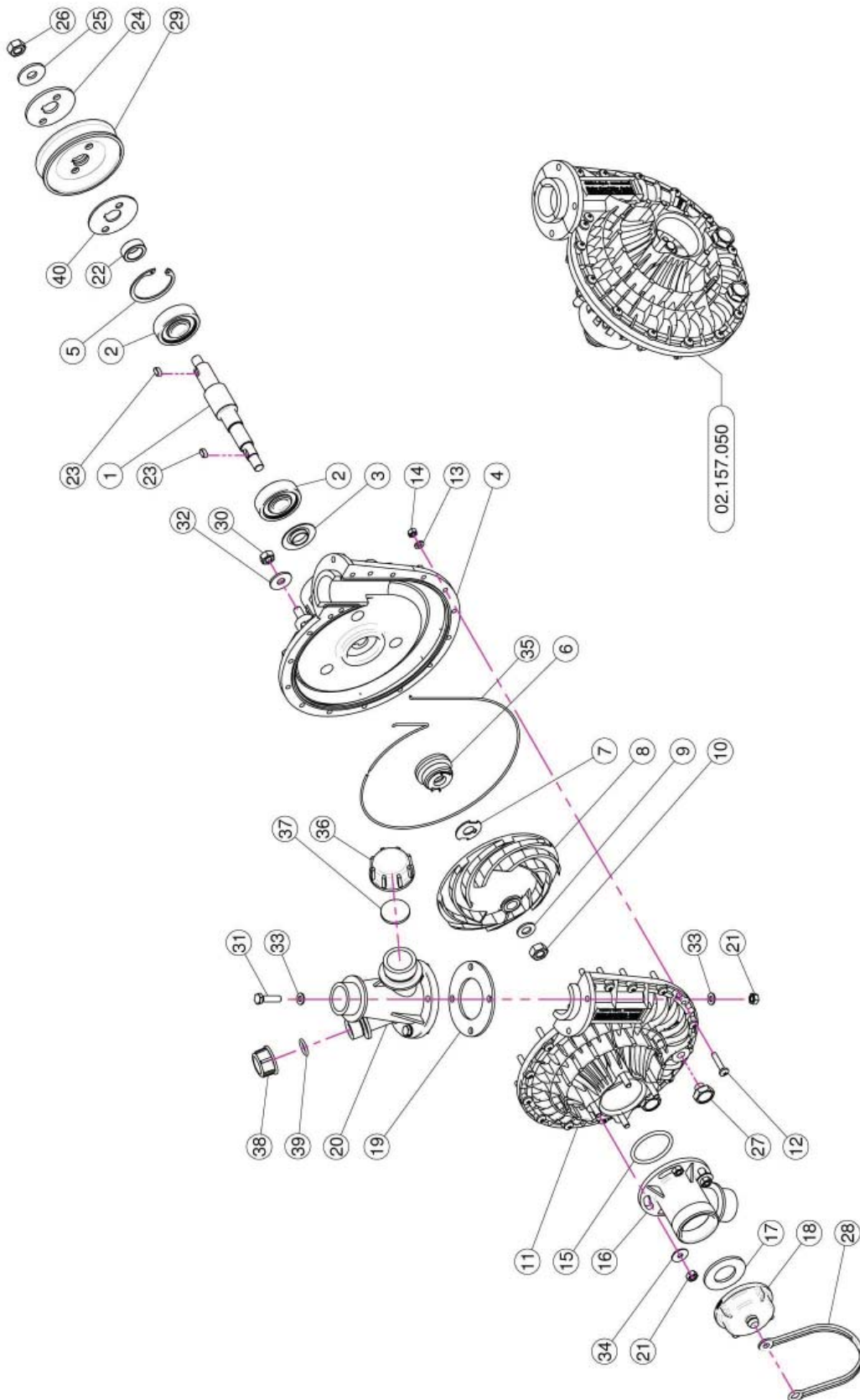

## 2.17 AGITATION PUMP BREAKDOWN - T55E2-2000

<u>REF.</u>	<u>QTY.</u>	<u>PART NO.</u>	<u>DESCRIPTION</u>
1	1	02.155.010	CD32 Pump Shaft
2	2	K6.303.2RS	Roller Bearing
3	1	20.406.000	Special Cover For Pump
4	1	02.151.010	Pump Casing
5	1	I0.047.000	Internal D.47 Circlip
6	1	00.085.024CS	Mechanical Seal
7	1	02.114.000	INOX Special Washer
8	1	02.153.000	CD 32 Pump Impeller
9	1	RP.010.00I	Washer D.10 INOX
10	1	DOT.10.5587	M10 Brass Nut
11	1	02.152.010	Housing
12	17	TC.05.25.85	Cross Slotted Screw M5 x 25
13	17	RP.005.000	Washer D.5
14	17	DOT.05.5587	M5 Brass Nut (5587)
15	1	OR.000.144	O-Ring D.39.69 x 3.53
16	1	02.116.000	Suction Fitting
17	1	02.130.000	24 x 46 x 3 Rubber Gasket
18	1	02.120.000	Rapid Thread Cap
19	1	02.179.000	Rubber Gasket
20	1	02.113.000	Delivery Fitting
21	8	DOT.06.5587	M6 Brass Nut 5587
22	1	02.722.000	Bush
23	2	L.05.05.10	5 x 5 x 10 Tang
24	1	02.723.001	Special Washer mm 3
25	1	RP.010.030	Washer D.10 x 30 MM
26	1	D0.10.5588G	M10 6S Big Lead Nut 5588
27	2	TM.010.015	M10 x 1.5 Cap
28	1	21.183.000	Cap Stop
29	1	02.723.002	Pulley For Pump D.82.5 x 1 3V
30	3	D0.08.5588G	M8 6S Big Lead Nut 5588
31	4	TE.006.025T	Screw TE M6 x 25
32	3	RP.008.024	Washer D.8 x 24
33	8	RP.006.000	Washer D.6
34	3	RP.006.018	Washer D.6 x 18
35	1	OR.C02.070	OR Cord D.2 L=700
36	1	TF.001.000	Packing
37	1	24.100.000	Gasket D.30 x 3
38	1	TF.012.000	Blank Cap 1/2"
39	1	OR.000.117	13.1 x 18.34 x 2.62 O-Ring Gasket
40	1	02.723.005	Special Washer mm 2

## 2.18 CONTROL BOX 910208/T

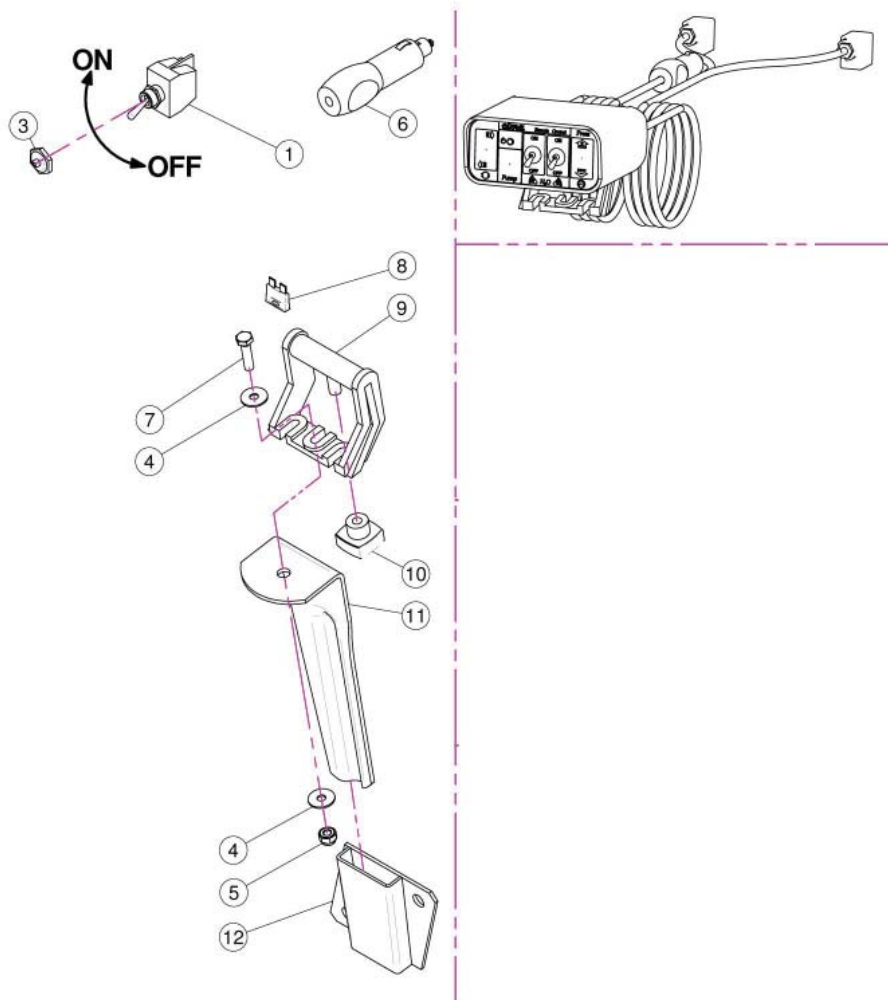

<u>REF.</u>	<u>QTY.</u>	<u>PART NO.</u>	<u>DESCRIPTION</u>
1	2	21.030.005	Switch 2V 2P On-Off 10A
3	2	21.030.007	Switch Cap D.12
4	2	RP.006.018	Washer D.6 x 18
5	1	DA.006.0AG	Self Locking Nut - High M6
6	1	21.030.008	12V Power Jack
7	1	TE.006.025T	Screw TE M6 x 25
8	1	21.030.004	10 Ah Fuse
9	1	21.030.002	Moving Fixing Bracket
10	1	21.030.003	Fixing Knob
11	1	20.111.000	Bracket
12	1	20.107.000	Female Bayonet Support

## 2.19 ELECTRO VALVES

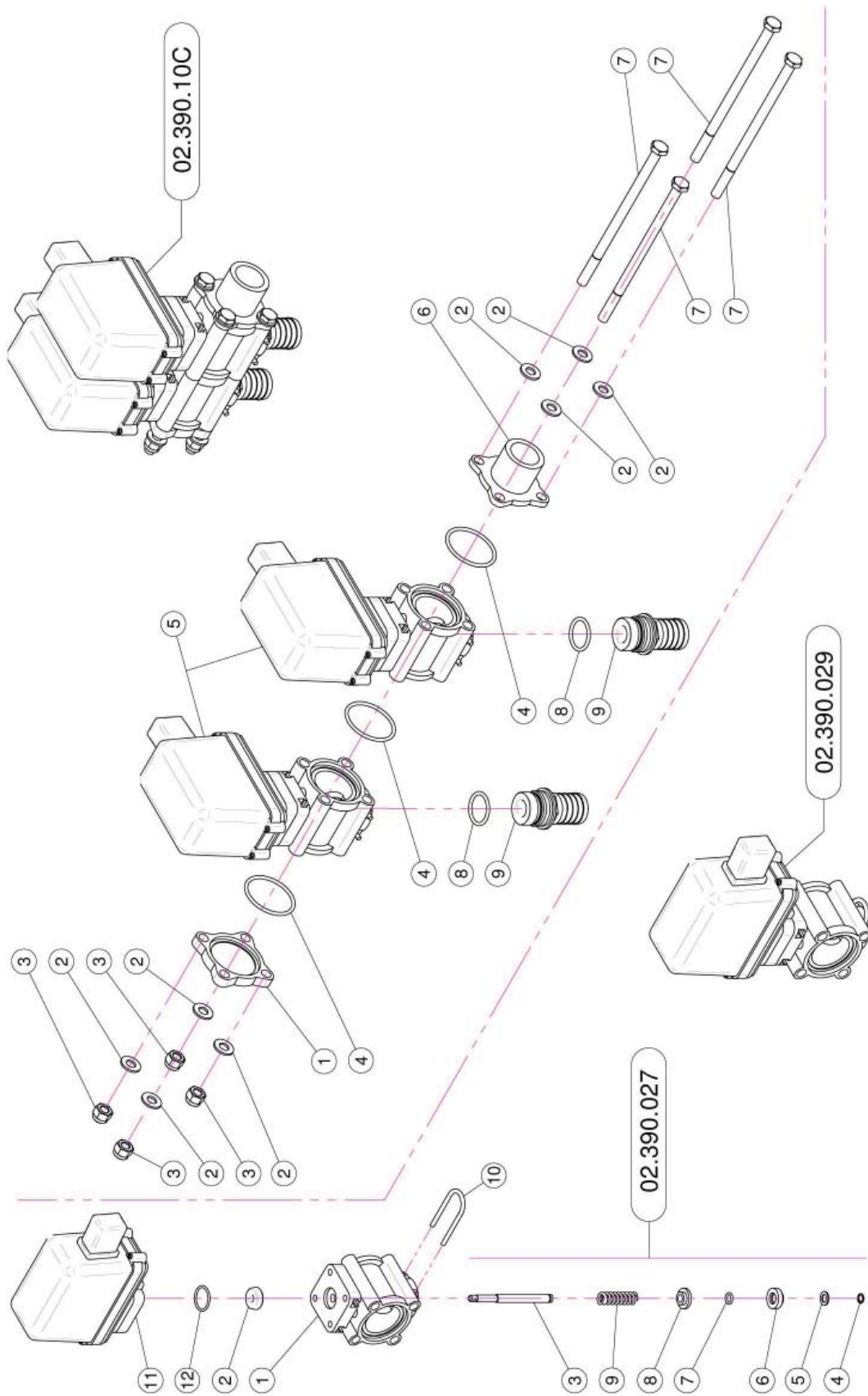

## 2.19 ELECTRO VALVES

### 02.390.029

<u>REF.</u>	<u>QTY.</u>	<u>PART NO.</u>	<u>DESCRIPTION</u>
1	1	02.390.007	Valve Body
2	1	02.390.008	Gasket
3	1	02.390.020	Pin
4	1	02.390.013	Stop Ring
5	1	02.390.014	Washer 7.2 x 12 INOX
6	1	02.390.015	Lower Valve
7	1	02.390.016	O-Ring
8	1	02.390.009	Superior Valves
9	1	02.390.011	Spring
10	1	21.130.005	Fork
11	1	02.390.028	Solenoid Valve
12	1	OR.002.075	D.18.77 x 1.78 O-Ring

### 02.390.10C

1	1	02.390.017	Valve Flange
2	8	RP.008.000	Washer D.8
3	4	DA.008.0AG	Self Locking Nut M8
4	3	OR.003.156	O-Ring Gasket 39.34 x 2.62
5	2	02.390.029	Solenoid Valve
6	1	02.390.018	Connector
7	4	TE.008.150	Screw TE M8 x 150
8	2	OR.000.130	22.22 x 2.62 O-Ring Gasket
9	2	20.094.000	Hosetail D.25

## 2.20 PUMP & FAN BELTS

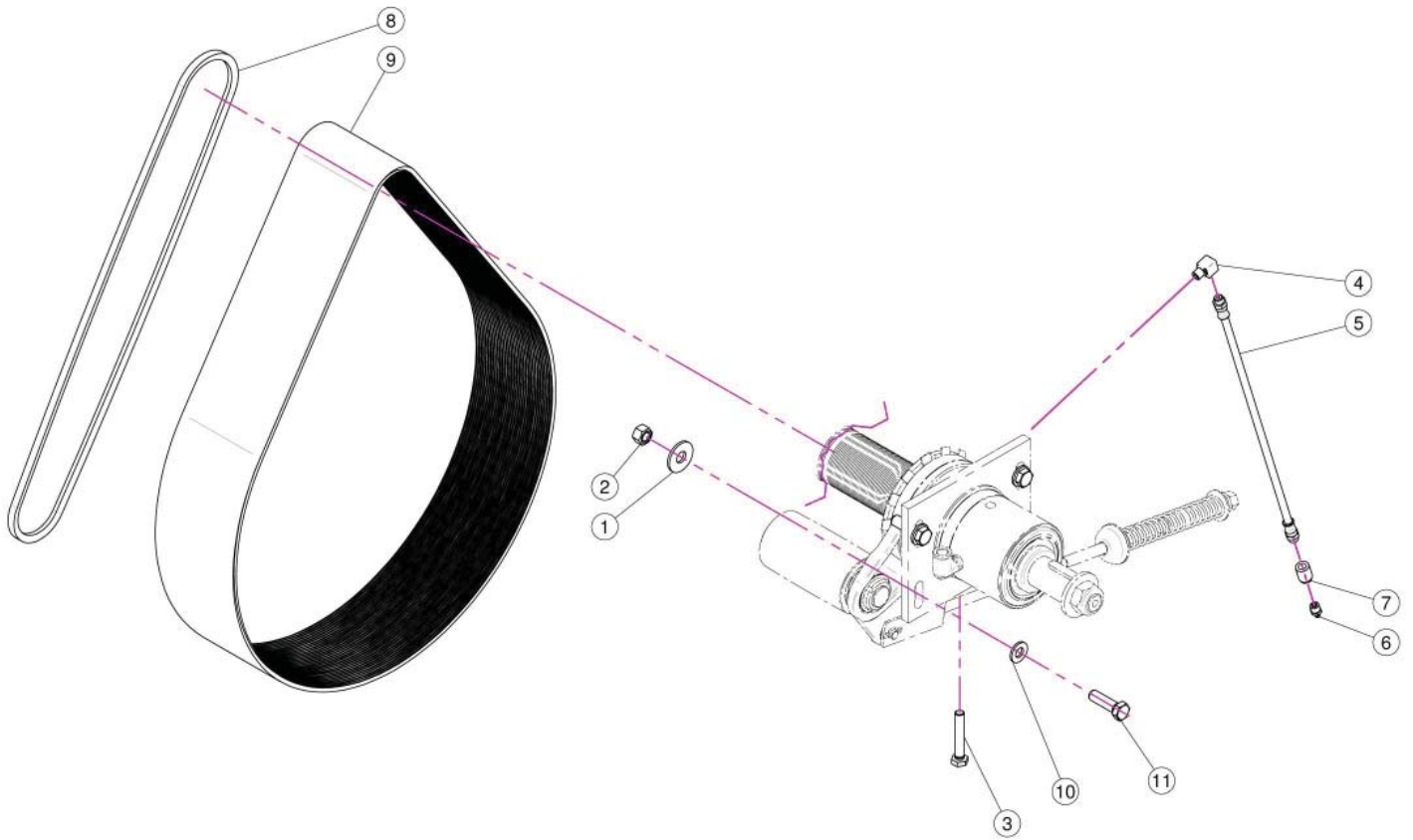

<b>REF.</b>	<b>QTY.</b>	<b>PART NO.</b>	<b>DESCRIPTION</b>
1	4	RP.012.036	Washer D12 x 36
2	4	D0.12.5587G	M12 Nut
3	1	TE.010.060T	Screw TE M10 x 60
4	1	02.736.000	90 G. M10 x 1 Fitting
5	1	02.738.040	Greaser Extension M10 x 1 L=400
6	1	ID.010.001	Grease Nipple
7	1	02.737.000	Accessori
8	2	C0.500.03V	V-Belt
9	1	C0.690.J50	Poly V-Belt
10	2	RP.012.000	Washer D.12
11	4	TE.012.040T	Bolt TE M12 x 40

## 2.21 AXLE & WHEEL HUBS

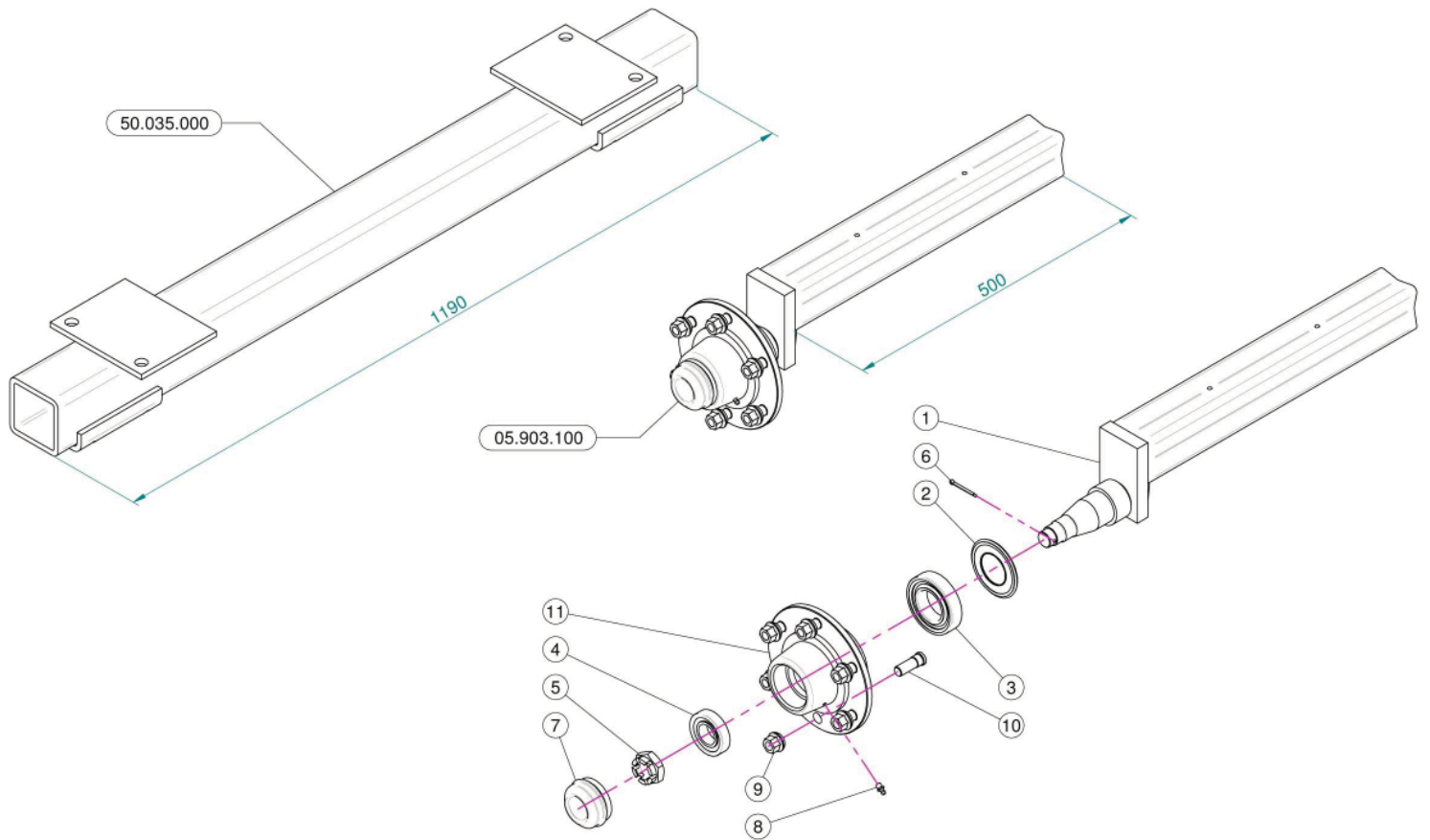

<u>REF.</u>	<u>QTY.</u>	<u>PART NO.</u>	<u>DESCRIPTION</u>
1	1	05.971.101	Axle Shaft
2	1	20.258.000	Oil Cover
3	1	K0.030.209	Bearing
4	1	K0.030.206	Bearing
5	1	DI.027.5594F	Six Castle Nut M27
6	1	20.259.000	Split Pin
7	1	04.062.001	Cover
8	1	ID.006.001	Greaser
9	6	05.911.000	Special Nut
10	6	05.911.001	Stud
11	1	05.903.001	Six Holes Flange



## 2.22 TANK AGITATION PARTS

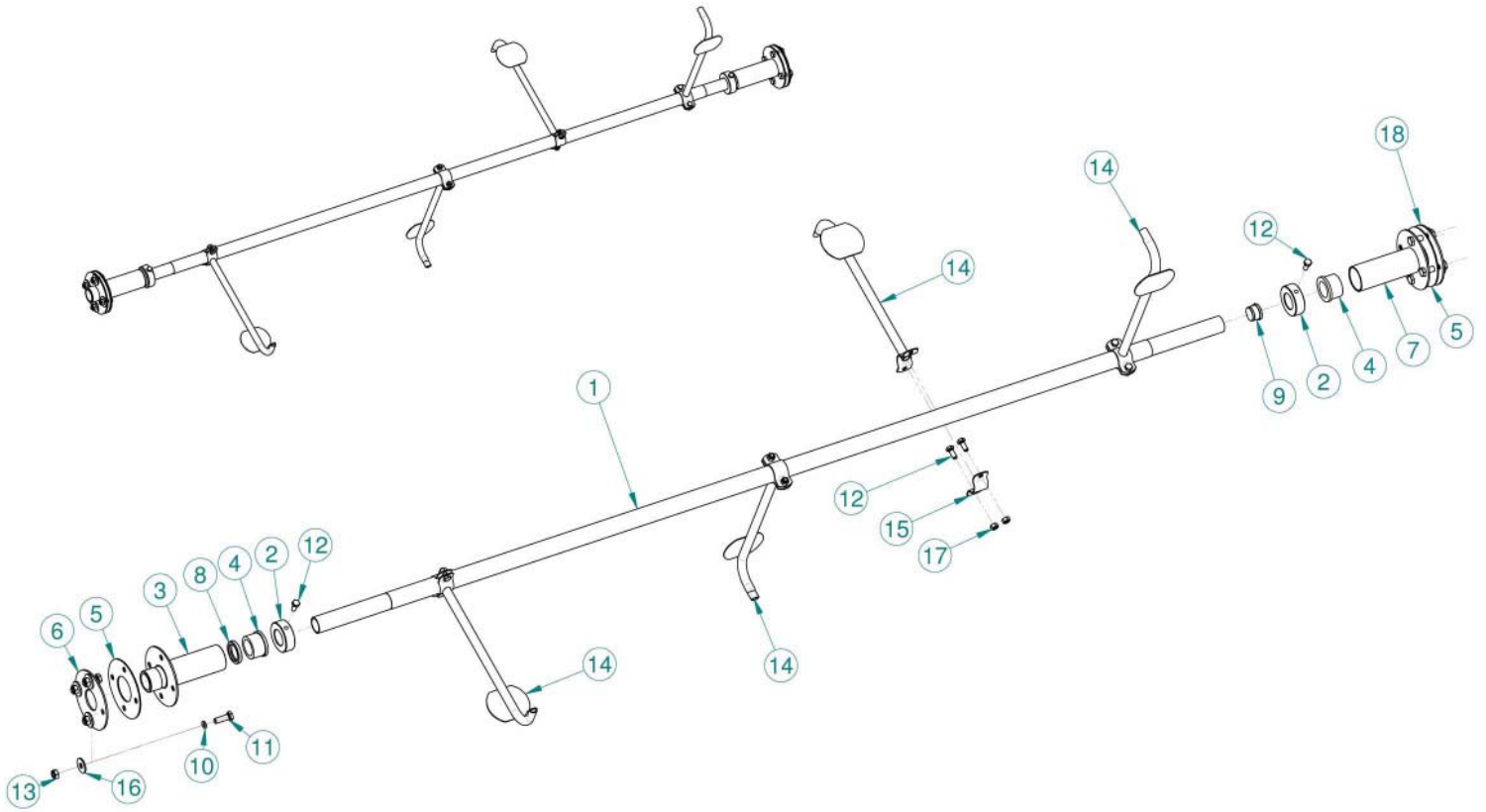

<b>REF.</b>	<b>QTY.</b>	<b>PART NO.</b>	<b>DESCRIPTION</b>
1	1	50.050.000	Hydraulic Agitator Shaft
2	2	50.052.100	Lock Bush
3	1	50.044.050	Front Steel Support
4	2	50.046.000	Shaft Teflon Bush
5	2	50.048.050	Gasket
6	1	50.047.050	External Fixing Anterior Flange
7	1	50.045.050	Posterior Steel Support
8	1	BA.32.45.07	32 x 45 x 7 Sealing Ring
9	1	50.107.000	Cap For Shaft
10	8	OR.000.112	D.9.92 x 2.62 O-Ring Gasket
11	8	TE.010.030I	INOX M10 x 30 Screw
12	10	TE.008.025I	INOX 8 x 25 Screw
13	8	DOT.10.5587	M10 Brass Nut
14	8	50.055.100	Agitator Blade
15	4	50.053.000	Bracket
16	8	RP.010.030	Washer D.10 x 30 mm
17	8	DOT.08.5587	M8 Brass Nut
18	1	50.051.050	Fixing Posterior Flange

## 2.23 DRIVESHAFT - WB8105

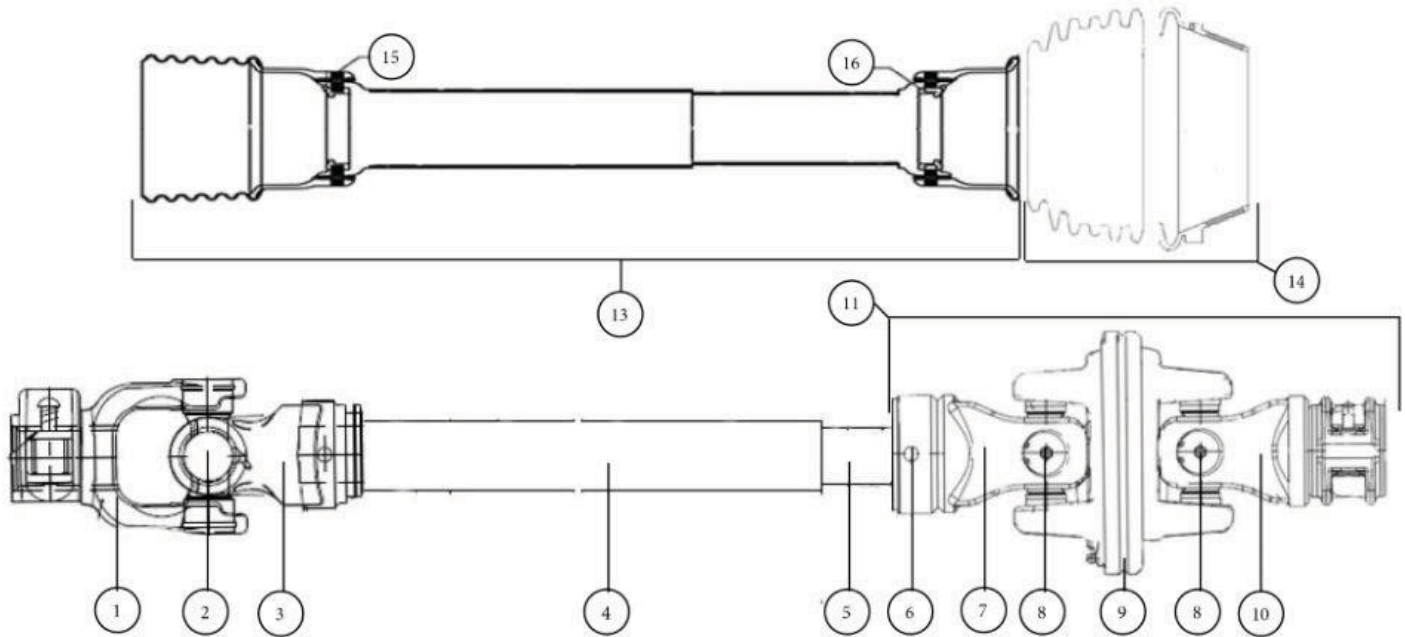

<b>REF.</b>	<b>PART NO.</b>	<b>DESCRIPTION</b>
1	A824138	Quick Release Yoke 1 3/8" x 6-Spline
2	A824	Universal Cross
3	A8263	Outer Tube Yoke
4	A634	Outer Drive Tube
5	A454	Inner Drive Tube
6	A1090	Poll Pin (2 Required)
7	Order Joint	Inner C.V. Yoke
8	AG3606	C.V. Universal Cross (2 Required)
9	AG36000	C.V. Center Disc Assembly
10	AG366138	C.V. End Yoke 1 3/8" x 6-Spline
11	AG8001	C.V. Joint Assembly 1 3/8" x 6-Spline
12	AB121	Quick Release Button
13	AS30090	Guard Center Assembly Includes Bearings
14	ASW7100	Guard Wide Angle Attachment
15	AS301	Release Lever Kit
16	ASB3	Bearing Kit

### 3 LIMITED WARRANTY



GEARMORE, INC., warrants each new Gearmore product to be free from defects in material and workmanship for a period of twelve (12) months from date of purchase to the original purchaser. This warranty shall not apply to implements or parts that have been subject to misuse, negligence, accident, or that have been altered in any way.

Our obligation shall be limited to repairing or replacement of any part, provided that such part is returned within thirty (30) days from date of failure to Gearmore through the dealer from whom the purchase was made, transportation charges prepaid.

This warranty shall not be interpreted to render us liable for injury or damages of any kind or nature, direct, consequential or contingent, to person or property. This warranty does not extend to loss of crops, loss because of delay in harvesting or any other expenses, for any other reasons.

Gearmore in no way warrants engines, tires, or other trade accessories, since these items are warranted separately by these respective manufacturers.

Gearmore reserves the right to make improvements in design or changes in specification at any time, without incurring any obligations to owners or units previously sold.

Please be advised that all warranty work done by your dealer must be approved by Gearmore before work begins.

GEARMORE, INC.  
13477 Benson Ave.  
Chino, CA 91710

Always refer to and heed machine operating warning decals on machine.

*To validate the warranty on this product, please log-in to our website - [www.gearmore.com](http://www.gearmore.com).  
You will find "warranty registration" listed at the top of our homepage.*