

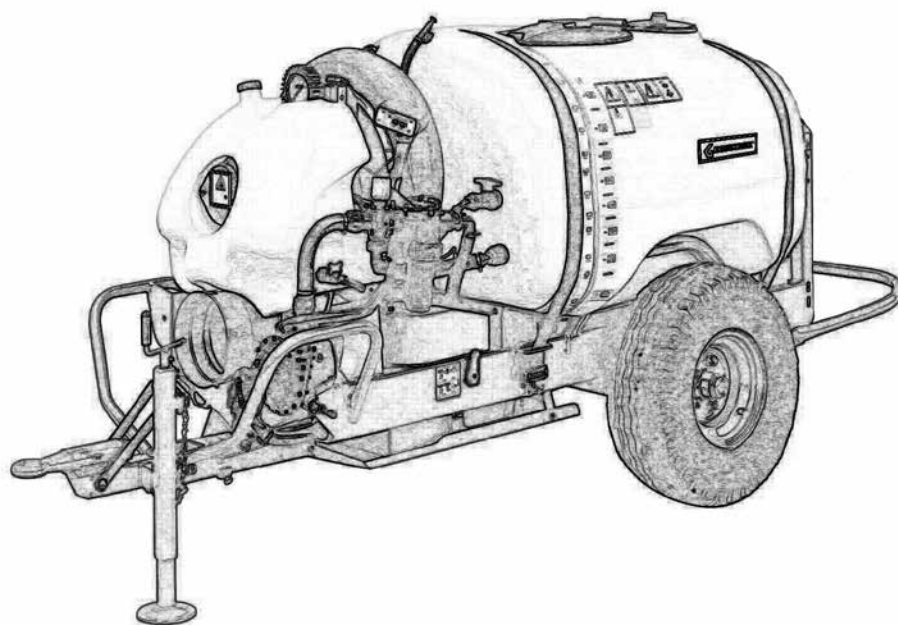

VENTURI AIR SPRAYERS



**Parts Manual For
Models T50S2-1200
300 Gallon Capacity**

Sept. 2020 Rev.1

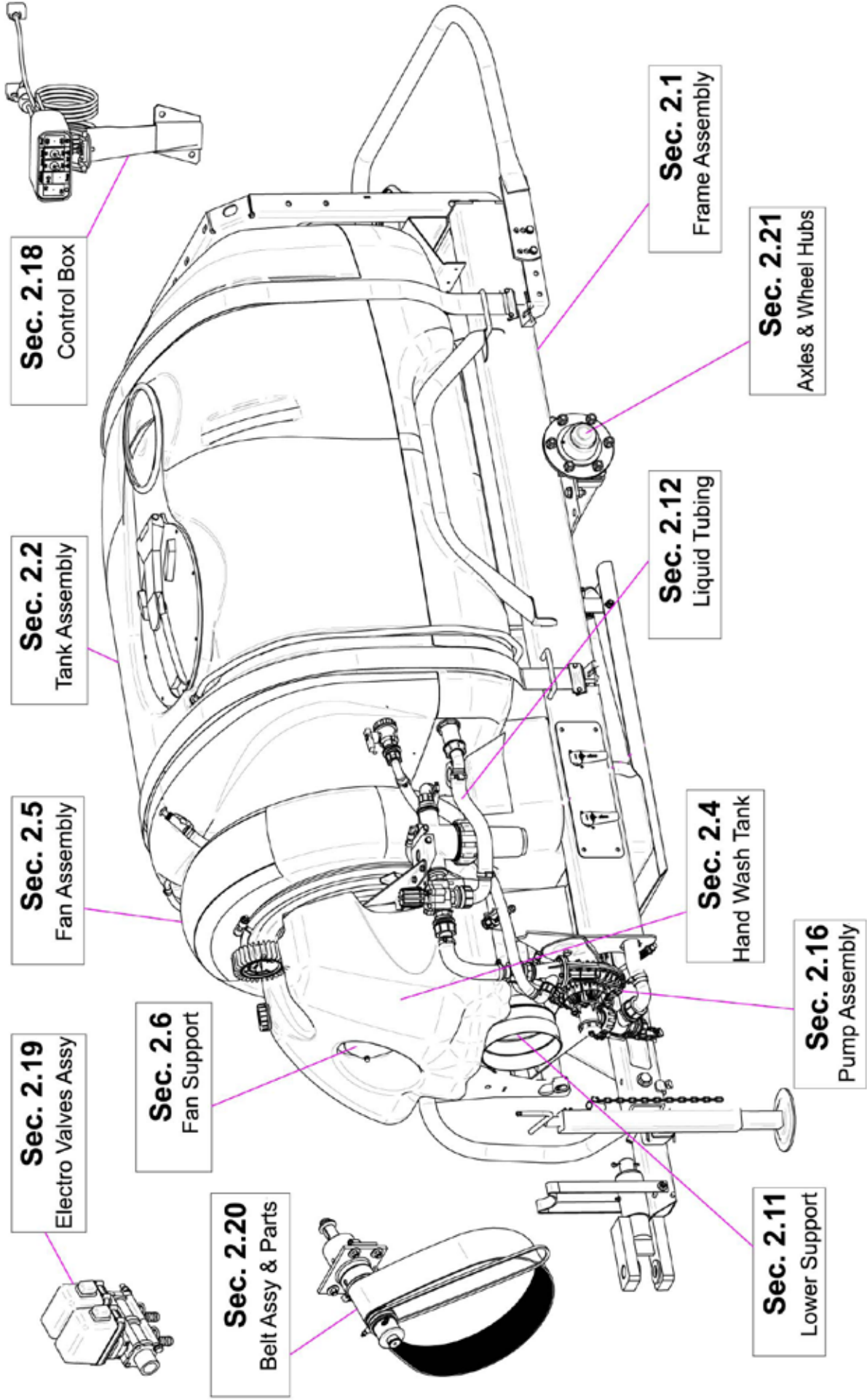

TABLE OF CONTENTS

<u>SECTION</u>	<u>DESCRIPTION</u>	<u>PAGE</u>
1	Introduction	1
1.1	Purchaser's Responsibility	1
1.2	Serial Number Information	1
2	Replacement Parts	2 - 39
2.1	Frame Assembly.....	2-4
2.2	Tank Assembly.....	5-6
2.3	Tank Fittings & Cover	7-8
2.4	Hand Wash Tank	9
2.5	Fan Assembly	10
2.6	Fan Support.....	11
2.7	Fan Support Breakdown.....	12
2.8	Belt Tension Roller.....	13
2.9	Lubrication Tubing.....	14
2.10	Main Pulley & Overrunning Clutch.....	15
2.11	Fan Support Hub Assy	16
2.12	Liquid Flow Path Manual Controls.....	17-19
2.13	Pumps & Routing.....	20-21
2.14	Pressure Regulator & 3Way Valve.....	22
2.15	Suction Filter Assembly.....	23
2.16	Main Pump Breakdown.....	24-25
2.17	Agitation Pump Breakdown.....	26-27
2.18	Control Box 910208/T.....	28
2.19	Electro Valves.....	29-30
2.20	Pump & Fan Belts	31
2.21	Axle & Wheel Hubs	32
2.22	Driveshaft	33-34
3	Limited Warranty	35

1 INTRODUCTION

This manual contains parts diagrams and replacement parts lists. Do not modify the equipment in any way. Unauthorized modification may impair the function and/or safety and could affect the life of the equipment.

It is the responsibility of the owner to make sure the machine is maintained properly, and that all parts are in working order.

Where replacement parts are necessary for periodic maintenance and servicing, genuine factory replacement parts ***MUST*** be used to restore your equipment to original specifications. The manufacturer will not be responsible for injuries or damages caused by use of unapproved parts and/or accessories.

The manufacturer reserves the right to make improvements to the machinery and parts at any time and at their discretion.

OPERATOR ORIENTATION - The directions left, right, front and rear, are as seen from the driver's seat and facing in the direction of travel.

1.1 PURCHASER'S RESPONSIBILITY

It is the responsibility of the purchaser and/or operator to.....

- Inspect the equipment and replace or repair any parts that are damaged or worn which under continued operation would cause damage, wear to other parts, or cause a safety hazard.
- Return the equipment or parts to the authorized dealer, from where it was purchased, for service or replacement of defective parts that are covered by warranty. (The factory may inspect equipment or parts before warranty claims are honored.)
- Payment of all costs incurred by the dealer for traveling to or transporting the equipment for warranty inspection and or claims.

1.2 MODEL / SERIAL NUMBER

NAME: _____

PURCHASED FROM: _____

DATE OF PURCHASE: _____

MODEL NUMBER: _____

SERIAL NUMBER: _____

2 REPLACEMENT PARTS

2.1 FRAME ASSEMBLY

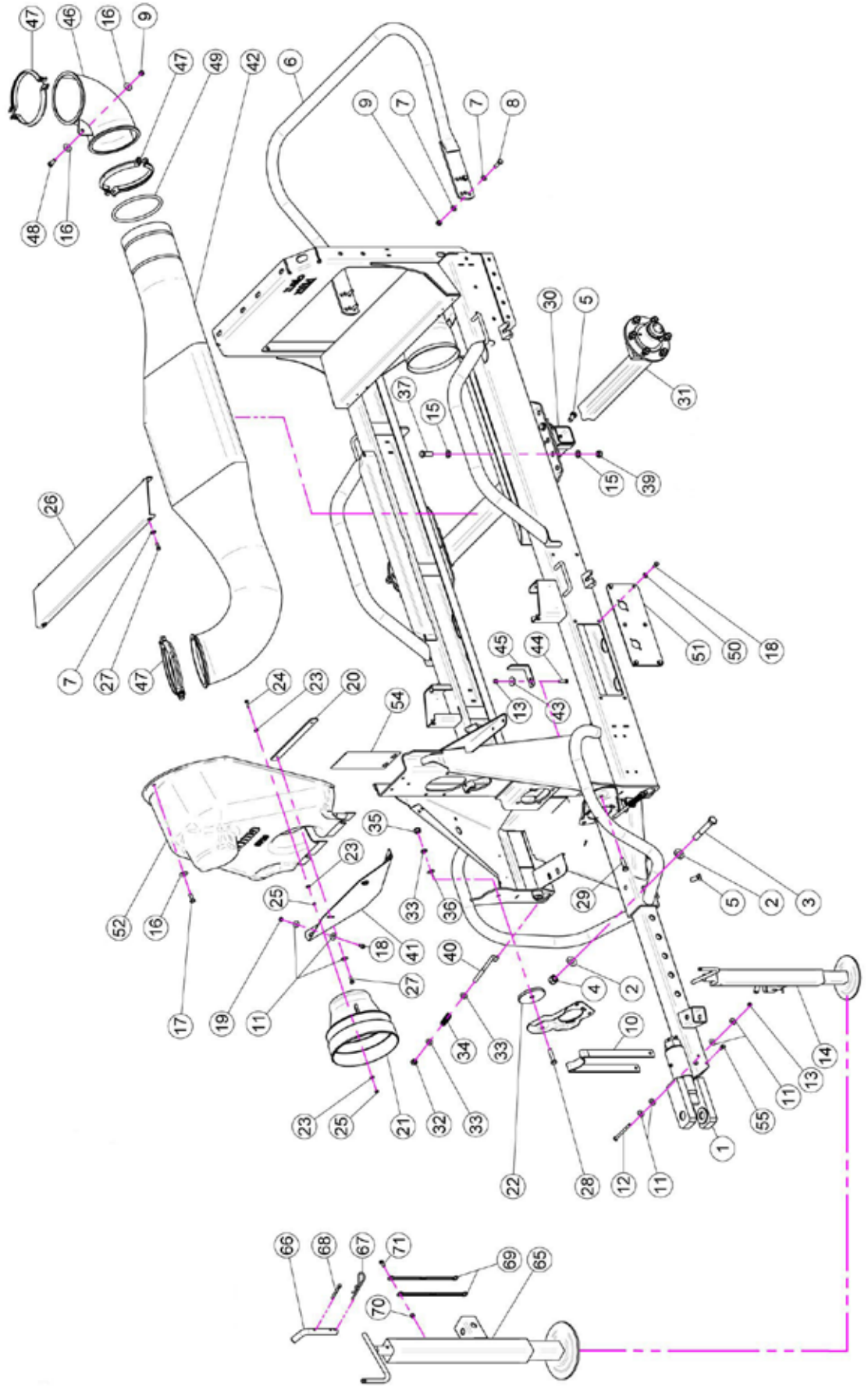

2.1 FRAME ASSEMBLY

<u>REF.</u>	<u>QTY.</u>	<u>PART NO.</u>	<u>DESCRIPTION</u>
1	1	40.136.200	Drawbar
2	2	RP.018.000	Washer
3	1	TE.018.120	Screw TE M18 x 120
4	1	DA.018.0AG	Self Locking Nut M18
5	6	TE.014.030T	Screw TE M14 x 30
6	1	40.146.100	Bumper
7	12	RP.010.000	Washer D.10
8	4	TE.010.035T	Screw TE 10 x 35
9	5	D0.10.5587G	Nut M10
10	1	20.409.000	Shaft Support
11	10	RP.008.024	Washer D.8 x 24
12	1	TE.008.100	Screw TE M8 x 100
13	2	DA.008.0AG	Self Locking Nut M8
14	1	04.993.070C	Extractable Jackstand
15	8	RP.014.000	Washer D.14
16	3	RP.010.030	Washer D.10 x 30 mm
17	1	TE.010.025T	Screw TE 10 x 25T
18	6	TE.008.020T	Screw TE 8 x 20
19	2	D0.08.5588G	Nut M8
20	1	20.532.000	Front Housing Blocking Plate
21	1	02.441.000	Shaft Cone D.240
22	1	20.533.100	Special Washer Ø100 SP 10 mm
23	9	RD.006.000	Tab Washer D.6
24	3	TE.006.025T	Screw TE M6 x 25
25	6	D0.06.5588G	Nut M6
26	1	40.302.200	Plate Tank Support
27	6	TE.008.025T	Screw TE M8 x 25
28	1	TE.012.050T	Screw M12 x 50T
29	1	TE.012.040T	Bolt TE M12 x 40
30	1	40.129.000	Axle
31	2	40.019.000	Hub 6
32	2	DOT.12.5587	M12 Brass Nut
33	6	RP.012.000	Washer D.12
34	2	02.964.000	CD32 Pump Spring
35	2	DA.012.0AG	Nut M12
36	2	MT.012.000	Washer D.12
37	4	TE.014.040T	Screw TE M14 x 40
38	2	02.978.000SX	Bracket
39	4	D0.14.5587G	Nut M14
40	2	20.447.000	Belt Stretcher For Pump
41	1	20.531.000	Carter Fixing Plate
42	1	40.122.100	Airway Tunnel
43	1	RP.008.032	Washer D.8 x 32
44	1	TE.008.030T	Screw TE M8 x 30
45	1	40.311.000	Bracket

2.1 FRAME ASSEMBLY

<u>REF.</u>	<u>QTY.</u>	<u>PART NO.</u>	<u>DESCRIPTION</u>
46	1	05.615.000	Elbow D.175 90°
47	3	05.616.000	Pipe Clamp D.175
48	1	TE.010.030T	Screw TE M10 x 30
49	1	40.147.000	Gasket For Tunnel 45-50
50	4	RP.008.000	Washer D.8
51	1	40.378.000	Protection Carter 3-Way Valve
52	1	05.723.160	Front Housing For 2 Pumps
54	1	50.355.000	Product Note Support
55	1	TE.008.016T	Bolt M8 x 16

TONGUE JACK

65	1	04.993.070	Jackstand Body
66	1	20.505.000	Pin Jackstand
67	1	00.100.004	Split Pin D.4
68	1	CP.006.040I	Pin D.6 Lg. 40
69	2	21.183.000	Cap Stop
70	1	D0.06.5588G	Nut M6
71	1	TE.006.016T	Screw TE M6 x 16

2.2 TANK ASSEMBLY

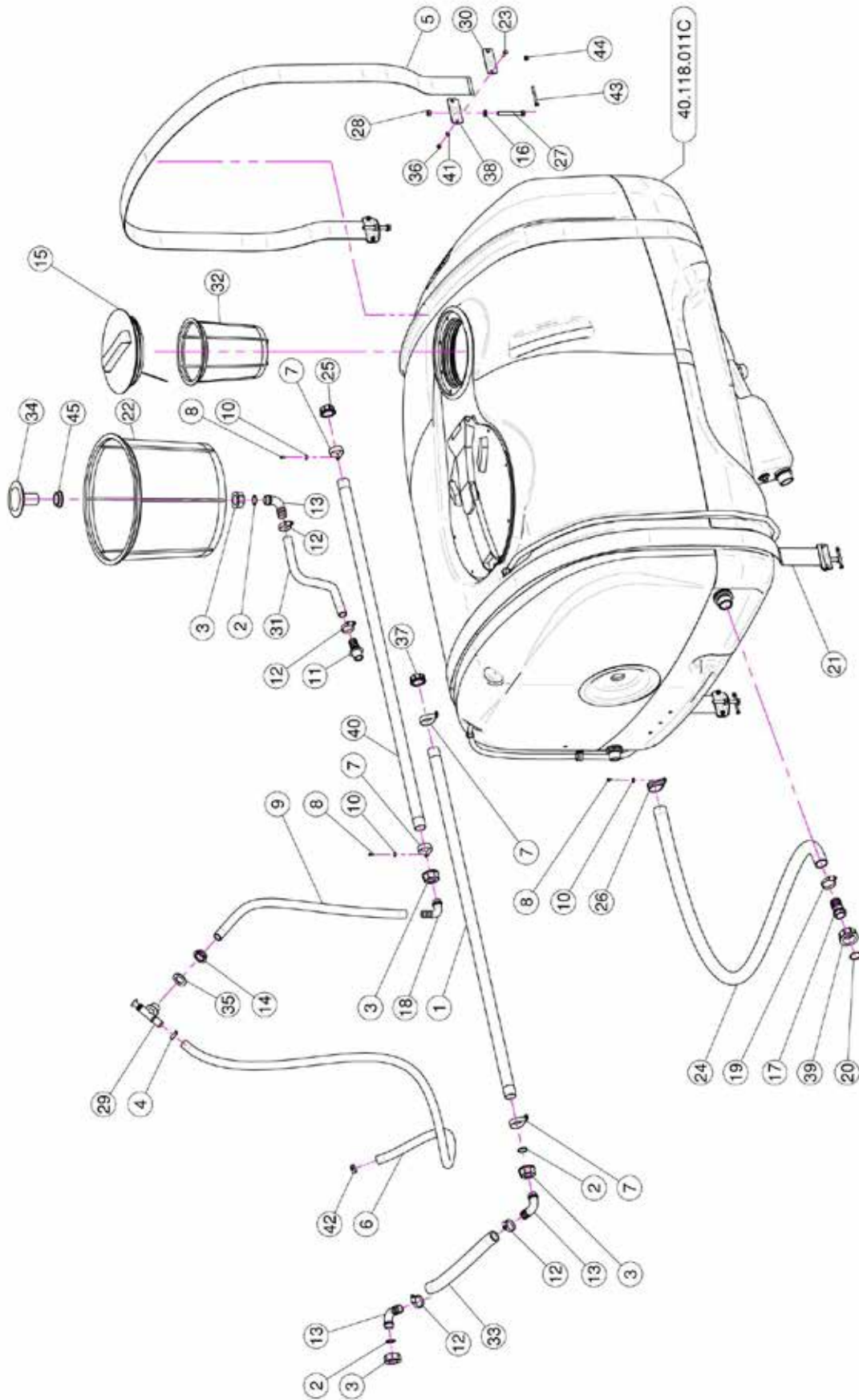

2.2 TANK ASSEMBLY

<u>REF.</u>	<u>QTY.</u>	<u>PART NO.</u>	<u>DESCRIPTION</u>
1	1	40.035.101	Perforated Hose 1" L=1200
2	3	OR.000.132	23.81 x 2.62 O-Ring Gasket
3	4	00.055.24.2	1" Fly Nut
4	1	FC.023.5.025	Hose Clamp 23.5 - 25
5	1	02.481.253	Nylon Band 60 mm L=2530
6	1	02.372.000	Hose D.19 L=1250 (Per Foot)
7	4	FN.035.000	Sticker
8	3	TE.005.010I	Screw TE M5 x 10
9	1	02.212.000	Hose D.19 x 26 L=750 (Per Foot)
10	3	RP.005.015I	Washer D.5 x 15
11	1	20.793.000	Hosetail R.H. D.25 3/4" GAS M.
12	4	F0.023.035I	Stainless Steel Clip
13	3	00.055.037	D.25 Hosetail
14	1	00.541.000	Nut 3/4"
15	1	02.476.100	Threaded Lid D.255 With Rope
16	4	RP.010.000	Washer D.10
17	1	00.058.028	Straight Hose R.H. D.30
18	1	00.055.038	Curved Union With R.H. D.19
19	1	F0.025.040I	Stainless Steel Clip
20	1	OR.003.112	O-Ring D.28.24 x 2.62
21	1	02.481.277	Nylon Band 60 mm L=2770
22	1	02.404.100	Basket Filter 400 x 330
23	8	TE.006.020T	Screw TE M6 x 20
24	1	02.238.000	Hose D.30 L=1200 (Per Foot)
25	1	TF.001.000	Packing
26	1	FG.040.000	Sticker
27	4	TE.010.080T	M10 x 80 Bolt
28	4	DOT.10.5587	M10 Brass Nut
29	1	02.135.000	Complete Piston Valve
30	4	20.513.000	Shaped Plate
31	1	20.809.000	Hose D.25 L=960 (Per Foot)
32	1	02.298.000	Basket Filter D.204
33	1	02.219.000	Hose D.25 L=300 (Per Foot)
34	1	00.055.034	Nipple 1"/1" GAS
35	1	00.131.000	1" Vortex Damper Drive
36	1	02.032.000	Gasket D.26 x 40 SP.2
37	8	DA.006.0AG	Self Locking Nut - High M6
38	1	TF.001.010	Packing
39	4	20.512.000	Bracket
40	1	00.373.000	1" GAS Sleeve
41	1	00.058.006	1" 1/4 Fly Nut
42	1	40.035.000	Perforated Hose 1" L=1200 (Per Foot)
43	8	RP.006.000	Washer D.6
44	1	FC.022.5.024	Hose Clamp 22.5 - 24
45	4	TE.006.060I	INOX M6 x 60 TE Screw
46	4	DC.06.5721I	Nut DIN 1587 6 x 1-6-10

2.3 TANK FITTINGS & COVERS

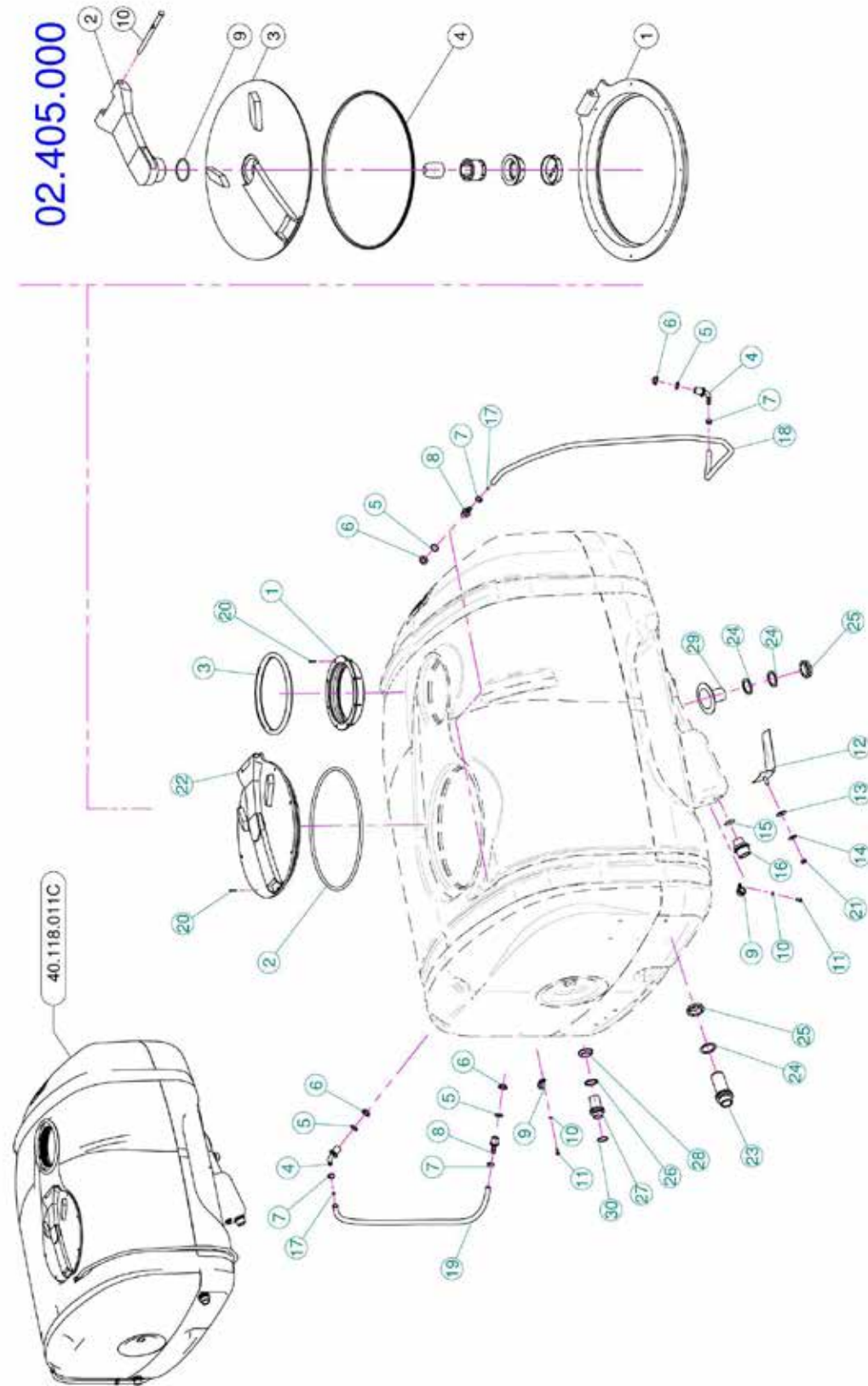

2.3 TANK FITTINGS & COVERS

<u>REF.</u>	<u>QTY.</u>	<u>PART NO.</u>	<u>DESCRIPTION</u>
1	1	02.477.000	Threaded Ring D.255
2	1	02.405.000.L	Gasket
3	1	02.477.000.A	Threaded Ring Gasket D.255
4	2	02.457.000	Hosetail D.13 90° M. 1/2"
5	4	OR.004.081	20.22 x 3.53 O-Ring Gasket
6	4	02.458.000	Lock Ring 1/2"
7	4	FC.016.5.018	Hose Clamp 16.5 - 18
8	2	02.482.000	Hosetail Male Threaded 1/2"
9	2	FG.018.000	Sticker
10	2	RP.006.000	Washer D.6
11	2	TE.006.016T	Screw TE M6 x 16
12	1	20.498.002	Stainless Steel Anti-Vortex
13	1	20.436.000	Special Garnishing For Anti-Whirl
14	1	RP.010.030	Washer D.10 x 30 mm
15	1	OR.000.507	27 x 5 O-Ring Gasket
16	1	00.045.012	1" 1/4 M - 1" M Reducer Nipple
17	2	02.478.000	Red Floating Ball D.8.5
18	1	02.378.160	Hose D.12 x 16 L=1600
19	1	02.378.085	Hose D.12 x 16 L=850
20	16	TAS.04.2.025I	Self Threaded Screw 4.2 x 25
21	1	DOT.10.5587	M10 Brass Nut
22	1	02.405.000	Hinged Tank Lid
23	1	00.345.000	Nipple 1" 1/4 + 1" 1/4 GAS
24	3	02.033.000	Gasket
25	2	00.543.000	Nut 1" 1/4 GAS
26	1	02.066.000	Gasket D.33 x 45
27	1	00.055.134.L	Cuttet Long Nipple 1"/1" GAS
28	1	00.542.000	Nut 1"
29	1	00.130.000	1" 1/4 Vortix Damper Drive
30	1	OR.004.118	29.75 x 3.53 O-Ring Gasket

02.405.000 MAIN HITCH

1	1	02.405.000.B	Base Ring
2	1	02.405.001	Arm
3	1	02.405.000.A	Gripping Plate
4	1	02.405.002	Shaped Gasket
9	1	OR.000.512	51 x 3.5 O-Ring Gasket
10	1	20.787.000.D	Pin

2.4 HAND WASH TANK

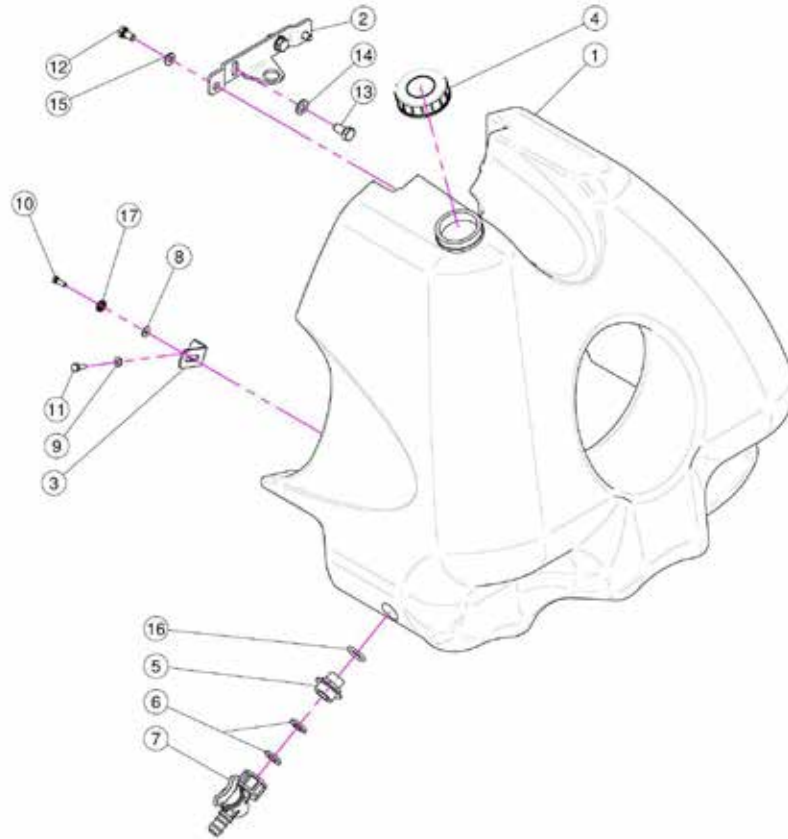

<u>REF.</u>	<u>QTY.</u>	<u>PART NO.</u>	<u>DESCRIPTION</u>
1	1	40.322.000	Hand Washing Tank
2	1	40.323.000	Fixing Bracket
3	2	40.324.100	Bracket
4	1	02.460.000	Female Threaded Tank Lid
5	1	00.055.044	Nipple 1/2" - 3/4" GAS
6	2	02.030.010	Gasket
7	1	02.497.000	3/4" Female Valve
8	2	RP.005.015I	Washer D.5 x 15
9	2	RP.006.000	Washer D.6
10	2	TE.005.016I	Screw TE M5 x 16
11	2	TE.006.016T	Screw TE M6 x 16
12	2	TE.008.016T	Screw TE M8 x 16
13	2	TE.010.020T	Screw TE M10 x 20
14	2	RP.010.000	Washer D.10
15	2	RP.008.000	Washer D.8
16	1	OR.004.081	20.22 x 3.53 O-Ring Gasket
17	2	RD.006.000	Tab Washer D.6

2.5 FAN ASSEMBLY

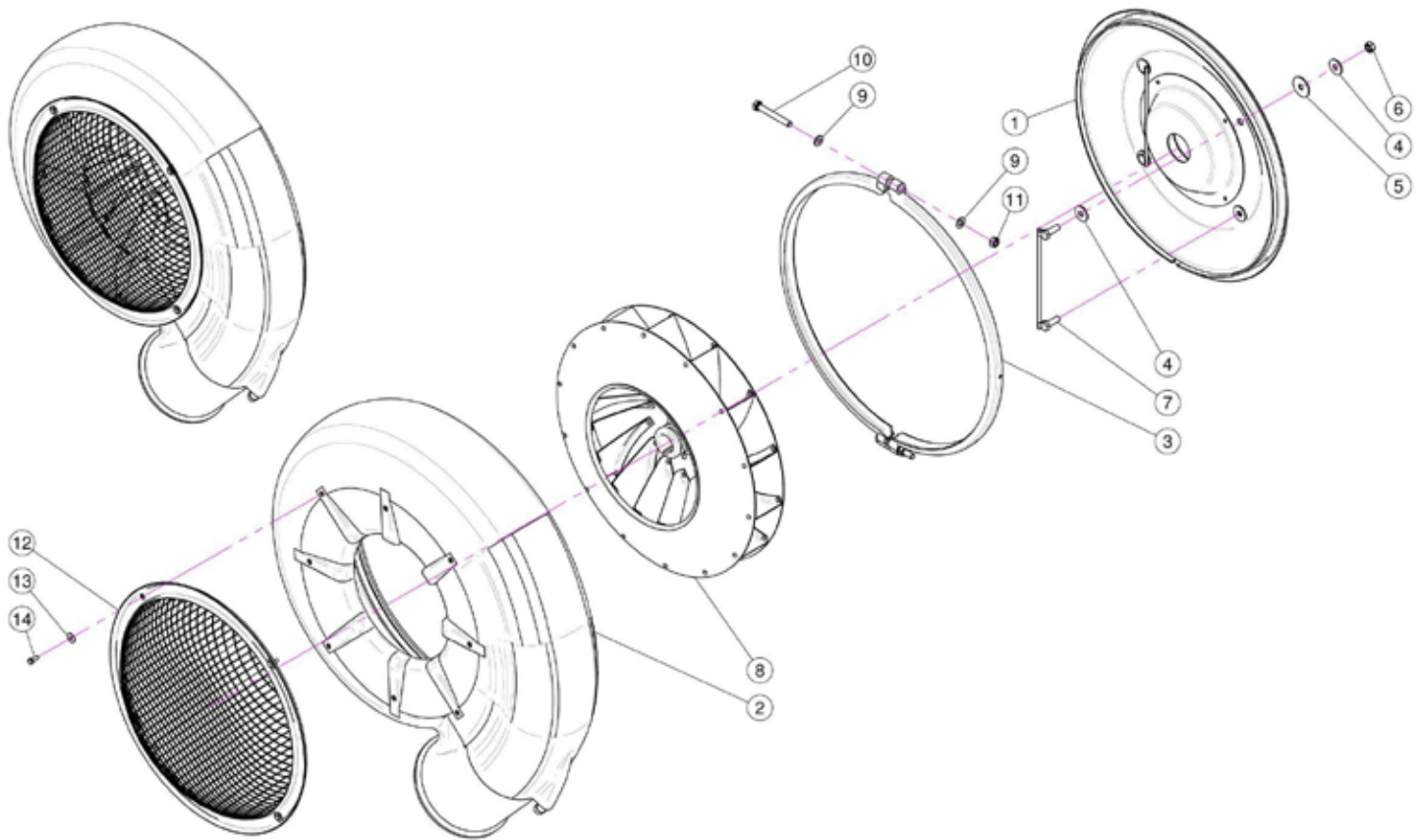

<u>REF.</u>	<u>QTY.</u>	<u>PART NO.</u>	<u>DESCRIPTION</u>
1	1	50.120.000	Fan 50 Cover
2	1	05.730.000	50 Fan Housing
3	1	05.731.000.Z	D.535 Clamp
4	8	RP.010.030	Washer D.10 x 30 mm
5	4	RP.010.040	Washer D.10 x 40
6	4	D0.10.5587G	Nut M10
7	2	20.088.000	Back Cover Bracket
8	1	05.732.000	Fan 50
9	4	RP.010.000	Washer D.10
10	2	TE.010.080T	Bolt M10 x 80
11	2	DOT.10.5587	M10 Brass Nut
12	1	05.654.200	Fan Net Protection
13	4	RP.006.018	Washer D.6 x 18
14	4	TE.006.016T	Screw TE M6 x 16

2.6 FAN SUPPORT

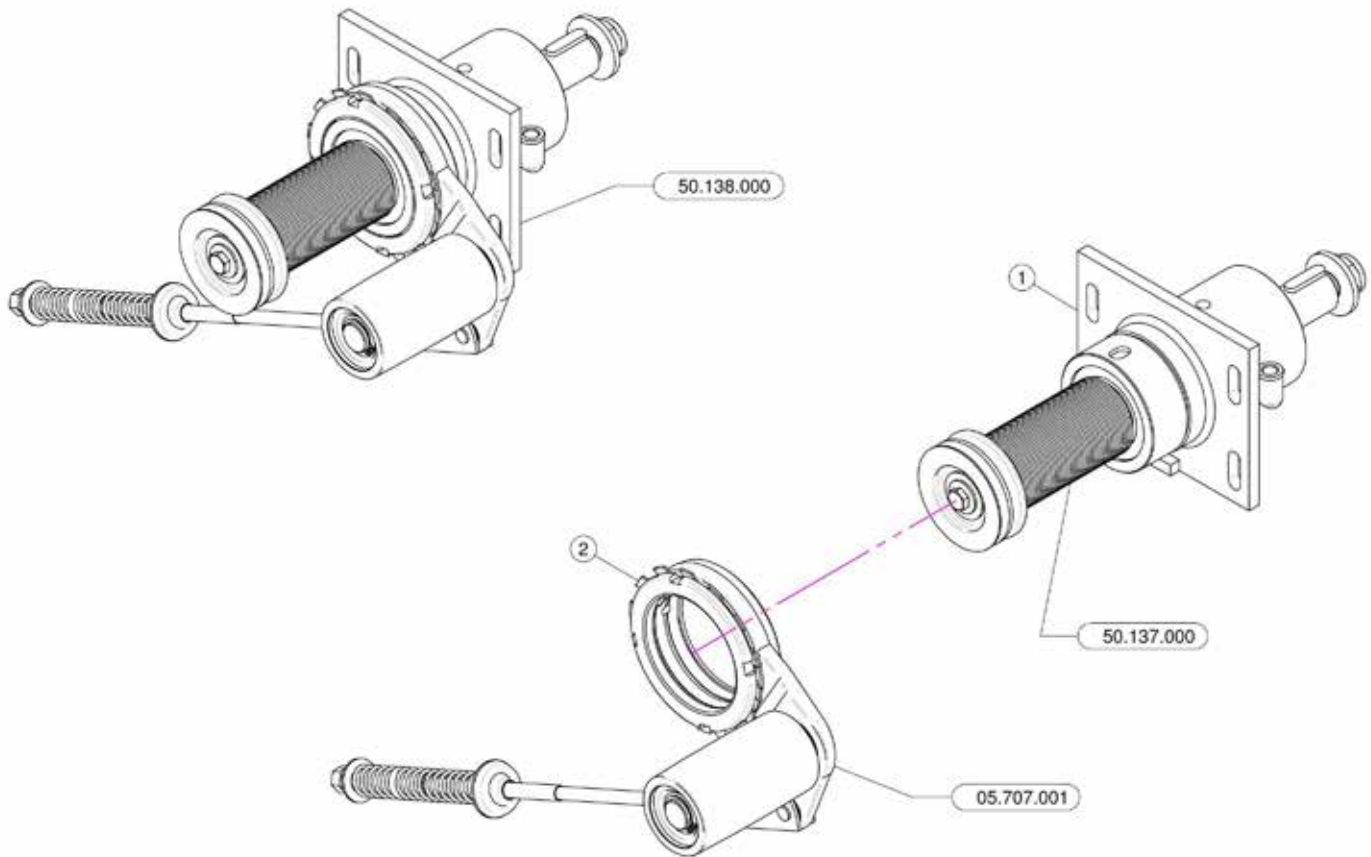

50.138.000 Super

<u>REF.</u>	<u>QTY.</u>	<u>PART NO.</u>	<u>DESCRIPTION</u>
1	1	50.137.000	Fan Support With Shaft
2	1	05.707.001	Automatic Belt Stretcher

2.7 FAN SUPPORT BREAKDOWN

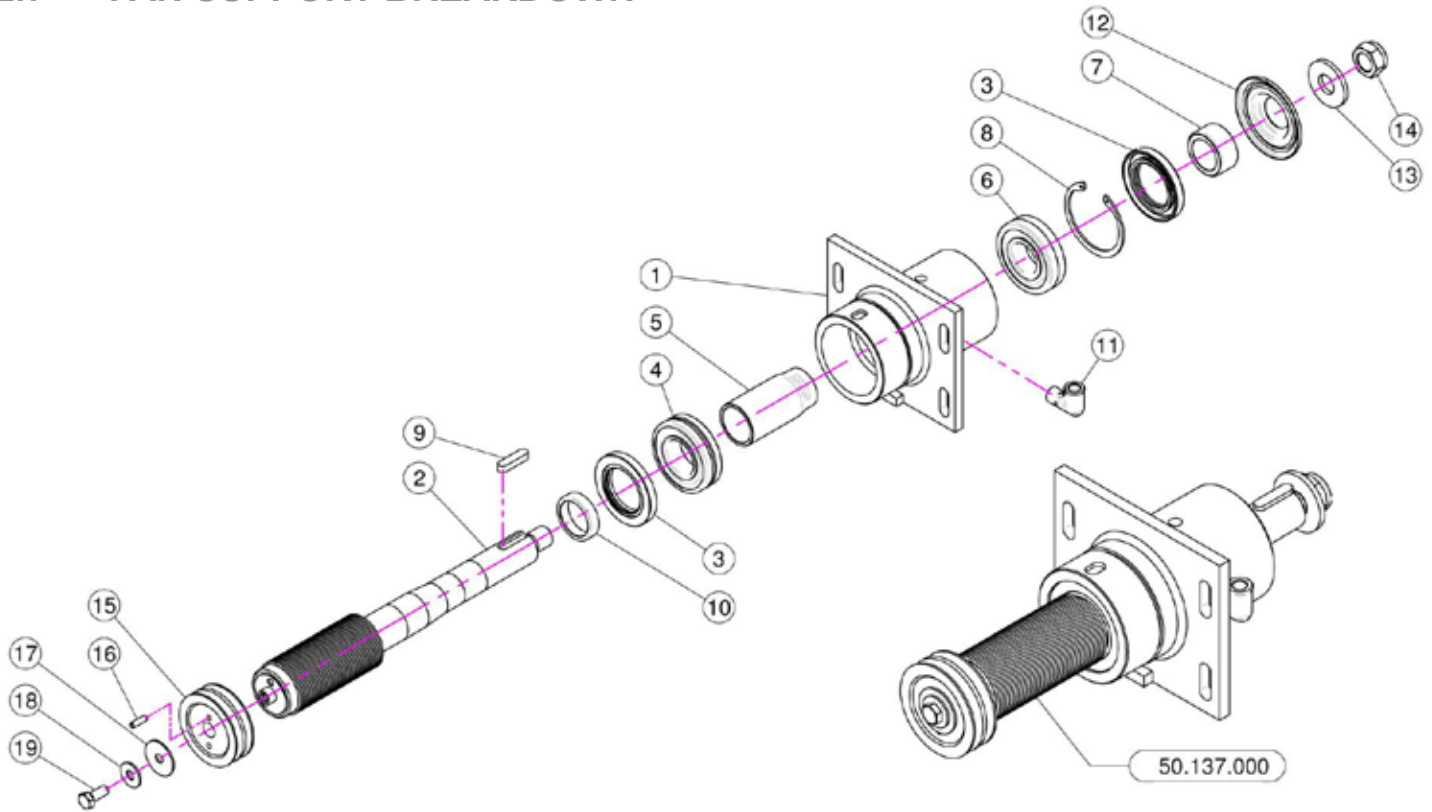

50.134.000

<u>REF.</u>	<u>QTY.</u>	<u>PART NO.</u>	<u>DESCRIPTION</u>
1	1	50.110.000	Nude Fan Support
2	1	50.119.060	Shaft With Pulley D.60
3	2	BASL.50.80.10	Viton Lip Seals - IEL (50-80-10)
4	1	K0.022.208	Roller Bearing 22208
5	1	50.112.000	Spacer
6	1	K0.021.307	Roller Bearing 21307
7	1	50.113.000	Spacer
8	1	10.080.000	Internal D.80 Circlip
9	1	L.10.08.40	Feather Key 10 x 8 x 40
10	1	50.114.000	Spacer
11	1	20.789.000	Male/Female 90° Elbow
12	1	50.115.000	Dust Cover
13	1	20.820.000	Washer
14	1	DA.022.0BF	Self Locking Nut M22 x 1.5
15	1	05.746.000	Pulley For Pump D.82 2 x 3V
16	1	SE.006.020	Spring Pin D.6 x 20
17	1	RP.010.040	Washer D.10 x 40
18	1	RP.010.028	Washer D.10 x 28
19	1	TE.010.025FT	Bolt TE M10 x 25

2.8 BELT TENSION ROLLER

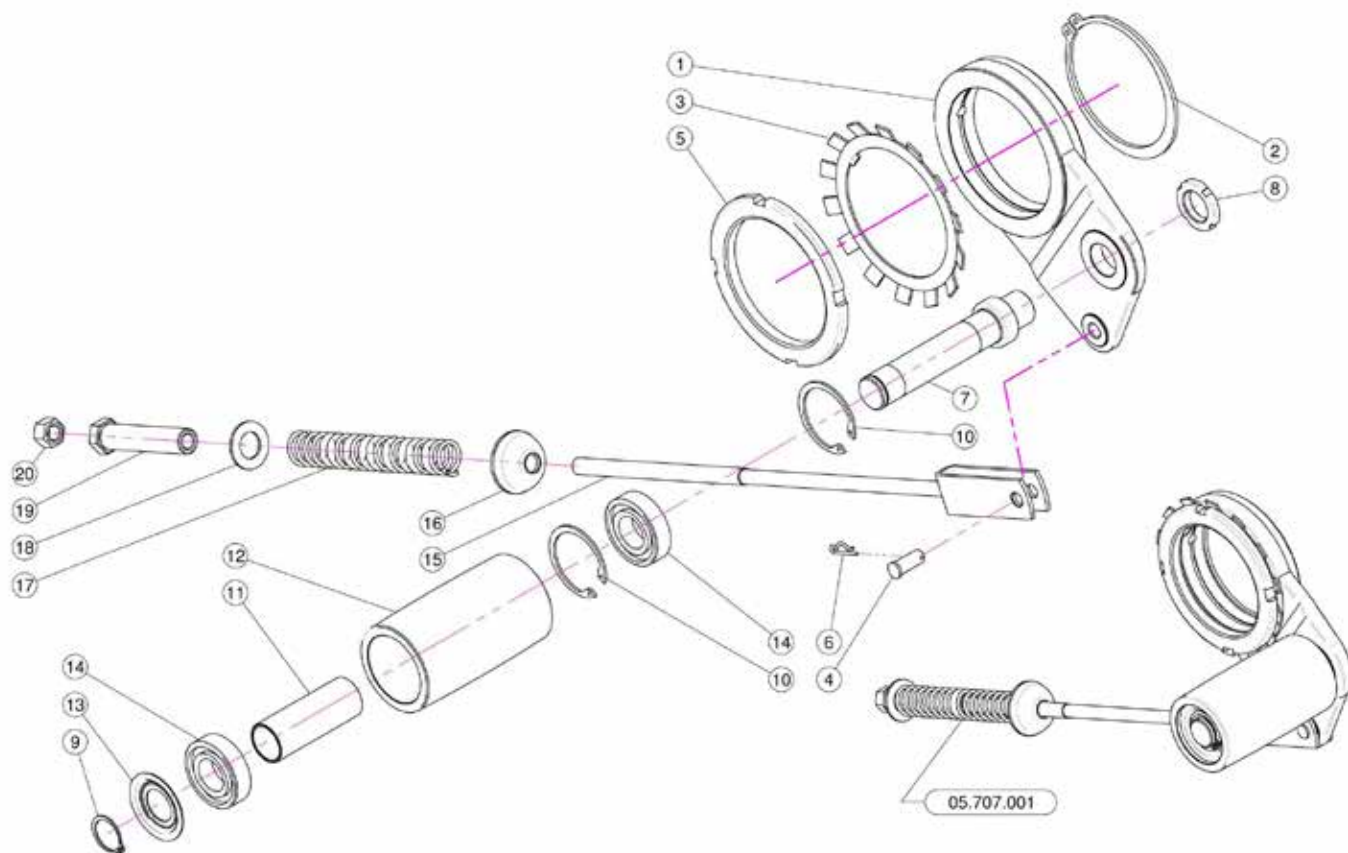

REF.	QTY.	PART NO.	DESCRIPTION
1	1	05.696.000	Idler Support
2	1	E0.100.000	External D.100 Circlip
3	1	MB.020.000	Tooth Lock Washer
4	1	04.593.000	Pin
5	1	05.704.000	Register Nut
6	1	00.100.002	Clip
7	1	05.697.000	Pivot
8	1	KM.005.000	Nut KM5
9	1	E0.025.000	External D.25 Circlip
10	2	I0.052.000	Internal D.52 Circlip
11	1	05.631.101	Spacer
12	1	05.630.000	Roller
13	1	04.585.000	Anti-Dust Cover
14	2	K6.205.2RS	Roller Bearing 6205-2RS
15	1	05.653.000	Belt Stretcher Fork
16	1	20.260.000	Special Washer D.12
17	1	04.093.000	Spring
18	1	RP.019.000	Washer D.19
19	1	04.583.000	Special Screw
20	1	D0.12.5587G	M12 Nut

2.9 LUBRICATION TUBING

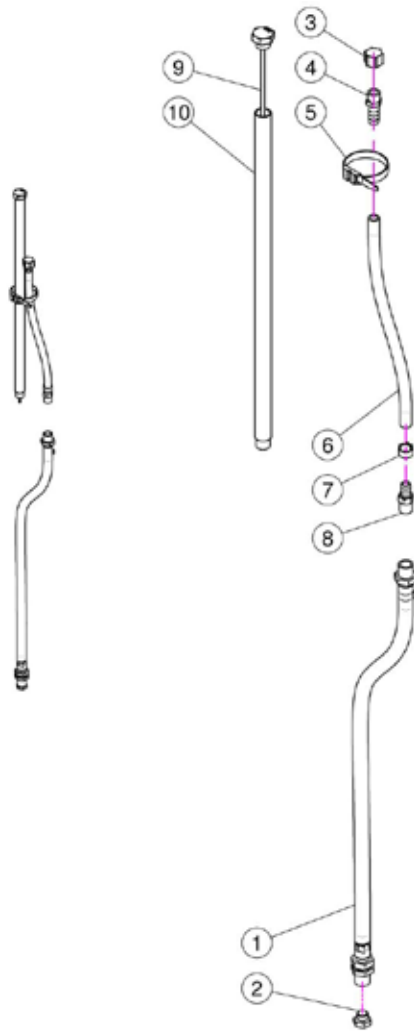

REF.	QTY.	PART NO.	DESCRIPTION
1	1	20.790.000	Drain Pipe 3/8"
2	1	40.266.000	Oil Exhaust Plug
3	1	02.013.000	Plug G1/4"
4	1	00.414.100	Straight Hose D.11 1/4" With Bleed
5	1	02.355.000	Nylon Assembly Clamp
6	1	02.217.000	Hose D.8 x 13 L=250 (Per Foot)
7	1	FC.014.5.016	Hose Clamp
8	1	20.792.000	Straight Hose D.11 G 1/4" For Breather
9	1	50.116.000	Filling Plug With Dipstick
10	1	50.122.000	Filling Pipe L=451

2.10 MAIN PULLEY & OVERRUNNING CLUTCH

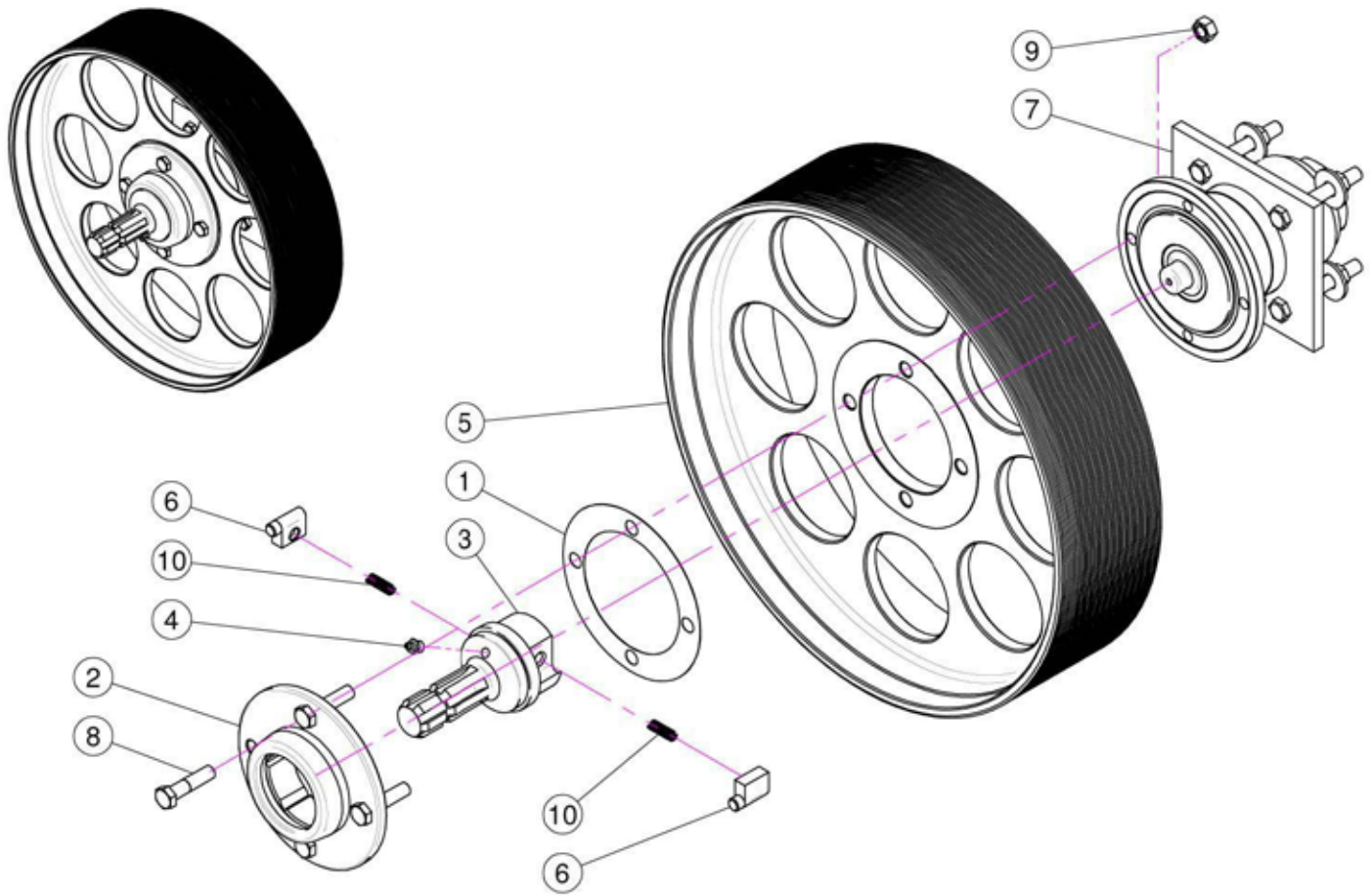

<u>REF.</u>	<u>QTY.</u>	<u>PART NO.</u>	<u>DESCRIPTION</u>
1	1	04.719.000	Gasket
2	1	04.066.000	Body
3	1	03.701.000	Rotor
4	1	ID.010.001	Grease Nipple
5	1	00.480.J50	Pulley Dia. 480 J 50
6	2	02.502.002	Pin
7	1	05.632.01C	Clutch
8	4	TE.012.050F	Bolt M12 x 50
9	4	D0.12.5587F	Nut M12 PG 5587F
10	2	02.502.001	Spring

2.11 FAN SUPPORT HUB ASSEMBLY

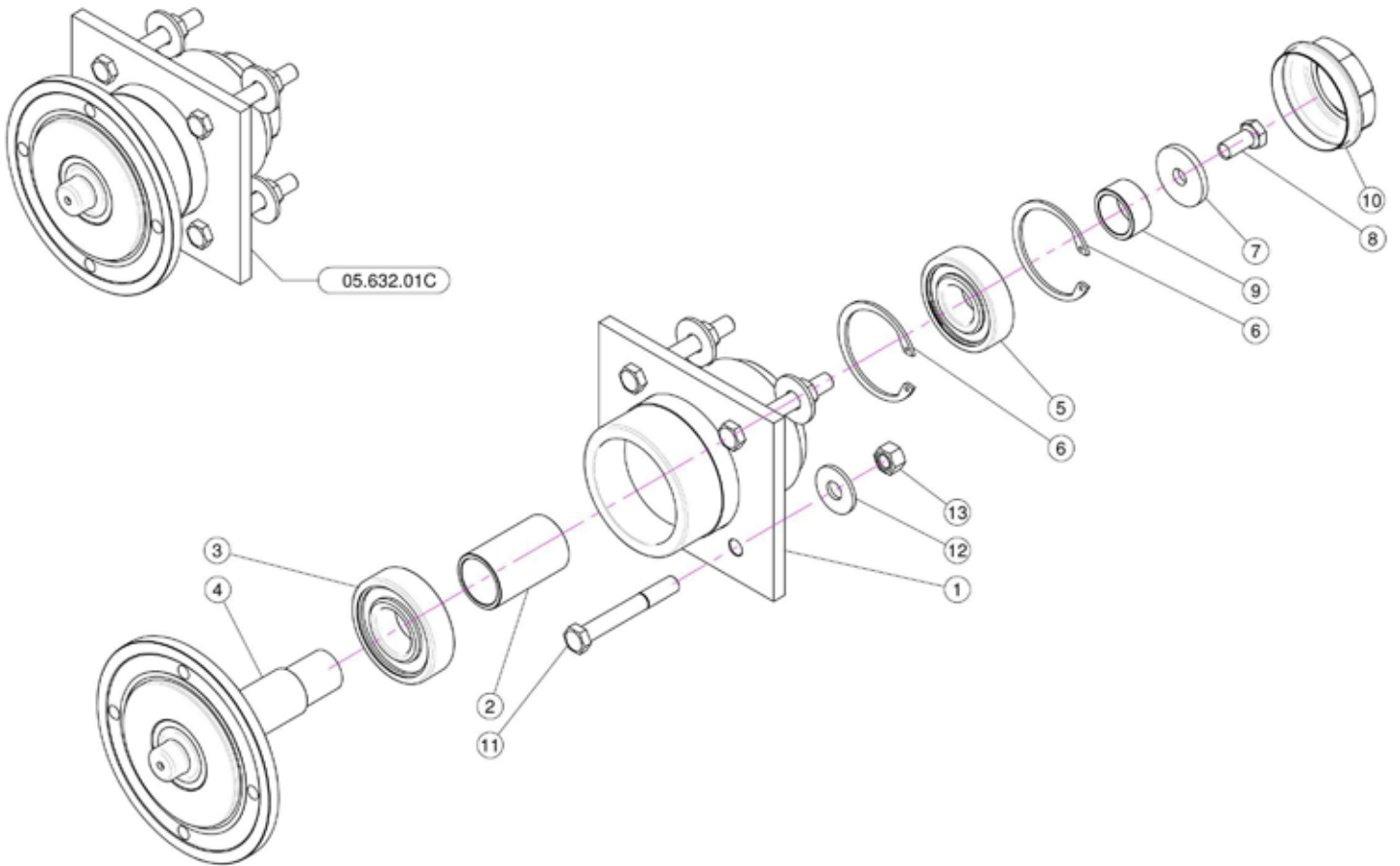

REF.	QTY.	PART NO.	DESCRIPTION
1	1	05.632.000	Lower Support
2	1	04.565.000	Lower Shaft Spacing Bar
3	1	K6.307.2RS	Bearing
4	1	04.589.000	Lower Shaft
5	1	K6.306.2RS	Bearing
6	2	I0.072.000	Spacing Bar
7	1	20.810.000	Special Washer For Lower Support
8	1	TE.012.025FT	Bolt TE M12 x 1.25
9	1	04.590.000	Spacer
10	1	04.555.001	Cover
11	4	TE.012.090	Screw TE M12 x 90
12	4	RP.012.036	Washer D12 x 36
13	4	D0.12.5587G	M12 Nut

2.12 LIQUID FLOW PATH

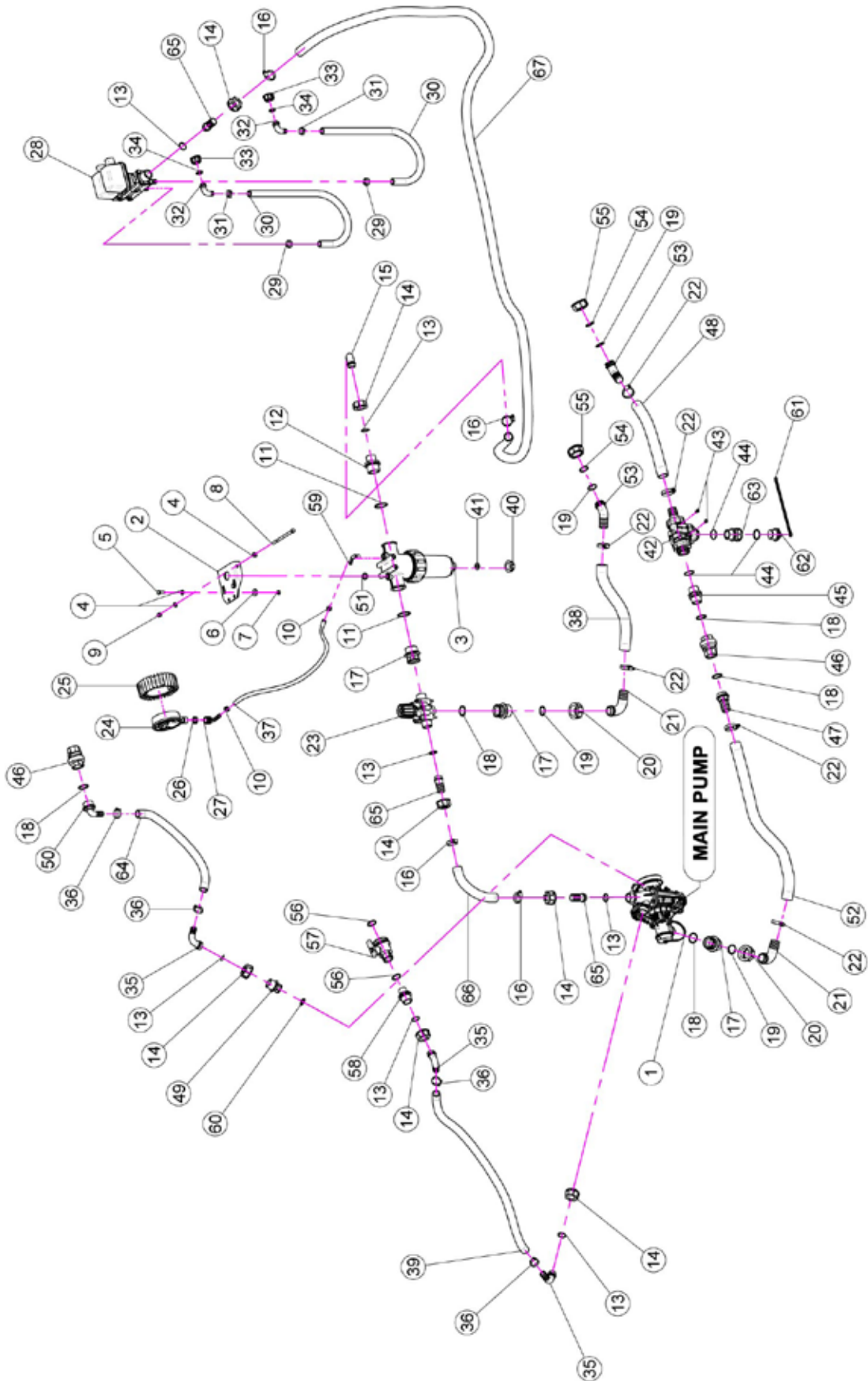

2.12 LIQUID FLOW PATH

<u>REF.</u>	<u>QTY.</u>	<u>PART NO.</u>	<u>DESCRIPTION</u>
1	1	02.157.071	Pump
2	1	20.519.100	Bracket
3	1	02.450.110	Line Filter 1" 1/4 Female
4	4	RP.008.000	Washer D.8
5	2	TE.008.025T	Screw TE M8 x 25
6	2	RP.008.024	Washer D.8 x 24
7	2	D0.08.5588G	M8 6S Big Lead Nut 5588
8	1	TE.008.130	Screw M8 x 130
9	1	DA.008.0AG	Self Locking Nut M8
10	2	FC.013.5.015	Hose Clamp
11	2	OR.000.144	O-Ring D.39.69 x 3.53
12	1	00.045.012	1" 1/4 M - 1" M Reducer Nipple
13	6	OR.000.132	23.81 x 2.62 O-Ring Gasket
14	6	00.055.24.2	1" Fly Nut
15	1	00.055.037	D.25 Hosetail
16	4	F0.023.035I	Stainless Steel Clip
17	3	02.374.000	M./F. 1" F/1" 1/4 M Reduction
18	4	OR.003.112	O-Ring D.28.24 x 2.62
19	2	00.058.006	1" 1/4 Fly Nut
20	6	F0.025.040I	Stainless Steel Clip
21	8	OR.004.118	29.75 x 3.53 O-Ring Gasket
22	2	00.058.004	D.30 Hosetail
23	1	02.447.000	3 Way Valve
24	1	02.445.000	Pressure Gauge Ø100 INOX 0-6 Bar
25	1	02.470.000	Pressure Gauge Guard
26	1	24.072.000	Brass Fly Nut 1/2"
27	1	21.012.000	D.12 Hosetail
28	1	02.390.08C	Electro Valves
29	2	00.055.021	Straight Hose R.H. D.25
30	2	FC.021.5.023	Hose Clamp 21.5 - 23
31	2	02.211.000	Hose D.16 L=1100 (Per Foot)
32	2	FC.023.5.025	Hose Clamp 23.5 - 25
33	2	00.055.046	Curved Union With R.H. D.17
34	2	00.055.045	3/4" Fly Nut
35	2	02.349.000	17 x 23 x 3 Flat Gasket
36	3	00.055.038	Curved Union With R.H. D.19
37	4	FC.027.5.029	Hose Clamp 27.08 - W8
38	1	21.058.300	Three Ways Valve
39	2	TA.006.012P	Screw M6 x 12
40	2	OR.002.125	31.47 x 1.78 O-Ring Gasket
41	1	00.055.034	Nipple 1" / 1" GAS
42	2	21.149.000	Valve 1" F-F.

2.12 LIQUID FLOW PATH

<u>REF.</u>	<u>QTY.</u>	<u>PART NO.</u>	<u>DESCRIPTION</u>
43	1	00.422.100	Male Connector RH 30 1" GAS
44	1	21.186.000	Reducer Nipple 1" M - 1/2" F
45	1	TM.014.000	Male Plug 1/4"
46	2	02.339.000	45° Hosetail
47	2	OR.003.106	O-Ring D.26.65 x 2.62
48	2	00.493.000	1" 1/4 Fly Nut
49	2	OR.000.134	O-Ring D.25.8 x 3.53
50	1	02.395.000	Valve 3/4" GAS F.F. Ball
51	1	02.293.000	1" M - 3/4" M Reducer Nipple
52	1	21.084.000	Hosetail 90° WES 8/R1/4
53	1	20.770.000	Hose D.25 x 32 L=2870 (Per Foot)
54	1	02.217.000	Hose D.8 x 13 L=400 (Per Foot)
55	1	02.238.000	Hose D.30 x 41 L=550 (Per Foot)
56	1	02.212.000	Hose D.19 x 28 L=1000 (Per Foot)
57	1	02.182.000	Female 3/4" Cap
58	1	02.030.010	Gasket
59	1	02.238.000	Hose D.30 x 38 L=500 (Per Foot)
60	1	02.238.000	Hose D.30 x 38 L=1200 (Per Foot)
61	1	21.193.000	Hosetail 90° 1" R.H.
62	1	02.212.000	Hose D.19 L=1000 (Per Foot)
63	1	OR.004.081	20.22 x 3.53 O-Ring Gasket
64	1	02.384.000	1" M - 1" F Reducer Nipple
65	2	21.183.000	Cap Stop
66	2	21.182.000	Packing 1" M
67	1	02.274.000	Female Tesse 1"
68	1	02.403.000	Straight Hose R.H. D.25 - 1"
69	1	OR.000.507	27 x 5 O-Ring Gasket
70	1	20.809.000	Hose D.25 x 32 L=260 (Per Foot)

2.13 PUMPS & ROUTING

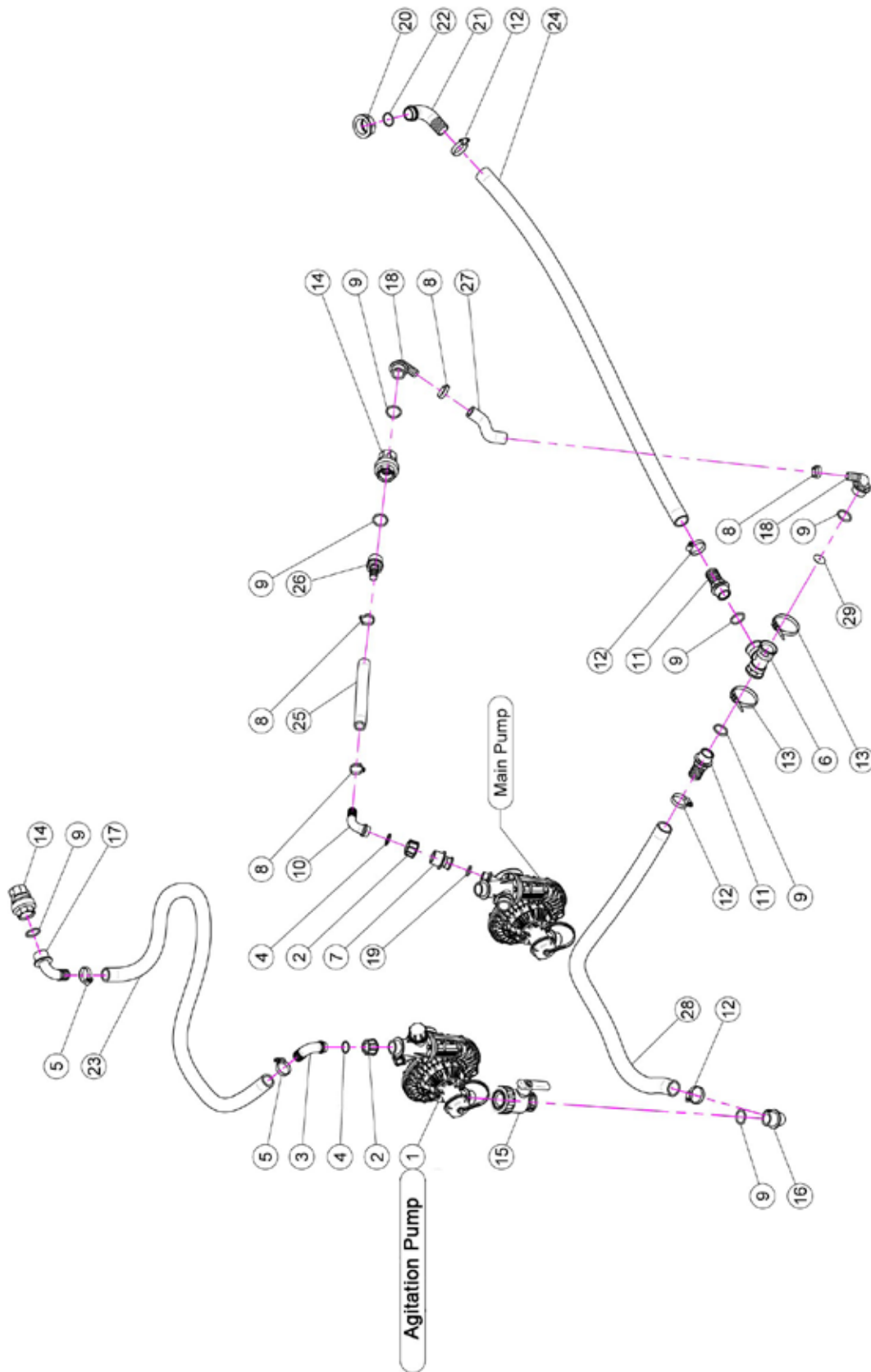

2.13 PUMPS & ROUTING

<u>REF.</u>	<u>QTY.</u>	<u>PART NO.</u>	<u>DESCRIPTION</u>
1	1	02.157.062	Pump
2	2	00.055.24.2	1" Fly Nut
3	1	00.055.037	D.25 Hosetail
4	2	OR.000.132	23.81 x 2.62 O-Ring Gasket
5	2	F0.023.035I	Stainless Steel Clip
6	1	02.274.000	Female Tesse 1"
7	1	21.186.000	Reducer Nipple 1" M - 1/2" F
8	4	FC.026.5.028	Hose Clamp 26.5 - 28
9	7	OR.004.118	29.75 x 3.53 O-Ring Gasket
10	1	00.055.038	Curved Union With R.H. D.19
11	2	00.422.000	Male Connector RH 30 1" GAS
12	4	F0.025.040I	Stainless Steel Clip
13	2	02.355.000	Nylon Assembly Clamp
14	2	21.149.000	Valve 1" F-F.
15	1	04.109.000	Two Ways Valve
16	1	00.465.000	Hosetail D.30 1" GAS
17	1	24.068.000	D.25 Hosetail
18	2	21.193.000	Hosetail 90° 1" R.H.
19	1	OR.004.081	20.22 x 3.53 O-Ring Gasket
20	1	00.493.000	1" 1/4 Fly Nut
21	1	00.058.004	D.30 Hosetail
22	1	OR.003.112	O-Ring D.28.24 x 2.62
23	1	20.809.000	Hose D.25 L=1400 (Per Foot)
24	1	20.852.000	Hose D.30 L=2000 (Per Foot)
25	1	02.212.000	Hose D.19 L=170 (Per Foot)
26	1	02.402.100	Straight Hose R.H. D.19 - 1"
27	1	02.212.000	Hose D.19 L=170 (Per Foot)
28	1	20.852.000	Hose D.30 L=1200 (Per Foot)
29	1	40.386.000	Washer w/Hole D.4 x Tee-Piece Union 2° Pump

2.14 PRESSURE REGULATOR & 3 WAY VALVE

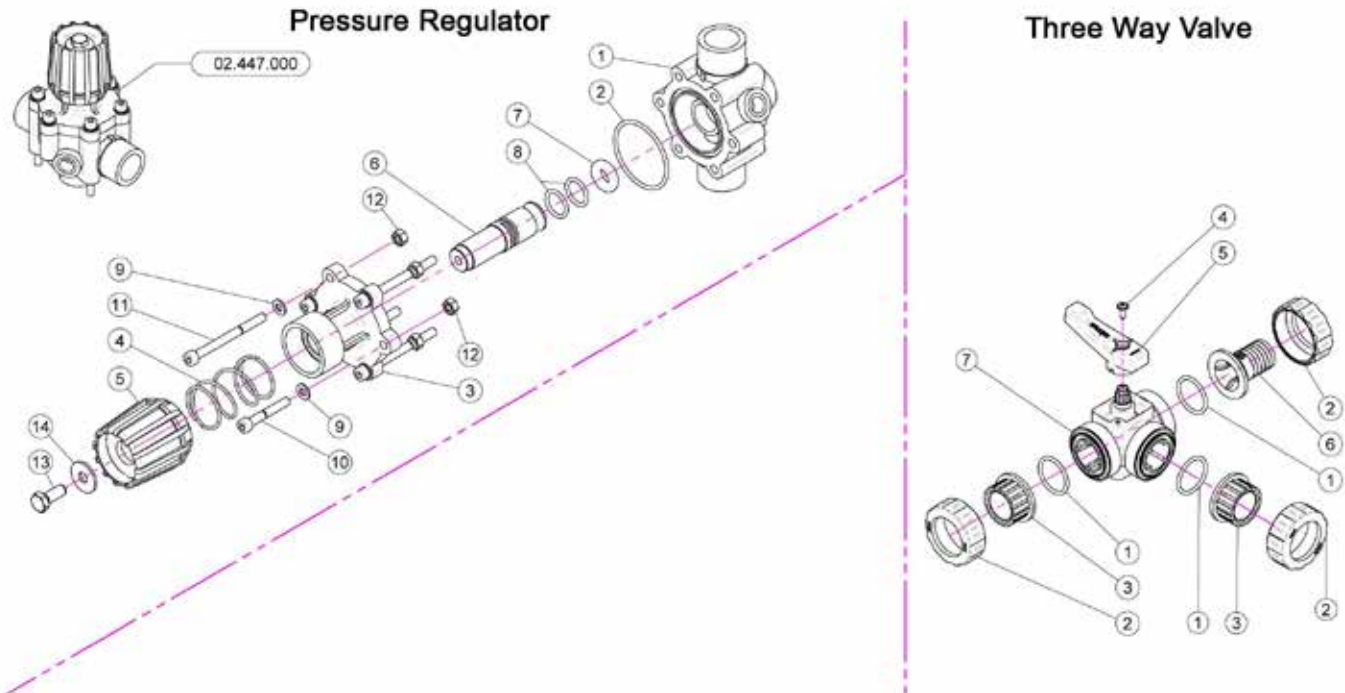

PRESSURE REGULATOR

<u>REF.</u>	<u>QTY.</u>	<u>PART NO.</u>	<u>DESCRIPTION</u>
-------------	-------------	-----------------	--------------------

1	1	02.447.001	Body For Regulator Valve
2	1	OR.003.193	O-Ring Gasket 48.89 x 2.62
3	1	02.447.009	Upper Flange
4	1	02.447.011	Spring
5	1	02.447.010	Regulation Valve Knob
6	1	02.447.014	Valve Pin
7	1	02.447.005	Special O-Ring For Gate 2447
8	2	OR.003.068	O-Ring Gasket 17.12 x 2.62
9	6	RP.006.000	Washer D.6
10	2	TCE.006.040	Bolt TCE M6 x 40
11	4	TCE.006.070	Bolt TCE M6 x 70
12	6	D0.06.5588G	Nut M6
13	1	TE.008.025I	INOX 8 x 25 Screw
14	1	RP.008.024I	INOX Washer D.8 x 24

3-WAY VALVE

1	3	OR.004.137	O-Ring D.34.52 x 3.53
2	3	21.058.007	Valve Union Nut
3	2	21.058.006	Valve End Connector
4	1	TA.05.5.016	Self Threaded Screw M5.5 x 16
5	1	21.058.003	Valve Handle
6	1	21.058.009	Rubber Holder D.30
7	1	21.058.110	Body of Three Way Valve

2.15 SUCTION FILTER ASSEMBLY

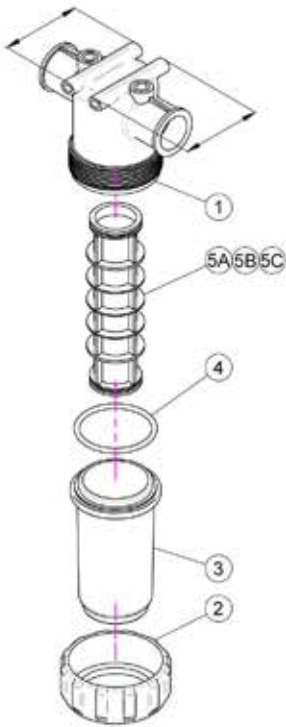

02.450.010

<u>REF.</u>	<u>QTY.</u>	<u>PART NO.</u>	<u>DESCRIPTION</u>
1	1	02.450.001	Line Filter Body
2	1	02.450.003	Ring Nut Filter In Line
3	1	02.450.011	Lid Filter With Unloading
4	1	OR.000.178	O-Ring D.74.63 x 5.33
5A	1	02.450.004C	Cartridge w/ O-Ring 50 Mesh (Blue)
5B	1	02.450.204C	Cartridge w/ O-Ring 80 Mesh (Grey)
5C	1	02.450.104C	Cartridge w/ O-Ring 32 Mesh (White)

2.16 MAIN PUMP BREAKDOWN

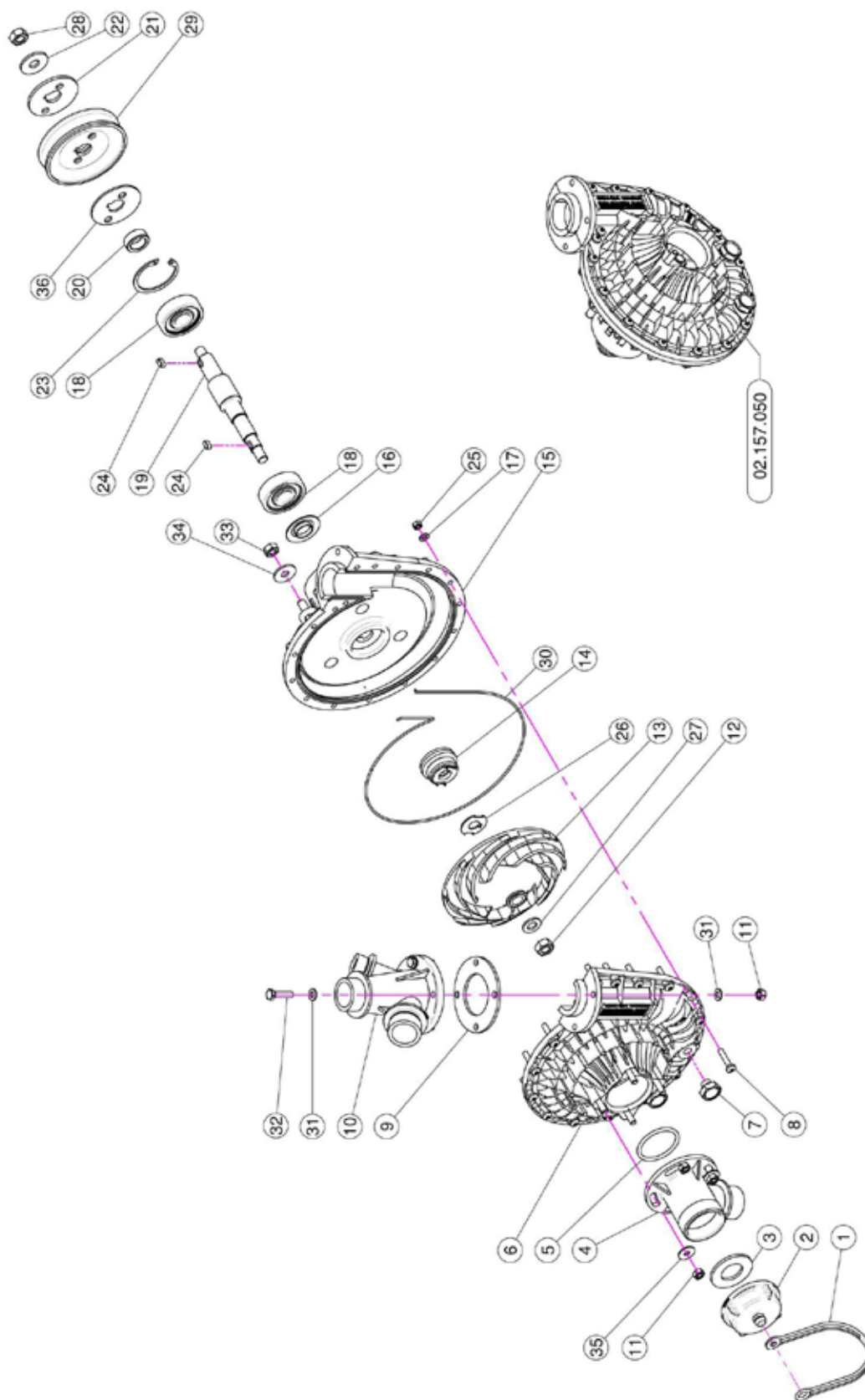

2.16 MAIN PUMP BREAKDOWN

<u>REF.</u>	<u>QTY.</u>	<u>PART NO.</u>	<u>DESCRIPTION</u>
1	1	21.183.000	Cap Stop
2	1	02.120.000	Rapid Thread Cap
3	1	02.130.000	24 x 46 x 3 Rubber Gasket
4	1	02.116.000	Suction Fitting
5	1	OR.000.144	O-Ring D.39.69 x 3.53
6	1	02.152.010	Housing
7	2	TM.010.015	M10 x 1.5 Cap
8	17	TC.05.25.85	Cross Slotted Screw M5 x 25
9	1	02.179.000	Rubber Gasket
10	1	02.113.000	Delivery Fitting
11	8	DOT.06.5587	M6 Brass Nut 5587
12	1	DOT.10.5587	M10 Brass Nut
13	1	02.153.000	CD32 Pump Impeller
14	1	00.085.024CS	Mechanical Seal
15	1	02.151.010	Pump Casing
16	1	20.406.000	Special Cover For Pump
17	17	RP.005.000	Washer D.5
18	2	K6.303.2RS	Roller Bearing
19	1	02.155.010	CD32 Pump Shaft
20	1	02.722.000	Bush
21	1	02.723.001	Special Washer 3 mm
22	1	RP.010.030	Washer D.10 x 30 mm
23	1	I0.047.000	Internal D.47 Circlip
24	2	L.05.05.10	5 x 5 x 10 Tang
25	17	DOT.05.5587	M5 Brass Nut (5587)
26	1	02.114.000	INOX Special Washer
27	1	RP.010.00I	Washer D.10 INOX
28	1	D0.10.5588G	M10 6S Big Lead Nut 5588
29	1	02.723.002	Pulley For Pump D.88 x 1 3 V
30	1	OR.C02.070	OR Cord D.2 L=700
31	8	RP.006.000	Washer D.6
32	4	TE.006.025T	Screw TE M6 x 25
33	3	D0.08.5588G	M8 6S Big Lead Nut 5588
34	3	RP.008.024	Washer D.8 x 24
35	3	RP.006.018	Washer D.6 x 18
36	1	02.723.005	Special Washer 2 mm

2.17 AGITATION PUMP BREAKDOWN

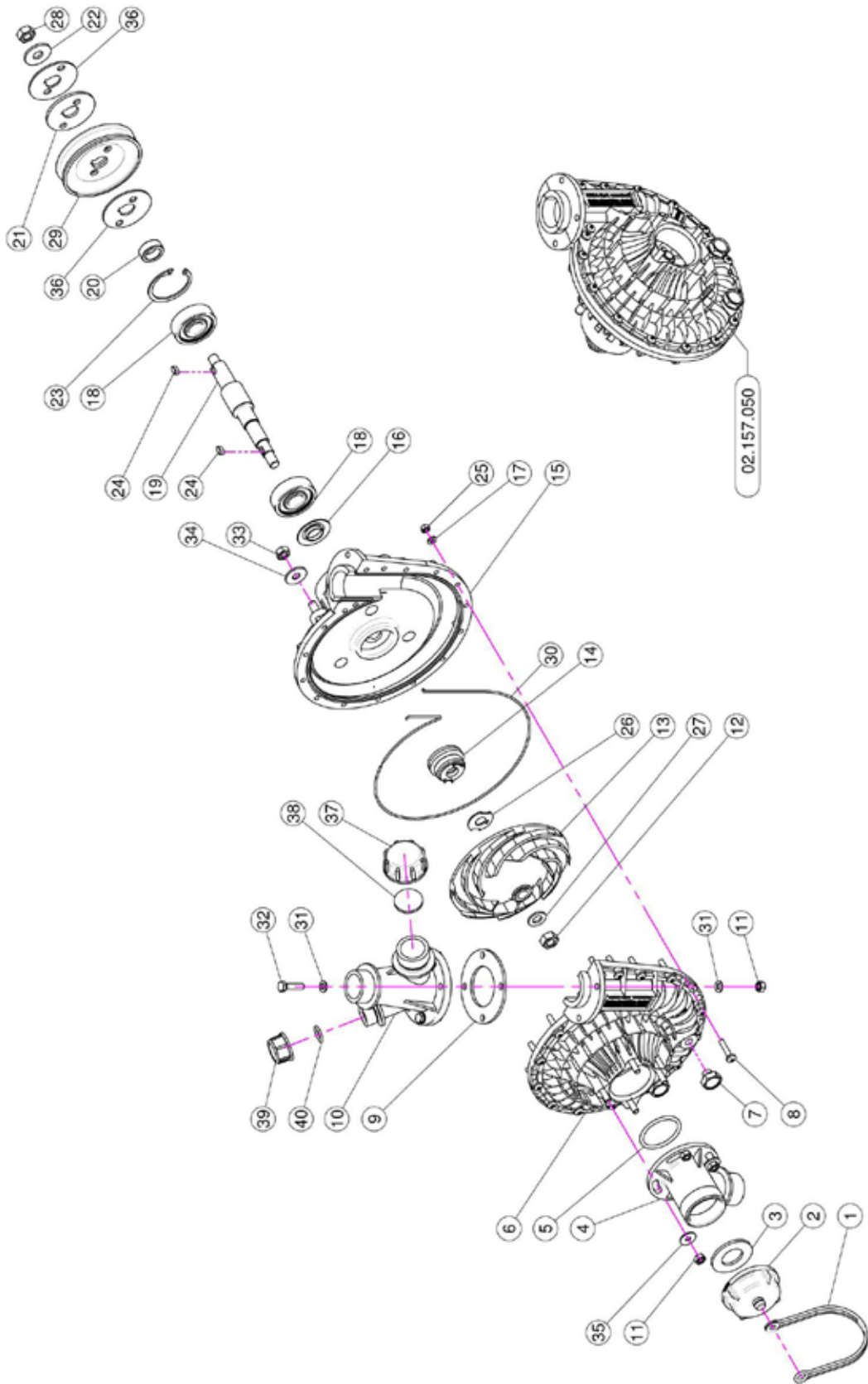

2.17 AGITATION PUMP BREAKDOWN

<u>REF.</u>	<u>QTY.</u>	<u>PART NO.</u>	<u>DESCRIPTION</u>
1	1	21.183.000	Cap Stop
2	1	02.120.000	Rapid Thread Cap
3	1	02.130.000	24 x 46 x 3 Rubber Gasket
4	1	02.116.000	Suction Fitting
5	1	OR.000.144	O-Ring D.39.69 x 3.53
6	1	02.152.010	Housing
7	2	TM.010.015	M10 x 1.5 Cap
8	17	TC.05.25.85	Cross Slotted Screw M5 x 25
9	1	02.179.000	Rubber Gasket
10	1	02.113.000	Delivery Fitting
11	8	DOT.06.5587	M6 Brass Nut 5587
12	1	DOT.10.5587	M10 Brass Nut
13	1	02.153.000	CD32 Pump Impeller
14	1	00.085.024CS	Mechanical Seal
15	1	02.151.010	Pump Casing
16	1	20.406.000	Special Cover For Pump
17	17	RP.005.000	Washer D.5
18	2	K6.303.2RS	Roller Bearing
19	1	02.155.010	CD32 Pump Shaft
20	1	02.722.000	Bush
21	1	02.723.001	Special Washer 3 mm
22	1	RP.010.030	Washer D.10 x 30 mm
23	1	I0.047.000	Internal D.47 Circlip
24	2	L.05.05.10	5 x 5 x 10 Tang
25	17	DOT.05.5587	M5 Brass Nut (5587)
26	1	02.114.000	INOX Special Washer
27	1	RP.010.00I	Washer D.10 INOX
28	1	D0.10.5588G	M10 6S Big Lead Nut 5588
29	1	02.723.000	Pulley For Pump D.82.5 x 1 3 V
30	1	OR.C02.070	OR Cord D.2 L=700
31	8	RP.006.000	Washer D.6
32	4	TE.006.025T	Screw TE M6 x 25
33	3	D0.08.5588G	M8 6S Big Lead Nut 5588
34	3	RP.008.024	Washer D.8 x 24
35	3	RP.006.018	Washer D.6 x 18
36	2	02.723.005	Special Washer 2 mm
37	1	TF.001.000	Packing
38	1	24.100.000	Gasket D.30 x 3
39	1	TF.012.000	Blank Cap 1/2"
40	1	OR.000.117	13.1 x 18.34 x 2.62 O-Ring Gasket

2.18 CONTROL BOX 910208/T

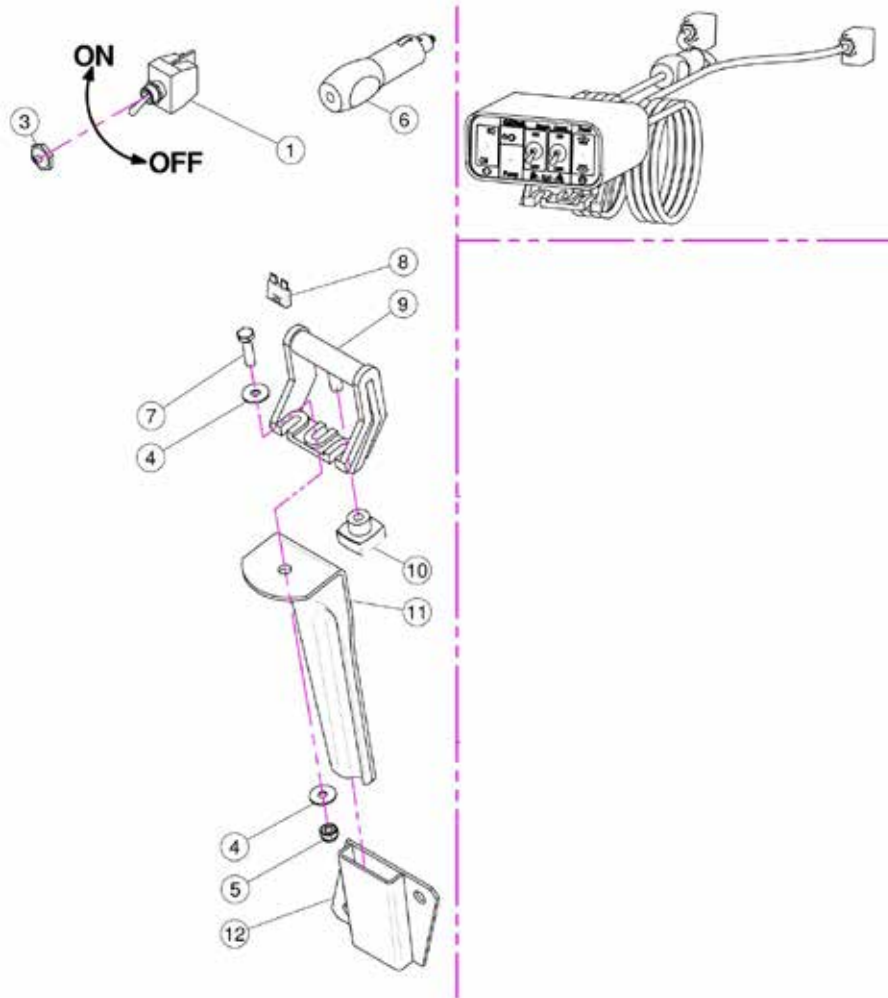

REF.	QTY.	PART NO.	DESCRIPTION
1	2	21.030.005	Switch 2V 2P On-Off 10A
3	2	21.030.007	Switch Cap D.12
4	2	RP.006.018	Washer D.6 x 18
5	1	DA.006.0AG	Self Locking Nut - High M6
6	1	21.030.008	12V Power Jack
7	1	TE.006.025T	Screw TE M6 x 25
8	1	21.030.004	10 Ah Fuse
9	1	21.030.002	Moving Fixing Bracket
10	1	21.030.003	Fixing Knob
11	1	20.111.000	Bracket
12	1	20.107.000	Female Bayonet Support

2.19 ELECTRO VALVES

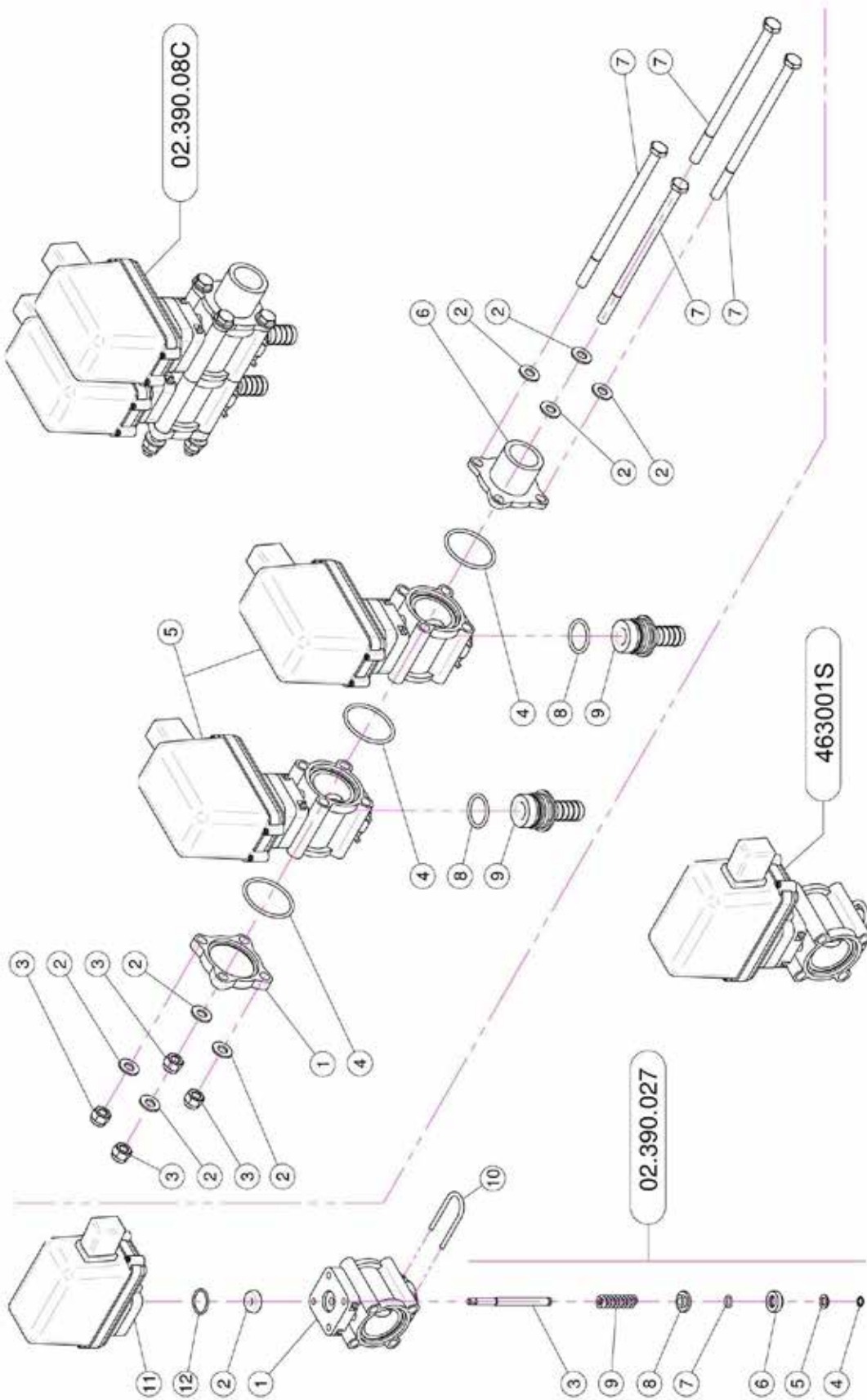

2.19 ELECTRO VALVES

02.390.029

<u>REF.</u>	<u>QTY.</u>	<u>PART NO.</u>	<u>DESCRIPTION</u>
1	1	02.390.007	Valve Body
2	1	02.390.008	Gasket
3	1	02.390.020	Pin
4	1	02.390.013	Stop Ring
5	1	02.390.014	Washer 7.2 x 12 INOX
6	1	02.390.015	Lower Valve
7	1	02.390.016	O-Ring
8	1	02.390.009	Superior Valves
9	1	02.390.011	Spring
10	1	21.130.005	Fork
11	1	02.390.028	Solenoid Valve
12	1	OR.002.075	D.18.77 x 1.78 O-Ring

02.390.08C

1	1	02.390.017	Valve Flange
2	8	RP.008.000	Washer D.8
3	4	DA.008.0AG	Self Locking Nut M8
4	3	OR.003.156	O-Ring Gasket 39.34 x 2.62
5	2	02.390.029	Solenoid Valve
6	1	02.390.018	Connector
7	4	TE.008.150	Screw TE M8 x 150
8	2	OR.000.130	22.22 x 2.62 O-Ring Gasket
9	2	02.406.000	Hosetail D.16

2.20 PUMP & FAN BELTS

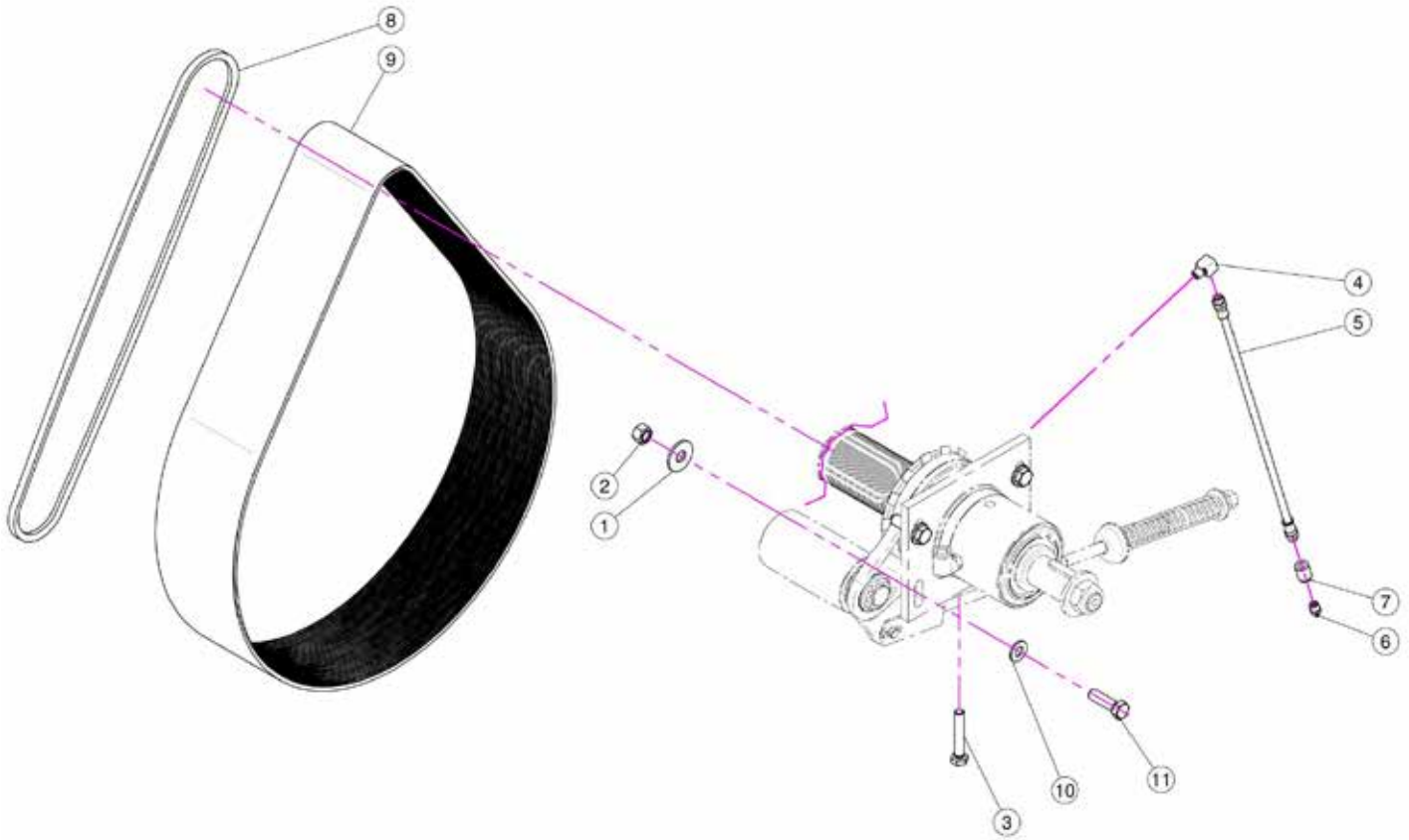

REF.	QTY.	PART NO.	DESCRIPTION
1	4	RP.012.036	Washer D12 x 36
2	4	D0.12.5587G	M12 Nut
3	1	TE.010.060T	Screw TE M10 x 60
4	1	02.736.000	90 G. M10 x 1 Fitting
5	1	02.738.040	Greaser Extension M10 x 1 L=400
6	1	ID.010.001	Grease Nipple
7	1	02.737.000	Accessori
8	2	C0.500.03V	V-Belt
9	1	C0.690.J50	Poly V-Belt
10	2	RP.012.000	Washer D.12
11	4	TE.012.040T	Bolt TE M12 x 40

2.21 AXLE & WHEEL HUBS

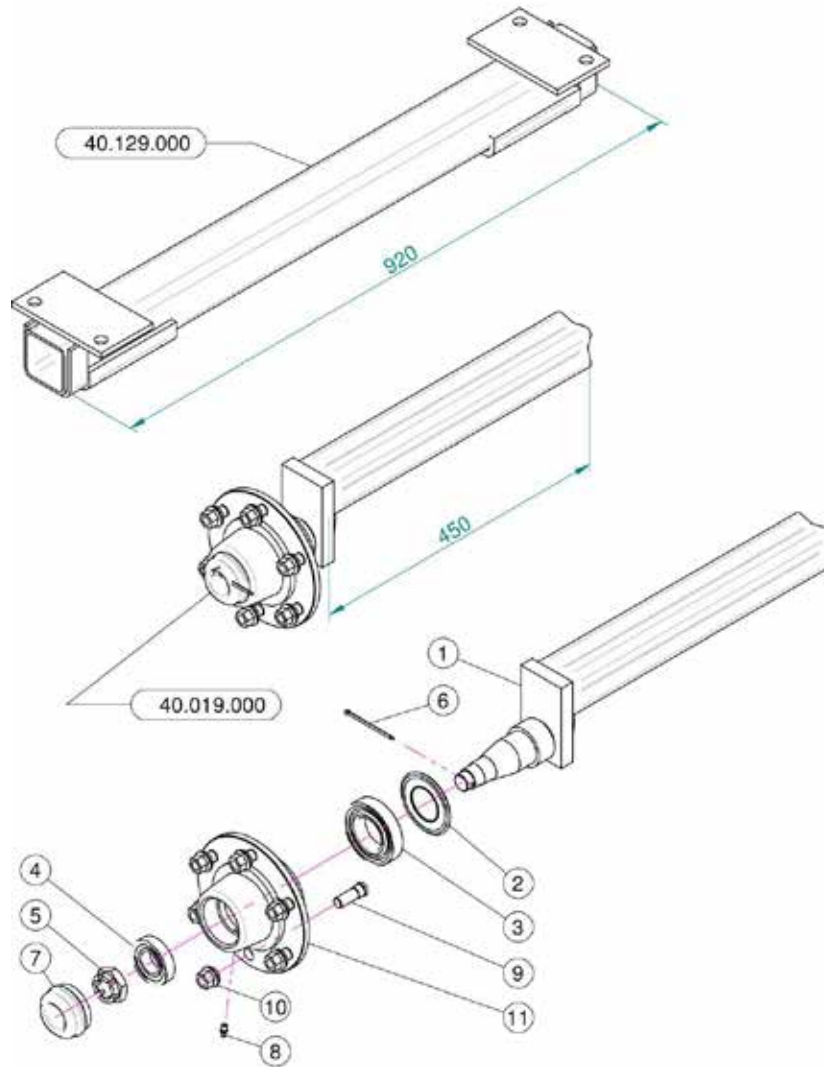

REF.	QTY.	PART NO.	DESCRIPTION
1	1	04.690.003	Axle Shaft
2	1	20.258.000	Oil Cover
3	1	K0.030.209	Bearing
4	1	K0.030.206	Bearing
5	1	DI.027.5594F	Six Castle Nut M27
6	1	CP.004.070I	Split Pin D.40 Lg. 70
7	1	04.062.001	Cover
8	1	ID.006.001	Greaser
9	6	05.911.001	Stud
10	6	05.911.000	Special Nut
11	1	05.903.001	Six Holes Flange

2.22 DRIVELINE ASSEMBLY - 7G7R091U2WR7R07

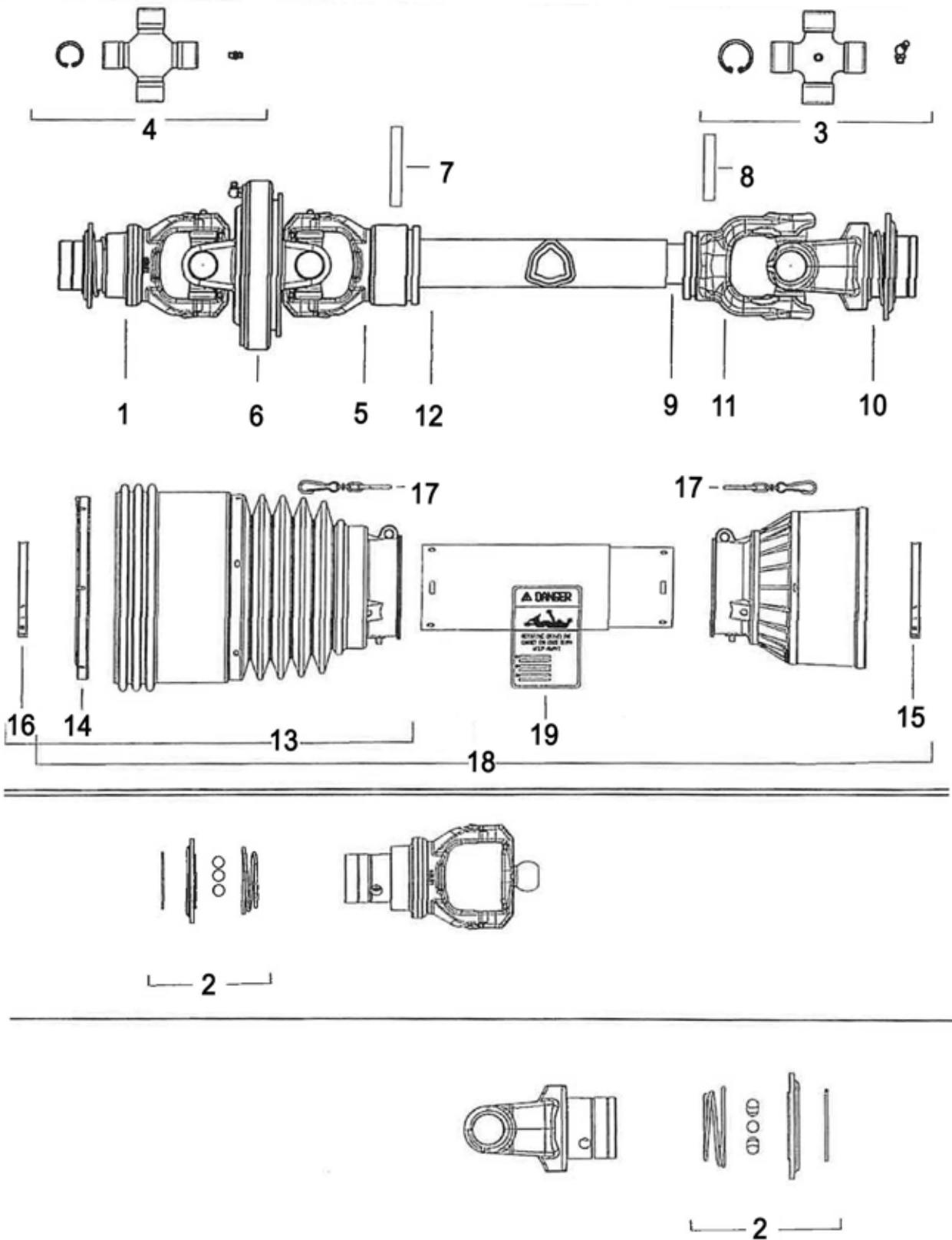

2.22 DRIVELINE ASSEMBLY - 7G7R091U2WR7R07

<u>REF. NO.</u>	<u>QTY.</u>	<u>PART NO.</u>	<u>DESCRIPTION</u>
1	1	5730G0384	CV Yoke 1-3/8" - Z=6 #G7
2	2	435000323R	Collar Kit #G7
3	1	4120H0012R30	Cross Kit
4	1	4120G0051R24	Cross Kit CV
5	1	2150G6893	Yoke, CV Outer Tube
6	1	5110G0061	CV Body #G7
7	1	341042000R10	Roll Pin
8	1	341043000R10	Roll Pin
9	1	225111200	Inner Drive Tube
10	1	5720H0355	Yoke #6 1-3/8" - Z=6
11	1	204066852	Yoke, Inner Tube
12	1	125171500	Tube, Outer CV
13	1	219051401	CV Shield Cone
14	1	2550G0024R02	CV Shield Bearing
15	1	255071001R02	Shield Bearing Inner Tube
16	1	255071002R02	Shield Bearing Outer Tube
17	2	AS101	Safety Chain
18	1	5CG7121FXWS	Complete Shield #G7
19	1	399CEE051	Safety Decal

3 LIMITED WARRANTY



GEARMORE, INC., warrants each new Gearmore product to be free from defects in material and workmanship for a period of twelve (12) months from date of purchase to the original purchaser. This warranty shall not apply to implements or parts that have been subject to misuse, negligence, accident, or that have been altered in any way.

Our obligation shall be limited to repairing or replacement of any part, provided that such part is returned within thirty (30) days from date of failure to Gearmore through the dealer from whom the purchase was made, transportation charges prepaid.

This warranty shall not be interpreted to render us liable for injury or damages of any kind or nature, direct, consequential or contingent, to person or property. This warranty does not extend to loss of crops, loss because of delay in harvesting or any other expenses, for any other reasons.

Gearmore in no way warrants engines, tires, or other trade accessories, since these items are warranted separately by these respective manufacturers.

Gearmore reserves the right to make improvements in design or changes in specification at any time, without incurring any obligations to owners or units previously sold.

Please be advised that all warranty work done by your dealer must be approved by Gearmore before work begins.

GEARMORE, INC.
13477 Benson Ave.
Chino, CA 91710

Always refer to and heed machine operating warning decals on machine.

*To validate the warranty on this product, please log-in to our website - www.gearmore.com.
You will find "warranty registration" listed at the top of our homepage.*