



# **VENTURI AIR SPRAYERS**

**Parts Manual For  
Model T45N1-800  
Trailer Mounted**

**July 2002**

# TABLE OF CONTENTS

Frame Assembly .....	1-2
Axle Assembly .....	3
Tank Assembly .....	4-5
Agitation Assembly .....	6-7
Fan Assembly .....	8
Fan Support & Belt Tensioner .....	9-13
Main Drive Pulley & Clutch Assembly .....	14-15
Fan Support .....	16
Main Pump Liquid Flow Path .....	17-19
In-Line Filter Assembly .....	20
Pump Tension Pulley Assembly .....	21-23
Manually Operated Valve .....	24
Manual Command Group 2-Way .....	25
Optional Control Box For Solenoid Valve .....	26
Optional Solenoid Control Valve .....	27-28
PTO Driveshaft .....	29
Limited Warranty .....	30

Date of Purchase:\_\_\_\_\_

Model Number:\_\_\_\_\_

Serial Number:\_\_\_\_\_

# FRAME ASSEMBLY

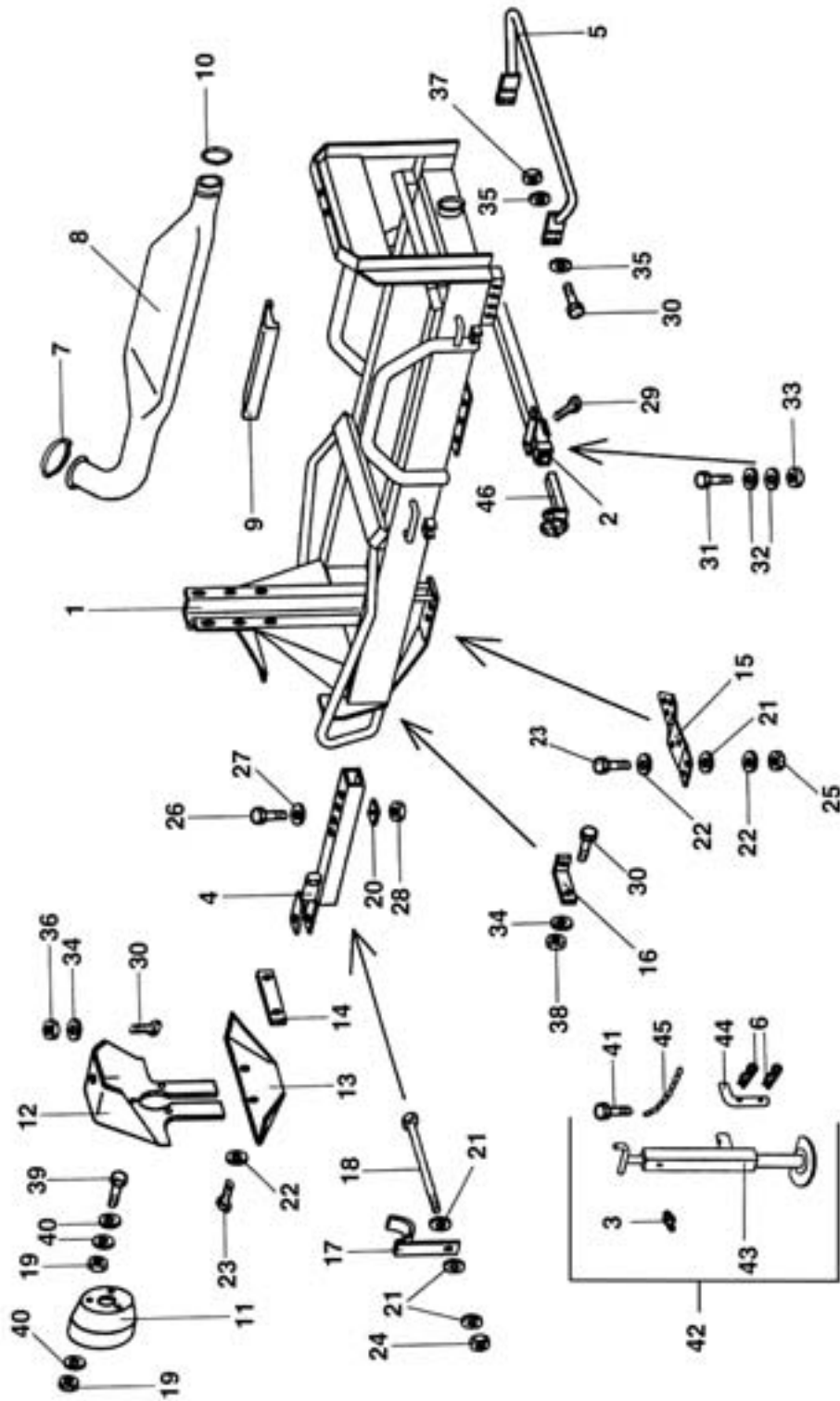

# FRAME ASSEMBLY

<u>REF#</u>	<u>QTY.</u>	<u>PART NO.</u>	<u>DESCRIPTION</u>
1	1	40.124.100	Main Frame
2	1	40.126.000	Axle Tube
3	1	ID.008.001	Grease Zerk M8 x 1
4	1	40.135.000C	Tongue
5	1	40.000.000	Rear Bumper
6	2	00.100.004	Hair Pin
7	2	05.616.000	Clamp D.190
8	1	40.141.100	Air Delivery Tube
9	2	20.484.000	Support Plate
10	1	40.147.000	Gasket
11	1	02.440.000	Cone, PTO
12	1	04.866.050	Cover, Fan
13	1	20.531.000	Cover, Lower Fan
14	1	20.532.000	Spacer, Threaded
15	2	20.530.000	Support Plate
16	2	20.529.000	Bracket
17	1	40.140.100	Support, PTO
18	1	TE.008.100	Bolt M8 x 100
19	3	DO.06.5588G	Nut M6
20	1	05.713.000	Spacer
21	7	RP.008.024	Washer D.8 x 24
22	10	RP.008.000	Washer D.8
23	6	TE.008.020T	Bolt M8 x 20
24	1	DA.008.OAG	Nut M8
25	4	DO.08.5588G	Nut M8
26	1	TE.018.120	Bolt M18 x 120
27	1	RP.018.000	Washer D.18
28	1	DA.018.OAG	Nut M18 x 2.5
29	4	TE.014.030T	Bolt M14 x 30
30	8	TE.010.030T	Bolt M10 x 30
31	4	TE.014.040T	Bolt M14 x 40
32	8	RP.014.000	Washer D.14
33	4	DO.14.5588G	Nut M14
34	3	RP.010.030	Washer D.10 x 30
35	8	RP.010.000	Washer D.10
36	1	DOT.10.5587	Nut M10
37	3	DO.10.5588G	Nut M10
38	2	DA.010.OAG	Nut M10 x 1.5
39	3	TE.006.025T	Bolt M6 x 25
40	9	RP.006.000	Washer D.6
41	1	TE.006.020T	Bolt M6 x 20
42	1	04.993.070C	Jackstand Assembly
43	1	04.993.070	Jackstand Only
44	1	20.505.000	Pin
45	1	02.278.040	Chain
46	2	40.020.100	Axle & Hub Assembly

# AXLE ASSEMBLY

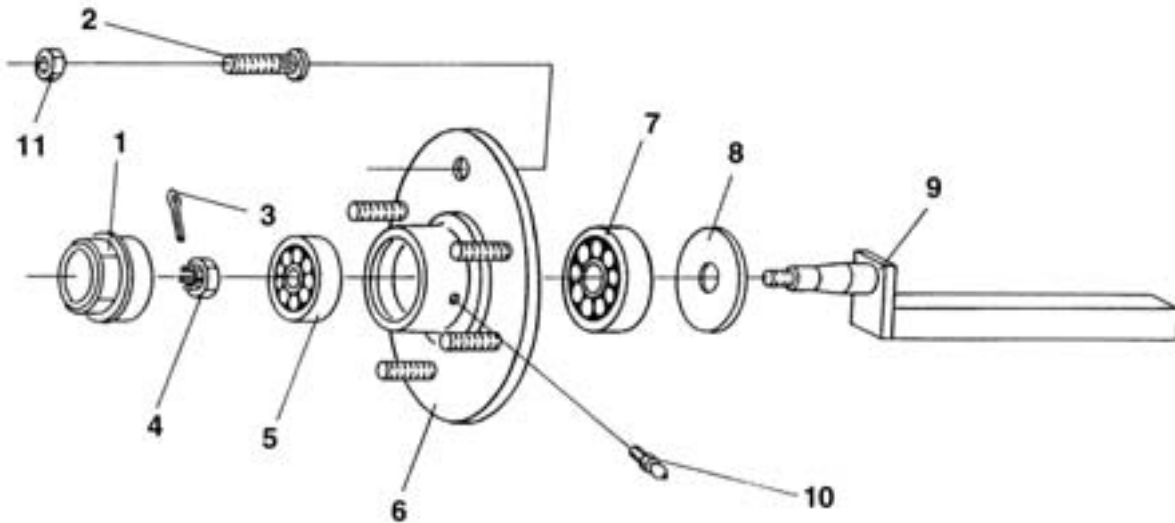

<u>REF#</u>	<u>QTY.</u>	<u>PART NO.</u>	<u>DESCRIPTION</u>
1	2	04.062.001	Dust Cap
2	12	05.911.001	Stud, Drive-In
3	2	(Obtain Locally)	
4	2	DI.027.5593F	Castellated Nut
5	2	30206	Bearing
6	2	40.047.001	Hub
7	2	30208	Bearing
8	2	20.257.000	Cover D.45 x 85
9	2	40.683.006	Axle
10	2	ID.006.001	Grease Nipple
11	12	05.911.000	Lug Nut

# TANK ASSEMBLY

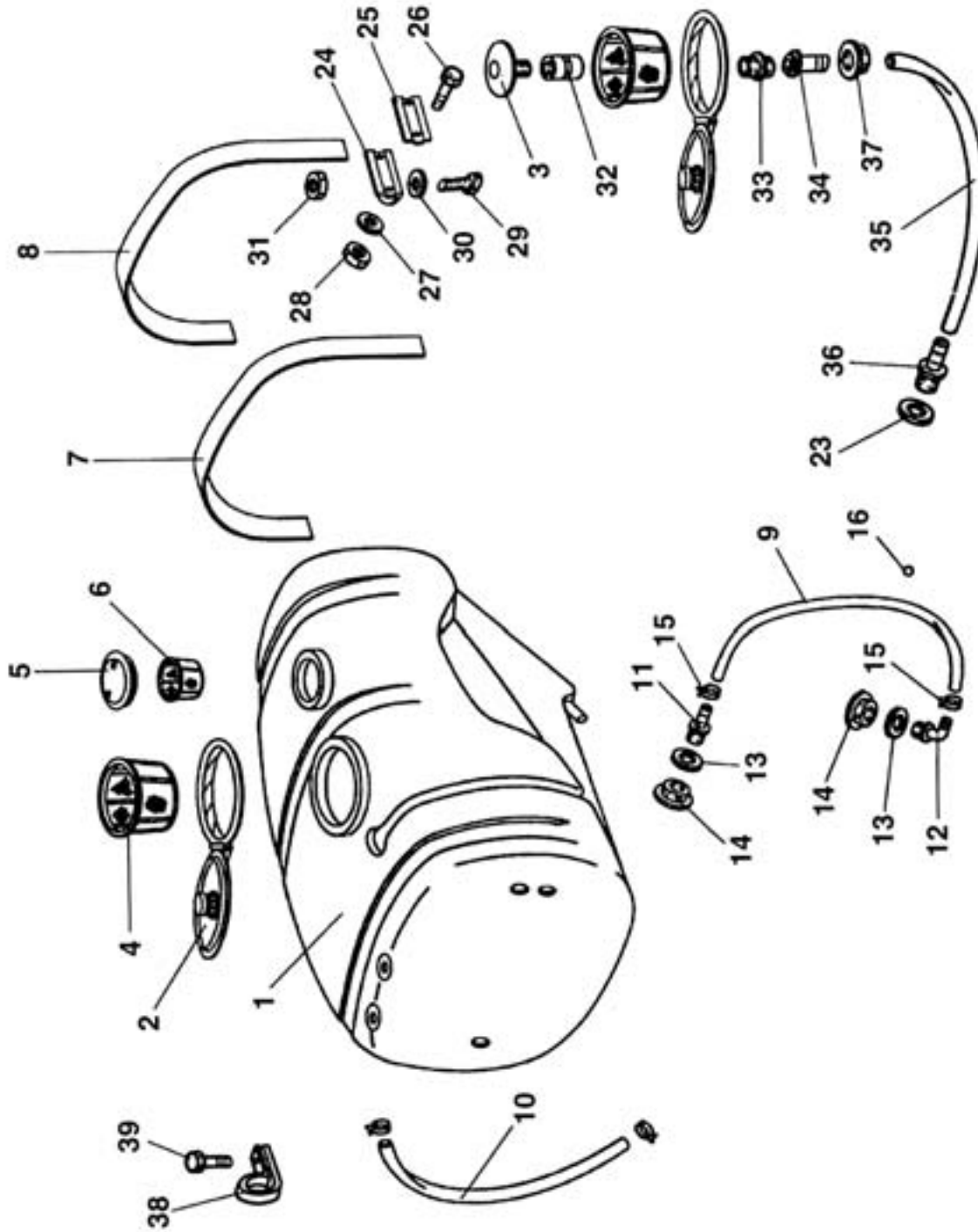

# TANK ASSEMBLY

<u>REF#</u>	<u>QTY.</u>	<u>PART NO.</u>	<u>DESCRIPTION</u>
1	1	40.117.100C	Poly Tank 200 Gallon
2	1	02.405.000	Lid Assembly
3	1	00.131.010	Shower Head
4	1	02.404.000	Strainer Basket 400 x 330
5	1	02.476.000	Small Lid
6	1	02.298.000	Strainer Basket D.204
7	1	02.481.275	Nylon Strap L=2750
8	1	02.481.250	Nylon Strap L=2500
9	1	02.378.150	Sight Gauge Hose D.12 x 16 L=1500
10	1	02.378.085	Sight Gauge Hose D.12 x 16 L=850
11	2	02.482.000	Threaded Nipple D.13 x 1/2"
12	2	02.457.000	Threaded Elbow D.13 x 1/2"
13	4	02.265.000	Gasket D.29 x 3
14	4	02.458.000	Plastic Nut 1/2"
15	4	10.164.000	Clamp D.15.9 x 16.8
16	2	02.478.000	Float Ball D.8.5
23	1	02.032.000	Gasket D.26 x 40
24	4	20.512.000	Clamp, Strap
25	4	20.513.000	Clamp, Strap
26	8	TE.006.025T	Bolt M6 x 25
27	8	RP.006.000	Washer D.6
28	8	DA.006.OAG	Nut M6
29	4	TE.010.080T	Bolt M10 x 80
30	4	RP.010.000	Washer D.10
31	4	DOT.10.5587	Nut M10
32	1	00.373.000	Adapter 1" Gas
33	1	00.055.034	Nipple 1" Gas
34	1	00.055.022	Nipple D.19
35	As Req'd	02.212.000	Hose D.19 Per Foot
36	1	00.418.000	Nipple D.19 x 3/4" Gas
37	1	00.055.24.2	Plastic Nut 1" Gas
38	2	FG.018.000	Hose Support
39	2	TE.008.016T	Bolt M8 x 16

# AIR AGITATION ASSEMBLY

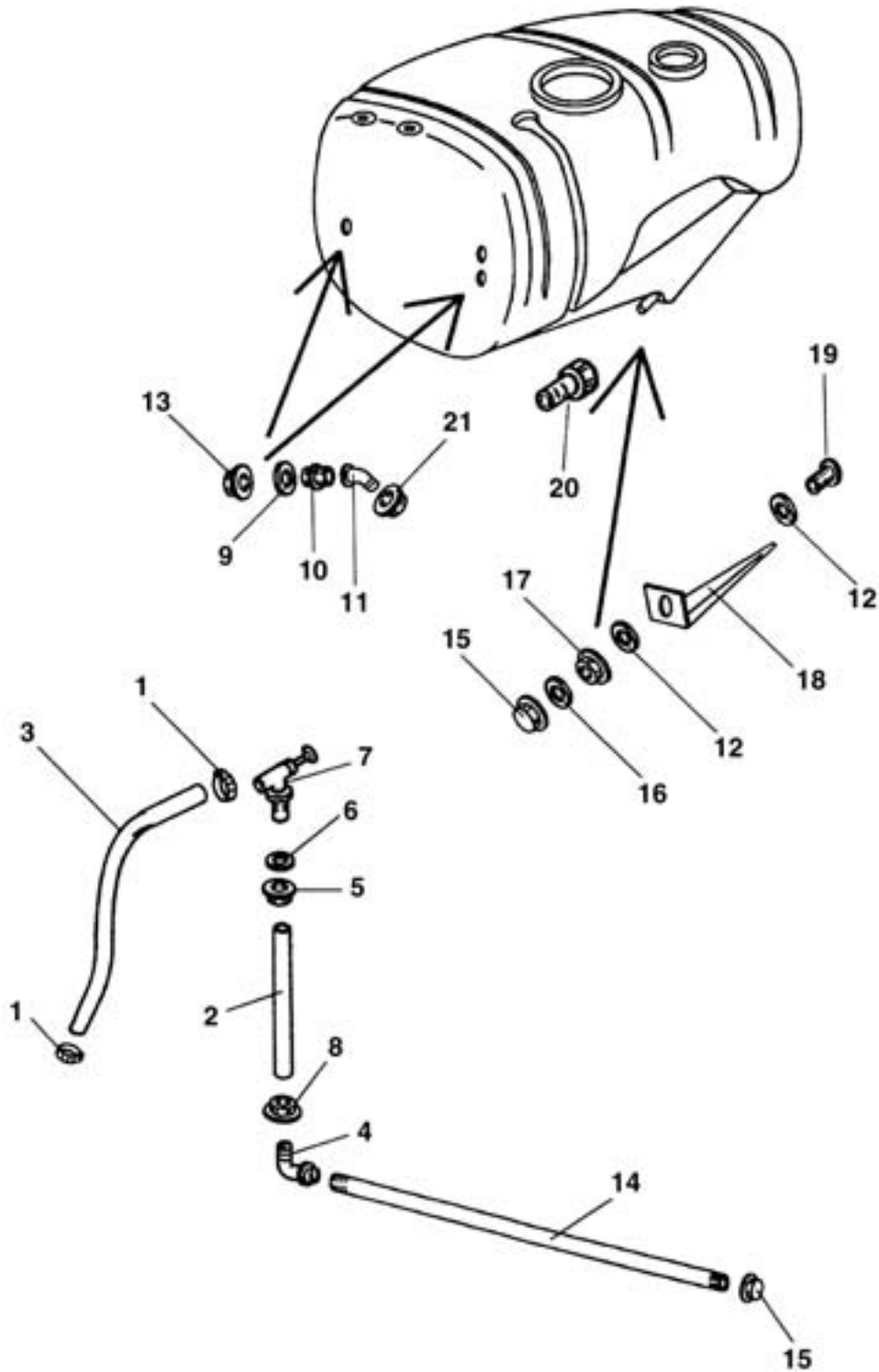



# AIR AGITATION ASSEMBLY

<u>REF#</u>	<u>QTY.</u>	<u>PART NO.</u>	<u>DESCRIPTION</u>
1	2	FO.014.024	Clamp D.14 x 24
2	As Req'd	02.212.000	Hose D.19 Per Foot
3	As Req'd	02.372.000	Hose D.19 Per Foot
4	2	00.055.037	Elbow D.25
5	1	00.541.000	Nut 3/4" Gas
6	1	02.032.000	Gasket D.26 x 40
7	1	02.135.000	Piston
8	3	00.055.24.2	Plastic Nut 1" Gas
9	2	02.033.000	Gasket D.42 x 55 x 3
10	2	00.345.000	Threaded Nipple 1-1/4
11	2	02.339.000	Elbow D.30
12	2	02.066.000	Gasket D.33 x 45
13	2	00.543.000	Cap 1-1/4" Gas
14	1	40.035.001	Tube 1" L=1200
15	2	TF.001.000	Cap 1"
16	1	02.265.000	Gasket D.29 x 3
17	1	00.542.000	Plastic Nut 1" Gas
18	1	20.498.000	Support Bracket
19	1	00.587.000	Nipple 1" Gas
20	1	1400032	Threaded Nipple 1-1/4"
21	2	00.493.000	Plastic Nut 1-1/4"

# FAN ASSEMBLY

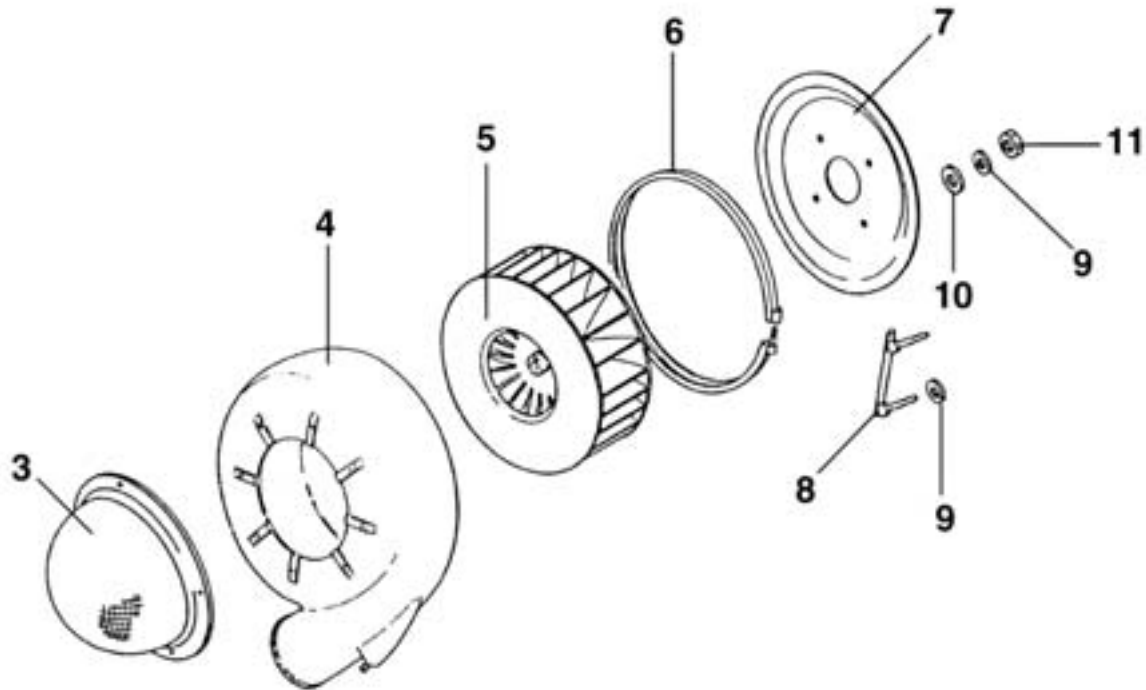

<u>REF#</u>	<u>QTY.</u>	<u>PART NO.</u>	<u>DESCRIPTION</u>
1	4	TE.006.010T	Bolt M6 x 10 (not shown)
2	4	RP.006.024	Washer D.6 x 24 (not shown)
3	1	05.654.100	Cover, Wire Mesh
4	1	04.854.000	Housing
5	1	04.720.000	Fan
6	1	04.874.000	Clamp D.485
7	1	04.853.000	Cover
8	2	20.088.000	Bolt Assembly
9	8	RP.010.030	Washer D.10 x 30
10	4	RP.010.040	Washer D.10 x 40
11	4	DO.10.5588G	Nut M10

# FAN SUPPORT & BELT TENSIONER

For S/N 90287 - 000300

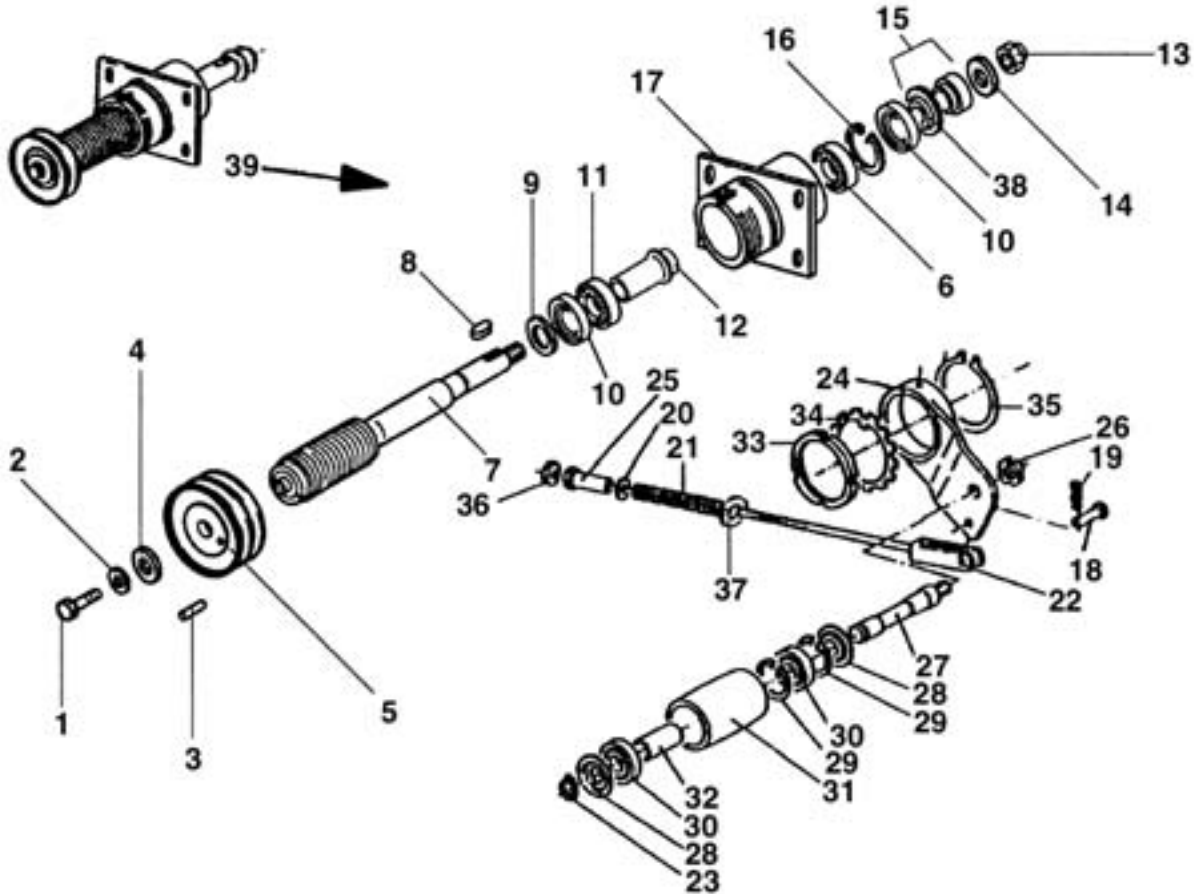

<u>REF#</u>	<u>QTY.</u>	<u>PART NO.</u>	<u>DESCRIPTION</u>
1	1	TE.010.025FT	Bolt 10 x 25
2	1	RP.010.028	Washer D.10 x 28
3	1	SE.006.020	Spring Pin 6 x 20
4	1	RP.010.040	Washer D.10 x 40
5	1	02.723.003	Pulley
6	1	21305	Bearing
7	1	04.721.054	Shaft, Fan Support
8	1	L.08.07.35	Key 8 x 7 x 35
9	1	04.862.000	Cover
10	2	AL.STO.35.62	Seal 35 x 62
11	1	22206	Bearing
12	1	04.864.010	Spacer

# FAN SUPPORT & BELT TENSIONER

<u>REF#</u>	<u>QTY.</u>	<u>PART NO.</u>	<u>DESCRIPTION</u>
13	1	DA.022.OBF	Nut
14	1	RP.022.000	Washer D.22
15	1	04.863.000	Bushing w/Cover
16	1	IO.062.000	Circlip I62
17	1	04.865.010	Housing

## BELT STRETCHER

18	1	04.593.000	Pin
19	1	00.100.002	Clip
20	1	RP.019.000	Washer D.19
21	1	04.578.000	Spring
22	1	05.653.000	Rod, Adjustment
23	1	EO.025.000	Circlip E25
24	1	04.095.000	Idler Support
25	1	04.583.000	Screw Threaded Spacer
26	1	KM.005.000	Nut
27	1	04.835.000	Pivot Pin
28	2	04.585.000	Cover
29	2	IO.052.000	Circlip I52
30	2	6205-2RS	Bearing
31	1	04.083.000	Roller
32	1	04.084.000	Spacer
33	1	04.099.000	Nut
34	1	MB.016.000	Lock Ring
35	1	EO.080.000	Circlip E80
36	1	DO.12.5588G	Nut
37	1	20.260.000	Special Washer D.12
38	1	04.863.002	Cover

## COMPLETE FAN SUPPORT

39	1	04.865.19C	Fan Support w/Shaft and Pulley
----	---	------------	--------------------------------

# FAN SUPPORT & BELT TENSIONER

For S/N 020135 ---

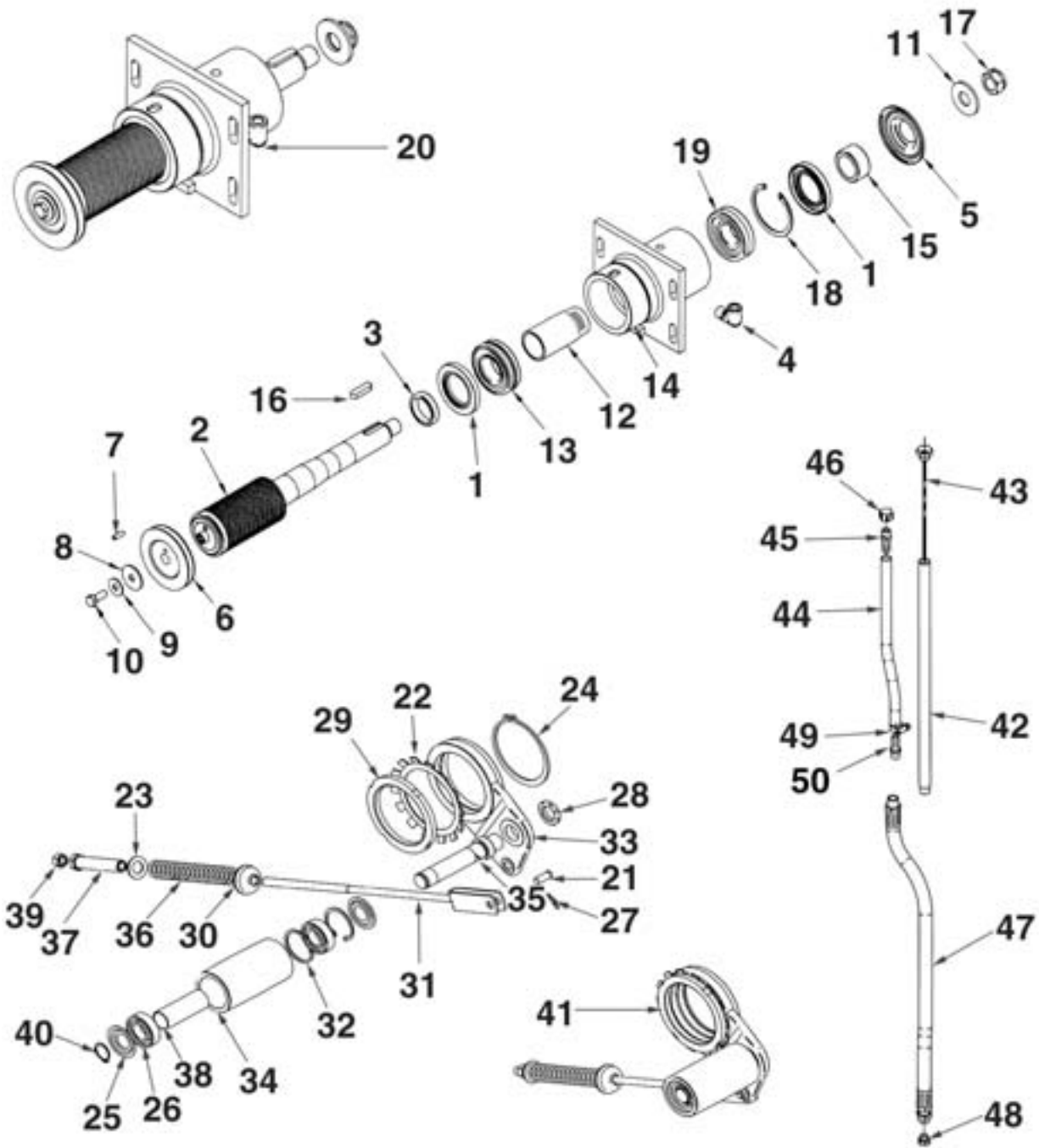

# FAN SUPPORT & BELT TENSIONER

For S/N 020135 ---

<u>REF#</u>	<u>QTY.</u>	<u>PART NO.</u>	<u>DESCRIPTION</u>
1	2	50X80X10	Oil Seal
2	1	40.271.054	Shaft D.54
3	1	40.264.000	Bushing
4	1	20.789.000	90° Elbow
5	1	40.267.000	Cover
6	1	02.723.003	Pulley D.995
7	1	SE.006.020	Roll Pin
8	1	RP.010.040	Washer D.10 x 40
9	1	RP.010.028	Washer D.10 x 28
10	1	TE.010.025FT	Bolt M10 x 25
11	1	RP.022.000	Washer D.22
12	1	40.262.000	Spacer
13	1	22206	Bearing
14	1	40.260.000	Housing
15	1	40.263.000	Spacer
16	1	L.08.07.35	Key 8 x 7 x 35
17	1	DA.022.0BF	Nut M22 x 1.5
18	1	I0.062.000	Circlip I62
19	1	21305	Bearing
20	1	40.284.000	Support Assembly

## BELT TENSIONER

21	1	04.593.000	Pin
22	1	MB.016.000	Washer
23	1	RP.019.000	Washer D.19
24	1	E0.080.000	Circlip E80
25	2	04.585.000	Cover, Dust
26	2	6205-2RS	Bearing
27	1	00.100.002	Hair Pin
28	1	KM.005.000	Nut M5
29	1	04.099.000	Nut
30	1	20.260.000	Cup Washer
31	1	05.653.000	Rod, Adjustment
32	2	I0.052.000	Circlip I52
33	1	04.095.000	Support, Idler
34	1	04.083.000	Roller
35	1	04.835.000	Pin
36	1	04.578.000	Spring
37	1	04.583.000	Special Screw
38	1	04.084.000	Spacer
39	1	D0.12.5588G	Nut m12
40	1	E0.025.000	Circlip E25
41	1	04.850.000	Belt Tension Assembly

# FAN SUPPORT & BELT TENSIONER

For S/N 020135 ---

## OIL TUBE

<u>REF#</u>	<u>QTY.</u>	<u>PART NO.</u>	<u>DESCRIPTION</u>
42	1	40.272.000	Pipe L=450
43	1	40.269.000	Dipstick
44	1	02.213.050	Breather D.10 L=500
45	1	00.414.100	Hose D.11
46	1	02.013.000	Plug
47	1	20.790.000	Drain Pipe L=585
48	1	40.266.000	Drain Plug M12 x 1.5
49	1	F0.008.016I	Clamp
50	1	20.792.000	Hose D.11

# MAIN DRIVE PULLEY ASSEMBLY & CLUTCH

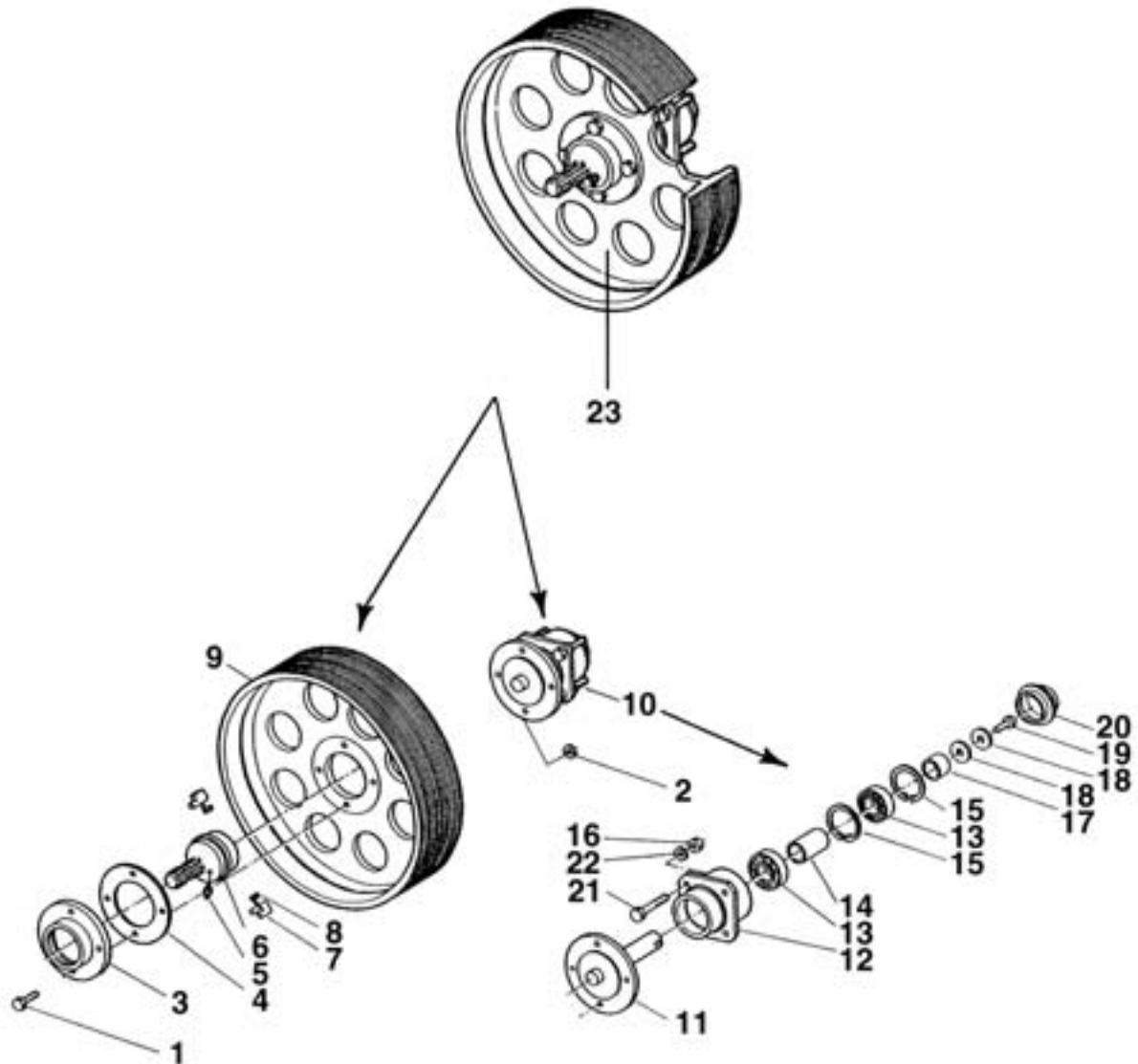



# MAIN DRIVE PULLEY ASSEMBLY & CLUTCH

<u>REF#</u>	<u>QTY.</u>	<u>PART NO.</u>	<u>DESCRIPTION</u>
1	4	TE.012.040F	Bolt TE M12 x 40
2	4	DO.10.5588G	Nut
3	1	04.066.000	Housing
4	1	04.719.000	Gasket
5	1	ID.010.001	Grease Nipple M10
6	1	03.701.000	Ratchet Clutch
7	2	02.502.002	Key
8	2	02.502.001	Spring
9	1	00.450.J32	Pulley
10	1	04.094.01C	Support Assembly
11	1	04.085.000	Shaft
12	1	04.094.000	Housing
13	2	6206-2RS	Bearing
14	1	04.060.000	Spacer Bar
15	2	IO.062.000	Internal Circlip D.62
16	4	DO.10.5588G	Nut
17	1	04.590.000	Spacer
18	2	RP.012.036	Washer D.12 x 36
19	1	TE.012.025FT	Bolt M12 x 25
20	1	04.062.001	Hub Cover
21	4	TE.010.080	Bolt M10 x 80
22	4	RP.010.000	Washer D.10
23	1	04.094.03C	Clutch & Pulley Support Assembly

# FAN SUPPORT

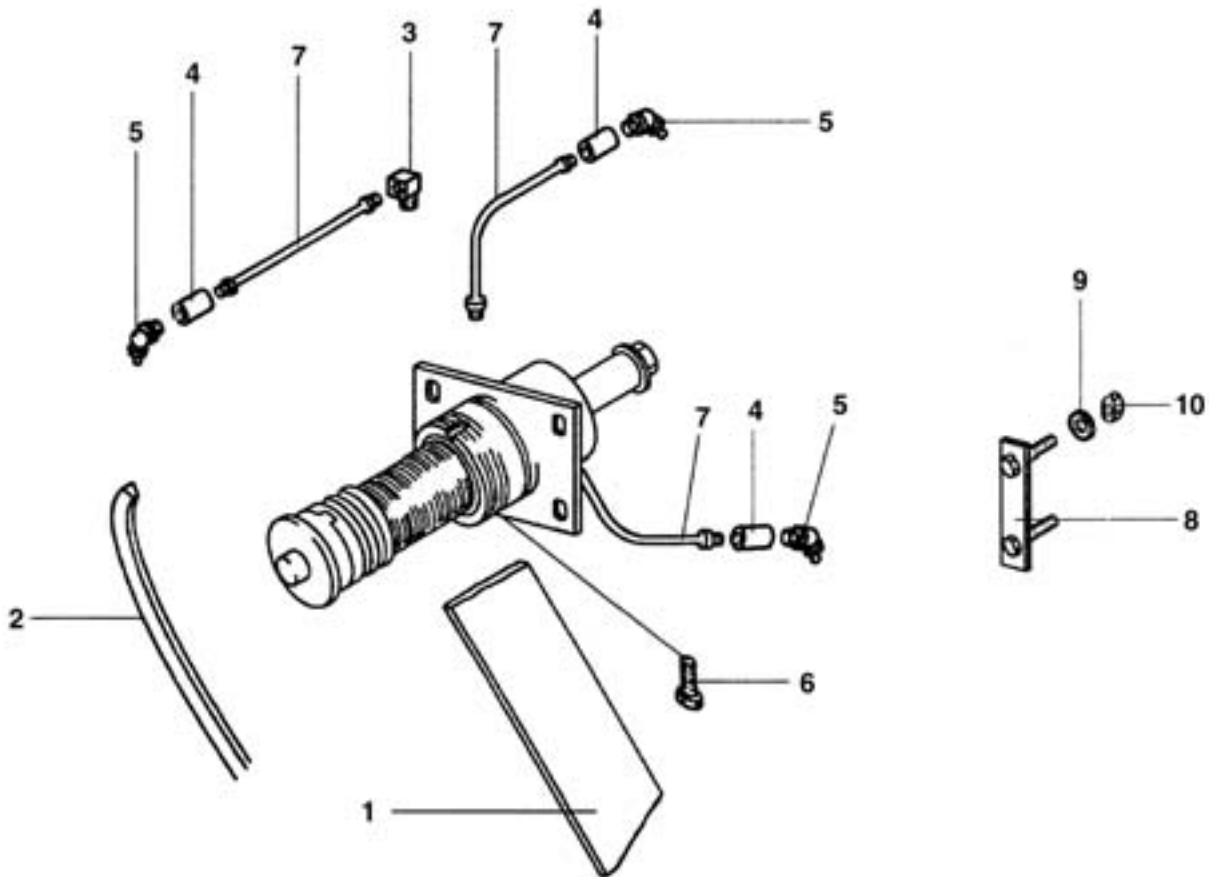

<u>REF#</u>	<u>QTY.</u>	<u>PART NO.</u>	<u>DESCRIPTION</u>
1	1	C0.650.J32	Drive Belt
2	1	C0.500.03V	V-Belt 3V500
3	1	02.736.000	90° Fitting Belt Idler
4	3	02.737.000	Nipple s/n 90287 - 000300
4	1	02.737.000	Nipple s/n 020135 - -----
5	3	IS.010.001	Grease Zerk s/n 90287 - 000300
5	1	IS.010.001	Grease Zerk s/n 020135 - -----
6	4	TE.010.060T	Bolt M10 x 60
7	3	02.738.040	Extension M10 x 1 x 400 s/n 90287 - 000300
7	1	02.738.040	Extension M10 x 1 x 400 s/n 020135 - -----
8	2	02.945.000	Bolt Clamp
9	4	RP.012.036	Washer D.12 x 36
10	4	DO.12.5588G	Nut M12

# MAIN PUMP LIQUID FLOW PATH

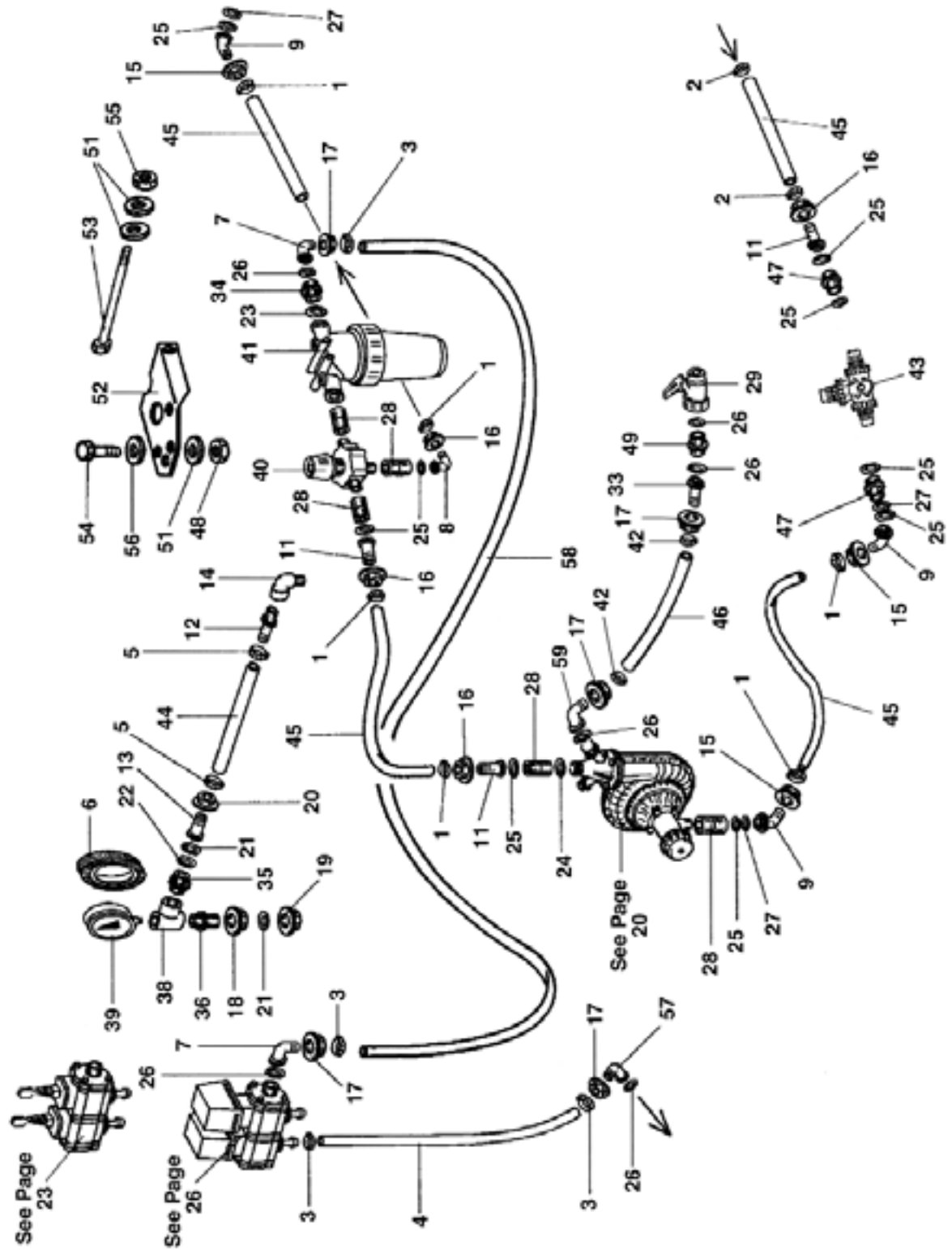

# MAIN PUMP LIQUID FLOW PATH

<u>REF#</u>	<u>QTY.</u>	<u>PART NO.</u>	<u>DESCRIPTION</u>
1	6	FO.025.045	Clamp D.25/45
2	2	FO.032.052	Clamp D.32/52
3	2	FO.024.036	Clamp D.24 x 36
4	As Req'd	02.211.000	Hose D.16 Per Foot
5	2	FO.014.024	Clamp D.14 x 24
6	1	02.470.000	Cover
7	2	00.055.037	Hosetail 90° D.25
8	1	00.058.004	Hosetail 90° D.30
9	3	02.339.000	Hosetail 45° D.30
10	1	00.437.000	Hosebarb D.40
11	2	00.055.028	Hosebarb D.30
12	1	00.414.000	Hosebarb D.11 x 1/4" M
13	1	02.122.000	Hosebarb D.13
14	1	20.172.000	Elbow M/F 1/4"
15	3	00.493.000	Plastic Nut 1-1/4" Gas
16	3	00.058.006	Plastic Nut 1-1/4"
17	6	00.055.242	Plastic Nut 1" Gas
18	1	02.458.000	Plastic Nut 1/2"
19	1	TF.012.000	Cap 1/2" Gas
20	1	00.055.045	Plastic Nut 3/4" Gas
21	2	OR.000.117	O-Ring D.13.1 x 2.62
22	3	OR.000.121	O-Ring D15.88 x 2.62
23	1	OR.000.511	O-Ring D.42 x 3.5
24	2	OR.000.508	O-Ring D.30 x 3
25	8	OR.003.112	O-Ring D.28.24 x 2.62
26	7	OR.000.132	O-Ring D.23.81 x 2.62
27	3	OR.003.106	O-Ring D.26.64 x 2.62
28	5	02.374.000	Reducer 1" F/1-1/4" M
29	1	02.395.00	Ball Valve F-F
30	1	02.120.000	Cap (not shown)
31	1	04.111.022	Chain L=220 (not shown)
32	1	02.130.000	Gasket D.24 x 46 x 3 (not shown)
33	1	00.055.022	Nipple
34	1	00.045.012	Nipple 1-1/4"
35	1	00.055.044	Reducer 1/2" - 3/4" Gas
36	1	02.493.000	Nipple 1/2" - 1/2"
37	1	00.494.000	Plastic Nut 1-1/2" Gas
38	1	00.350.000	Tee, Liquid 1/2"
39	1	02.445.000	Gauge
40	1	02.447.000	Regulator Valve

# MAIN PUMP LIQUID FLOW PATH

<u>REF#</u>	<u>QTY.</u>	<u>PART NO.</u>	<u>DESCRIPTION</u>
41	1	02.450.000	Filter Assembly
42	2	10.287.000	Clamp
43	1	24.058.000	Ball Valve
44	As Req'd	02.213.000	Hose D.10 Per Foot
45	As Req'd	02.215.000	Hose D.30 Per Foot
46	As Req'd	02.212.000	Hose D.19 Per Foot
47	2	240045	Reducer 1" - 1 1/4"
48	2	DO.08.5588G	Nut M8
49	1	240034	Reducer 3/4" - 1"
50	5	TE.008.016T	Bolt M8 x 16
51	4	RP.008.000	Washer D.8
52	1	20.519.000	Support Bracket
53	1	TE.008.120	Bolt M8 x 120
54	2	TE.008.025T	Bolt M8 x 25
55	1	DA.008.OAG	Nut M8
56	2	RP.008.024	Washer D.8 x 24
57	2	00.055.046	Hosetail 90° D.17
58	As Req'd	02.219.000	Hose D.25 Per Foot
59	1	00.055.038	Elbow

# INLINE FILTER ASSEMBLY 02.450.010

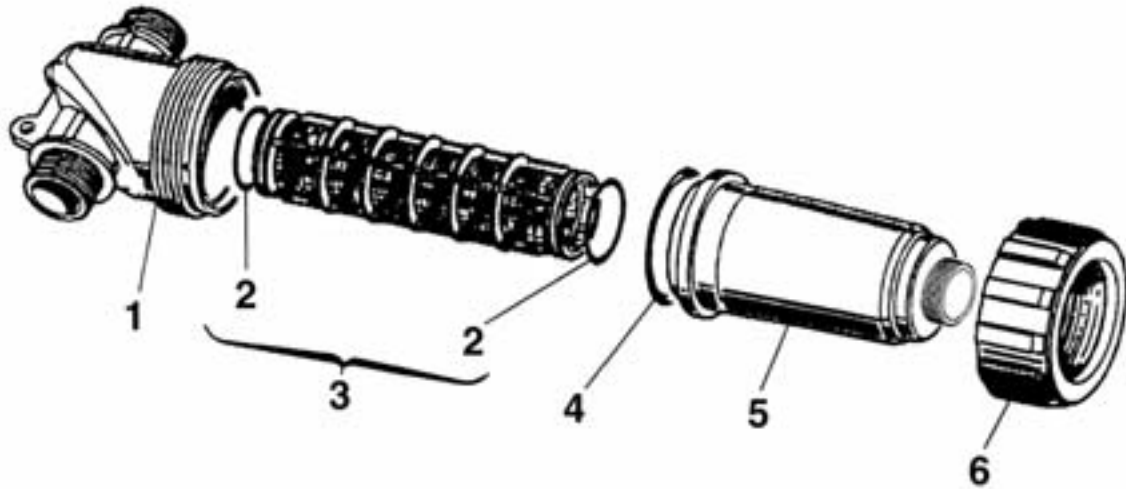

<u>REF#</u>	<u>QTY.</u>	<u>PART NO.</u>	<u>DESCRIPTION</u>
1	1	02.450.001	Body
2	2	OR3969353	O-Ring D.39.69 x 3.53
3	1	326003.030	Cartridge 50 Mesh (Blue)
3	Optional	326002.030	Cartridge 32 Mesh (White)
4	1	OR7463533	O-Ring D.74.63 x 5.33
5	1	02.450.011	Bowl
6	1	02.450.003	Back Nut
7	1	02.030.000	Gasket, Drain Cap (not shown)
8	1	02.182.000	Drain Cap (not shown)

# PUMP & TENSION PULLEY ASSEMBLY

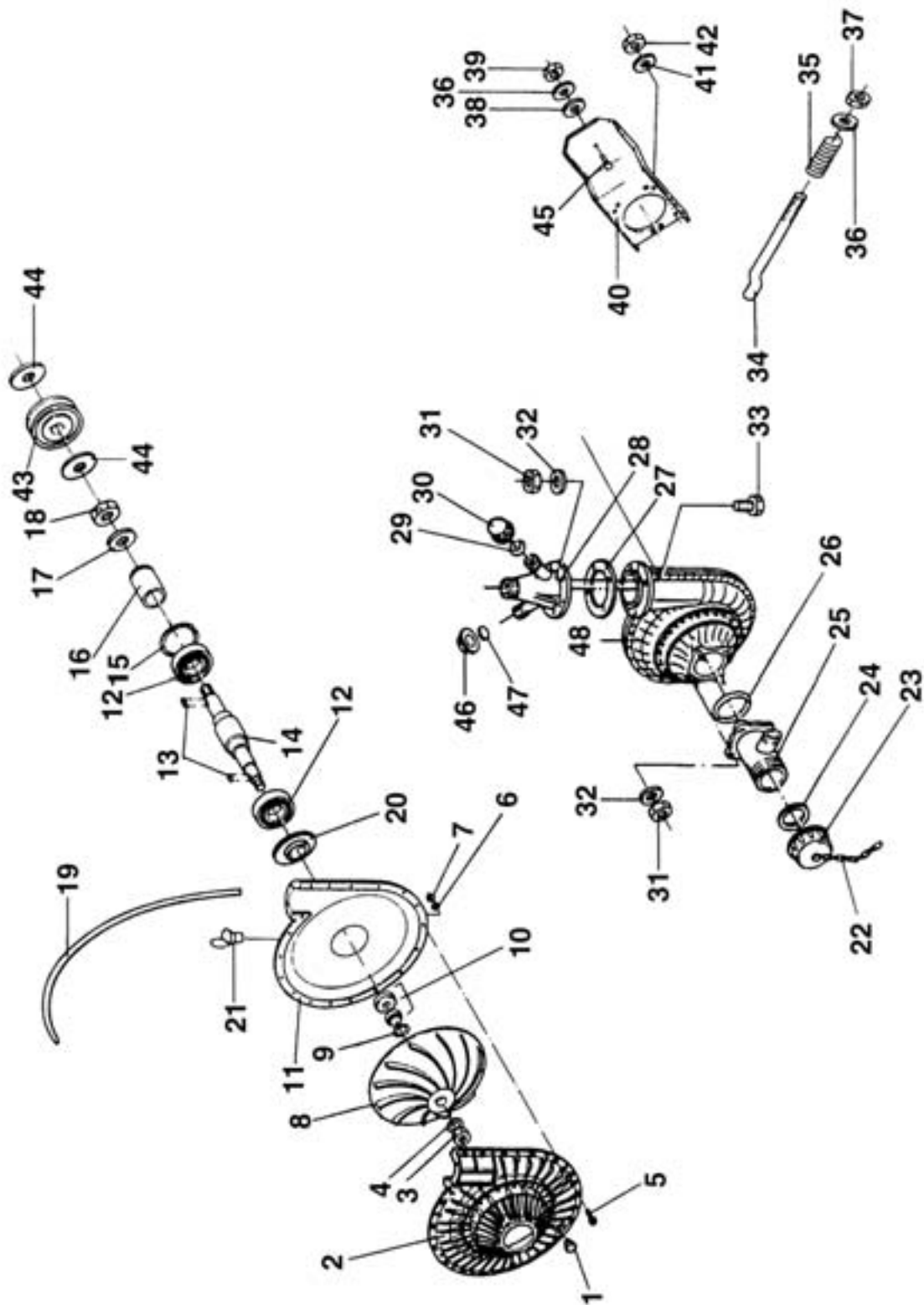

# PUMP & TENSION PULLEY ASSEMBLY

<u>REF#</u>	<u>QTY.</u>	<u>PART NO.</u>	<u>DESCRIPTION</u>
1	2	TM.010.015	Plug 10 x 1.5
2	1	02.152.010	Housing, Front Half
3	1	DOT.10.5587	Brass Nut M10
4	1	RP.010.00I	Washer D.10 INCX
5	17	TCC.05.25	Screw M5 x 25
6	17	RP.005.000	Washer D.5
7	17	DOT.05.5587	Brass Nut M5
8	1	02.153.000	Impeller
9	1	02.114.000	Washer
10	1	00.085.024CS	Pump Seal Kit
11	1	02.151.010	Housing Back Half
12	2	6303-2RS	Bearing
13	2	L.05.05.10	Key 5 x 5 x 10
14	1	02.155.010	Shaft
15	1	IO.047.000	Circlip I.47
16	1	02.722.000	Bushing
17	1	RP.010.000	Washer D.10
18	1	DO.10.5588G	Nut M10
19	1	OR.C02.070	O-Ring CORD D.2 L=700
20	1	20.406.000	Cover
21	1	02.473.000	Oil Feeder M8
22	1	04.111.022	Chain L=220
23	1	02.120.000	Cap, Drain
24	1	02.130.000	Gasket
25	1	02.116.000	Two Way Tap
26	1	OR.003.181	O-Ring
27	1	02.179.000	Gasket
28	1	02.113.000	Three Way Tap
29	1	02.265.000	Gasket D.29 x 3
30	1	TF.001.000	Cap
31	8	DOT.06.5587	Brass Nut M6
32	8	RP.006.000	Washer D.6
33	4	TE.006.025T	Bolt M6 x 25
34	1	20.447.000	Rod, M12 Belt Stretcher
35	1	02.964.000	Spring



# **PUMP & TENSION PULLEY ASSEMBLY**

<b><u>REF#</u></b>	<b><u>QTY.</u></b>	<b><u>PART NO.</u></b>	<b><u>DESCRIPTION</u></b>
36	2	RP.012.000	Washer D.12
37	1	DOT.12.5587	Brass Nut M12
38	1	MT.012.000	Belleville Washer D.12
39	1	DA.012.0AG	Nut M12 x 1.75
40	1	02.978.000SX	Bracket
41	3	RP.008.000	Washer D.8
42	3	DO.08.5588G	Nut M8
43	1	02.723.002	Pulley D.82 x 1 3V
44	2	02.723.001	Washer, 3mm Pulley
45	1	TE.012.035T	Bolt M12 x 35
46	1	TF.012.000	Cap
47	1	OR.000.117	O-Ring D.13.1 x 3.6
48	1	02.157.050	Pump Assembly

# MANUALLY OPERATED VALVE

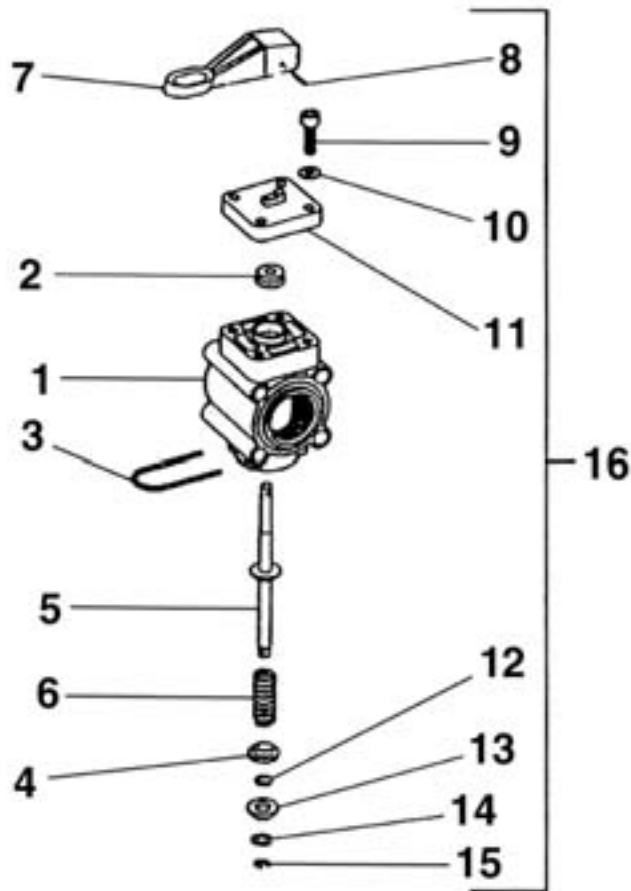

<u>REF#</u>	<u>QTY.</u>	<u>PART NO.</u>	<u>DESCRIPTION</u>
1	1	02.390.007	Body
2	4	02.390.008	Gasket
3	1	02.390.005	Clip
4	2	02.390.009	Cap
5	2	02.390.020	Pin
6	1	02.390.011	Spring
7	1	20.108.002	Lever For Manual Switch
8	1	SE.003.020	Spring Pin D.3 L=20
9	4	TCE.005.020	Cap Screw M5 L=20
10	4	RP.005.000	Washer D.5
11	1	02.390.021	Flange
12	1	02.390.016	O-Ring
13	1	02.390.015	Washer
14	1	02.390.014	Washer
15	1	02.390.013	Stop Ring
16	2	20.108.000	Valve, Manual Control

# MANUAL COMMAND GROUP 2-WAY

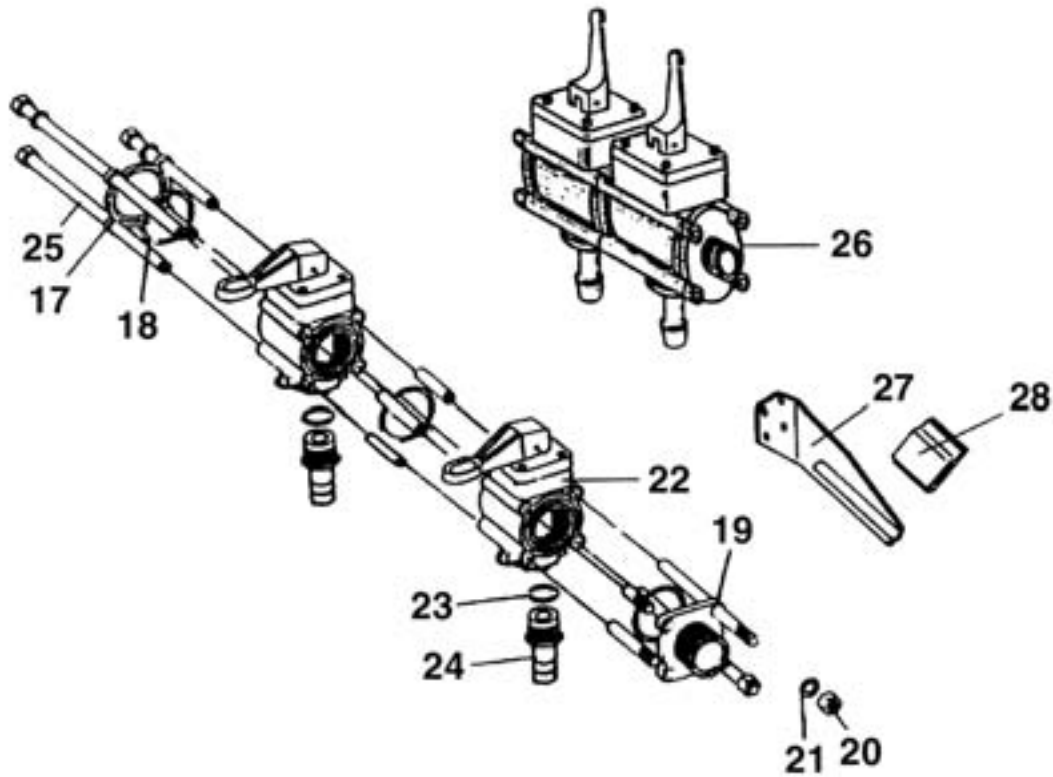

<u>REF#</u>	<u>QTY.</u>	<u>PART NO.</u>	<u>DESCRIPTION</u>
17	1	02.390.017	Seal Cap
18	3	OR.003.156	O-Ring
19	1	02.390.018	Connector
20	4	DO.08.5588G	Nut M8
21	8	RP.008.000	Washer D.8
22	2	20.108.000	Manually Operated Valve
23	2	OR.000.130	O-Ring
24	2	02.406.000	Nipple D.16
25	4	TCE.008.150	Bolt M8 x 150
26	4	20.108.01C	Manual Command Group Assembly
27	1	20.112.000	Bracket, Support
28	1	20.107.000	Pocket

# OPTIONAL CONTROL BOX FOR SOLENOID VALVE

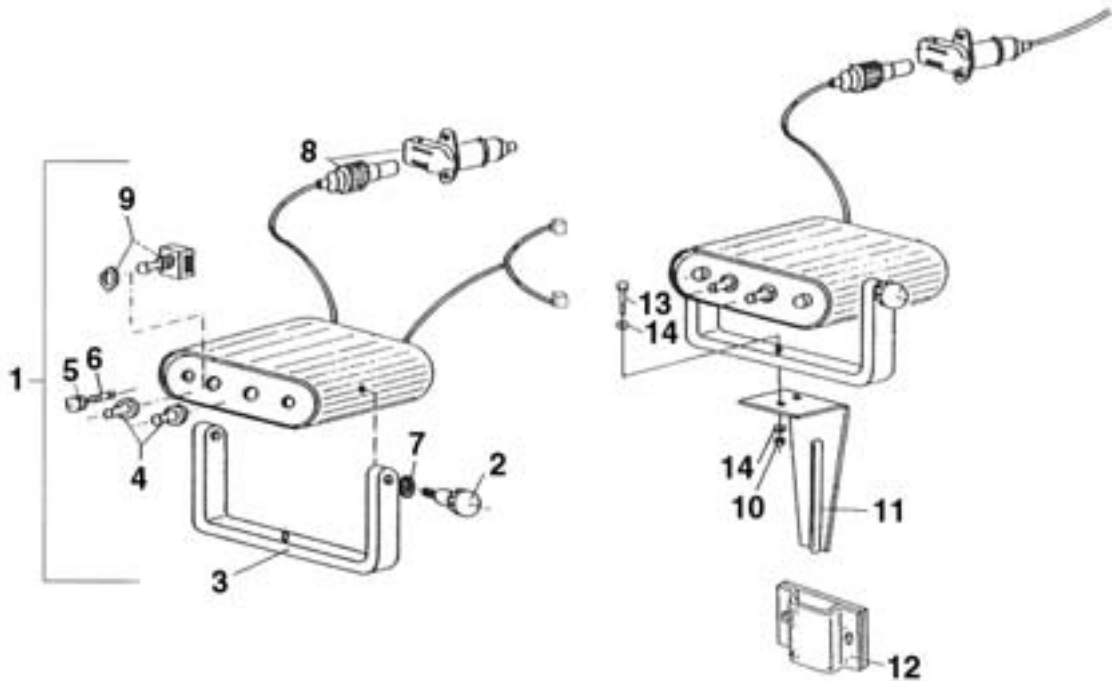

<u>REF#</u>	<u>QTY.</u>	<u>PART NO.</u>	<u>DESCRIPTION</u>
1	1	02.391.07C	Control Box Assembly L/Ref. 8
2	2	02.391.007	Knob, Bolt
3	1	02.391.006	Mounting Bracket for Box
4	2	02.391.001	Switch Cap
5	2	02.391.003	Panel Fuse Holder
6	2	02.391.004	Fuse 1.25 AMP
7	2	RD.006.000	Washer
8	1	02.391.005	Plug & Socket Kit
9	2	02.391.002	Double Pole Switch

## KIT FOR CONTROL SOLENOID VALVE

10	1	DA.008.0AG	Nut
11	1	20.111.000	Mounting Bracket Electric Control
12	1	20.107.000	Support Control Assembly
13	1	TE.008.025T	Bolt
14	2	RP.008.024	Washer D.8 x 24

# OPTIONAL SOLENOID CONTROL

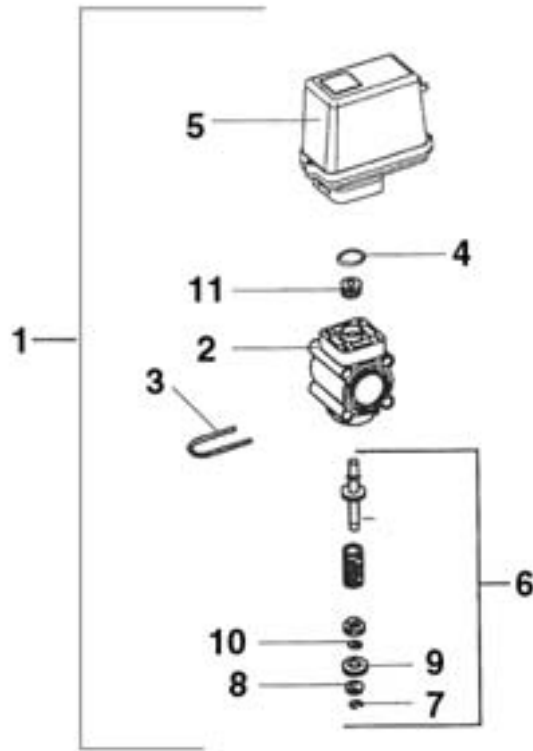

# OPTIONAL SOLENOID COMMAND GROUP

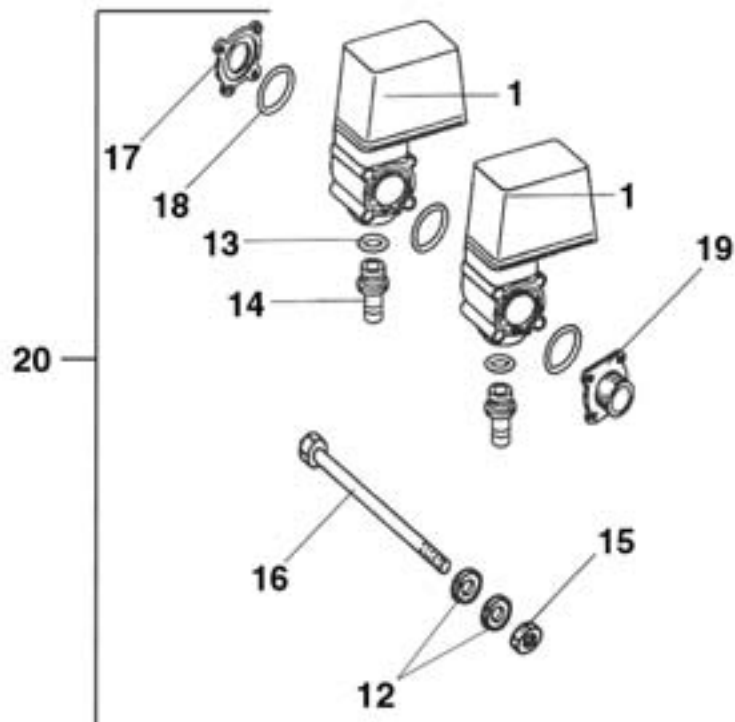

## OPTIONAL SOLENOID CONTROL

<u>REF#</u>	<u>QTY.</u>	<u>PART NO.</u>	<u>DESCRIPTION</u>
1	1	02.390.029	Solenoid Valve
2	1	02.390.007	Body
3	1	02.390.005	Clip
4	1	OR.002.075	O-Ring D.18.77 x 1.78
5	1	02.390.028	Motor
6	1	02.390.027	Stem Assembly
7	1	02.390.013	Lock Clip
8	1	02.390.014	Washer
9	1	02.390.015	Washer
10	1	02.390.026	O-Ring
11	1	02.390.008	Gasket

## OPTIONAL SOLENOID COMMAND GROUP

<u>REF#</u>	<u>QTY.</u>	<u>PART NO.</u>	<u>DESCRIPTION</u>
12	8	RP.008.000	Washer D.8
13	2	OR.000.130	O-Ring D.22.22 x 2.62
14	2	02.406.000	Hose Barb D.16
15	4	DO.08.5588G	Nut M8
16	4	TCE.008.150	Bolt M8 x 150
17	1	02.390.017	Flange
18	3	OR.003.156	O-Ring D.39 x 2.62
19	1	02.390.018	Connector
20	1	02.390.10C	Solenoid Command Group Assembly

# DRIVELINE 7654086S1T077

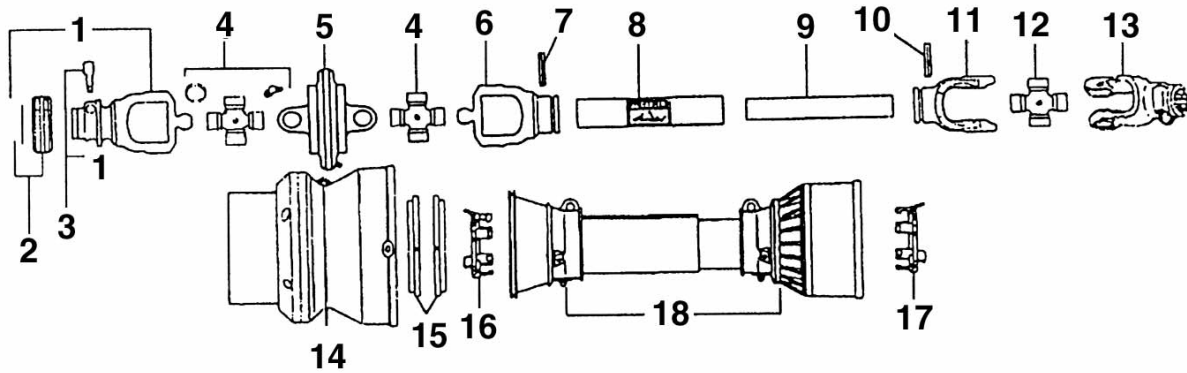

<u>REF#</u>	<u>QTY.</u>	<u>PART NO.</u>	<u>DESCRIPTION</u>
1	1	573040375	RS CV Yoke 1 3/8"
2	1	240080061	RS Collar
3	2	403000001	Complete Push Button
4	2	412040012	CV Cross Kit
5	1	511040051	CV Body
6	1	215046854	CV Outer Tube Yoke
7	1	341038000	Roll Pin
8	1	125161500	Outer Drive Tube
9	1	245101500	Inner Drive Tube
10	1	341048000	Roll Pin
11	1	204046852	Inner Tube Yoke
12	1	41204	Cross Kit
13	1	507040351	Yoke 1 3/8" 6 Spline
14	1	517048001	CV Hard Shell
15	1	255040351	Shield Bearing
16	1	255040005	Bearing Outer Tube
17	1	255040006	Bearing Inner Tube
18	1	5N0406IN6	Complete Shield w/o Hard Shell

# LIMITED WARRANTY



GEARMORE, INC., warrants each new Gearmore product to be free from defects in material and workmanship for a period of twelve (12) months from date of purchase to the original purchaser. This warranty shall not apply to implements or parts that have been subject to misuse, negligence, accident, or that have been altered in any way.

Our obligation shall be limited to repairing or replacement of any part, provided that such part is returned within thirty (30) days from date of failure to Gearmore through the dealer from whom the purchase was made, transportation charges prepaid.

This warranty shall not be interpreted to render us liable for injury or damages of any kind or nature, direct, consequential or contingent, to person or property. This warranty does not extend to loss of crops, loss because of delay in harvesting or any other expenses, for any other reasons.

Gearmore in no way warrants engines, tires, or other trade accessories, since these items are warranted separately by these respective manufacturers.

Gearmore reserves the right to make improvements in design or changes in specification at any time, without incurring any obligations to owners or units previously sold.

GEARMORE, INC.  
13477 Benson Ave.  
Chino, CA 91710

Always refer to and heed machine operating warning decals on machine.

*The serial number of this product is stored in our computer database, thus submitting a warranty registration card is not required.*