

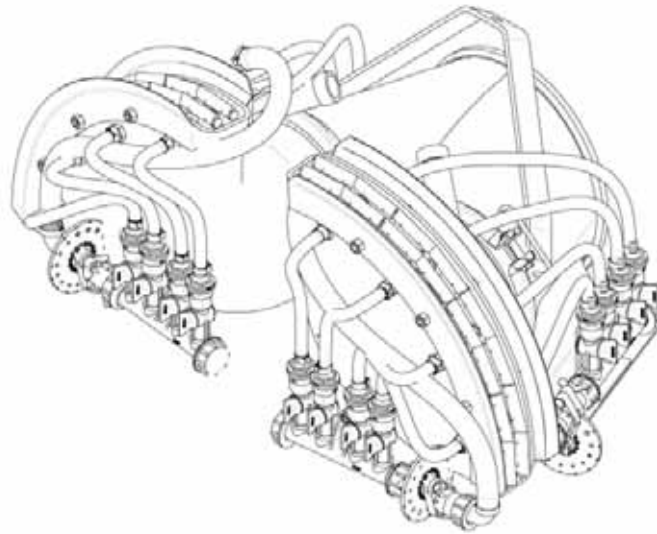

VENTURI AIR SPRAYERS ORCHARD HEAD



**Parts Manual For
T2V855T12 Orchard Head
For T55 Sprayers**

July 2013

TABLE OF CONTENTS

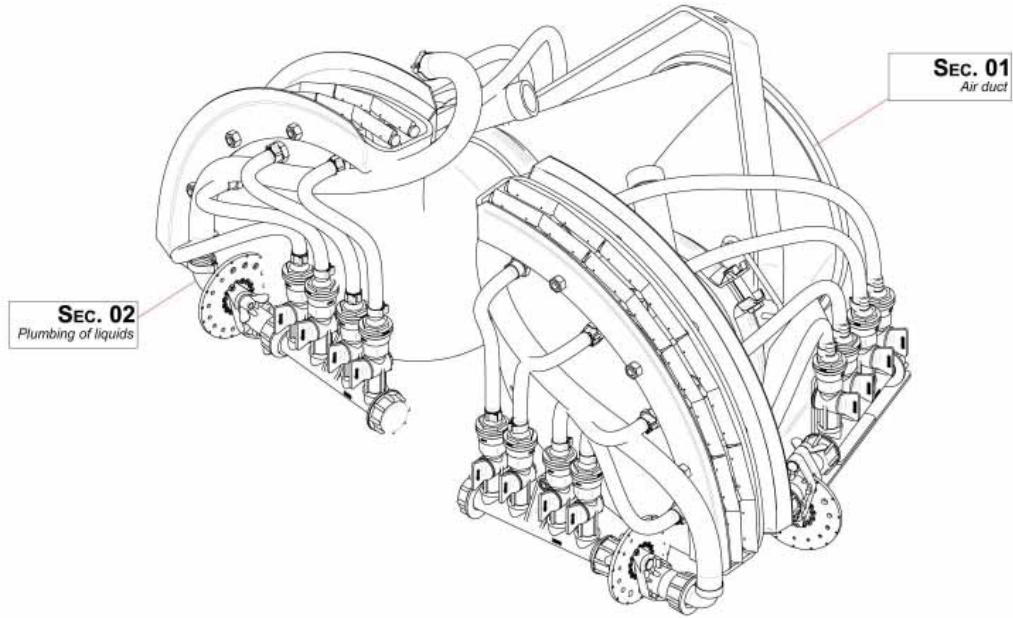

<u>SECTION</u>	<u>DESCRIPTION</u>	<u>PAGE</u>
1	Air Duct	1
2	Fishtail Parts	2
3	Liquid Plumbing	3
4	Manifold & Shut-Off Valves	4
5	Dial-A-Rate	5

Sec. 01 - AIR DUCT

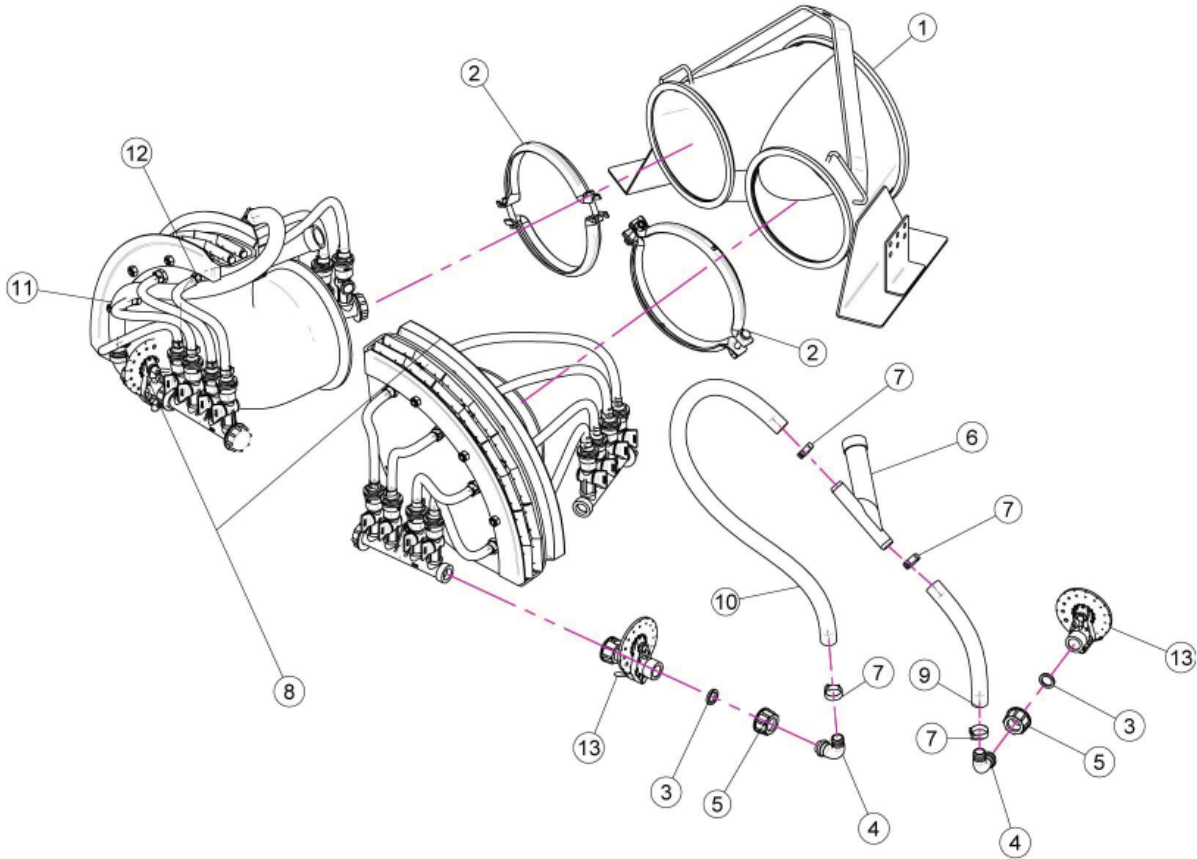

<u>REF.</u>	<u>QTY.</u>	<u>PART NO.</u>	<u>DESCRIPTION</u>
1	1	05.976.300	Body D.250 With 2 Outlets D.175
2	2	05.616.000	Pipe Clamp D.175
3	4	02.349.000	17 x 23 x 3 Flat Gasket
4	4	00.055.046	Curved Union With R.H. D.17
5	4	00.055.045	3/4" Fly Nut
6	2	02.123.000	35° Union With 2 Rubber Holder
7	8	FC.024.5.026	Hose Clamp 24.5 - 26
8	2	20.085.102C	D.175 Complete Fishtail
9	As Req'd	02.211.000	Hose D.16 x 23 L=200 (Per Foot)
10	As Req'd	02.211.000	Hose D.16 x 23 L=500 (Per Foot)
11	As Req'd	02.211.000	Hose D.16 x 23 L=500 (Per Foot)
12	As Req'd	02.211.000	Hose D.16 x 23 L=200 (Per Foot)
13	4	02.150.000	Rotation Disc Regulation

Sec. 02 - FISHTAIL PARTS

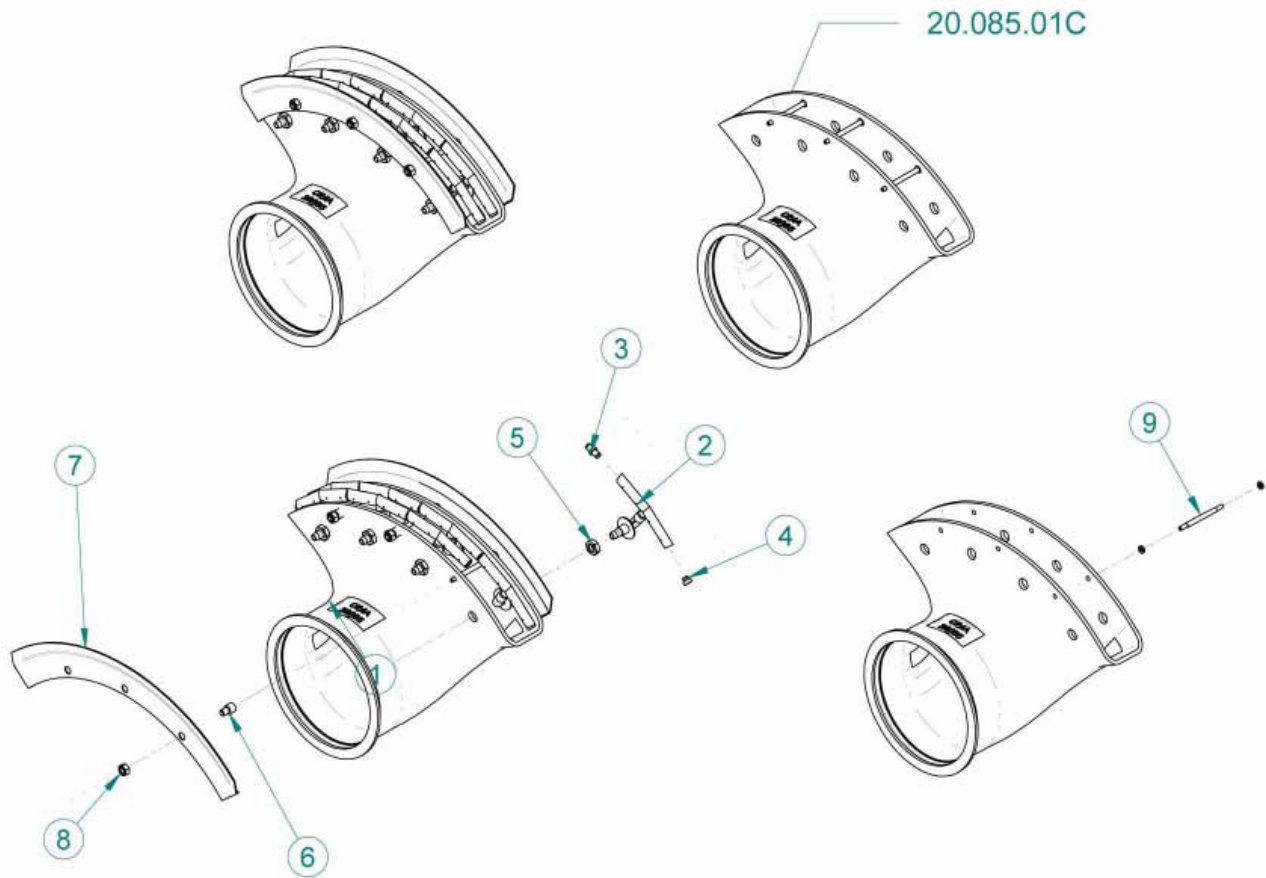

<u>REF.</u>	<u>QTY.</u>	<u>PART NO.</u>	<u>DESCRIPTION</u>
1	1	20.085.000	D.175 Fishtail
2	8	20.478.000	Pipe For Fishtails
3	6	20.082.000	Special Nipples For Copper Pipe
4	4	20.083.000	Short Tap For Pipe
5	8	DOT.12.5589	Lower Brass Nut M12
6	6	20.572.000	Male - Female Reduction
7	2	20.571.000	Fishtail Protection
8	6	DOT.08.5587	M8 Brass Nut
20.085.01C			
9	3	20.568.000	Stud Pin M5 L=77
10	6	RP.005.000	Washer D.5

Sec. 03 - PLUMBING OF LIQUIDS

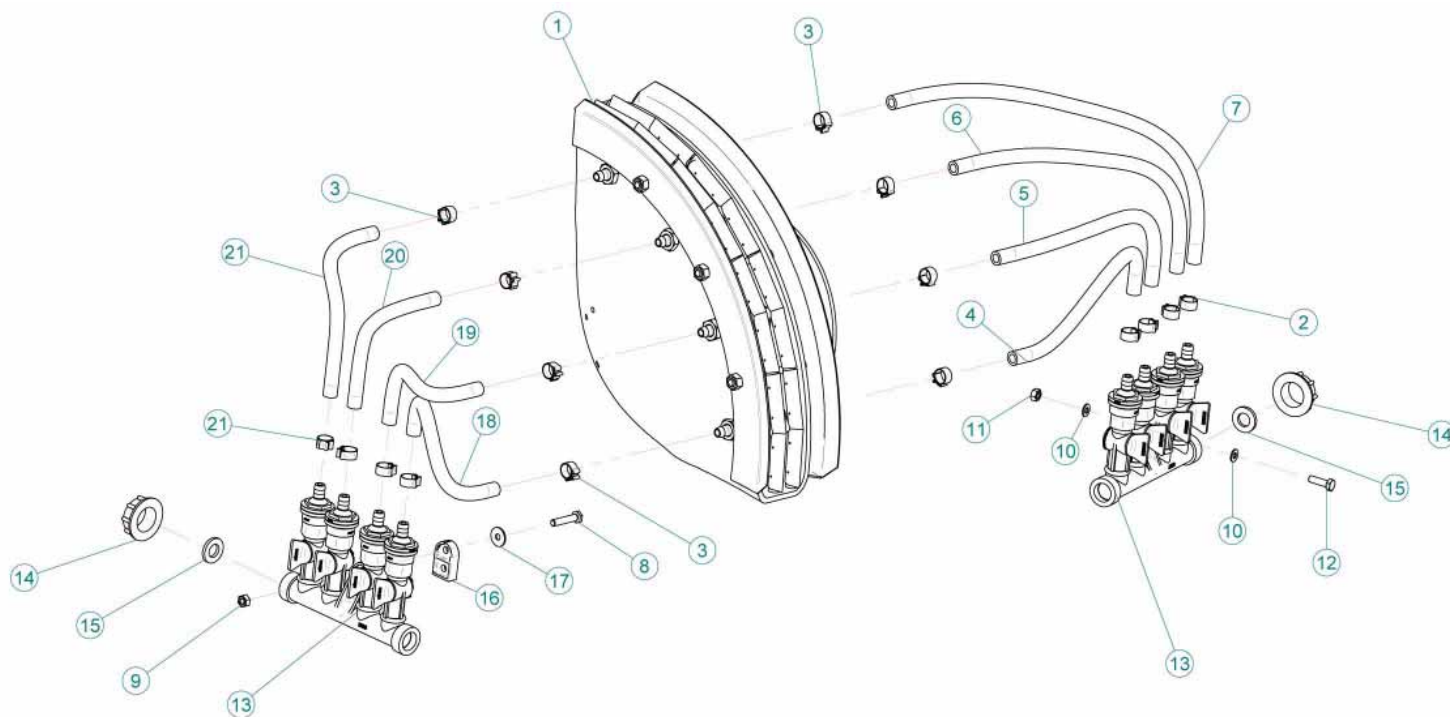

REF.	QTY.	PART NO.	DESCRIPTION
1	1	20.085.01C	D.175 Fishtail Complete With Pipes
2	8	FC.013.5.015	Hose Clamp
3	8	FC.012.5.014	Hose Clamp
4	As Req'd	02.217.000	Hose D.8 x 13 L=200 (Per Foot)
5	As Req'd	02.217.000	Hose D.8 x 13 L=230 (Per Foot)
6	As Req'd	02.217.000	Hose D.8 x 13 L=260 (Per Foot)
7	As Req'd	02.217.000	Hose D.8 x 13 L=290 (Per Foot)
8	2	TE.006.030I	INOX M6 x 30 Bolt
9	2	DOT.06.5587	M6 Brass Nut 5587
10	4	RP.006.000	Washer D.6
11	2	D0.06.5588G	Nut M6
12	2	TE.006.020T	Screw TE M6 x 20
13	2	02.008.304C	4 Taps Liquid Manifold
14	2	02.182.000	Female 3/4" Cap
15	2	02.030.010	Gasket
16	1	02.009.000	Spacer For Sprayheads Liquid Manifold
17	2	RP.006.018	Washer D.6 x 18
18	As Req'd	02.217.000	Hose D.8 x 13 L=200 (Per Foot)
19	As Req'd	02.217.000	Hose D.8 x 13 L=230 (Per Foot)
20	As Req'd	02.217.000	Hose D.8 x 13 L=260 (Per Foot)
21	As Req'd	02.217.000	Hose D.8 x 13 L=290 (Per Foot)

Sec. 04 - *MANIFOLD & SHUT-OFF VALVES*

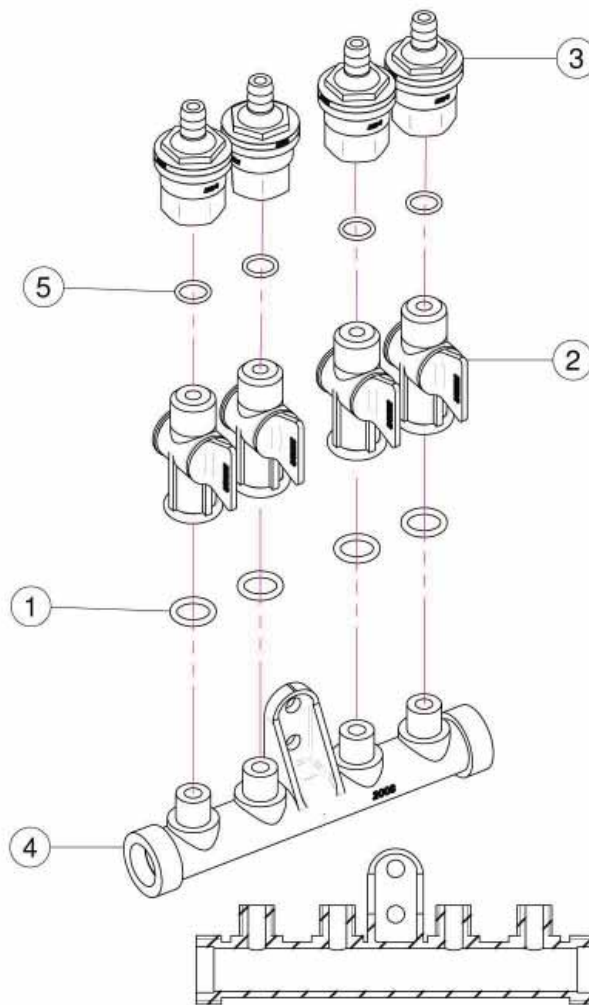

<u>REF.</u>	<u>QTY.</u>	<u>PART NO.</u>	<u>DESCRIPTION</u>
		02.008.304C	Complete Assembly
1	4	OR.000.117	13.1 x 18.34 x 2.62 O-Ring Gasket
2	4	20.202.100	Tap Assembly
3	4	00.227.01C	Anti-Drip Valve
4	1	02.008.000	Sprayheads Liquid Manifold
5	4	OR.002.043	10.82 x 14.38 x 1.78 Nbr 70 O-Ring Gasket

Sec. 05 - DIAL-A-RATE

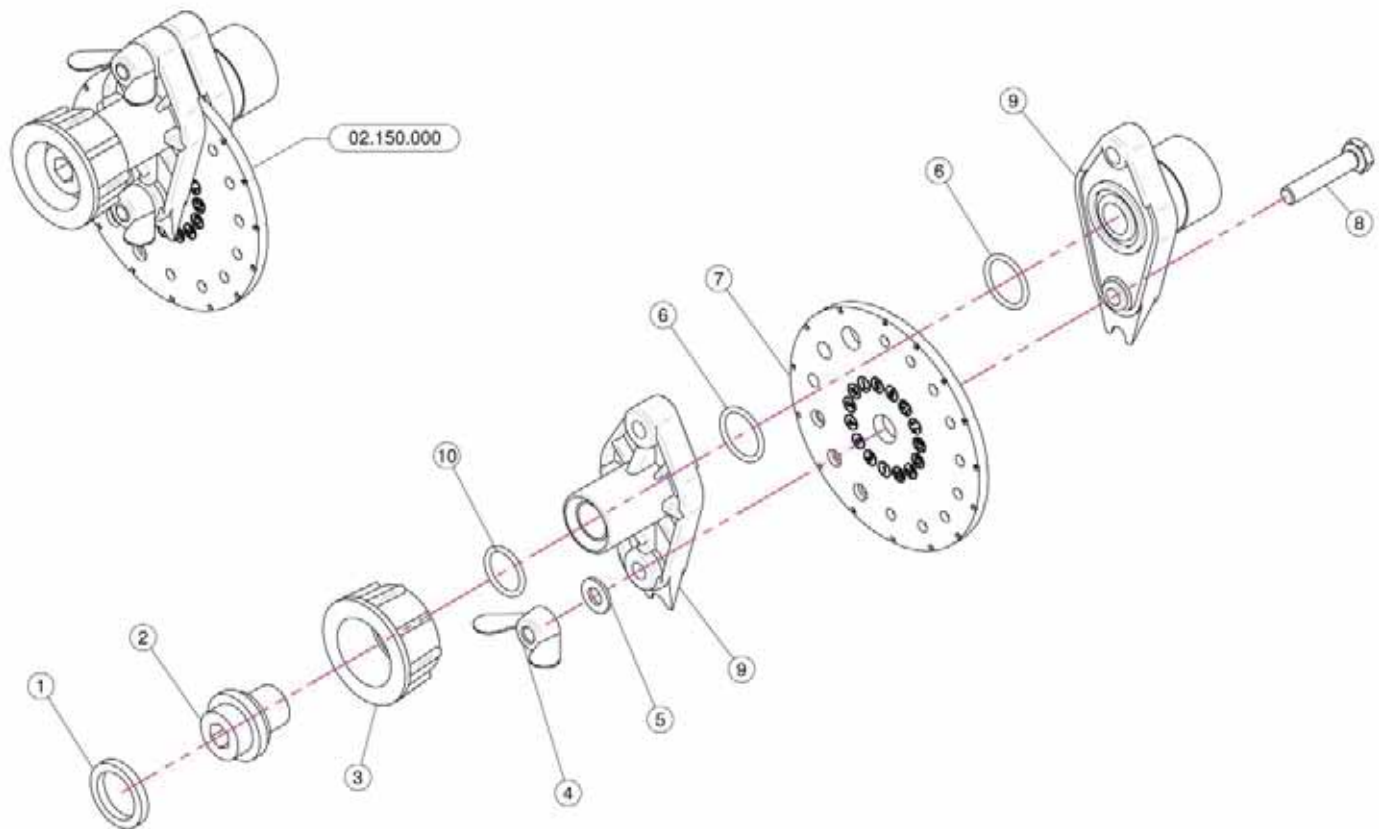

<u>REF.</u>	<u>QTY.</u>	<u>PART NO.</u>	<u>DESCRIPTION</u>
1	1	02.349.000	17 x 23 x 3 Flat Gasket
2	1	02.117.000	Adaptor Nipple
3	1	2002030	3/4" Fly Nut
4	2	DF.OTT.006	Wing Nut M6
5	2	RP.006.000I	INOX Washer D.6
6	2	OR1560178	D.15.6 x 1.78 O-Ring
7	1	02.148.000	Regulator Disc
8	2	TE.006.030I	INOX M6 x 30 Bolt
9	1	02.147.000	Regulator Body
10	1	OR1242178	O-Ring D.12.37 x 2.62