

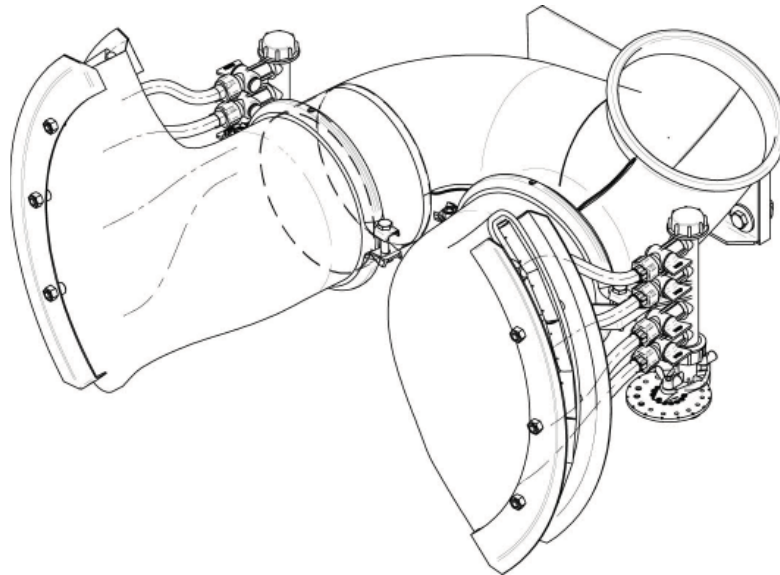

VENTURI AIR SPRAYERS ORCHARD HEAD



**Parts Manual For
T2V50P12 Orchard Head
For P50 Sprayers**

July 2013

TABLE OF CONTENTS

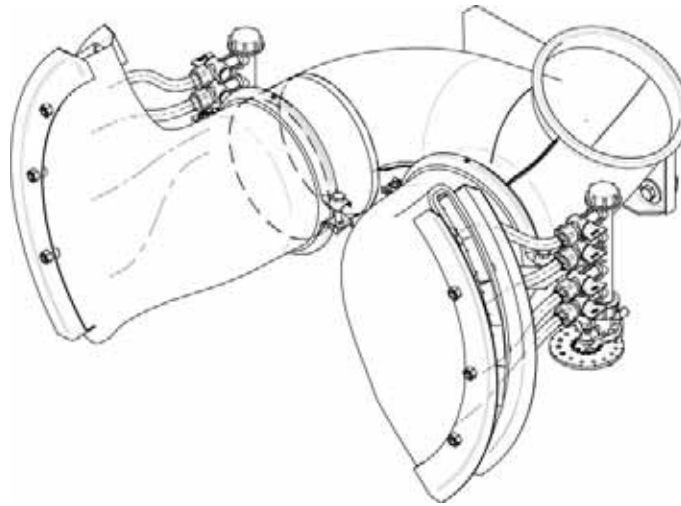

<u>SECTION</u>	<u>DESCRIPTION</u>	<u>PAGE</u>
1	Air Duct	1
2	Fishtail Parts	2-3
3	Manifold & Shut-Off Valves	4
4	Dial-A-Rate	5

Sec. 01 - AIR DUCT

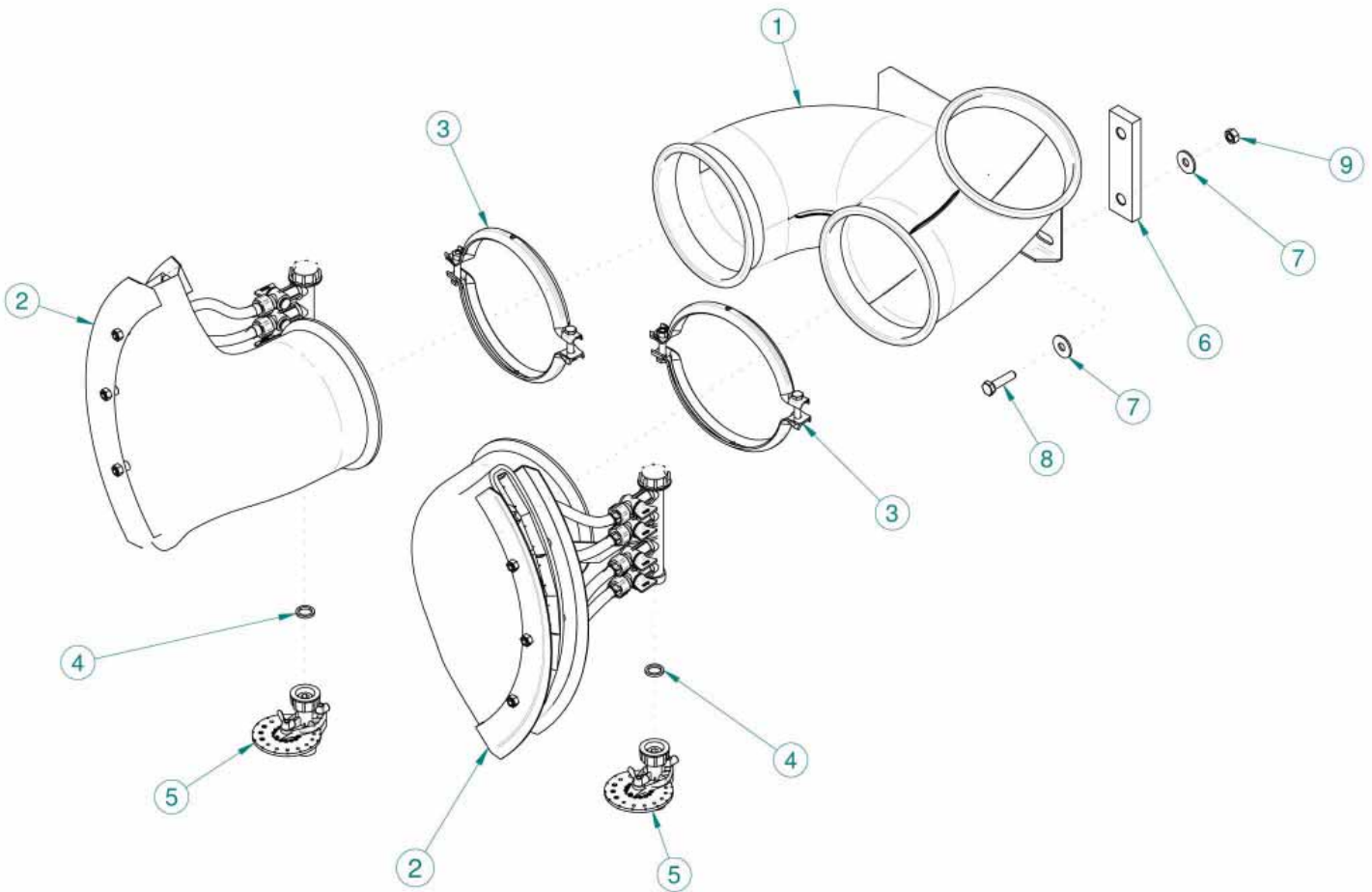

<u>REF.</u>	<u>QTY.</u>	<u>PART NO.</u>	<u>DESCRIPTION</u>
1	1	05.625.000	Body For 2 Fishtail Head
2	2	20.086.02C	Complete D.175 Fishtail
3	2	05.616.000	Pipe Clamp Ø 175
4	2	02.349.000	17 x 23 x 3 Flat Gasket
5	2	02.150.000	Rotation Disk Regulation
6	1	02.992.000	Bracket
7	4	RP.010.030	10 x 30 mm Large Flat Washer
8	2	TE.010.040T	Screw TE M10 x 40
9	2	DO.10.5587G	Nut M10

Sec. 02 - FISHTAIL PARTS

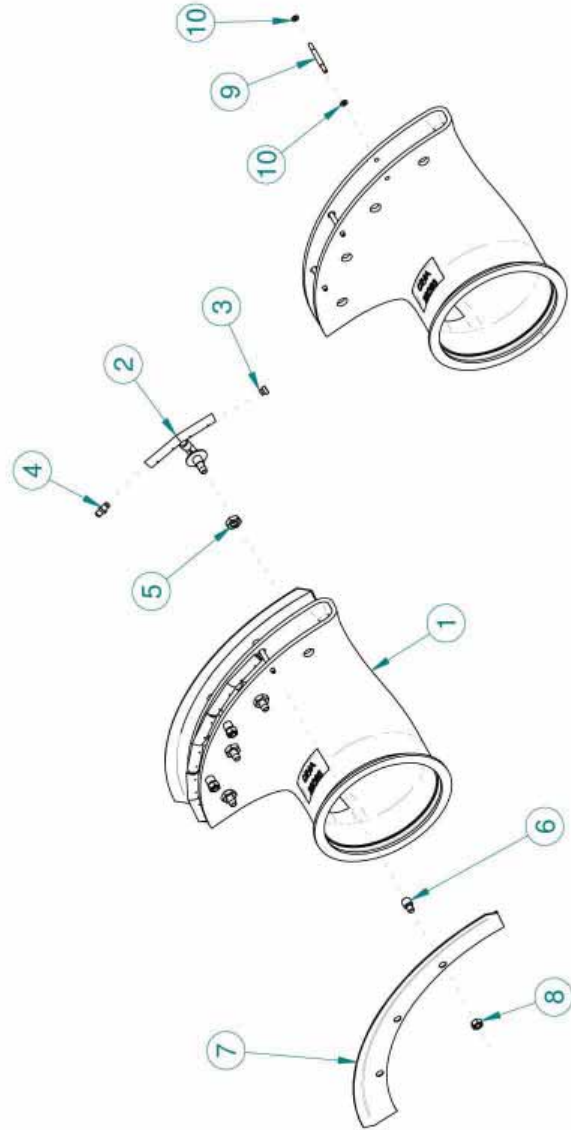
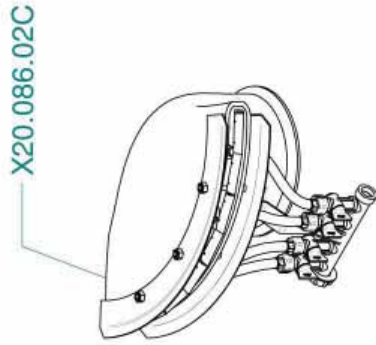
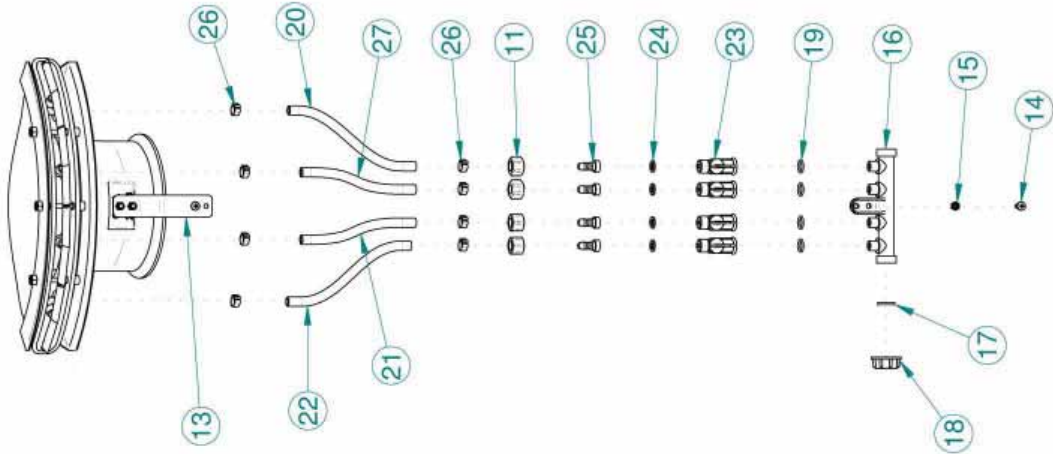

Sec. 02 - FISHTAIL PARTS

<u>REF.</u>	<u>QTY.</u>	<u>PART NO.</u>	<u>DESCRIPTION</u>
1	1	20.086.000	D.175 Fishtail
2	4	20.478.000	Pipe For Fishtails
3	2	20.083.000	Short Tap For Pipe
4	3	20.082.000	Special Nipples For Copper Pipe
5	4	DOT.12.5589	Lower Brass Nut M12
6	6	20.572.000	Male - Female Reduction
7	2	20.571.000	Fishtail Protection
8	6	DOT.08.5587	M8 Brass Nut
20.086.000			
9	3	20.567.000	Stud Pin M5 L=53
10	6	RP.005.000	Washer D.5
20.086.02C			
11	4	42.680.000	Rubber Holder Nut D.10
13	1	20.570.000	Fixing Distributor Bracket
14	4	TCC.06.16	Cross Slotted Screw M6 x 16
15	4	DOT.06.5588	M6 High Brass Nut 5587
16	1	02.008.000	Sprayheads Liquid Manifold
17	1	02.030.010	Gasket
18	1	02.182.000	Female 3/4" Cap
19	4	OR.000.117	13.1 x 18.34 x 2.62 O-Ring Gasket
20	1	02.217.000	Hose D.8 x 13 L=130 (Per Foot)
21	1	02.217.000	Hose D.8 x 13 L=110 (Per Foot)
22	1	02.217.000	Hose D.8 x 13 L=130 (Per Foot)
23	4	20.202.100	Tap Assembly
24	4	20.955.000	Plane Gasket Øe 16 - Øi 9
25	4	42.679.000	Rubber Holder D.10
26	8	FC.012.5.014	Hose Clamp
27	1	02.217.000	Hose D.8 x 13 L=110 (Per Foot)

Sec. 03 - MANIFOLD & SHUT-OFF VALVES

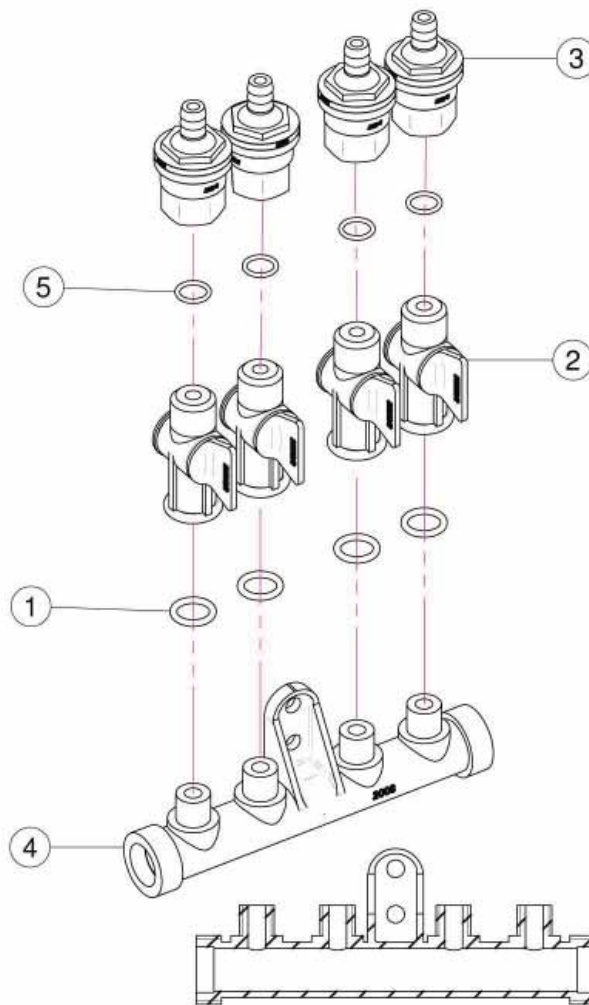

<u>REF.</u>	<u>QTY.</u>	<u>PART NO.</u>	<u>DESCRIPTION</u>
		02.008.304C	Complete Assembly
1	4	OR.000.117	13.1 x 18.34 x 2.62 O-Ring Gasket
2	4	20.202.100	Tap Assembly
3	4	00.227.01C	Anti-Drip Valve
4	1	02.008.000	Sprayheads Liquid Manifold
5	4	OR.002.043	10.82 x 14.38 x 1.78 Nbr 70 O-Ring Gasket

Sec. 04 - DIAL-A-RATE

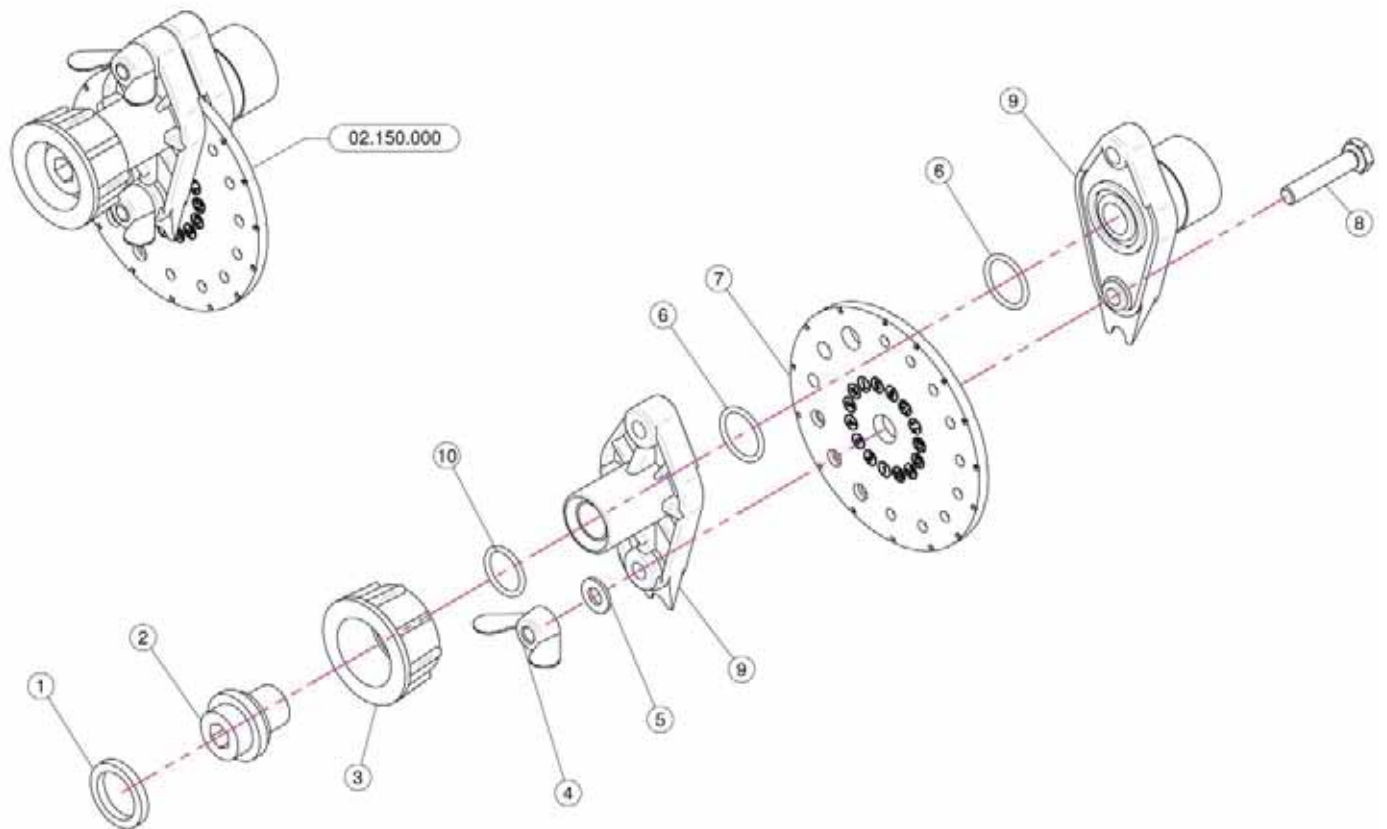

<u>REF.</u>	<u>QTY.</u>	<u>PART NO.</u>	<u>DESCRIPTION</u>
1	1	02.349.000	17 x 23 x 3 Flat Gasket
2	1	02.117.000	Adaptor Nipple
3	1	2002030	3/4" Fly Nut
4	2	DF.OTT.006	Wing Nut M6
5	2	RP.006.000I	INOX Washer D.6
6	2	OR1560178	D.15.6 x 1.78 O-Ring
7	1	02.148.000	Regulator Disc
8	2	TE.006.030I	INOX M6 x 30 Bolt
9	1	02.147.000	Regulator Body
10	1	OR1242178	O-Ring D.12.37 x 2.62