

GEARMORE INC.

LOG SPLITTERS

ENGINE DRIVEN, TRAILER MOUNTED

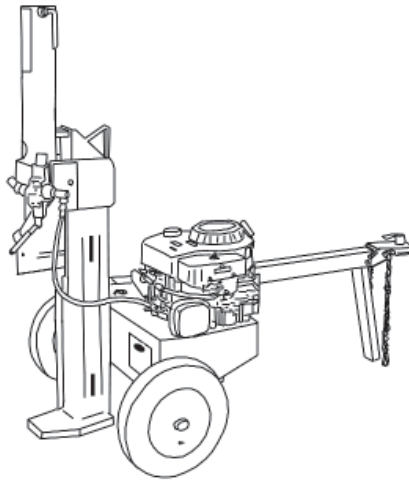

**Assembly, Parts
& Operator's Manual
For Models
T22B & T22H**

June 2006

TABLE OF CONTENTS

SECTION	DESCRIPTION	PAGE
1	Introduction	1
2	Safety.....	2
2.1	Training & Preparation.....	3
2.2	Safety Wear.....	3
2.3	Operating Safety.....	4
2.4	Operating Procedure	5
2.5	Repair & Maintenance Safety.....	5
2.6	Towing Safety	6
2.7	Fire Prevention	6
2.8	Hydraulic Safety	7
2.9	Safety Decals.....	7
3	Assembly Instructions.....	8
3.1	Assembly Guide	9-10
4	Operation	11
4.1	Engine Oil Recommendations.....	11
4.2	Filling Hydraulic System	12
4.3	Towing.....	12
4.4	Starting Instructions	12
4.5	Operation	13
5	Maintenance	14
6	Specifications	14
7	Parts Breakdown.....	15
7.1	Parts List.....	16-17
8	Limited Warranty.....	18

1 INTRODUCTION

Congratulations on your choice of Log Splitters. This equipment has been designed and manufactured to meet the needs of a discriminating buyer for the splitting of logs.

The Gearmore trailer mounted, engine driven log splitters are the latest compact designed splitters. The units are available with two different engines 6 H.P. Briggs and Stratton or 5.5 H.P. Honda. The log splitters can be used in the vertical or horizontal position. The 2" ball hitch allows the log splitter to be towed by ATVs, utility vehicles, small tractors, etc.

Safe, efficient and trouble free operation of your Log Splitter requires that you and anyone else who will be operating or maintaining the machine, read and understand the Safety, Operation, and Maintenance information contained within the Operator's Manual.

Keep this manual handy for frequent reference and to pass on to new operators or owners. Call your dealer, or us if you need assistance, information or additional copies of the manuals.

2 SAFETY

SAFETY ALERT SYMBOL

This Safety Alert symbol means **ATTENTION! BECOME ALERT! YOUR SAFETY IS INVOLVED!**



The Safety Alert symbol identifies important safety messages on the Log Splitter and in the manual. When you see this symbol, be alert to the possibility of personal injury or death. Follow the instructions in the safety message.

Why is SAFETY important to you?

3 Big Reasons

Accidents Disable and Kill

Accidents Cost

Accidents Can Be Avoided

SIGNAL WORDS:

Note the use of the signal words **DANGER**, **WARNING** and **CAUTION** with the safety messages. The appropriate signal word for each message has been selected using the following guide-lines:

DANGER - Indicates an imminently hazardous situation that, if not avoided, will result in death or serious injury. This signal word is to be limited to the most extreme situations typically for machine components which, for functional purposes, cannot be guarded.

WARNING - Indicates a potentially hazardous situation that, if not avoided, could result in death or serious injury, and includes hazards that are exposed when guards are removed. It may also be used to alert against unsafe practices.

CAUTION - Indicates a potentially hazardous situation that, if not avoided, may result in minor or moderate injury. It may also be used to alert against unsafe practices.

If you have any questions not answered in this manual or require additional copies or the manual is damaged, please contact your dealer.

2.1 TRAINING & PREPARATION

Before operating this Log Splitter, read and understand this manual completely. Become familiar with it for your own safety. To fail to do so may cause serious injury. **DO NOT** allow anyone to operate this Log Splitter who has not read this manual.



NEVER use your Log Splitter for any other purposes than splitting wood. It is designed for this use and any other use may cause an injury.

NEVER allow children to operate your Log Splitter nor adults lacking proper instructions. Keep them away from your work area. Your Log Splitter is not a toy. Only the operator is to be near your Log Splitter during use. Keep all others, including pets a minimum of 10 feet away from your work zone. Flying wood can be hazardous. If a helper is assisting in loading logs, **NEVER** activate the control until the helper is clear of the area. More accidents occur when more than one person operates the Log Splitter than at any other time.

NEVER operate your Log Splitter when under the influence of alcohol, drugs or medication. A clear mind is essential for safety.

NEVER allow a person who is tired or otherwise not alert to use your Log Splitter.

PREPARE LOGS PROPERLY

BOTH ends of each log should be cut as square as possible to help prevent the log from riding out of the splitter during operation.

2.2 SAFETY WEAR

NEVER wear loose clothing or jewelry that can be caught by moving parts of your Log Splitter and pull you into it. Keep clothing away from all moving parts of your Log Splitter. Wear proper head gear to keep hair away from moving parts.

ALWAYS wear safety shoes. A dropped log can seriously injure your foot.

ALWAYS wear safety glasses. A piece of splitting log could fly off and hit your eyes.



If you wear gloves, be sure they are tight fitting without loose cuffs or draw strings.

Have a first aid kit available should the need arise and learn how to use it.



ALWAYS wear protective hearing devices as needed.



PROLONGED EXPOSURE TO LOUD NOISE MAY CAUSE PERMANENT HEARING LOSS!

Tractors with or without equipment attached can often be noisy enough to cause permanent, partial hearing loss. We recommend that you wear hearing protection on a full-time basis if the noise in the Operator's position exceeds 80db. Noise over 85db on a long-term basis can cause severe hearing loss. Noise over 90db adjacent to the Operator over a long-term basis may cause permanent, total hearing loss. **NOTE:** Hearing loss from loud noise (from tractors, chain saws, radios, and other such sources close to the ear) is cumulative over a lifetime without hope of natural recovery.

2.3 OPERATING SAFETY

YOU are responsible for the **SAFE** operation and maintenance of your Log Splitter. **YOU** must ensure that you and anyone else who is going to operate, maintain or work around the Log Splitter be familiar with the operating and maintenance procedures and related **SAFETY** information contained in this manual. This manual will take you step-by-step through your working day and alerts you to all good safety practices that should be adhered to while operating the Log Splitter.

Remember, **YOU** are the key to safety. Good safety practices not only protect you, but also the people around you. Make these practices a working part of your safety program. Be certain that **EVERYONE** operating this equipment is familiar with the recommended operating and maintenance procedures and follows all the safety precautions. Most accidents can be prevented. Do not risk injury or death by ignoring good safety practices.

- Log Splitter owners must give operating instructions to operators or employees before allowing them to operate the machine, and at least annually thereafter per OSHA (Occupational Safety and Health Administration) regulation 1928.57.
- The most important safety feature on this equipment is a **SAFE** operator. It is the operator's responsibility to read and understand **ALL** Safety and Operating instructions in the manual and to follow these. Most accidents can be avoided.
- A person who has not read and understood all operating and safety instructions is not qualified to operate the machine. An untrained operator exposes himself and bystanders to possible serious injury or death.
- Do not modify the equipment in any way. Unauthorized modification may impair the function and/or safety and could affect the life of the equipment.
- **Think SAFETY! Work SAFELY!**

OPERATE IN SAFE ENVIRONMENT AND ON SAFE GROUND

1. **NEVER** operate your Log Splitter on slippery, wet, muddy or icy surfaces. Safe footing is essential in preventing accidents.
2. **ONLY** operate your Log Splitter on level ground and not on a side hill. It could tip over or rolling logs or poor footing could cause an accident. (This also prevents the spillage of gas from the tank).
3. **NEVER** attempt to move the Log Splitter over hilly or uneven terrain without a tow vehicle or adequate help.
4. **ALWAYS** block wheels to prevent movement of Log Splitter while in operation.
5. Keep work area clean. Immediately remove split wood around your Log Splitter so that you don't stumble over it.
6. When using your Log Splitter, use in daylight or under good artificial light.

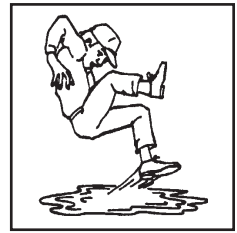

2.4 OPERATING PROCEDURE

- ◆ **ONLY** operate the Log Splitter from the operator zone.
- ◆ Know how to stop the unit and disengage the controls.
- ◆ **NEVER** place hands or feet between log and splitting wedge or between log and ram during forward or reverse stroke. To do so may result in crushed or amputated fingers *or worse*. **You may lose an arm or foot.**
- ◆ **DON'T** straddle the Log Splitter when using it. A slip in any position could result in a serious injury.
- ◆ **NEVER** try to split two logs on top of each other. One may fly out and injure you.
- ◆ **NEVER** allow one person to operate the valve while another is positioning the log, as serious injury could result from starting operation with the hands near the ram or wedge.
- ◆ **DON'T** step over Log Splitter when the engine is running. You may trip or accidentally activate the ram if you step over it. If you need to get to the other side, walk around.
- ◆ **NEVER** attempt to load your Log Splitter when the ram is in motion. You may get caught by the ram and injured.
- ◆ **ONLY** use your hand to operate the control lever. **NEVER** use your foot or a rope or any other extension device. This could result in your inability to stop your Log Splitter quickly and cause an injury.
- ◆ **NEVER** move the Log Splitter while the engine is running
- ◆ **NEVER** leave your Log Splitter unattended with the engine running. Shut off the engine if you are leaving your Log Splitter even for a short period of time. Someone could accidentally activate the ram and be injured.
- ◆ **DON'T** run the engine in an enclosed area. Exhaust gases contain carbon monoxide. This odorless gas can be deadly when inhaled.

2.5 REPAIR & MAINTENANCE SAFETY

Good maintenance is your responsibility. Poor maintenance is an invitation to trouble.

Follow good shop practices.

- Keep service area clean and dry.
- Be sure electrical outlets and tools are properly grounded.
- Use adequate light for the job at hand.

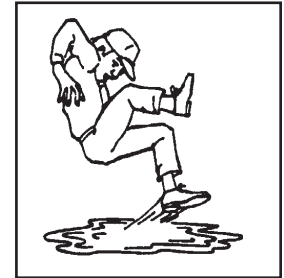

Make sure there is plenty of ventilation. Never operate the engine of the towing vehicle in a closed building. The exhaust fumes may cause asphyxiation.

A fire extinguisher and first aid kit should be kept readily accessible while performing maintenance on this equipment.



DON'T operate your Log Splitter in poor mechanical condition or when in need of repair.

PERIODICALLY check that all nuts, bolts and screws are tightened.

DON'T alter your Log Splitter in any manner, such as attaching a rope or extension to the control lever or adding to the width or height of the wedge unless approved by the manufacturer. Such alterations may cause your Log Splitter to be unsafe.

PERFORM all recommended maintenance procedures before you use your Log Splitter.

REPLACE all damaged or worn parts such as hydraulic hoses and fittings immediately.

NEVER tamper with the engine to run it at excessive speeds. This increases the hazard of personal injury. The maximum engine speed is preset by the manufacturer and is within safety limits.

DON'T service or repair your Log Splitter without removing the spark plug wire.

All replacement parts must meet manufacturer's specifications. The manufacturer will not be responsible for injuries or damages caused by use of unapproved parts and/or accessories.

2.6 TOWING SAFETY

OBEY all state and local regulations when towing on public roads and highways.

BEFORE towing, be certain that the Log Splitter is correctly and securely attached to the towing vehicle and that a safety chain is in place. Leave slack in chains for turning allowance.

DON'T allow anyone to sit or ride on your Log Splitter. They can easily fall off and be seriously injured.

BEFORE using your Log Splitter, disconnect it from the towing vehicle. A log can easily be pushed forward onto the vehicle.

NEVER carry any cargo or wood on your Log Splitter. It may fall off and endanger vehicles that are following you.

Allow for added length of your Log Splitter when turning, parking, crossing intersections and in all driving situations.

Be careful when backing up. You can easily jack-knife your Log Splitter.

Adjust towing speed for terrain and conditions. **DO NOT** exceed 45 MPH. Be extra cautious and reduce speed when towing over bumpy or rough terrain including railroad crossings.

2.7 FIRE PREVENTION

NEVER operate your Log Splitter near a flame or spark. Hydraulic oil and gasoline are flammable and can explode.

DO NOT fill the gas tank while the engine is hot or running. Allow the engine to cool before refueling.

NEVER smoke while operating or refueling your Log Splitter. Gas fumes can easily explode.

Only refuel your Log Splitter outdoors in a clear area void of gas fumes or spilled gas. Always use an approved fuel container. Always replace the gas cap securely.

If gasoline is spilled, move machine away from the area of the spill and avoid creating any source of ignition until the spilled gas has evaporated.

Take a Class B fire extinguisher with you when operating your Log Splitter in dry areas as a precautionary measure against possible flying sparks.



Completely drain the fuel tank prior to storage. This guards against the accumulation of fuel fumes, which could result in a fire hazard.

ALWAYS store gasoline in an approved, tightly sealed container. Store the container in a cool, dry place. **DO NOT** store in the house or near a heating appliance.

NOTE:

This unit is equipped with an internal combustion engine and should not be used on or near any unimproved forest covered, brush covered or grass covered land unless the engine's exhaust system is equipped with a spark arrester meeting applicable local or state laws (if any). If a spark arrester is used, it should be maintained in effective working order by the operator.

In the state of California, the above is required by law (Section 442 of the California Public Resources Code). Other states may have similar laws. Federal laws apply on federal lands. A spark arrester muffler (optional by manufacturer) is available as an accessory at your nearest engine dealer. Check legal requirements in your area.

2.8 HYDRAULIC SAFETY

The hydraulic system of your Log Splitter requires careful inspection along with the mechanical parts. Be sure to replace frayed, kinked, cracked or otherwise damaged hydraulic components. Just because it isn't leaking today doesn't mean that it will not fail tomorrow.

Fluid escaping from a very small hole can almost be invisible. Do not check for leaks with your hand. Escaping fluid under pressure can have sufficient force to penetrate skin causing serious personal injury or even death. Leaks can be detected by passing a piece of cardboard or wood over the suspected leak and looking for discoloration.



If injured by escaping fluid, see a doctor at once. Serious infection or reaction can develop if proper medical treatment is not administered immediately.

Should it become necessary to loosen or remove any hydraulic fitting or line, be sure to relieve all pressure by shutting off the engine and moving the control handle back and forth several times.

DO NOT remove the cap from the hydraulic tank or reservoir while your Log Splitter is running. Hot oil under pressure could result in serious injury.

The pressure relief valve on your Log Splitter is preset at the factory. **DO NOT** adjust the valve. Only a qualified service technician should perform this adjustment.

2.9 SAFETY DECALS



Part No. DL51-1-57

Location: Top, forward section of hydraulic cylinder

2.9 SAFETY DECALS



**ALWAYS REPLACE
MISSING OR
DAMAGED DECALS**



WARNING

1. READ AND UNDERSTAND OPERATOR'S MANUAL THOROUGHLY BEFORE OPERATION. FAILURE TO DO SO MAY RESULT IN SERIOUS INJURY.
2. KEEP ALL SHIELDS IN PLACE.
3. KEEP HANDS, FEET AND CLOTHING AWAY FROM POWER DRIVEN PARTS.
4. ALWAYS WEAR SAFETY GLASSES AND SAFETY SHOES DURING OPERATION.
5. ALWAYS OPERATE OUT-OF-DOORS WITH GOOD VENTILATION.
6. ALWAYS STOP ENGINE AND REMOVE SPARK PLUG WIRE BEFORE PERFORMING MAINTENANCE OPERATIONS.
7. ALWAYS SHUT OFF ENGINE WHEN LEAVING LOG SPLITTER UNATTENDED, EVEN FOR A SHORT PERIOD OF TIME.
8. ONLY ONE PERSON SHOULD LOAD AND OPERATE THE LOG SPLITTER. KEEP ALL OTHERS CLEAR DURING OPERATION. NEVER ALLOW ONE PERSON TO OPERATE VALVE WHILE ANOTHER IS POSITIONING THE LOG.
9. ALWAYS POSITION LOG WITH HANDS ON THE SIDES OF LOG. KEEP HANDS CLEAR OF ENDS.
10. KEEP ALL CHILDREN AWAY FROM THE LOG SPLITTER.
11. DO NOT STEP OVER THE LOG SPLITTER.
12. ONLY USE HANDS TO OPERATE THE CONTROL VALVE.
13. DO NOT OPERATE THE LOG SPLITTER WHILE UNDER THE INFLUENCE OF ALCOHOL, DRUGS OR MEDICATION.
14. ALWAYS OPERATE THE LOG SPLITTER ON LEVEL, DRY, NON-SLIPPERY SURFACES. KEEP OFF SLOPES.
15. KEEP WORK AREA CLEAR OF SPLIT WOOD, DEBRIS OR OTHER OBSTACLES.
16. ALWAYS STAY IN THE OPERATOR ZONE WHEN USING THE LOG SPLITTER.
17. ALWAYS SPLIT WOOD IN THE DIRECTION OF THE GRAIN ONLY.
18. DO NOT ADD GASOLINE WHILE THE ENGINE IS HOT OR RUNNING. ALLOW ALL SPILLED GAS TO EVAPORATE BEFORE USING LOG SPLITTER.

Part No. DL51-1-32

Location: Top of hydraulic cylinder

3 ASSEMBLY INSTRUCTIONS

NOTE:

The following instructions pertain to Gearmore Log Splitters, models T22B & T22H.

This Log Splitter comes partially assembled. Refer to the drawing and parts list should it become necessary to disassemble the unit for repair or replacement of parts.

STEP 1: Remove the top board from the crate. Leave the side board facing the tank and wheels in place. Remove the two end boards and the front board.



CAUTION: FLATTEN EXPOSED NAILS WITH A HAMMER TO AVOID POSSIBLE INJURY.

STEP 2: Remove the tongue assembly (3)* from the crate. Put the ground stand (34)* in the upright position and lock in place with pin (37)*.

STEP 3: Set one of the wood blocks from the crate underneath the tank (2)* so that it sits in the upright position.

STEP 4: Attach the tongue (3)* to the tank/axle assembly (2)* as shown in the diagram using the two $\frac{1}{2}$ " NC x 4 $\frac{1}{2}$ " hex cap screws (27)*, lockwashers (28)* and $\frac{1}{2}$ " NC hex nuts (30)* provided in the hardware kit. Flatwashers are included in the hardware kit should it be necessary to use them as spacers to eliminate play between the tongue and tank/tongue mounting plate. Tighten. The side board on the crate keeps the unit stable. Remove the board after this assembly step is complete.

STEP 5: Roll the tank/tongue assembly (2 & 3)* off the bottom board of the crate.

STEP 6: Remove the stripper plate (71)* from the beam (1)* and set it aside. Turn the beam assembly (1)* 90° and center it on the bottom of the crate. Then slide the cylinder (4)* back as far as possible from the beam foot plate until it locks.

STEP 7: Attach the stripper plate (71)* to the

beam. You may need to wiggle the plate back and forth until the holes line up. Use the $\frac{3}{8}$ " bolts and $\frac{3}{8}$ " lockwashers provided in the hardware kit. Place the $\frac{3}{8}$ " flatwashers provided in the hardware kit in front of the lockwashers next to the hole. Push the stripper plate (71)* down until there is no play in the bolts. Tighten.

STEP 8: Slide the beam (1)* off the bottom of the crate and carefully set it upright. Roll the tank/tongue assembly (2 & 3)* into position between the two tabs on the beam (1)* as shown in the diagram. Slide the pivot pin (25)* through the holes and secure with clip pin (26)*.

STEP 9: Lower the beam (1)* to the horizontal position so that the hole in the beam fits over the pin (32)* on the tongue (3)*. Lock in place with the lynch pin (31)* provided in the hardware kit.

STEP 10: Connect the $\frac{3}{4}$ " I.D. x 35" return hose (53)* to the $\frac{3}{4}$ " NPT x $\frac{3}{4}$ " tube fitting on the valve (5)*. Tighten hose clamp (18)*. Remove the plastic plug from the other valve port and connect the $\frac{1}{2}$ " I.D. pressure hose coming from the pump (9)* to the swivel elbow fitting (50)* on the valve (5)*. Tighten the nut securely.

STEP 11: Remove the pin and cotter from the valve (5)* handle. Put the handle in the upright position and secure with pin and cotter.

* See *Parts Breakdown* (Pages 15 - 17) in this manual.

3.1 ASSEMBLY GUIDE

LOG SPLITTER ASSEMBLY GUIDE

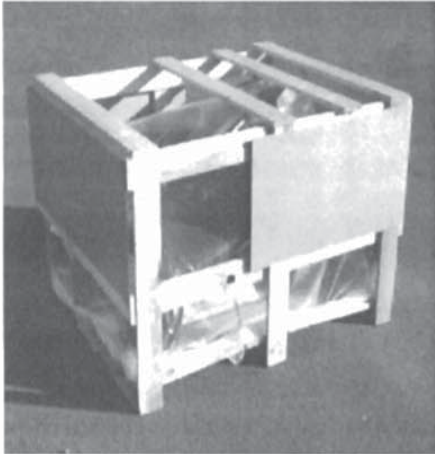

Compact Log Splitter in crate.

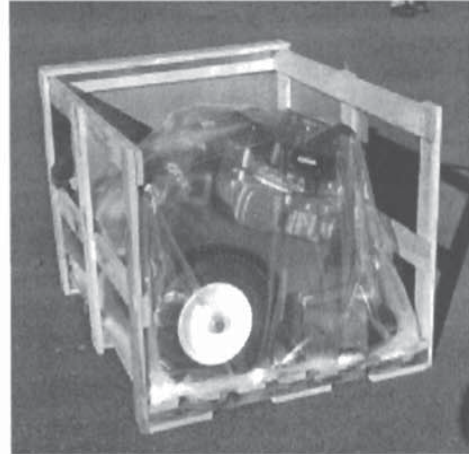

Crate with top and end piece removed (see Step 1, pg. 8).

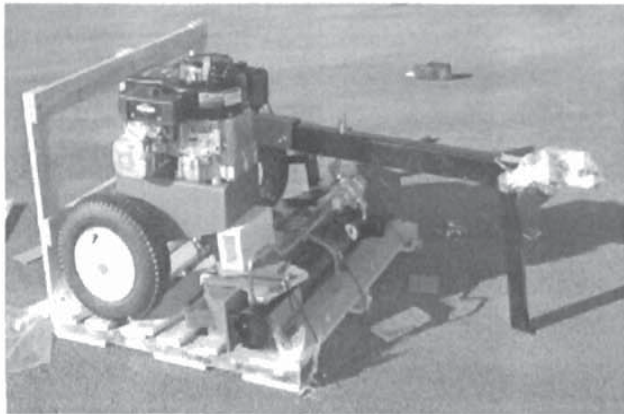

Crate with side board in place to provide support. (see steps 1 - 4, pg. 8). Wood block under tank to keep it upright.

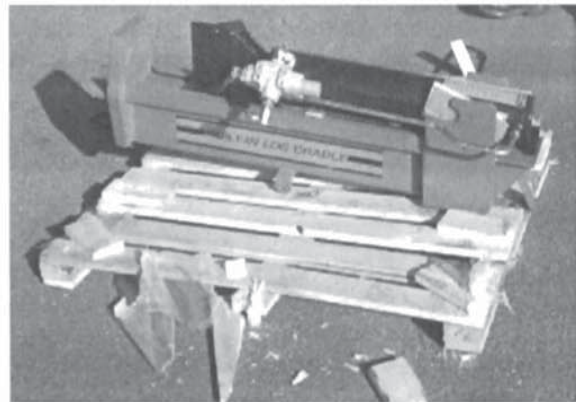

Beam rotated and centered on bottom of crate (see steps 5 - 6, pg. 8).



Cylinder pushed all the way back and stripper plate attached (see steps 6 - 7, pg. 8).

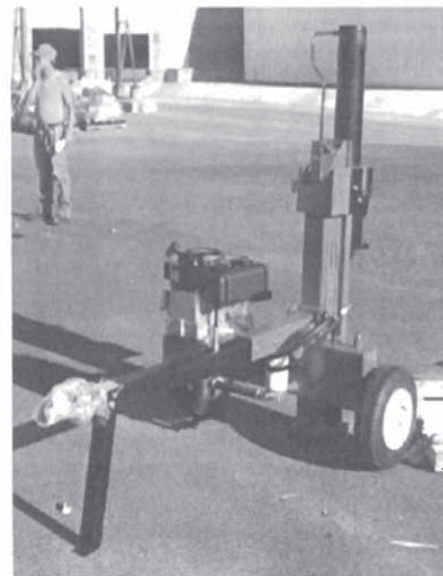

Beam attached to tank/tongue assembly (see step 8, pg. 8).

3.1 ASSEMBLY GUIDE

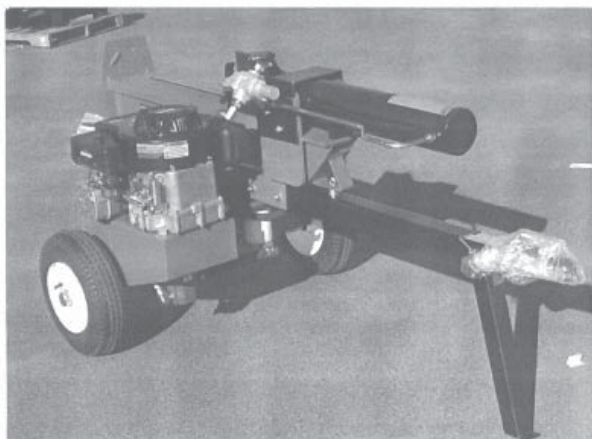

Log Splitter locked down in horizontal position (see step 9, pg. 8).

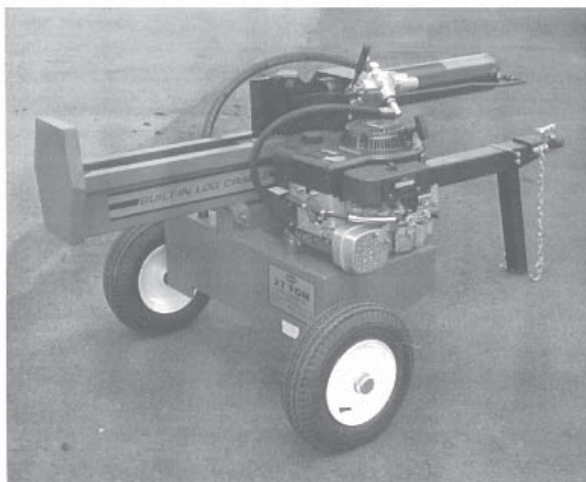

Log Splitter with hoses connected and valve handle in position (see steps 10 - 11, pg. 8).

4 OPERATING INSTRUCTIONS

STEP 1: Starting



CAUTION: DO NOT START OR RUN THE ENGINE WITHOUT OIL IN THE HYDRAULIC RESERVOIR AND ENGINE.

IMPORTANT: The engine and hydraulic tank are shipped without oil. See the engine operating and maintenance instructions manual packed with your Log Splitter for the type of crankcase oil, fuel, etc. The engine manufacturer recommends lead-free gasoline only.



CAUTION: DO NOT START OR RUN THE ENGINE BEFORE READING ALL OPERATING INSTRUCTIONS AND NOTES ON SAFETY THOROUGHLY.

STEP 2: The hydraulic reservoir should be filled with an SAE20 hydraulic oil. If hydraulic oil is difficult to obtain, automatic transmission fluid can be substituted and *should be used instead of hydraulic oil when temperatures are below 32° F*. Use only clean oil and take care to prevent dirt from entering the hydraulic reservoir.



CAUTION: WHEN TIGHTENING THE BREATHER CAP ON THE TANK, POINT THE HOLE AWAY FROM THE ENGINE AND THE OPERATOR ZONE.

4.1 ENGINE OIL RECOMMENDATIONS

BRIGGS & STRATTON ENGINES:

For temperatures above 40° F use an SAE30W oil. Using multigrade oil may increase oil consumption. Using SAE 30W oil below 40° F will result in hard starting and possible engine bore damage. For temperatures below 40° F use an SAE10W-30 or SAE5W-30 oil. Oil capacity for the 6 H.P. engine is approximately $\frac{5}{8}$ quart (20 ounces; 0.6 liter). Refer to Briggs & Stratton engine owner's manual for additional information.

HONDA ENGINES:

For temperatures above 50° F, use an SAE30W oil. Using multigrade oil may increase oil consumption. For temperatures below 50° F use an SAE10W-30 oil. Using SAE30W oil below 40° F may result in hard starting and possible engine bore damage due to inadequate lubrication. SAE10W-30 is recommended for general use. Refer to the Honda engine owner's manual. Oil capacity is 0.58 quart (19 ounces; 0.55 liter).

ALWAYS check oil level before starting the engine. Keep oil level at full.

4.2 FILLING HYDRAULIC SYSTEM

Fill the hydraulic reservoir with at least four gallons of hydraulic fluid. After the hydraulic reservoir and the engine crankcase are filled with oil, start the engine. The hydraulic pump should prime itself. With the engine running, move the hydraulic valve lever toward the wedge. This will cause the cylinder to extend and expel air. When the cylinder is fully extended, retract it. Repeat this procedure several times. An erratic movement of the cylinder indicates that there is still air in the system. More oil should then be added to bring the fluid level up to the "OK" range on the dipstick. Total hydraulic capacity is 5 gallons.

NOTE: If the tank is overfilled, it will tend to expel oil from the breather cap when the cylinder is retracted. After adding more oil to the tank, cycle the cylinder again until it has a constant speed indicating that all oil has been expelled. Check the oil level in the reservoir again with the dipstick to make sure it is in the "OK" range.

4.3 TOWING

The Log Splitter is equipped with road speed tires, a Class I coupler (2" diameter ball required) and safety chains. Before towing, the safety chains must be secured to the hitch or bumper of the vehicle. Local regulations should be checked regarding licensing, lights, towing, etc. *See also Towing Safety in the Safety information section of this manual.*

When transporting the machine, review and follow these instructions:

1. Be sure all bystanders are clear of the machine.
2. Be sure that the machine is securely attached to the tow vehicle.
3. Be sure you are in compliance with all applicable lighting and marking regulations when transporting. Check with your local authorities.
4. Be sure your machine can clearly be seen by overtaking and oncoming traffic.
5. **NEVER** allow riders on your Log Splitter.
6. **DO NOT** drink and drive.

4.4 STARTING INSTRUCTIONS

HONDA 5.5 H.P. ENGINE

1. To start a cold engine, turn the fuel valve to the "ON" position.
2. Move the choke to the "ON" position.
3. Move the throttle control to the "FAST" position.
4. Pull the starter grip slightly until resistance is felt. Then pull rapidly to start engine.
5. Move the choke lever to the "OFF" position, if it was used to start the engine, as soon as it warms up enough and is running smoothly.
6. When the engine starts, move the throttle to the "FAST" position. It is recommended that the engine be operated in the "FAST" position for maximum performance.
7. To stop the engine, move the throttle lever to the "SLOW" position and then to the "STOP" position. Turn fuel valve to "OFF"

BRIGGS & STRATTON 6 H.P. ENGINE

1. Move control lever to "FAST".
2. Push primer bulb three (3) times.
NOTE: Do not use primer to restart a warm engine after a short shutdown.
3. Grasp starter rope handle and pull out slowly until resistance is felt. Then pull rapidly with a full arm stroke.
NOTE: If engine fails to start after three (3) pulls, repeat instructions 1 and 2.
4. When engine starts, leave control lever at "FAST". The throttle must be in the "FAST" position for maximum performance.
5. To stop the engine, move the throttle lever to "SLOW" and then to "STOP".

NOTE:

To start a warm engine, move the throttle lever to the "FAST" position and then pull the starter grip until the engine starts.

The engine maximum governed speed is preset at the factory at 3600 RPM, no load speed. When splitting wood, the throttle should be set at the maximum setting to develop the horsepower required for the pump.

4.5 OPERATION



WARNING: ALWAYS WEAR SAFETY GLASSES DURING OPERATION

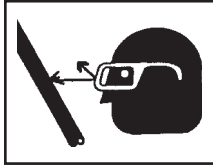

DANGER: KEEP HANDS AND FEET CLEAR OF RAM, STRIPPER PLATES AND BASE PLATE AT ALL TIMES.

1. Set up the Log Splitter in a clear, level area and block the wheels. Make sure that the suction port on the tanks is always on the lower side of the Log Splitter.
2. Place a log on the beam against the foot plate. Make sure that the log is securely on the foot plate and up against the beam.

Both ends of each log should be cut as square as possible to help prevent the log from riding out of the splitter during operation.

3. Depress the valve handle so that the cylinder will drive the wedge into the log. Extend the cylinder until the log splits or to the end of its stroke. If the log has not completely split after the cylinder has reached the end of its extension, retract the cylinder.

IMPORTANT: Leaving the valve in the "actuate" position at the end of the stroke may damage the pump. Always use extra care when splitting logs with unsquare ends.

NOTE: For operation in wooded areas, obtain a spark arrester for the exhaust system. See the engine operating and maintenance manual and check with your authorized Briggs & Stratton or Honda service center. *See also Fire Prevention in the Safety Information Section of this manual.*

IMPORTANT:

TO EXTEND THE LIFE OF THE HYDRAULIC CYLINDER, AVOID "BOTTOMING OUT" WEDGE PLATE TO THE FOOT PIECE. TO CONFORM WITH INDUSTRY SAFETY RECOMMENDATIONS, THE WEDGE STOPS 2 INCHES FROM THE END OF THE STROKE.

5 MAINTENANCE

By following a good maintenance program, your equipment will last for many years.

1. Consult the operating and maintenance instructions of the engine manufacturer for engine care and maintenance.
2. Always check the oil level of the hydraulic reservoir before operation. Operating the Log Splitter without an adequate oil supply will cause severe damage to the pump.
3. Change the oil filter after the first 25 hours of operation. Thereafter, change the oil filter every 100 hours or seasonally, whichever comes first.
4. If the wedge becomes dull or nicked, a grinder or sharpening tool can be used to sharpen it while still attached to the cylinder. If it is necessary to remove the wedge, the stripper plate (71)* must be taken off by removing the $\frac{3}{8}$ " bolts (68)*. Then remove the cylinder support (66)* by taking out the $\frac{3}{8}$ " bolts (63)*. Then remove the $\frac{1}{2}$ " x $3 \frac{1}{2}$ " bolt (51)* that connects the wedge to the cylinder. The return hose (53)* may need to be disconnected from the valve. Loosen hose clamp (18)* and pull the hose off the fitting. Lift up the cylinder carefully and slide the wedge out of the channel.
5. Clean the breather cap after 25 hours of operation. Clean it more often when operated in dusty conditions. To clean, remove the breather from the tank and flush with kerosene or liquid detergent to remove the dirt.
6. See also Repair and Maintenance Safety in the Safety Information section of this manual.
7. All replacement parts must meet manufacturer's specifications.

* See *Parts Breakdown* (Pages 15-17) in this manual.

6 SPECIFICATIONS

Splitting Force:	22 Tons
Beam Size:	6" x 6"
Cylinder Size:	4" x 24"
Valve Type:	Auto-Return
Pump:	2-Stage, 11 GPM
Engine:	Honda 5.5 H.P. or Briggs & Stratton 6 H.P.
Filter:	Replaceable
Hoses & Fittings:	Included
Tires:	4.80 x 8" Road Speed
Safety Chains:	Included
Ground Stand:	Included
Coupler:	2" Ball
Wedge Height:	7"
Cycle Time:	13 Seconds
Max. Log Length:	26"
Total Reservoir Capacity:	17 Quarts
Height:	39" Horizontal 62" Vertical
Length:	77 $\frac{1}{2}$ "
Width:	44"
Built-In Log Cradle:	Yes
Shipping Weight:	T22H - 430 lbs. T22B - 430 lbs.

- Ideal case cycle times. Actual cycle times vary depending on temperature, engine speed, pump efficiency, altitude, etc.

7 PARTS BREAKDOWN

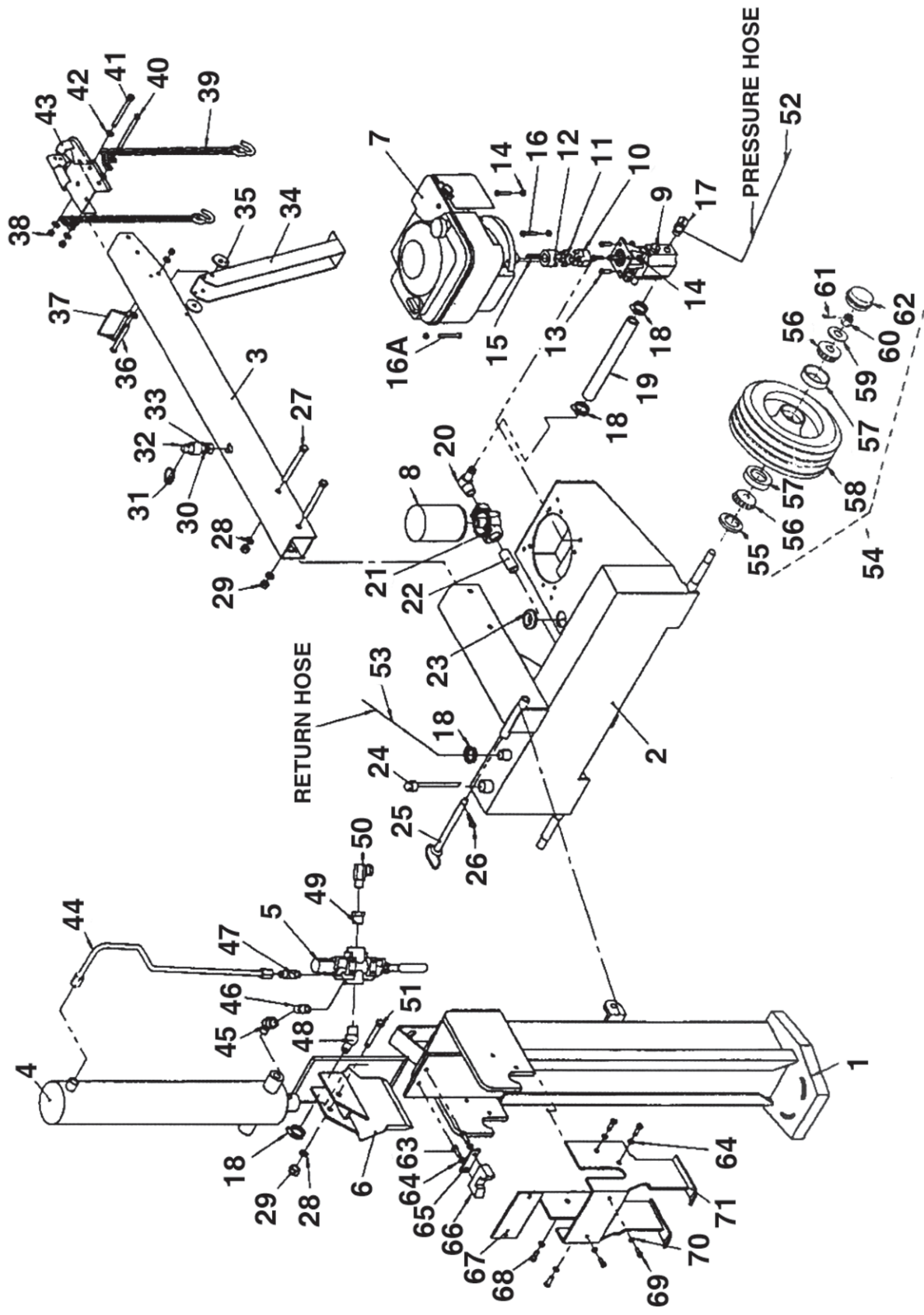

7.1 PARTS LIST

<u>REF #</u>	<u>QTY.</u>	<u>PART NO.</u>	<u>DESCRIPTION</u>
		LS401301	22 Ton Compact Log Splitter w/B & S 6 H.P. Engine
		LS401302	22 Ton Compact Log Splitter w/Honda 5.5 H.P. Engine
1	1	LS401348	Beam
	1	LS401345	Complete Beam Assembly
2	1	LS401340	Tank/Axle
3	1	LS401338	Tongue
4	1	HC390129	4" Hydraulic Cylinder
5	1	HC390406A	Auto-Return Valve
6	1	LS401136	Wedge
7	1	HC390529	6 H.P. Briggs & Stratton Engine
	1	HC390532	5.5 H.P. Honda Engine
8	1	HC390601	Filter Assembly Complete
	1	HC390601A	Filter Element (see list of equivalent filter elements)
	1	HC390601B	Filter Base
9	1	HC390705B	11 GPM Pump
10	1	LS400833L	1/2" I.D. Coupler Half (pump side)
11	1	LS400834L	Coupler Spider
12	1	LS400838L	7/8" I.D. Coupler Half (engine side)
	1	LS400837	Complete Coupler
13	4	Obtain Locally	5/16" x 1" Grade 5 Hex Cap Screw
14	7	Obtain Locally	5/16" NC Locknut
15	1	LS400321	3/16" Square Engine Key
16	3	Obtain Locally	5/16" NC x 1 1/2" Hex Cap Screw T22H
	2	Obtain Locally	5/16" NC x 1 1/2" Hex Cap Screw T22B
16A	1	Obtain Locally	5/16" NC x 2 1/2" Hex Cap Screw T22B
17	1	HC390341	1/2" x 90° Street Elbow
18	4	HC390316	Worm Gear Clamp
19	1	HC390255	3/4" x 11" Suction Hose
20	1	HC390320	3/4" NPT x 3/4" Hose Fitting
21	1	HC390601B	Filter Base
22	1	HC390349	3/4" x 2 1/2" Nipple
23	1	LS401174	1 1/4" I.D. Grommet
24	1	LS400429	Breather Cap w/Dipstick
25	1	P71022WC	5/8" x 6" Pivot Pin
26	1	Obtain Locally	1/8" "R" Clip Pin
27	2	Obtain Locally	1/2" NC x 4 1/2" Hex Cap Screw
28	3	Obtain Locally	1/2" Lockwasher
29	3	Obtain Locally	1/2" NC Hex Nut
30	1	Obtain Locally	5/8" Lockwasher
31	1	P794	1/4" Lynch Pin
32	1	P7810A	Stabilizer Pin
33	1	Obtain Locally	5/8" NF Hex Nut
34	1	LS401339	Ground Stand
35	2	HW17322	1 3/4" O.D. x .44" I.D. x 3.5mm Washer
36	1	HW172718	M10 x 1.5 x 85mm Bolt

7.1 PARTS LIST

<u>REF #</u>	<u>QTY.</u>	<u>PART NO.</u>	<u>DESCRIPTION</u>
37	1	P7958	Locking Pin
38	3	HW172809	M10 x 1.5 Lock Nut
39	2	LS400323	12" Safety Chain w/"S" Hooks
	2	LS400345	"S" Hook
40	1	HW172717	M10 x 1.5 x 115mm Bolt
41	1	HW172716	M10 x 1.5 x 100mm Bolt
42	8	HW172908	10mm Washer
43	1	LS400346	Hitch Coupler for 2" Ball
44	1	HC390369	1/2" Steel Tube
45	1	HC390368	1/2" NPT Female x 1/2" NPT Male 45° Elbow
46	1	HC390343	1/2" x 1/2" Nipple
47	1	HC390347	Steel Tube Fitting
48	1	HC390324	3/4" NPT x 3/4" Tube 45°
49	1	HC390311	3/4" to 1/2" Reducer
50	1	HC390302	Swivel Elbow 90°
51	1	Obtain Locally	1/2" NX x 3 1/2" Grade 5 Hex Cap Screw
52	1	HC390329	1/2" I.D. x 42" Hydraulic Pressure Hose
53	1	HC390256	3/4" I.D. x 35" Hydraulic Return Hose
54	2	LS400312B	Pre-greased Wheel Assembly
55	2	BE22176	Grease Seal
56	4	BE22175	Bearing Cone
57	4	BE22174	Bearing Cup
58	2	LS400312	4.80 x 8" Road Speed Tire
59	2	Obtain Locally	3/4" Light Flat Washer
60	2	HN17120	3/4" NF Slotted Nut
61	2	Obtain Locally	1/8" x 1 1/2" Cotter Pin
62	2	LS400332	Hub Cap
63	2	Obtain Locally	3/8" NC x 1 1/2" Bolt
64	6	Obtain Locally	3/8" Lockwasher
65	1	LS401353	Cylinder Support Plate
66	1	LS401349	Cylinder Support
67	1	LS401354	Stripper Plate
68	4	Obtain Locally	3/8" NC x 1" Grade 5 Hex Cap Screw
69	2	Obtain Locally	5/16" x 3/4" Hex Cap Screw
70	2	Obtain Locally	5/16" Lockwasher
71	1	LS401352	Stripper Assembly
	1	LS401155	Hardware Kit

REPLACEMENT FILTER CARTRIDGE

<u>HC390601 INTERCHANGES WITH:</u>	<u>REPAIR KITS:</u>	<u>DESCRIPTION:</u>
FRAM 1653A	HC390423A	O-Ring Kit for Valves HC390406A & HC390406S
NAPA 1553	HC390720B	O-Ring Kit for Pumps HC390705B & HC390709
Cross #1A9023	HC390120F	O-Ring Kit for 4" x 24" Cylinder
Baldwin #BT839	HC390171	O-Ring Kit for 4 1/2" x 24" Cylinder
Wicks #51553		

8 LIMITED WARRANTY



GEARMORE, INC., warrants each new Gearmore product to be free from defects in material and workmanship for a period of twelve (12) months from date of purchase to the original purchaser. This warranty shall not apply to implements or parts that have been subject to misuse, negligence, accident, or that have been altered in any way.

Our obligation shall be limited to repairing or replacement of any part, provided that such part is returned within thirty (30) days from date of failure to Gearmore through the dealer from whom the purchase was made, transportation charges prepaid.

This warranty shall not be interpreted to render us liable for injury or damages of any kind or nature, direct, consequential or contingent, to person or property. This warranty does not extend to loss of crops, loss because of delay in harvesting or any other expenses, for any other reasons.

Gearmore in no way warrants engines, tires, or other trade accessories, since these items are warranted separately by these respective manufacturers.

Gearmore reserves the right to make improvements in design or changes in specification at any time, without incurring any obligations to owners or units previously sold.

GEARMORE, INC.
13477 Benson Ave.
Chino, CA 91710

Always refer to and heed machine operating warning decals on machine.

The serial number of this product is stored in our computer database, thus submitting a warranty registration card is not required.