



# ROTARY TILLER "S" SERIES

## Operation, Service & Parts Manual



Carefully read this manual  
before using the machine

October 2006

No part of this manual shall be reproduced, copied or disseminated by any means, without manufacturer prior authorization in writing.

Gearmore reserves the right to make any necessary changes without giving prior notice, in order to optimize the quality and safety features and does not commit itself to updating this manual every time a change is made.

This booklet provides a thorough and accurate description of the instruction and maintenance activities to be carried out on the tiller you purchased. We congratulate you on your choice and urge you to thoroughly familiarize yourself with and follow the instructions contained in this manual. This will assure you a long, safe and trouble free working life for your tiller.

**Gearmore shall not assume any responsibility should problems arise as a result of lack of compliance with the instructions and/or operator's negligence.**

The manual is divided in chapters and paragraphs and the pages are numbered, thus offering accurate and precise information.

The requested information can be easily found by searching the key words or referring to the index.

Date of Purchase: \_\_\_\_\_

Model Number: \_\_\_\_\_

Serial Number \_\_\_\_\_

# TABLE OF CONTENTS

## INDEX

### GENERAL INFORMATION

Application . . . . .	Page 1
Symbols . . . . .	Page 1
Safety labels . . . . .	Page 2
Technical data . . . . .	Page 3
Main parts terminology . . . . .	Page 4
Identification plate . . . . .	Page 5
Recommended use . . . . .	Page 5
Inappropriate use . . . . .	Page 5
Torque Specification . . . . .	Page 5

### SAFETY

Safety in the workplace . . . . .	Page 6
User's requirements . . . . .	Page 6
Work clothing . . . . .	Page 6
General safety norms . . . . .	Page 6
Preparation . . . . .	Page 7

### SET UP

Attachment to the tractor . . . . .	Page 8
Quick Hitch Attachment . . . . .	Page 10
PTO shaft connection . . . . .	Page 11
Working depth adjustment . . . . .	Page 12
Leveling board adjustment . . . . .	Page 12
3-Point hitch assembly . . . . .	Page 13

### MAINTENANCE

Road transport . . . . .	Page 14
Shut down . . . . .	Page 14
First check . . . . .	Page 14
Every 8 working hours . . . . .	Page 15
Every 50 working hours . . . . .	Page 15
Every 500 working hours . . . . .	Page 15
Blades replacement . . . . .	Page 16

### SPARE PARTS

How to order spare parts . . . . .	Page 16
Tiller Parts Breakdown . . . . .	Page 17
Tiller Parts List . . . . .	Page 18
Driveline Assembly . . . . .	Page 23
Slip Clutch Assembly . . . . .	Page 24
Limited Warranty . . . . .	Page 25

# GENERAL INFORMATION

## GENERAL INFORMATION

### APPLICATION

The S Series Rotary Tillers are designed to till soil for seedbed or planting preparation. The S Series Tillers are adapted for tractors with 540 rpm PTO speed and Category 2, 3-point hitch tractors up to 90 HP. These tillers are also Quick Hitch adaptable (by means of Quick Hitch Optional Kit).

### SYMBOLS

This booklet contains three "safety pictograms" which highlight the relevant danger levels or important information:



It draws the operator's attention to special situations which may jeopardize people's safety.



It draws the attention to situations which unfavorably affect the machine efficiency, but not people's safety.



It is used for general information, when people's safety or the efficiency of the parts are not at risk.

---

# SAFETY LABELS

## SAFETY LABELS

The safety labels and information on the machine (labels 1, 2 and 3), must be complied with. Failure to comply with these warnings may result in severe injuries or even death. Make sure that the labels are always present and legible; should this not be the case, contact your nearest Gearmore dealer to request replacements

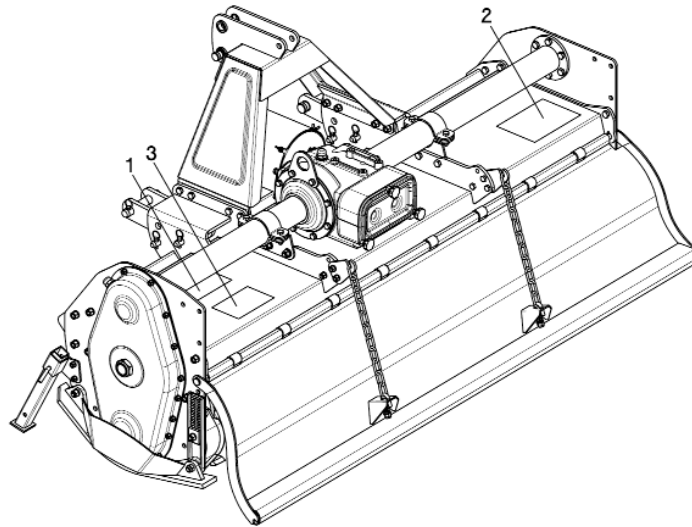

**1**

**DANGER**

1. MAKE SURE DRIVELINES ARE OF THE CORRECT LENGTH AND PROPERLY CONNECTED. DRIVELINE SEPARATION AND/OR PTO STUB SHAFT FAILURE CAN CAUSE INJURY OR DEATH. (See Operator's Manual for procedure)

2. MAKE SURE THAT DRIVELINE SHIELDS ARE INSTALLED CORRECTLY AND TURN FREELY TO AVOID INJURY OR DEATH FROM ENTANGLEMENT

3. MAKE SURE THAT DRIVELINE IS INSTALLED CORRECTLY ON TRACTOR PTO SHAFT. MOVE YOKE BACK AND FORTH UNTIL LOCKING COLLAR CLICKS FORWARD AND LOCKS YOKE IN PLACE.

4. 540 PTO RPM UNLESS SPECIFICALLY MARKED OTHERWISE.

**3**

**WARNING**

SHIELDS AND DEFLECTORS MAINTAINED IN BAD CONDITION MAY CAUSE INJURY OR DEATH FROM ENTANGLEMENT WITH ROTATING PARTS, BEING HIT BY OBJECTS THROWN WITH GREAT FORCE BY BLADES, OR BY BLADE CONTACT.

- Always replace Guards which have been removed for maintenance. Never operate with guard missing or broken.
- Chain Guards, Gearbox, Drivelines Shields, eventual Rubber-fabric Deflectors, and solid band enclosures are subject to wear and lost or broken parts must be replaced or repaired as soon as damage is found.
- Safety shielding must be installed and in good condition to avoid the possibility of thrown objects when the machine is operated in any area where thrown objects could cause injury.

**2**

**DANGER**

FAILING TO FOLLOW SAFETY MESSAGES AND OPERATING INSTRUCTIONS CAN CAUSE SERIOUS BODILY INJURY OR EVEN DEATH TO OPERATOR AND OTHERS IN THE AREA.

1. READ OPERATOR'S MANUAL CAREFULLY AND PAY ATTENTION TO SAFETY DECALS FOR TRACTOR AND TILLER THOROUGHLY TO AVOID MISUSE, ABUSE, AND ACCIDENTS. PRACTICE BEFORE OPERATING.
2. OPERATE ONLY WITH ROPS AND FASTEN SEAT BELT TO AVOID INJURY AND POSSIBLE CRUSHING DEATH FROM OVERTURN. ALLOW NO RIDERS ON TRACTOR OR TILLER. FALLING OFF CAN CAUSE SERIOUS INJURY OR DEATH BY BEING RUN OVER BY TRACTOR OR TILLER OR BY BEING CUT BY THE ROTATING TILLER BLADES. ALLOW NO CHILDREN ON OR NEAR TILLER OR TRACTOR.
3. TO AVOID INJURY FROM FALLING OBJECTS WEAR HARD HAT, SAFETY GLASSES AND SHOES.
4. BLOK UP OR SUPPORT MACHINE SEVERELY BEFORE PUTTING HANDS OR FEET UNDER, OR WORKING UNDERNEATH LIFTED PARTS TO AVOID CRUSHING INJURY OR EVEN DEATH FROM SUDDEN, INADVERTENT DROPPING. MAKING SURE AREA IS CLEAR BEFORE LOWERING.
5. BEFORE TRANSPORTING, PUT LIFT LEVER IN LIFT (DETENT) POSITION AND FOLLOW TRAFFIC CODES. SLOW DOWN AT NIGHT, IN TURNS, & ON HILLSIDES.
6. MAKE SURE THAT SMV SIGN, WARNING LIGHTS, AND REFLECTORS ARE CLEARLY VISIBLE.
7. NEVER OPERATE WITH TILLER RAISED OF GROUND TO REDUCE POSSIBILITY OF INJURY FROM OBJECTS THROWN UNDER TILLER STRUCTURE.
8. BEFORE DISMOUNTING, SECURE TILLER IN TRANSPORT POSITION OR LOWER TO GROUND. STOP PTO, PUT TRACTOR IN PARK OR SET BRAKE, STOP ENGINE, AND REMOVE KEY. NEVER MOUNT OR DISMOUNT MOVING VEHICLE TO PREVENT POSSIBLE CRUSHING INJURY OR DEATH.

1. TRANSPORT SAFELY.
2. USE SMV, LIGHTS, & REFLECTORS.
3. DO NOT OPERATE WITH TILLER RAISED.
4. MOUNTING & DISMOUNTING

# TECHNICAL DATA

## TECHNICAL DATA

Model	Tilling Width		HP	Weight (Approx.)		Working Depth (Max)		Side Drive		Blades (Qty)	Blades	
	cm	Inches		kg	lbs	cm	Inches	Chain	Gear		Blades/ /flange	Shape
S	160	63	60-90	536	1181	20	8		*	36	6	Curved
	180	73	60-90	568	1252	20	8		*	42	6	Curved
	205	83	60-90	612	1350	20	8		*	48	6	Curved
	230	93	60-90	660	1455	20	8		*	54	6	Curved
	255	103	60-90	715	1576	20	8		*	60	6	Curved



**When asking for information or technical service, always specify the machine type and width.**

# MAIN PARTS TERMINOLOGY

## MAIN PARTS TERMINOLOGY

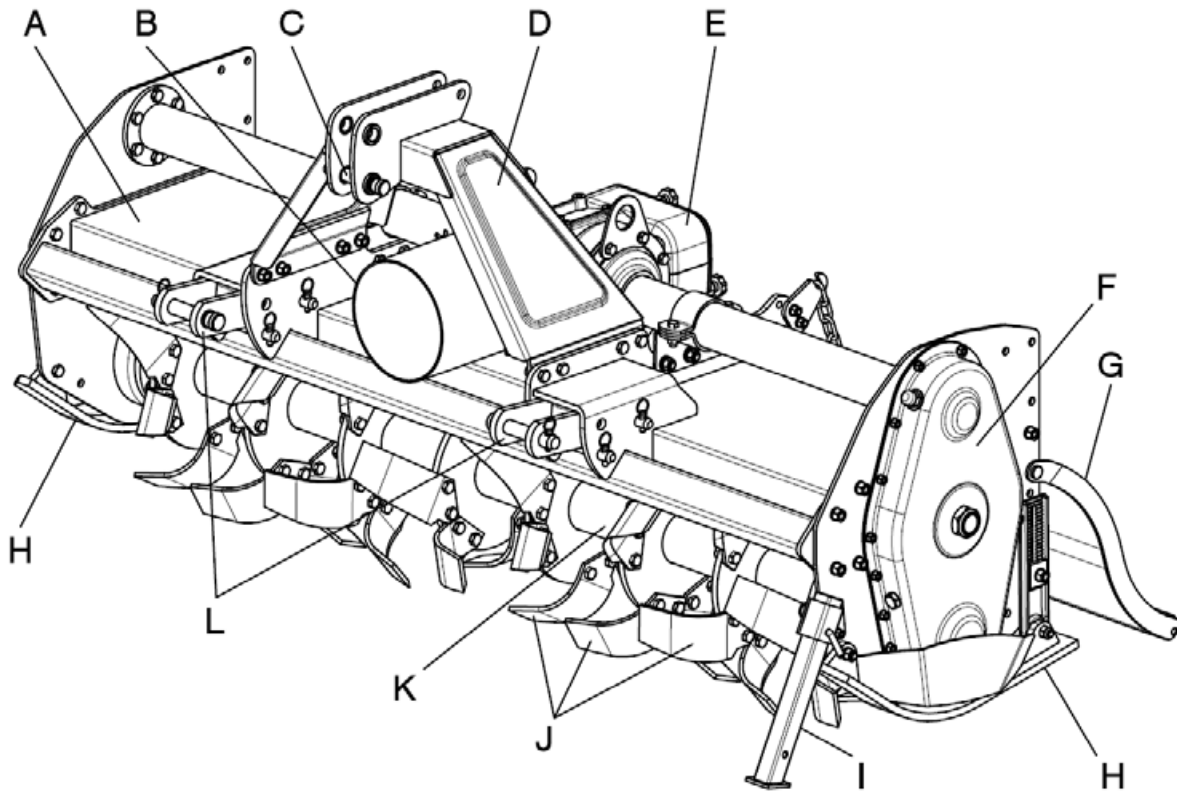

- |    |                   |    |                    |
|----|-------------------|----|--------------------|
| A) | Main Frame        | G) | Rear Board         |
| B) | PTO Guard         | H) | Skid               |
| C) | Top Link Coupling | I) | Parking Stand      |
| D) | Third Point Mast  | J) | Tines              |
| E) | Gearbox           | K) | Rotor              |
| F) | Transmission Case | L) | Lower Hitch Blocks |

# INFORMATION

## IDENTIFICATION PLATE

An identification plate is placed on each tiller and is structured as follows:

Serial number (sample):



## RECOMMENDED USE

The tillers described in this instruction and maintenance manual, have been designed explicitly to till the land. Any other use jeopardizes the operator's safety and the machine integrity.

## INAPPROPRIATE USE

The tillers shall not be used as follows:

- Connected to vehicles which do not have a suitable power or weight.
- Without being properly installed by securing the hitch brackets to all three points of the tractor lift unit.
- Tilling of extremely stony or unsuitable ground.
- Raising or lifting of the equipment when the power take off is engaged.
- In close proximity to person/s when power is engaged.
- Do not stand or step on the equipment when it is being operated or transported.
- Do not operate the machinery while wearing unsuitable (loose fitting) clothing.

## TORQUE SPECIFICATIONS

For correct hardware tightening on the tiller, we suggest the use of suitable torque wrench and the applicable torque as listed in the table below:

M-THREADED SCREW/BOLTS  
Bolt grade

Thread	8.8		10.9	
	Nm	Lb-ft	Nm	Lb-ft
M6	11	8.5	17	12
M8	28	20	40	30
M10	55	40	80	60
M12	95	70	140	105
M14	150	110	225	165
M16	240	175	305	225
M18	330	250	475	350



# SAFETY

## SAFETY IN THE WORKPLACE

Most of the accidents, which occur while the operator is using the machine or the equipment or carrying out maintenance and repair activities, are caused by the non-compliance with the main safety requirements.

Therefore the potential risks must be fully understood and special attention must be paid to the activity which is being executed.

**If potentially dangerous situations are known,  
accidents can be prevented!**

## USER'S REQUIREMENTS

The equipment user must have the following:

**Physical:** good sight, co-ordination and capability to execute all instructions in a safe manner.

**Mental:** the users must understand and follow the prescribed norms, rules and safety measures. They must be careful, pay attention to their own safety and the safety of other people and act properly and in a responsible way.

**Training:** the users must read and understand this manual, its pictures and charts, and the identification and hazard plates. They must be specialized, trained and qualified on any use and maintenance activities.

## WORK CLOTHING

The following clothing and personal protective equipment must be used when working and executing maintenance and repair activities:

- Overalls or any other comfortable outfit; make sure that they are not too loose since they might be caught by moving parts.
- Protective gloves.
- Goggles or mask to protect the eyes and face.
- Safety helmet.
- Safety shoes.



**Make sure that the personal protective equipment is properly stored and complies with the laws in force.**

## GENERAL SAFETY NORMS

The features of the area where work is taking place must always be taken into consideration:

- Do not stand in the working radius of the operating machinery or any other machine accessories when the equipment is running.

# PREPARATION

## Prepare the work:

- Do not drink alcohol, take drugs, or any other substances which may affect your ability to use the equipment before or when working.
- Make sure that there is sufficient fuel in the tractor to prevent the machine from stopping during work.
- Do not use the equipment under unsafe conditions, e.g. do not make temporary repairs just to start or keep working; do not work at night if the area is not well illuminated.

## When working or executing maintenance activities, remember:

- The labels and stickers providing instructions on the use of the equipment or information on dangers must not be removed or hidden, and must be legible.
- Do not remove the safety devices, covers and safety guards, unless maintenance activities are being carried out. If the safety devices must be removed, turn the engine off, remove them correctly and re-install them before turning the tractor on.
- Do not lubricate, clean or adjust moving parts.
- Use the appropriate tools to execute maintenance or adjustment activities on the equipment.
- Do not use damaged or unsuitable tools, e.g. pliers rather than wrenches etc.
- Prior to carrying out activities on hydraulic lines under pressure, or disconnecting their components, make sure that the line is no longer under pressure and that it does not contain any hot fluids.
- Check all the fittings and make sure that they are well connected before supplying pressure to the hydraulic lines.
- Make sure that no tools, clothes or any other materials are left in areas where moving parts are present when the maintenance and repair activities are completed.
- Do not give directions and make signals at the same time during a maneuver. Maneuver directions and signals must be given from one person only.
- Do not unexpectedly call an operator, if not necessary. Do not startle the operator, e.g. by throwing objects.
- Pay attention to people in the vicinity of the work area, especially children!
- Make sure that nobody is standing in the working range of the equipment.
- Do not use the equipment to lift people.
- When the equipment is not needed, turn the engine off, leave the vehicle on a flat surface, with the first gear and the parking brake engaged. Disengage the power take off.
- Do not execute any cleaning, lubrication, repair or adjustments when the engine is running and the equipment is in the raised position.
- Do not work on steep slopes, if the stability of the vehicle can be jeopardized.

**Manufacturer shall not assume any responsibilities if these instructions are not strictly followed.**

# SET-UP

## ATTACHMENT TO THE TRACTOR

This tiller may be attached to any tractor equipped with a Cat. 2, 3-point hitch with suitable ball ends; it can also be attached by means of a Cat. 2 Quick Hitch.

### 3-POINT CATEGORY 2 HITCH

To connect the tiller to the tractor's Cat. 2, 3-point hitch, do the following operations:

- 1) Put the floating brackets in the lower position inserting the pin A in the upper hole as shown in picture 1; this gives you the standard A.S.A.E. vertical dimension of 20" (picture 2). The horizontal distance between the brackets is 32 1/2".

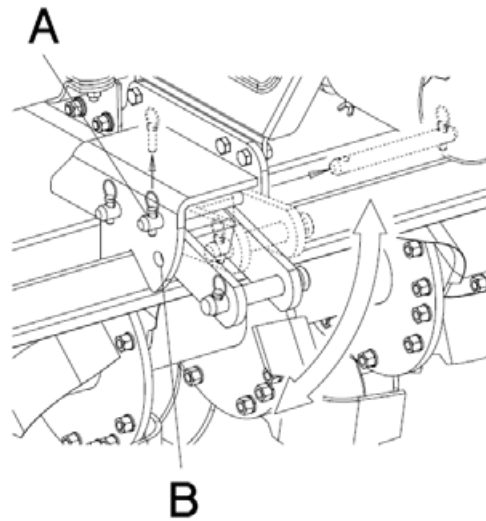

picture 1

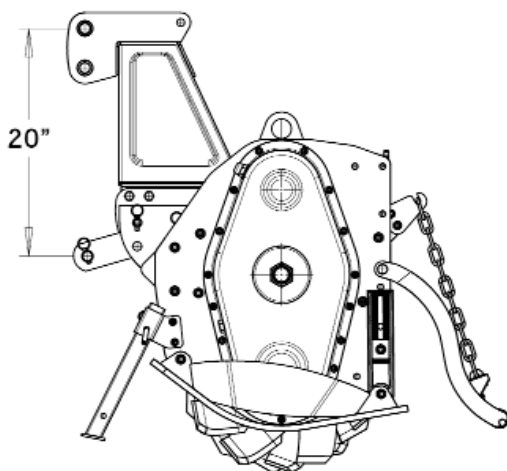

picture 2

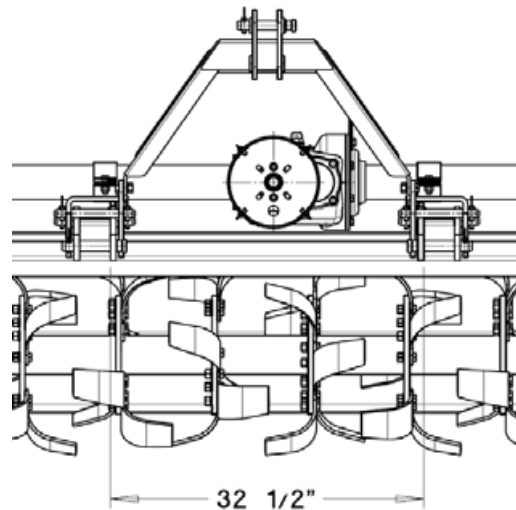

# SET-UP

- 2) Remove the cotter pins from the hitch pins (picture 3);
- 3) Remove the lower hitch pins from the lower hitch blocks (picture 3);

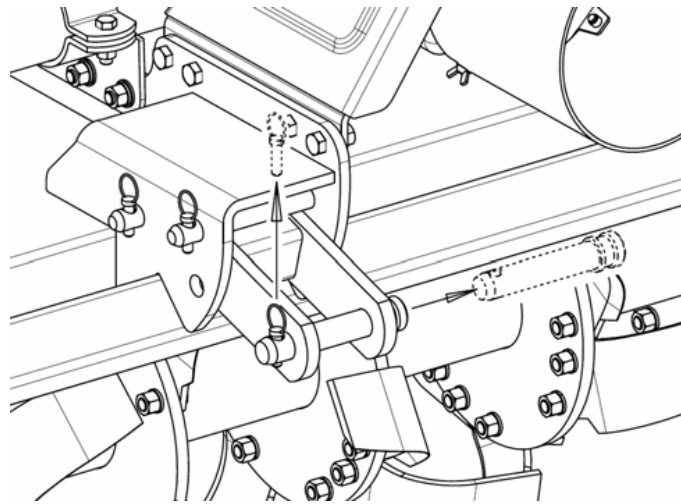

picture 3

- 4) Before attaching the equipment to the tractor, make sure that the ground is smooth and flat and that nobody is standing between the tractor and the tiller; slowly move the tractor towards the tiller by aligning the tractor lifter arms with the blocks' holes (picture 4); turn the engine off and pull the brake;

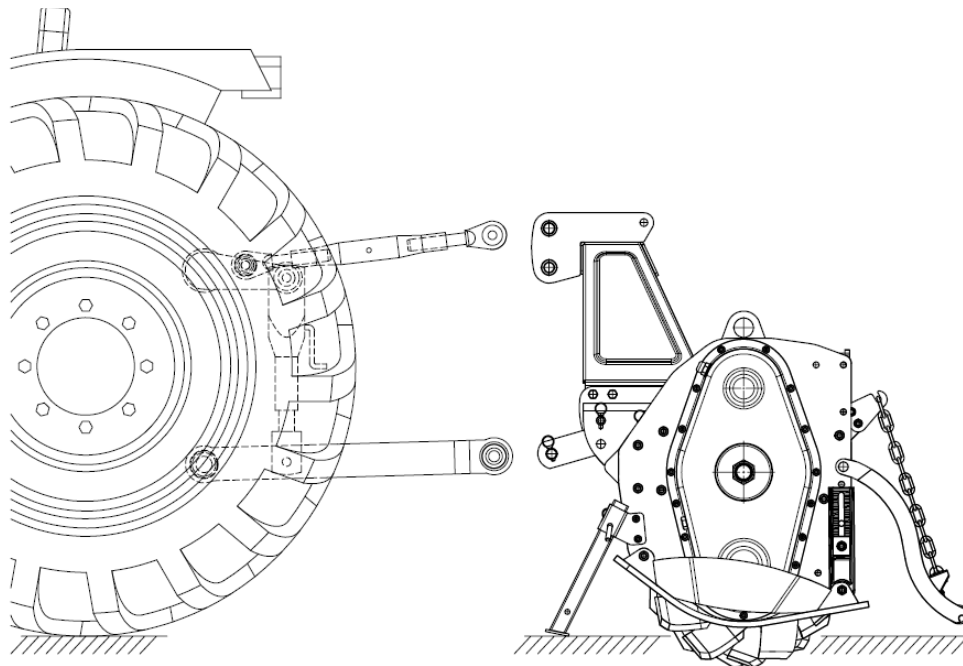

picture 4

# SET-UP

5) Insert the lower hitch pins through the hitch blocks and ball ends (picture 5);

6) Secure them by means of the cotter pins which were previously removed (picture 5);

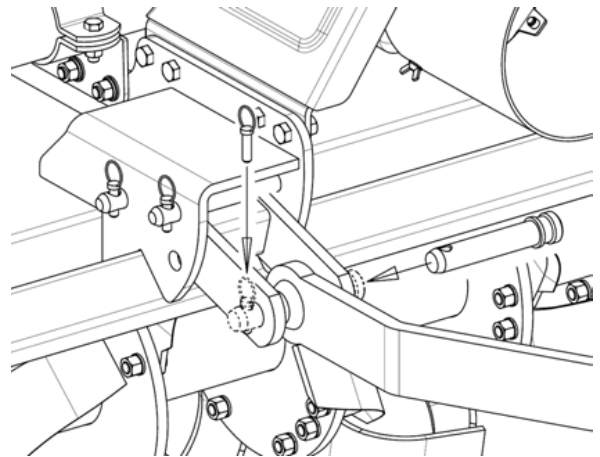

picture 5

7) Connect the tractor top link to the third upper point by removing the pin located between the two plates, inserting the top link and securing it by means of the cotter pin. Shift the parking stand in the upper position .

8) Adjust the top link so that the upper part of the frame is parallel to the ground. Block all the linking parts by means of the sway chains or arms.

9) Make sure that the central unit axis (case/bevel gear pair) is parallel to the ground, thus minimizing the stresses on the power take off and increasing the working life of the equipment.



**After executing all the above mentioned activities, make sure that all the nuts and bolts are tightened.**

## 3-POINT CATEGORY 2 QUICK HITCH

The S Series Reverse Tillers are Cat. 2 Quick Hitch adaptable. To attach the implement to the tractor it is necessary to order the Quick Hitch Kit composed of 3 bushings. The following operations are needed:

1) Put the floating brackets in the upper position inserting the pin in the lower hole as shown in picture 7; this gives you the standard A.S.A.E. vertical dimension of 15" (picture 6).

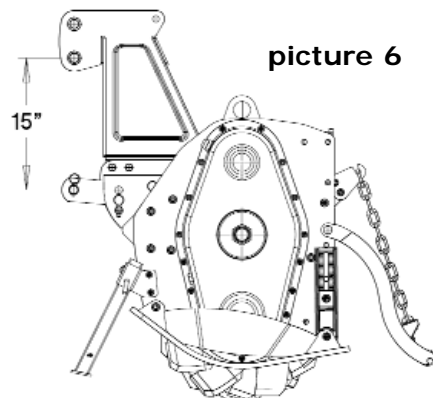

picture 6

# SET-UP

2) Remove the cotter pin from the hitch pins and lower hitch pins from the lower hitch blocks (picture 3).

3) Insert the lower bushing of the kit in the lower hitches (picture 7);

4) Insert the lower hitch pins through the hitch block and bushing (picture 7);

5) Secure it by means of the cotter pins which were previously removed (picture 7);

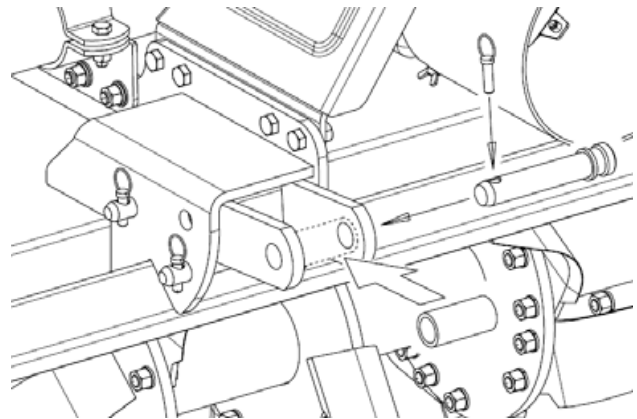

picture 7

6) Repeat the same operations from 2 to 5 for the upper bracket with the upper bushing.

7) Before attaching the equipment to the tractor, make sure that the ground is smooth and flat and that nobody is standing between the tractor and the tiller; slowly move the tractor towards the tiller by aligning the tractor lifter arms with the bracket holes; turn the engine off and pull the brake.

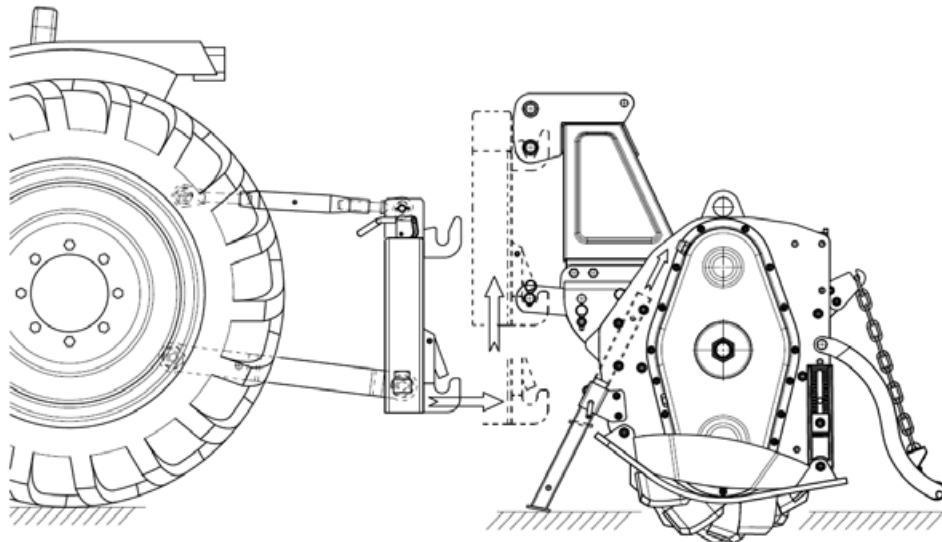

8) Lift the Quick Hitch until its hooks engage the hitches of the implement.

9) Raise the parking stand to the upper position.

# SET-UP

## PTO SHAFT CONNECTION

Before installing the PTO shaft make sure that the RPM rating and the direction of rotation match those of the tractor. Carefully read the PTO shaft and tractor instructions. Furthermore, accurately read the instructions of the manufacturer of the PTO shaft and of the tractor.

Before starting any activity, make sure that the guards are installed on the power take off of the tractor and PTO shaft. Make sure that they cover the PTO shaft throughout its length.



**Caution**

**When fully extended, the plastic pipes must overlap by at least 1/3 of the length of the pipes (LT). When retracted, the minimum acceptable clearance is 2" (picture 8).**

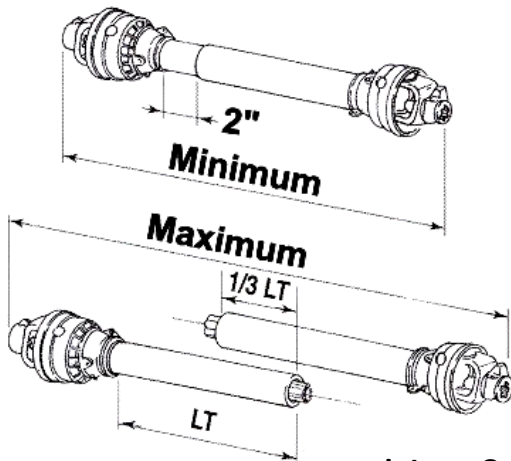

picture 8

Check that the PTO shaft minimum and maximum length are within the parameters of the machine tractor coupling.

Should problems arise, contact your dealer. After the installation, anchor the PTO shield to the tractor and machine using the special chains; make sure that it turns smoothly. If the PTO shaft is equipped with safety devices, e.g. torque limiters or free-wheel devices, install them on the operative machine side. For the use and maintenance of the PTO shaft, please refer to the relevant manual.

## SPEED GEAR SETUP

The Series S gearbox is provided with two pair of gears. By changing their relative position 4 different rotor speeds are achieved. Choose the desired rotor speed and follow the instructions below:

- 1) Drain the oil from the gearbox;
- 2) Remove the cover A unscrewing the lobe knobs B (see picture 9).

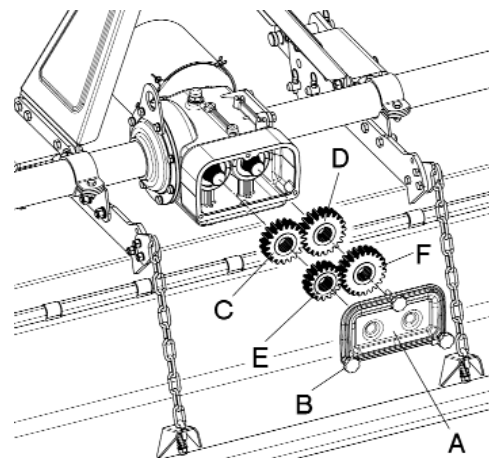

picture 9

# SET-UP

- 3) Change the position of the gears C and D according to the following table:

	C GEAR	D GEAR	ROTOR SPEED
1	23 teeth	17 teeth	145 rpm
2	21 teeth	19 teeth	175 rpm
3	19 teeth	21 teeth	215 rpm
4	17 teeth	23 teeth	260 rpm

- 4) Fix the remaining gears E and F on the suitable pins on the internal face of the cover;  
 5) Put back the cover in its position, tighten the screws, and fill with oil.

## WORKING DEPTH ADJUSTMENT

The working depth of the equipment depends on the position of the lateral skids. If the skids are raised, the working depth increases; if the skids are lowered, the working depth decreases.

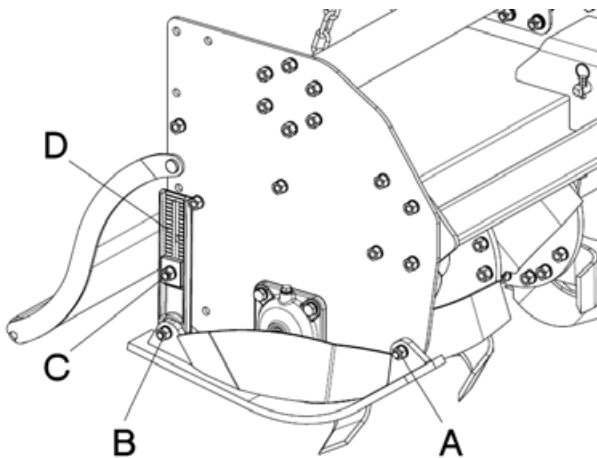

picture 10

To adjust the working depth, loosen nut **A**, **B**, and **C** (picture 10) and adjust the skid height according to the notches **D**.

When the adjustment is completed, tighten the screws to the correct torque, according to the values suggest in **Torque Specifications**, page 8.

**IMPORTANT:** Make sure that the skids are set at the same height on both sides.

## LEVELING BOARD ADJUSTMENT

The rear leveling board can be adjusted in height to better compact the ground and make it flat. The adjustment can be made by releasing chains **A** (picture 11) from upper hooks **B** and inserting them back to the desired height.

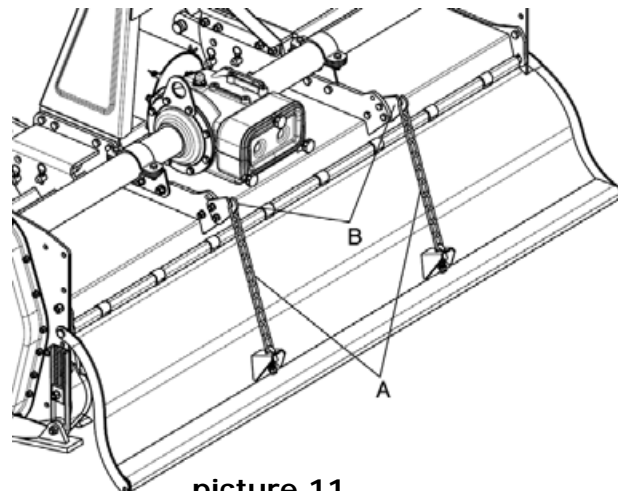

picture 11



# MAINTENANCE



These activities must be carried out with the engine off, the power take off disengaged and the hand brake applied. If needed, lift the equipment and place it on supports, thus preventing any injuries that might be caused by a sudden fall of the equipment.

## START UP

After carrying out these adjustments, the equipment is ready for use. When at the working area, do not start the power take off with the tiller in working position in the ground. Be sure to lift it by a few centimeters using the tractor lift. Start the engine, engage the power take off, lower the equipment to its working position and start.

## ROAD TRANSPORT

With reference to road transport, follow local traffic regulations.

## SHUT DOWN

The following activities are recommended if the tiller will not be used for a long period of time:

1. Clean and dry the equipment.
2. Inspect the equipment and replace the damaged or worn parts if necessary.
3. Tighten all the screws and nuts.

Lubricate and cover the machine with a tarpaulin and store it in a dry place.

## MAINTENANCE

Maintenance is crucial for the working life and efficiency of any agricultural equipment. If the equipment is properly maintained and operated, a long working life and operator safety are assured.

The maintenance intervals indicated in this booklet are provided as a mere reference and are related to normal working conditions; changes may occur depending on the type of activities, environmental dust, seasonal factors, etc.



- Before injecting lubricating grease into the grease fittings, clean the fittings to prevent mud, dust, or any other foreign matter from contaminating the grease and reducing the lubrication effect.
- When adding or changing the oil, use the same type of oil to prevent mixing oils with different features.
- All maintenance activities must be carried out with the tiller resting horizontally on the ground.
- After using the equipment for a few hours, make sure that all the bolts (especially tine bolts) are tightened; regularly check all the machine guards.

## FIRST CHECK

- After 50 working hours, change the oil in the gearbox and make sure that all the screws and bolts are tightened.

# MAINTENANCE

## EVERY 8 WORKING HOURS

- Grease the PTO shaft crosses.

## EVERY 50 WORKING HOURS

- Check the oil level in the external rotor bearing through the inspection plug **B**. If needed remove the plug **A** and add SAE EP 80W90 oil (picture 12).
- Check the oil level in the case/bevel gear pair by removing gearbox's upper oil plug (**A** - picture 13); oil level should be contained between the 2 nicks of MIN & MAX of the dip stick oil plug (**B** - picture 13). If needed add SAE EP 80W90 oil.
- Check the oil level in the side transmission (**A** - picture 14). If needed add SAE EP 80W90 oil.
- Make sure that all the screws and bolts, especially on the blades, are tightened.

## EVERY 500 WORKING HOURS

- Change the oil of the case/bevel gear pair, side transmission and rotor support; use SAE EP 80W90 oil. Contact the closest dealer for this maintenance activity.

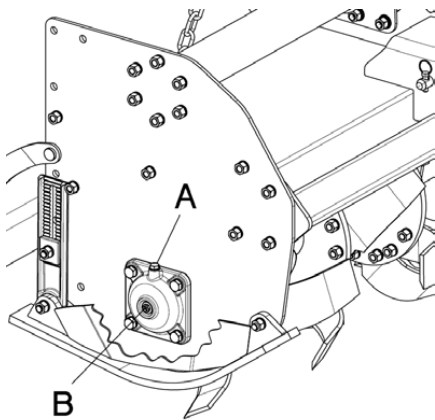

picture 12

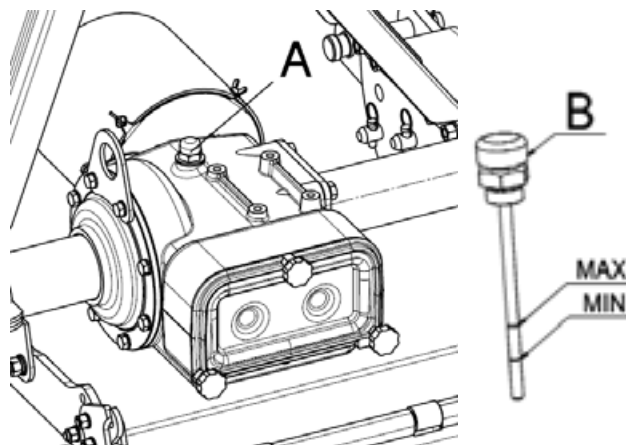

picture 13

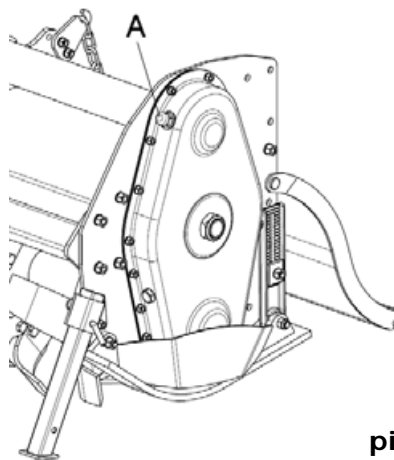

picture 14



The old oil must be disposed of in compliance with the local laws where these activities are carried out; do not spill or dispose of waste oil on the ground.

# SPARE PARTS



The maintenance activities must be carried out with the engine off, the power take off disengaged, the parking brake engaged, and the equipment placed on the ground.

## BLADES REPLACEMENT

To assure the optimum efficiency of the machine, make sure that the tiller blades are in a good working condition and that their bolts are tightened; replace them if they are broken or bent. The new parts must be installed in the original position.



Before replacing the blades, turn the tractor engine off, pull the parking brake, disengage the power take off, raise the tiller using the tractor lift, and install supports to prevent accidental dropping of the machine.

Pay special attention to the bolts **A** on the blades (picture 15): the screw head must be placed on the blade side, with the washer and the nut on the flange side, so that the bolts cannot loosen while the equipment is being used.

When several blades must be replaced, replace one blade at a time, so that the initial helical layout is maintained (picture 15).

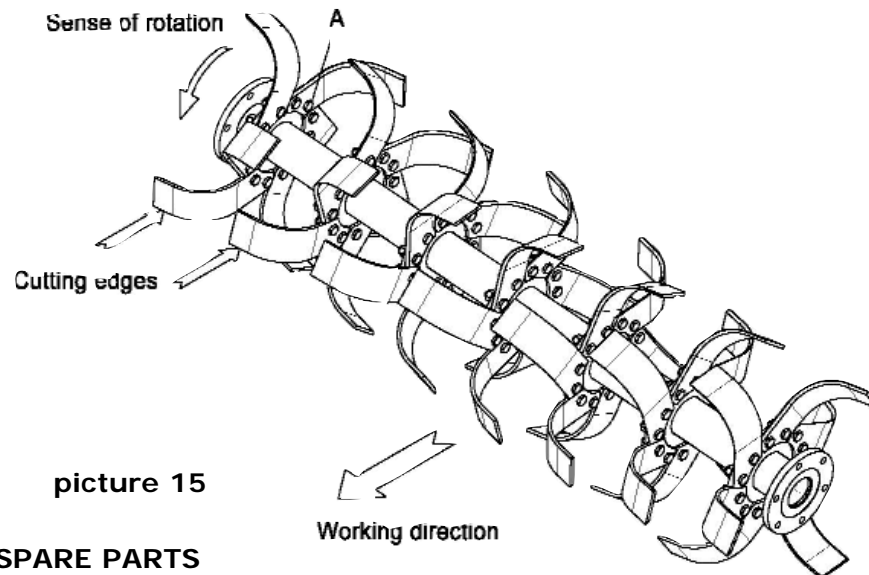

## HOW TO ORDER SPARE PARTS

For spare parts requests please refer to our spare parts catalog.

The spare parts can be ordered from the dealer or service center. The following data must always be specified:

- Equipment type and width.
- Part number of the requested component. If the code number is missing, indicate the table number in which it is shown and the relevant reference.
- Description of the part and requested quantity.
- Requested type of transport. Should this information not be provided, the dealer or service center shall not be responsible for delays caused by circumstances beyond their control. The addressee shall be responsible for any transport charges.

# "S" TILLER ASSEMBLY

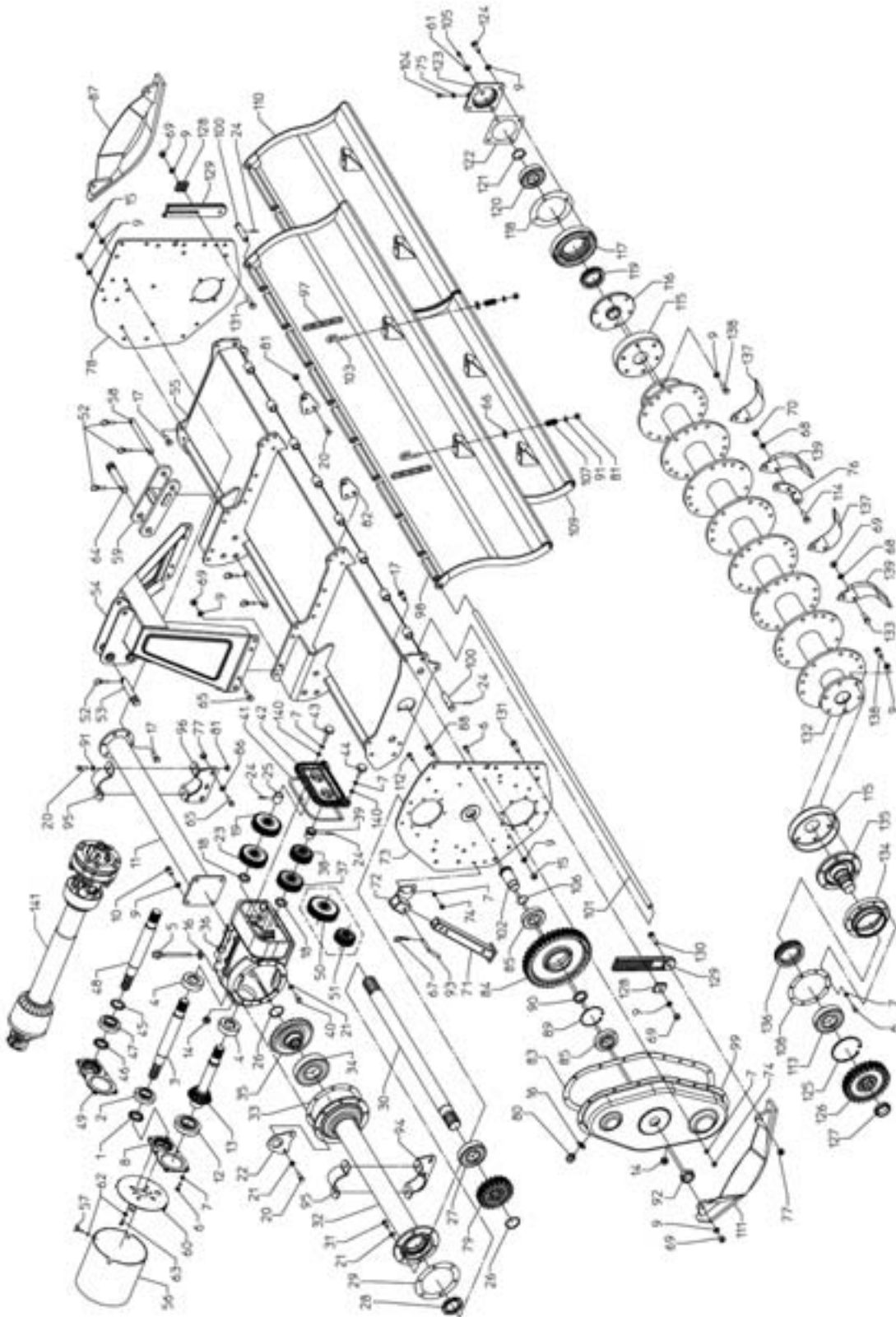

# TILLER ASSEMBLY

<u>REF#</u>	<u>QTY.</u>	<u>PART NO.</u>	<u>DESCRIPTION</u>
1	1	40x62x10	Oil Seal 40 x 62 x 10 S160 through S230
2	1	30308	Bearing S160 through S230
3	1	4224252	PTO Shaft S160 through S230
4	2	32308	Bearing 32308
5	1	3443022	Plug M22 x 1.5
6	14	31510025	Bolt M10 x 1.5 x 25 UNI 5739
7	36	34121010	Washer 10 UNI 1751
8	1	4644260	Holder Oil Seal Cover S160 through S230
9	40	34121014	Washer 14 UNI 1751
10	4	31514030	Bolt M14 x 2 x 30 UNI 5739
11	1	4004360	External Support S160
11	1	4004361	External Support S180
11	1	4004362	External Support S205
11	1	4004363	External Support S230
11	1	4004364	External Support S255
12	1	30310	Bearing 30310
13	1	4724251	Bevel Pinion Z=14
14	2	3441022	Oil Plug M22 x 1.5
15	19	34101014	Nut M14 x 1.5 UNI 5587
16	2	6470118	Washer
17	19	31614035	Bolt M14 x 1.5 x 35 UNI 5740
18	2	4593264	Spacer 40 x 48 x 10
19	1	4224257	Gear Z=23
20	As Req'd*	31512035	Bolt M12 x 1.75 x 35 UNI 5739
21	14	34121012	Washer 12 UNI 1751
22	1	4934657	Lifting Hook
23	1	4224256	Gear Z=21
24	4	6330635	Split Pin 6 x 35
25	1	4534263	Gear Guide Pipe
26	2	47155	Circlip E 55
27	1	2006311	Bearing 6311
28	1	55x90x10	Oil Seal 55 x 90 x10
29	1	4784734	Gasket
30	1	4214530	Shaft S160
30	1	4214531	Shaft S180
30	1	4214532	Shaft S205
30	1	4214533	Shaft S230
30	1	4214534	Shaft S255
31	6	31512025	Bolt M12 x 1.75 x 25 UNI 5739
32	1	4004741	Drive Side Support S160
32	1	4004742	Drive Side Support S180

# TILLER ASSEMBLY

<u>REF#</u>	<u>QTY.</u>	<u>PART NO.</u>	<u>DESCRIPTION</u>
32	1	4004743	Drive Side Support S205
32	1	4004744	Drive Side Support S230
32	1	4004745	Drive Side Support S255
33	1	4784825	Gasket
34	1	6314	Bearing 6314
35	1	4724833	Ring Bevel Gear Z=29
36	1	4654250	Gearbox
37	1	4224255	Gear Z=19
38	1	4224254	Gear Z=17
39	1	4534262	Gear Guide Pipe
40	8	31512030	Bolt M12 x 1.75 x 30 UNI 5739
41	1	4784264	Gasket
42	1	4674261	Cover
43	1	6601055	Knob M10 x 55
44	2	6601035	Knob M10 x 35
45	1	4594216	Spacer S255 50 x 60 x 10
46	1	45x62x10	Oil Seal 45 x 62 x 10 S255
47	1	32210	Bearing 32210 S255
48	1	4224259	Shaft S230/S255 1-3/4 6 Spline
49	1	4644261	Cover S255
50	1	4224258	Gear Z=25 Optional 1000 RPM
51	1	4224253	Gear Z=15 Optional 1000 RPM
52	11	6350010	Lynch Pin D10
53	1	5304435	Pin
54	1	4004297	Junction for 3rd Point
55	1	4104270	Frame S160 (gear drive)
55	1	4104271	Frame S180 (gear drive)
55	1	4104272	Frame S205 (gear drive)
55	1	4104273	Frame S230 (gear drive)
55	1	4104274	Frame S255 (gear drive)
56	1	6654241	Protecting Cover
57	3	33108020	Bolt M8 x 1.25 x 20 UNI 5449
58	4	4304202	Pin
59	2	4004298	Plate 3rd Point
60	1	4934240	Guard Support
61	1	6470114	Washer
62	5	34118008	Washer UNI 6593
63	2	31508016	Bolt M8 x 1.25 x 16 UNI 5739
64	1	5304434	Lower 3rd Point Hitch Pin
65	12	31614040	Bolt M14 x 1.5 x 40 UNI 5740
66	As Req'd*	34118012	Washer M12

# TILLER ASSEMBLY

<u>REF#</u>	<u>QTY.</u>	<u>PART NO.</u>	<u>DESCRIPTION</u>
67	1	6351006	Split Pin 3 x 60
68	As Req'd*	34132014	Washer FIAT 10188
69	As Req'd*	34101014	Nut M14 UNI 5587
70	As Req'd*	34101914	Nut M14 UNI 5587
71	1	4002376	Park Stand
72	1	4002377	Park Stand Support
73	1	4004294	Gearing Side Plate
74	19	34100010	Nut M10 UNI 5587
75	1	6470112	Washer
76	As Req'd*	4934019	Counterflanges For Blades (Optional)
77	6	34107014	Stop Nut M14
78	1	4934223	External Side Plate
79	1	4724886	Driving Gear Z=20
80	1	3442022	Plug M22 x 1.5
81	As Req'd*	34106012	Self Locking Nut M12
82	As Req'd*	4934778	Chain Plate
83	1	4784922	Gasket
84	1	4724887	Intermediate Gear Z=41
85	2	30309	Bearing 30309
86	4	34120014	Washer 14
87	1	4004431	Right Skid
88	2	31414045	Bolt Bolt M14 x 1.5 x 45 Length 20
89	1	472110	Circlip I110 Internal
90	1	4594936	Spacer 45 x 60 x 8.3
91	As Req'd*	34120012	Washer 12 UNI 6592
92	1	34106040	Self Locking Nut M40
93	1	4236115	Pin, Park Stand Locking
94	1	4004529	Support, Extension Clamping (LH)
95	2	4834518	U Bolt
96	1	4004530	Support, Extension Clamping (RH)
97	As Req'd*	4508001	Chain
98	1	4004280	Bonnet S160
98	1	4004281	Bonnet S180
98	1	4004282	Bonnet S205
99	1	4014883	Cover
100	2	4232111	Cover Side Pin
101	1	4232106	Bonnet Pin S160
101	1	4232107	Bonnet Pin S180
101	1	4232108	Bonnet Pin S205
101	1	4232109	Bonnet Pin S230
101	1	4232110	Bonnet Pin S255

# TILLER ASSEMBLY

<u>REF#</u>	<u>QTY.</u>	<u>PART NO.</u>	<u>DESCRIPTION</u>
102	1	4204921	Pin
103	As Req'd*	4302183	Chain Hook
104	1	31510010	Bolt M10 x 1.5 x 10 UNI 5739
105	1	3444014	Oil Level Plug
106	1	6800129	Gasket
107	As Req'd*	4212214	Spring
108	1	4784635	Gasket
109	1	4004289	Left Bonnet S230
109	1	4004290	Left Bonnet S255
110	1	4004287	Right Bonnet S230
110	1	4004288	Right Bonnet S255
111	1	4004430	Left Skid
112	2	31510030	Bolt M10 x 1.5 x 30 UNI 5739
113	1	6312	Bearing 6312
114	As Req'd*	31414950	Bolt M14 x 1.5 x 50 Length 20
115	2	4144201	Dust Cover
116	1	4704006	Hub Right Side
117	1	4644005	Bearing Support
118	1	4784117	Hub Gasket Right Side
119	1	6203911	Oil Seal GNL 6460 74 x 94 x 20
120	1	6310	Bearing 6310
121	1	47150	Circlip E50
122	1	4784118	Gasket
123	1	4644001	Cover Right Side
124	4	31514045	Bolt M14 x 2 x 45 UNI 5739
125	1	472130	Circlip I 130
126	1	4724888	Gear Z=27
127	1	34127055	Self Locking Metal Ring M50 x 1.5
128	2	4704654	Plate, Rod Adjustment
129	2	4704653	Skid Adjusting Rod
130	2	31414055	Bolt M14 x 1.5 x 55 UNI 5738
131	2	31414050	Bolt M14 x 1.5 x 50 UNI 5738
132	1	4004370	Rotor S160
132	1	4004371	Rotor S180
132	1	4004372	Rotor S205
132	1	4004373	Rotor S230
132	1	4004374	Rotor S255
133	As Req'd*	31414040	Bolt M14 x 1.5 x 40 Length 20
134	1	4704009	Pipeline Gear Support
135	1	4724008	Pipe Gear Support Hub



# TILLER ASSEMBLY

<u>REF#</u>	<u>QTY.</u>	<u>PART NO.</u>	<u>DESCRIPTION</u>
136	1	6200750	Oil Seal 92 x 113 x 24
137	As Req'd*	4814519	Right Blade
138	12	31514035	Bolt M14 x 2 x 35 UNI 5739
139	As Req'd*	4814518	Left Blade
140	3	34120010	Washer
141	1	EYE81064-2254	Driveline S160, S180, S205, & S230
141	1	EYE81074-2255	Driveline S255

**\* Quantities Required**

REF. #	QUANTITIES FOR MODEL NUMBER				
	S160	S180	S205	S230	S255
20	10	10	10	14	14
66	2	2	2	4	4
68	72	84	96	108	120
69	84	96	108	120	132
70	72	84	96	108	120
76	18	21	24	27	30
81	10	10	10	16	16
82	2	2	2	4	4
91	6	6	6	8	8
97	2	2	2	4	4
103	2	2	2	4	4
107	2	2	2	4	4
114	72	84	96	108	120
133	72	84	96	108	120
137	18	21	24	27	30
139	18	21	24	27	30

# DRIVESHAFT ASSEMBLY

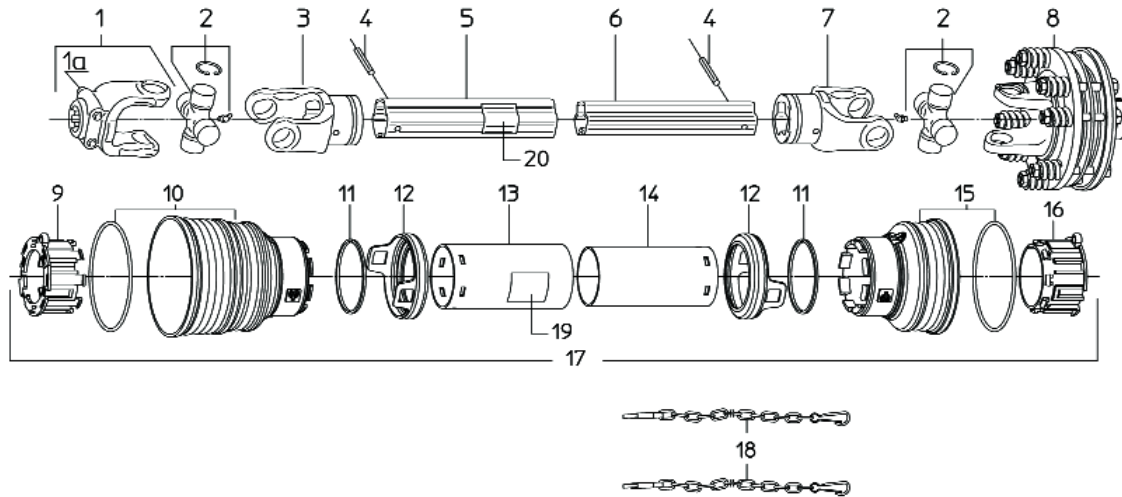

<b>REF#</b>	<b>QTY.</b>	<b>PART NO.</b>	<b>DESCRIPTION</b>
1	1	1028010	Yoke Assembly
1A	2	1581038	Push Pin Kit
2	2	1008020	Cross Assembly
3	1	1708067	Outer Tube Yoke
4	2	6331090	10 x 90 Elastic Pin
5	1	1818045	Outer Tube S160, S180, S205 & S230
5	1	1818055	Outer Tube S255
6	1	1817045	Inner Tube S160, S180, S205 & S230
6	1	1817055	Inner Tube S255
7	1	1708069	Inner Tube Yoke
8	1	1468031	Torque Limiter S160, S180, S205 & S230
8	1	1448032	Torque Limiter S255
9	1	1788010	Tube Bearing Outer Tube
10	1	1788003	Standard Cone
11	2	1218035	Stop Ring
12	2	1888009	Safety Coupling
13	1	1778034	Outer Tube Shield S160, S180, S205 & S230
13	1	1778044	Outer Tube Shield S255
14	1	1879034	Inner Tube Shield S160, S180, S205 & S230
14	1	1879044	Inner Tube Shield S255
15	1	1788002	Short Cone
16	1	1788011	Tube Bearing Inner Tube
17	1	90SS8034	Complete Protection S160, S180, S205 & S230
17	1	90SS8044	Complete Protection S255
18	2	1006065	Anti-Rotation Chain
19	1	1140010	Outer Decal
20	1	1140011	Inner Decal

# SLIP CLUTCH ASSEMBLY

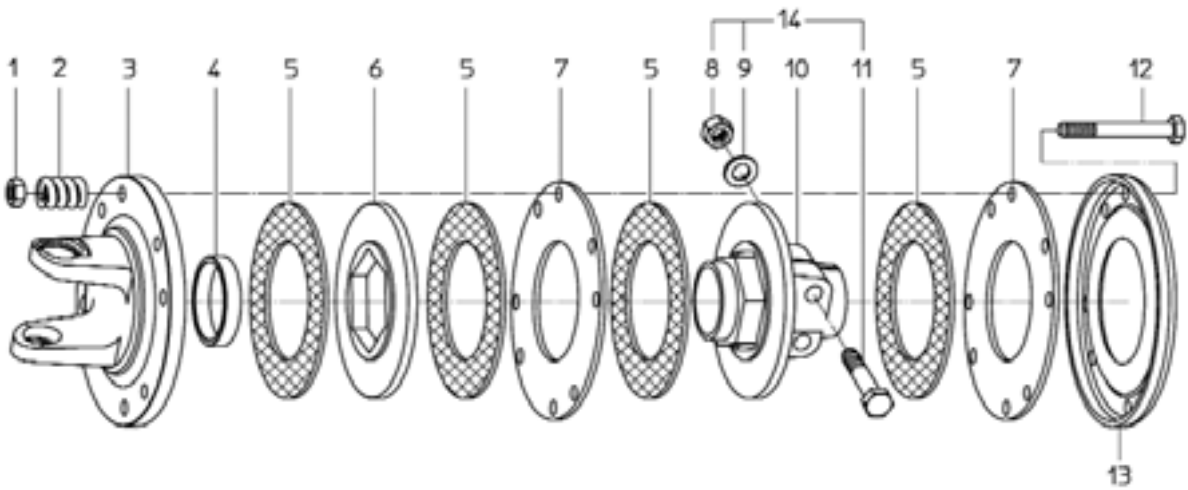

<u>REF#</u>	<u>QTY.</u>	<u>PART NO.</u>	<u>DESCRIPTION</u>
1	8	6411010	Lock Nut
2	8	1215012	Spring
3	1	1708006	Flange With Yoke
4	1	1705009	Bushing
5	4	1808010	Friction Disc
6	1	1708034	Middle Plate Hex
7	2	1138008	Inner Plate Round
8	2	6410112	Screw Nut S160, S180, S205 & S230
8	2	6410114	Screw Nut S255
9	2	6412112	Spring Washer S160, S180, S205 & S230
9	2	6412114	Spring Washer S255
10	1	1708018	Hub With Flange S160, S180, S205 & S230
10	1	1708019	Hub With Flange S255
11	2	6141270	Bolt S160, S180, S205 & S230
11	2	6141480	Bolt S255
12	8	6001010	Bolt For Spring
13	1	1138007	Cover Plate
14	2	6761270	Locking Bolt Kit S160, S180, S205 & S230
14	2	6761480	Locking Bolt Kit S255

# LIMITED WARRANTY



GEARMORE, INC., warrants each new Gearmore product to be free from defects in material and workmanship for a period of twelve (12) months from date of purchase to the original purchaser. This warranty shall not apply to implements or parts that have been subject to misuse, negligence, accident, or that have been altered in any way.

Our obligation shall be limited to repairing or replacement of any part, provided that such part is returned within thirty (30) days from date of failure to Gearmore through the dealer from whom the purchase was made, transportation charges prepaid.

This warranty shall not be interpreted to render us liable for injury or damages of any kind or nature, direct, consequential or contingent, to person or property. This warranty does not extend to loss of crops, loss because of delay in harvesting or any other expenses, for any other reasons.

Gearmore in no way warrants engines, tires, or other trade accessories, since these items are warranted separately by these respective manufacturers.

Gearmore reserves the right to make improvements in design or changes in specification at any time, without incurring any obligations to owners or units previously sold.

GEARMORE, INC.  
13477 Benson Ave.  
Chino, CA 91710

Always refer to and heed machine operating warning decals on machine.

*The serial number of this product is stored in our computer database, thus submitting a warranty registration card is not required.*