

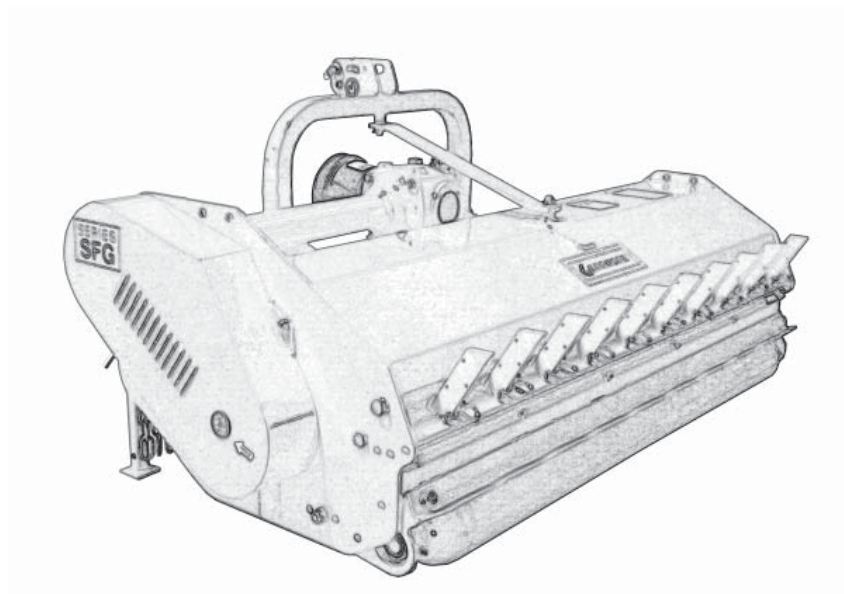

MOWER/SHREDDERS



**Operation, Service,
& Parts Manual For
Models SFG95, 125,
140, 155, 185, & 200
Starting from s/n 1389**

May 2012 Rev. March 2013

TABLE OF CONTENTS

SECTION	DESCRIPTION	PAGE
1	General Information	1
1.1	Introduction.....	1
1.2	Symbols	1
2	Shredder Composition	2
2.1	Main Parts Terminology	2
2.2	Identification Plate.....	2
3	Safety	3 - 7
3.1	Safety Labels	3
3.2	Allowed Use.....	4
3.3	Improper Use	4
3.4	Workplace Safety.....	4
3.5	Operator's Requirements	4-5
3.6	Work Clothing	5
3.7	General Safety Rules.....	5-7
3.8	Transport Safety	7
4	Set-Up	8 - 11
4.1	Connecting the Machine to Tractor.....	8-9
4.2	Driveline Attachment.....	9
4.3	Hydraulic Connections	9
4.4	Machine Use	10
4.5	Working Speed	10
4.6	Machine Disconnection	10
4.7	Storage.....	11
5	Adjustments	12 - 17
5.1	Working Height Adjustment.....	12
5.2	Rear Roller Adjustment.....	13
5.3	Rear Wheel Adjustment.....	13
5.4	Side Shift Adjustment	14
5.5	Rear Hatch Adjustment	15
5.6	Belt Tension Adjustment.....	15
5.7	Wood Shredding.....	16
5.8	Feeler Arm & Spring Loader Arm (optional)	16-17
5.9	Blades and Hammers	17

TABLE OF CONTENTS

SECTION	DESCRIPTION	PAGE
6	Maintenance	18 - 22
6.1	Pre-Maintenance Check	18
6.2	Lubrication.....	19
6.3	Maintenance Schedule.....	19-20
6.4	Torque Specifications	19
6.5	To Change Oil	20
6.6	Feeler and Spring Loaded Arms.....	21
6.7	Y Blades or Hammers	22
6.8	Belt Replacement	22
6.9	Hose Replacement.....	22
7	Troubleshooting	23
7.1	Troubleshooting Table.....	23
7.2	Ordering Spare Parts	23
8	Transport & Storage	24
8.1	Working Speed	24
8.2	Road Transport	24
8.3	Storage	24
9	Technical Features.....	25
10	Parts Diagrams and Part Numbers.....	26 - 32
10.1	Flail Mower/Shredder Parts.....	26-31
10.2	Driveline Parts.....	32
11	Limited Warranty.....	33

1 GENERAL INFORMATION

1.1 INTRODUCTION:

The SFG Flails are primarily designed to mow grass, weeds and light brush.

The mowers are assembled for operation with 540 RPM tractor input only (rated PTO up to 70 HP), and supplied standard with Cat. I lift pins for tractor attachment.

The mowers can fit Cat. I quick attach hitch, by using suitable bushings to adapt diameters of lift pins.

The manufacturer reserves the right, at any time, to apply modifications to the machinery for technical or commercial reasons. Such modifications do not oblige the Manufacturer to intervene on machines sold up until that moment, nor to consider the publication inadequate.

1.2 SYMBOLS:

This booklet contains three "safety graphic symbols" which highlight the relevant danger levels or important information:



It draws the operator's attention to situations which can jeopardize people's safety.



It draws the attention to situations which jeopardize the machine efficiency but not people's safety.



It highlights general information which does not endanger people's safety or the efficiency of the parts.

2 SHREDDER COMPOSITION

2.1 MAIN PARTS TERMINOLOGY:

The machine has a working part made up of a horizontal axis rotor, upon which shredding tools are mounted, which rotate at high frequency. The shredder is made up of the following components:

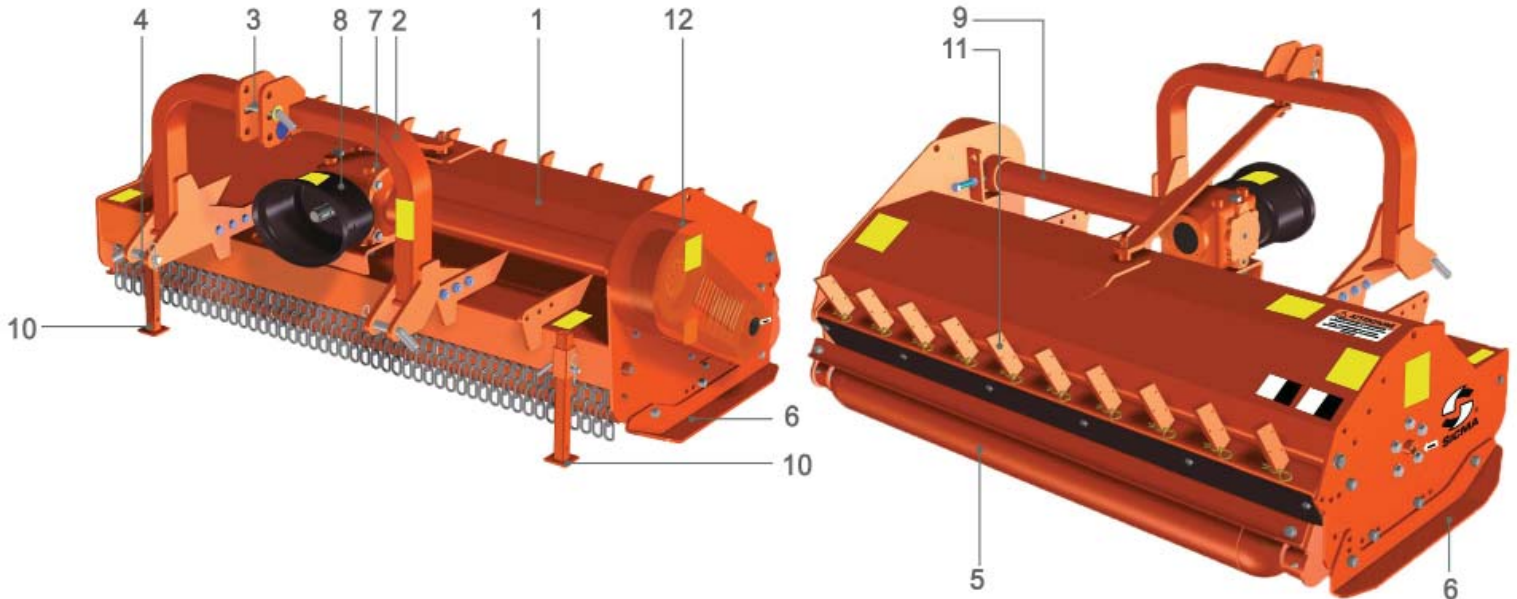

- | | |
|--------------------------|---------------------------|
| 1. Deck | 7. Gearbox |
| 2. A-Frame | 8. PTO Guard |
| 3. Upper Point Pin | 9. Lateral Gearbox Pipe |
| 4. Lower Point Pin | 10. Landing Leg |
| 5. Rear Roller | 11. Rake Teeth - Optional |
| 6. Side Skids - Optional | 12. Belt Drive Guard |

2.2 IDENTIFICATION PLATE

An identification plate is placed on every flail mower:











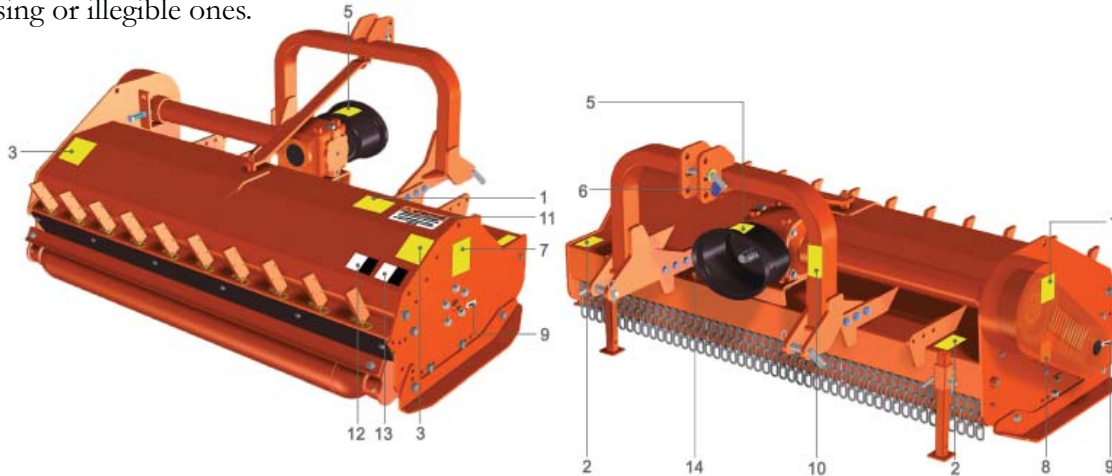



When asking for information or technical service, always specify the machine type and width.

3 SAFETY

3.1 SAFETY LABELS:

The safety labels and the information on the machine, listed in the following table, must be necessarily read and respected; failure to follow these warnings can cause death or severe injuries. Make sure that the labels are always present and legible, should this not be the case, contact your nearest Gearmore dealer to replace the missing or illegible ones.

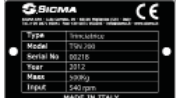

	<p>5782902 1 ATTENTION Read all instructions and safety rules carefully before using the machine. Stop engine and remove key before starting maintenance or repairs.</p>		<p>5782708 8 ENTANGLEMENT HAZARD Keep safety guards in position while operation.</p>
	<p>4781011 2 FOOT INJURY HAZARD Rotating tools; keep a safe distance from the machine.</p>		<p>4781009 9 GREASE Indication of lubricant grease injecting point.</p>
	<p>4781019 3 THROWN OBJECTS Keep a safe distance from the machine. Hand injury hazard - do not open or remove safety guards while the machine is operating.</p>		<p>4781013 10 HAND INJURY HAZARD Rotating parts - keep a safe distance from the machine.</p>
	<p>4781010 5 INPUT 540 RPM Use a 540 R.P.M. Power takeoff.</p>		<p>4781802 11 ATTENTION Machine damage hazard.</p>
	<p>4781031 6 HITCH POINT For lifting the machine.</p>		<p>4780001 14 SERIAL NUMBER PLATE</p>
	<p>4781012 7 FOOT INJURY HAZARD Keep at a safe distance from the machine.</p>		<p>5786003 12 & 13 MACHINE INFO Length information, etc.</p>

3 SAFETY (CONTINUED)

3.2 ALLOWED USE:

SFG flail mowers, as described in this instruction and maintenance booklet, have been specifically designed to mow grass, weeds, and light brush up to 2" diameter. Any other use jeopardizes the operator's safety and the machine integrity.

3.3 IMPROPER USE:

The mower was designed to mow grass, weeds, and light brush only. Only operate this mower on a properly sized and equipped tractor.

When using SFG flail mowers, it is particularly **forbidden**:

- The attachment to vehicles of unsuitable power or weight.
- To use other than 540 R.P.M. PTO speed.
- To use the machine without inserting the pins and cotter pins when supplied.
- To work in excessively stony grounds.
- To work on excessive slopes.
- To lift the machine when the power take off is engaged.
- To approach the machine when wearing inappropriate work clothing.
- To get on the machine while it is being used or transported.
- Work in reverse gear.



Operating this mower in an application for which it is not designed and/or operating with the wrong size tractor can cause mower component damage and equipment failure resulting in possible serious injury or death.

3.4 WORKPLACE SAFETY:

Most of the accidents which take place while the operator is using the machine or the equipment or during their maintenance or repair are caused by a lack of compliance with the basic safety precautions. It is necessary, therefore, to become more and more conscious of the potential risks of one's action by constantly paying attention to its effects.

If potentially dangerous situations are known, accidents can be prevented!

3.5 OPERATOR'S REQUIREMENTS:

All operators using the equipment must be competent and meet necessarily the following features:

Physical: good eyesight, coordination and capability of carrying out all functions required for the machine's use.

3 SAFETY (CONTINUED)

Mental: Capability of understanding and applying the established rules and safety precautions. Users must pay attention and be sensible for their own and other people's safety.

Training: users must have read and studied this manual, its eventual enclosed graphs and schemes and its identification and danger plates. They must be skilled and trained on any use or maintenance activities.

3.6 WORK CLOTHING:

When working and especially when executing repair or maintenance activities, it is necessary to wear the following clothing and safety accessories:

- Overalls or other comfortable clothing, not too loose to prevent the possibility that parts of them might be caught in the moving parts.
- Protective gloves for hands and mask for dust.
- Protective glasses or faceplate to protect eyes and face.
- Protective helmet for the head and safety hearing device
- Safety shoes

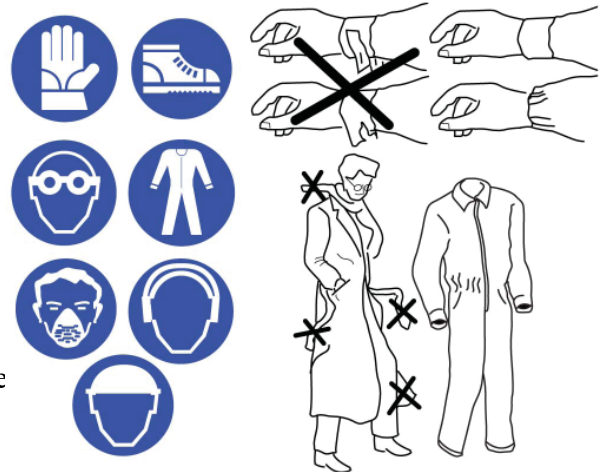

Wear only personal safety accessories in good condition and complying with the rules in force.

3.7 GENERAL SAFETY RULES:

ALWAYS CONSIDER THE FEATURES OF THE AREA WHERE WORK IS TAKING PLACE:

- When the equipment is running, it is forbidden to stand within the field of action of the shredder or of the other accessories of which it is provided with.

PREPARE THE WORK:

- Before and when working, do not drink alcohol, take drugs, or any other substances which may alter your capability of working with machine tools.
- Be sure to have sufficient fuel, to prevent a forced stopping of the machine, maybe during a critical movement.
- Do not use the equipment under unsafe conditions. For instance, it is forbidden to execute makeshift repair activities just to start working; it is forbidden to work at night with an insufficiently illuminated working area.

3 SAFETY (CONTINUED)

- NEVER operate implement without all shields in place and in good operational condition. The operator must be familiar with the mower and tractor and all associated safety practices before operating the mower and tractor.

WHEN WORKING OR DURING THE MAINTENANCE ACTIVITIES IT IS NECESSARY TO REMEMBER:

- The labels and stickers providing instructions and pointing out the dangers, must not be removed, hidden, or made illegible.
- Do not remove, except in case of maintenance, the shields, guards, and deflectors equipped on the mower. When it is necessary to remove them, stop engine, handle with care and reassemble them properly before restarting the engine and using the equipment. The mower is equipped with protective deflectors to prevent objects being thrown from the mower by the blades, however, no shielding is 100% effective. All shields, guards, and deflectors equipped on the mower must be maintained in good operational condition.
- It is forbidden to lubricate, clean and adjust the moving parts while they are running.
- During maintenance or adjustment activities on the equipment it is forbidden to use hands for executing operations for which there are specific tools.
- Do not use tools in bad condition or inappropriately, for instance pliers rather than monkey spanners, etc.
- When maintenance or repairs are completed check out that no tools, wiping rags, or other materials are left inside spaces or guides with moving parts.
- While using the equipment, it is forbidden to make more than one person give directions and make signals. The eventual directions and signals relating to the load handling must be given by one person only.
- Do not unexpectedly call an operator while he is working if not necessary; it is forbidden as well to frighten or throw objects at the operator, even if just for fun.
- Watch out for those who are present, especially the children!
- Do not allow any person to get on or ride on the machine.
- When the equipment is not needed, stop the vehicle's engine, park it on flat ground with first speed and parking brake on, remove the key, and disengage the PTO.
- Do not clean, lubricate, repair or adjust with the engine running and the machine lifted.
- Never use the machine on steep slopes which may jeopardize the equipment's stability.

The manufacturer declines all responsibility for a lack of compliance with these instructions.

3 SAFETY (CONTINUED)

- **NEVER** use gasoline, solvents, or other flammable or toxic liquids to clean mechanical parts. Use approved non-flammable, non-toxic commercial solvents.
- **DO NOT** weld near tanks, piping, cans, electrical cables or flammable materials in general. When welding, protect flammable parts with appropriate shields.

Gearmore declines all responsibility for a lack of compliance with these standards.

3.8 TRANSPORT SAFETY:

While transporting the machine it is very important to follow the road traffic code of the country where you circulate, placing particular attention on the choice of speed.

When transporting on a public road, the shredder must be in the transport position and the power take-off of the tractor must be disconnected. Machine weight changes the stability of the tractor/shredder complex, influencing steering and braking capability. Therefore proceed at a moderate speed.

Check the lifting capability and tractor stability. If needed apply ballasts on the front.

MOVEMENT AND TRANSPORTATION

Pay maximum attention to safety during loading and unloading operations, which must be carried out by qualified personnel.

When lifting the machine, use the appropriate lifting points indicated below.

The SFG shredder can be lifted by point B or hooking holes A and C simultaneously.

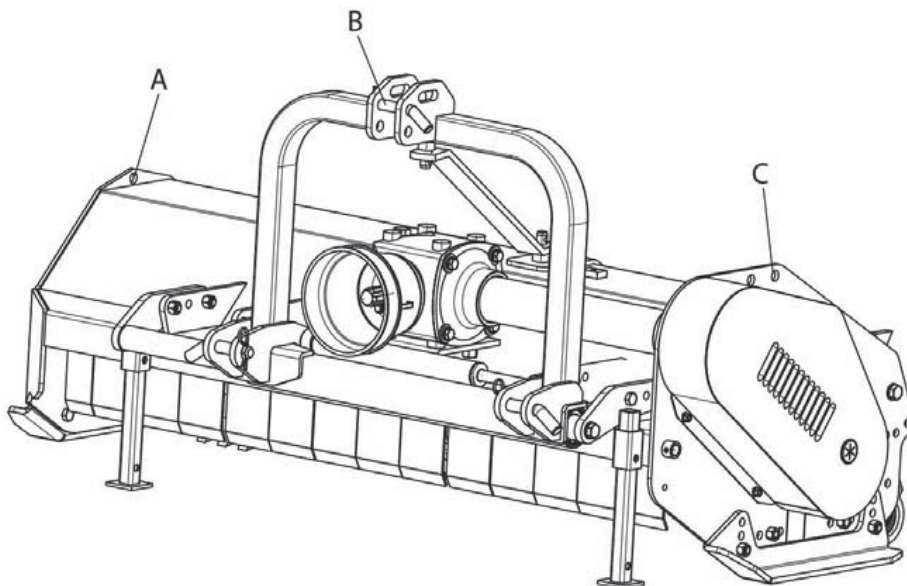

4 SET-UP

Before using the machine, one must be familiar with the controls and their work capabilities. Always keep all body parts inside of the tractor cabin, to reduce the possibility of being exposed to external dangers to a minimum.

Before exiting the tractor and before any maintenance and adjustment operation, set the parking brake, turn off the engine, remove the ignition key and wait for all moving parts to stop.

The safety of the operator and of the persons nearby depends on his ability for judgment and prudence in using the machine. Therefore the position and functions of all controls must be known well.

The machine must always be in perfect conditions and must be repaired only with original spare parts.

4.1 CONNECTING THE MACHINE TO THE TRACTOR:

It is necessary to read this instruction manual and the manuals of the tractor and driveline manufacturers. Shredders have been manufactured to be attached to any tractor provided with a hydraulic lift and a universal 3-point hitch. The machine must be connected to the tractor with a 540 R.P.M. PTO having adequate weight and power. Before attaching the equipment to the tractor, set both on a flat and smooth ground and make sure that nobody is standing between them. Move the tractor slowly towards the shredder by aligning the tractor lift's arms to the two shredder lower a-frame brackets. Stop the engine and set the parking brake.

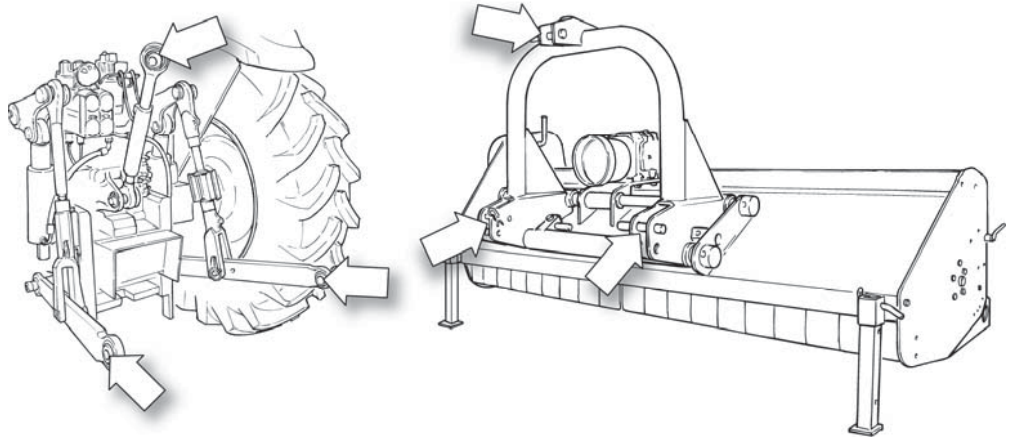

First connect the lower arms by removing the release pins of the brackets placed on the plates, inserting the lift bars into the arms center and fastening them with the relevant pins, which had been removed.

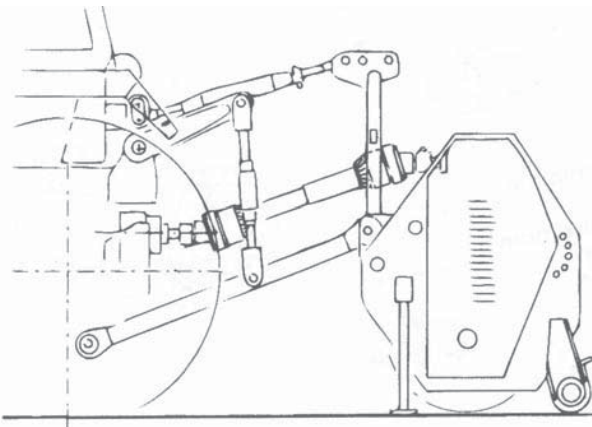

Connect the tractor top link to the third upper point by removing the pin located between the plates, inserting the top link itself and locking it with the pin. Adjust the third point so that the upper part of the frame is parallel to the ground. Lock all connection parts with the special sway chains or tie rods.

It is always good to make sure that the central group axis is parallel to the ground thus reducing the stress on the PTO and extending the working life of the equipment.

4 SET-UP (CONTINUED)

Danger

Pay attention to the tractor's front wheels grip when the equipment is set up and lifted; if the wheels appear to be too lightened, ballast the tractor front tires or add front weights.

Caution

After executing the above-mentioned activities it is always good to check that all bolts and nuts of your shredder are tightened (refer to the torque specifications in this manual).

4.2 DRIVELINE ATTACHMENT:

Before assembling the PTO shaft, it is very important to check out that its number of revolutions and direction of rotation match those of the tractor. Moreover, read the manufacturer instruction manuals of the driveline and the tractor carefully. Before starting work, check the presence of the safety guards on the PTO of the machine, of the shaft and of the tractor. Check in particular that the safety guards cover the driveline throughout its extension.

Caution

When at their maximum extension, the safety guards' plastic hoses shall overlap at least $\frac{1}{3}$ of their length. When in their maximum closed position, the minimum play allowed shall be $\frac{3}{4}$ ".

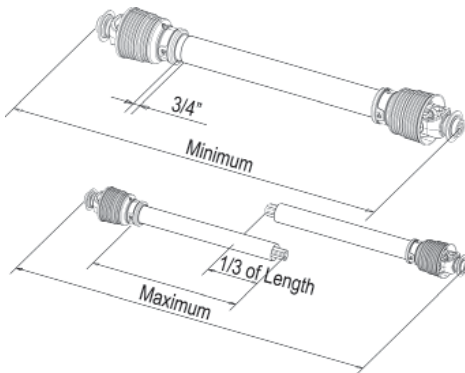

Check out that the driveline minimum and maximum length are the ones required by the machine/tractor coupling. Should problems arise, contact a skilled repair shop or the driveline retailer. After installation, secure safety guards both to the tractor and the machine using the special chains and make sure that they pivot freely. Do not use a shaft without proper safety guards complying with legal requisites. If the shaft is equipped with other safety devices, such as a pair limiter or freewheels, be sure to install them on the machine side. As for the driveline use and maintenance, refer to the relevant booklet.

Caution

Avoid going near the driveline, either in movement or stopped.

4.3 HYDRAULIC CONNECTIONS:

If your machine is provided with hydraulic movement, connect the ends of the delivery and return cylinder tubes, provided with quick coupling, to the tractor hydraulics utilities. Check the sealing of the connections and become familiar with the movements controls.

4 SET-UP (CONTINUED)

4.4 MACHINE USE:

Before using the machine for the first time, or after a long period of inactivity, carry out the following:

- √ Check that the machine is not damaged
- √ Check the mechanical parts, which must be in good condition and not rusted
- √ Check the state of wear of the blades
- √ Check that there is not oil leakage coming from fittings or piping
- √ Check that all safety guards are properly positioned

When these check-ups have been carried out, do not start the PTO with the shredder at work height but only after having lifted it up a few centimeters with the tractor lift. After this, it is possible to start engine, engage PTO, drop the machine down to work position and start using it. In the same way for operations involving change of direction, turning and going in reverse, lift the head a bit from the ground, after having disengaged the PTO, in order to avoid structure damage.

Before using the machine, one must be familiar with the controls and their work capabilities. Before starting work, make sure that no people or animals are within 100 feet. Keep the engine running at a rev speed that assures the machine the needed power for its use. Run a short way with the shredder working and check the quality of the work carried out. If it does not satisfy you, repeat and review the machine adjustment operations.

4.5 WORKING SPEED:

The tractor speed during work depends on the quality, diameter and height of the material to be cut. However it should be between 2 and 6 MPH. The PTO speed must be within 540 R.P.M.

4.6 MACHINE DISCONNECTION:

When the machine is parked, one must:

- ~ Set the parking brake
- ~ Lower the machine resting feet
- ~ Place the shredder on the ground
- ~ Disengage the tractor PTO
- ~ Turn the tractor engine off
- ~ Remove the ignition key from the control panel
- ~ Descend from the driver position
- ~ Detach the driveline
- ~ Remove a-frame pins
- ~ Get back onto the tractor, start it up and move away carefully

4 SET-UP (CONTINUED)

4.7 STORAGE:

If the machine is not to be used for long periods, it must be stored in a place sheltered from atmospheric conditions and be protected to avoid damage. Before setting it aside, clean the whole machine and lubricate all mechanical parts to protect them from rust.

Before setting the machine aside for long periods, perform the following:

- Free the rotor and the blades from shredding remains
- Wash the machine thoroughly and dry it
- Carry out a general visual control of the machine to identify structural damage, to detect deep paint abrasions, to check that all original safety decals are in place, and that they are integral and legible
- Grease all mechanical parts and fastening pins
- If possible, store the machine in a covered place, on flat and consistent ground



Used oil must be recovered and not dispersed in the environment, according to the legal standards in force. Used oil is classified as dangerous waste and as such must be brought to the appropriate collection center.

5 ADJUSTMENTS

5.1 WORKING HEIGHT ADJUSTMENT:

The machine working height is determined by the vertical position of the rear roller, by that of the skids and/or, where required, by the rear wheels.

By lifting the roller, or the wheels, the tools move closer to the ground and, vice versa, lowering the roller, and the wheels, the tools lift up from the ground. After a modification of the working height be sure that the cutters skim the ground; a direct contact with it would cause their wear.

To adjust the skid position (*fig. 1*) carry out the following operations (optional):

- Unscrew nuts **A**
- Slip the skid off
- Reinsert it in one of the holes **B**
- Tighten the nuts **A** (refer to the torque specification chart in this booklet)

Do the same thing on the opposite side of the machine.

The roller can be adjusted both horizontally and vertically.

To adjust the roller height (*fig. 2*):

- Unscrew and remove the bolts **B** which fasten the roller on both sides
- Loosen the nut **A**
- Raise or lower the roller and reposition it according to the layout
- Reinsert and tighten the bolts **B**
- Tighten the nut **A**

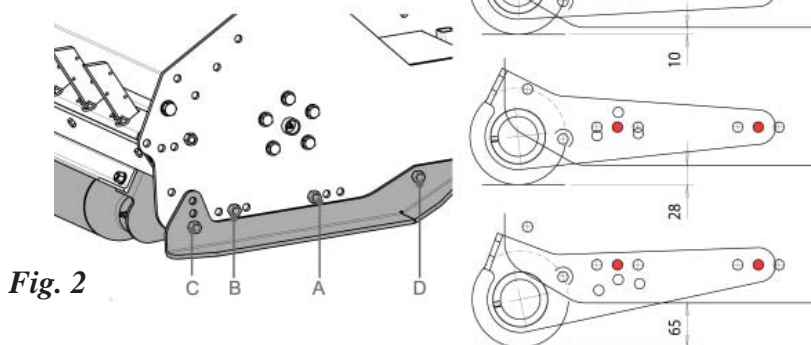

There are 3 height positions of the rear roller for blade ground clearance 1/2", 1", or 2 1/2".

! Danger

These operations shall be made only on working ground and only after having stopped the engine, disengaged the PTO and set the parking brake. If necessary, lift the machine from the ground but, in order to avoid risks for people, place it on rests thus preventing any injuries that might be caused by its sudden fall.

5 ADJUSTMENTS (CONTINUED)

5.2 REAR ROLLER ADJUSTMENT:

The roller's horizontal position must be adjusted to modify the work configuration of the shredder.

To move the roller horizontally (*fig. 2*):

- Unscrew and remove the bolts **B** and screws **A** which fasten the roller on both sides
- Place the roller at the desired position according to the layout in (*fig. 4*)
- Reinsert and tighten the bolts **A** and **B** (refer to the torque specification chart)

Fig. 4

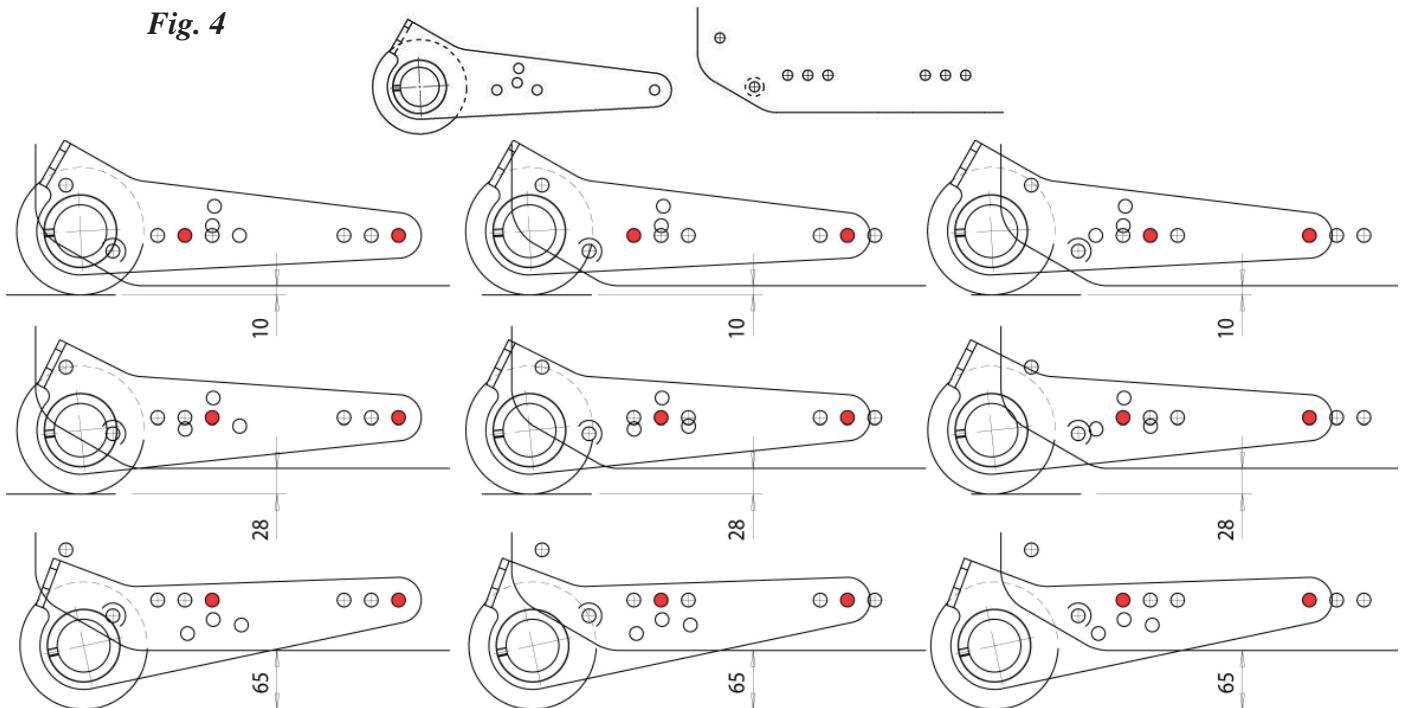

5.3 REAR WHEEL ADJUSTMENT (OPTION)

SFG options include rear wheels. To adjust the wheel height (*fig. 3*):

- Loosen the screws **E** on both sides
- Unscrew and remove the screws **F** on both sides
- Lift or lower wheels **G** through the holes **H** equally on the left and right sides
- Reinsert and tighten the screws **F**
- Tighten the screws **E**

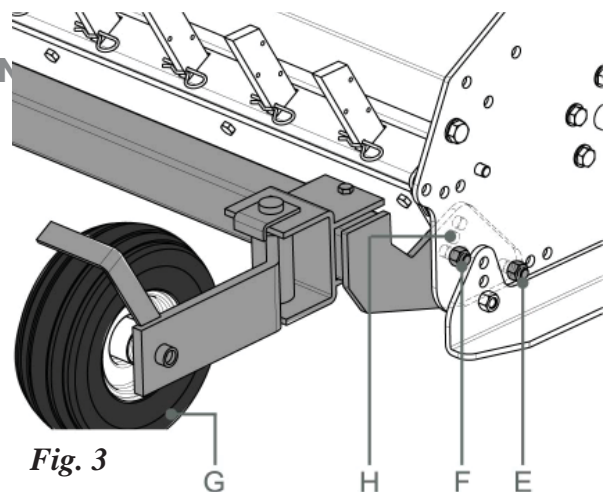

Fig. 3

5 ADJUSTMENTS (CONTINUED)

5.4 SIDE SHIFT ADJUSTMENT:

Some models of shredders can be configured in the fixed or mobile version, with manual (*fig. 5*) or hydraulic (*fig. 6*) shifting. The fixed a-frame can be mounted in only one position.

To adjust the side position of the machine with a hydraulic jack (*fig. 5*) do as follows:

- Unscrew and extract the screw A
- Move the arch to one of the allowed positions
- Reinsert the screw A and tighten the nut

If the hitch is provided with a hydraulic cylinder, it can be moved at will after having connected the quick fittings to the tractor hydraulics, using the tractor controls.

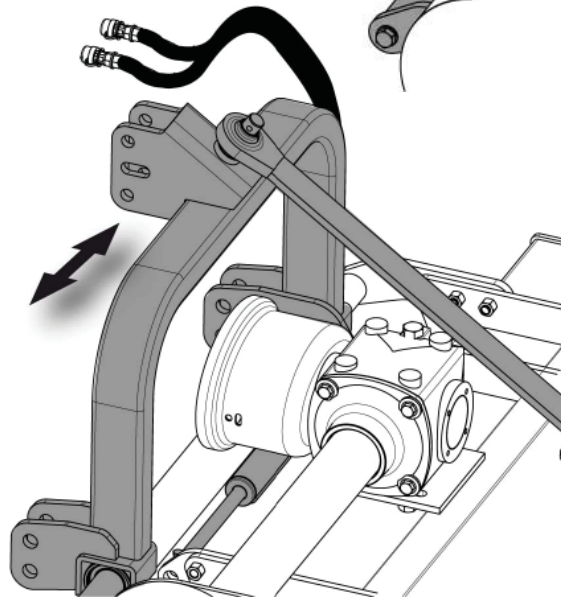
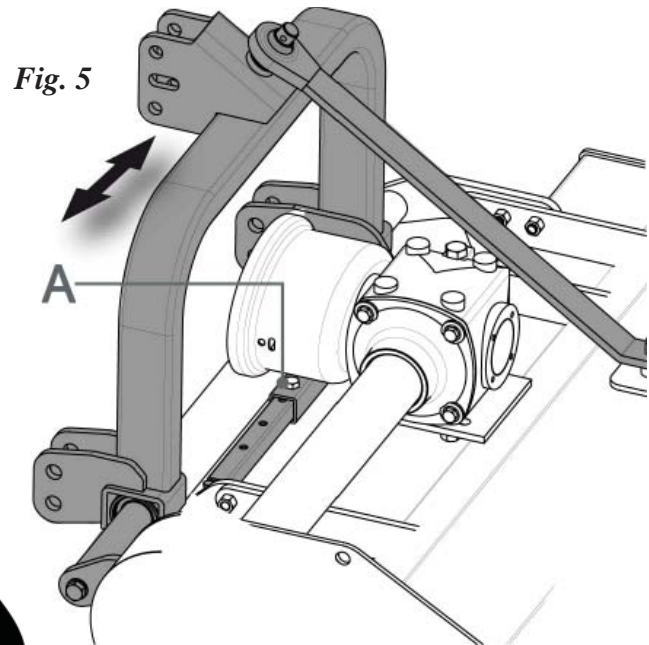

 **Danger**

Work height and side shift adjustments shall be made only on working ground and only after having stopped the engine, disengaged the PTO, and set the parking brake. If necessary, lift the machine from the ground but, in order to avoid risks for people, place it on rests thus preventing any injuries that might be caused by its sudden fall.

5 ADJUSTMENTS (CONTINUED)

5.5 REAR HATCH ADJUSTMENT:

The shredder is provided with swinging rear hatch, which can be oriented depending on the type of material to be shred.

To work in the presence of pruning remains, the baffle must be closed to obtain a better shredding. To do this, the hatch must be in the down position, to allow the rakes to be inserted (*fig. 7*).

To shred grass fields, the hatch must be open (after having removed the rakes) and the roller must be moved to the forward position to allow a better outlet for cut grass to avoid obstructions (*fig. 8*).

To adjust the hatch (*fig. 9*):

- Slide all hooks out **A**
- Loosen the screws **B** which fasten the cover on both sides
- Unscrew and remove the bolts **C**
- Rotate the cover based on the holes **D** on the side plate of the frame until reaching the desired opening
- Re-insert and tighten bolts **C**
- Tighten the screws **B** (according the torque specification chart)

Fig. 7

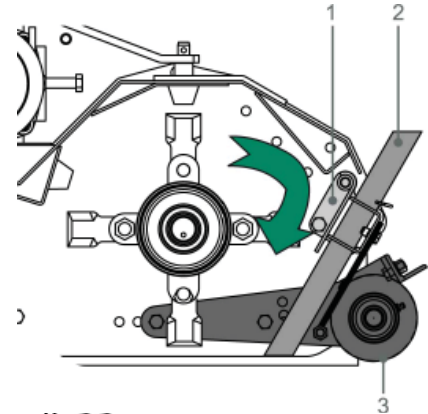

Fig. 8

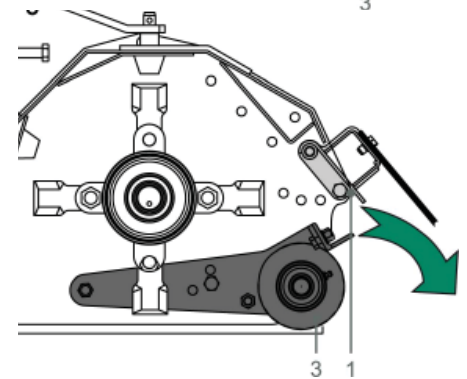
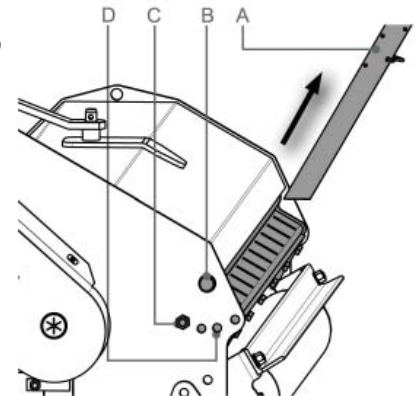

Fig. 9



5.6 BELT TENSION ADJUSTMENT:

The belt tension is correct when you can depress one belt $\frac{3}{8}$ " (1 cm) (*fig. 10*) between the two pulleys. Remove the belt protection guard **A** by loosening the 4 bolts **B**. To tighten the belts to the correct tension, loosen the 4 bolts **C** under the gearbox, loosen the lock nut **D**, then tighten the long bolt **E** on the back side of the belt guard. Next, lock the lock nut **D** to the bolt **E** once the tensioning is correct. Lastly pull the gearbox forward as much as possible before tightening the 4 bolts **C**. Re-mount the protective guard **A** by inserting and tightening the 4 bolts **B**.

Fig. 10

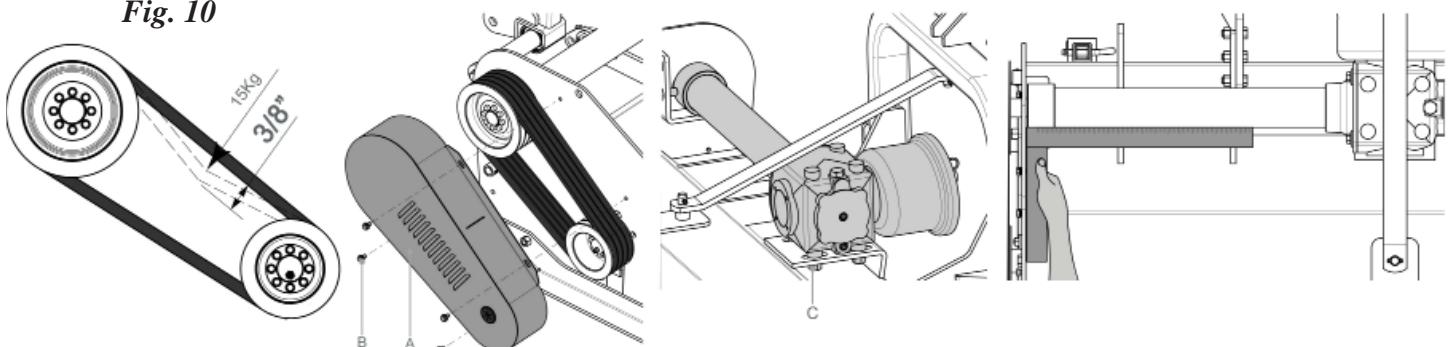

5 ADJUSTMENTS (CONTINUED)

5.7 WOOD SHREDDING:

When the shredder is equipped with hammers and with rear rakes, it is capable of shredding even larger prunings.

To place the rake teeth (*fig. 11*):

- Insert the rakes **A** into their appropriate slots
- Push them up until they skim the soil
- Insert cotter pin **B** into the appropriate hole up to needed height

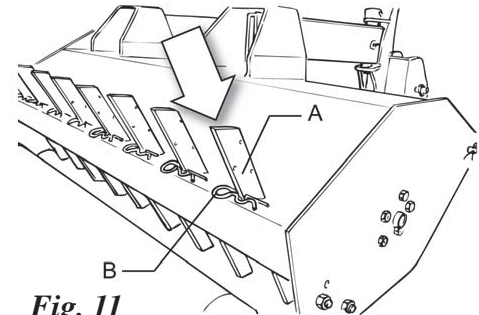

5.8 FEELER ARM & SPRING LOADER ARM (OPTIONAL):

The shredder can be equipped with a side arm which allows shredding material even in hard to reach areas during work, such as in between rows.

Side arms can be of two types:

- ❑ **FEELER ARM** - equipped with a side rod which makes the arm return (through hydraulic movement) even after hitting obstacles that are not too big (i.e. shrubs, shoots, etc.)
- ❑ **SPRING-LOADED ARM** - without the side rod, but equipped with a simple return spring which makes the arm return (through mechanical movement) only after hitting bigger objects (i.e. stakes, stocks, etc.)

Fig. 12

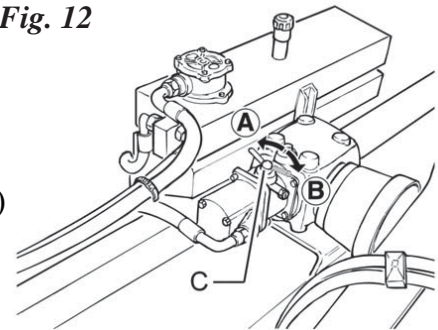

ARM ACTIVATION AND DEACTIVATION

To set in action both feeler and spring-loaded arms use lever **C** (*fig. 12*):

- Place it in position **A** to set the arm hydraulic system in action
- Place it in position **B** to deactivate the arm hydraulic system

Fig. 13

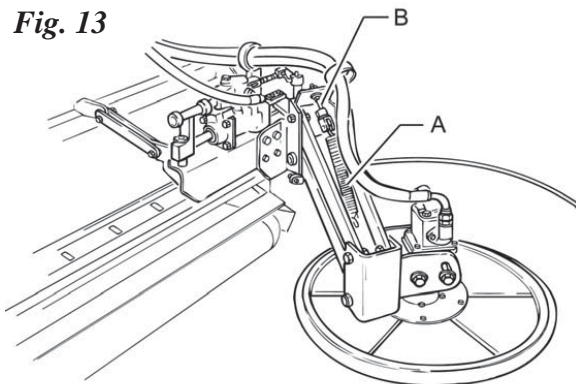

ADJUSTMENT OF THE ARM'S SENSIBILITY TO THE GROUND (FEELER AND SPRING-LOADED ARM)

The arm's sensibility to the ground can be adjusted through spring **A** (*fig. 13*) which acts on tie rod **B**, considering that tightening the tie rod **B** the arm's sensibility to the ground increases; loosening the tie rod **B** the arm's sensibility to the ground decreases

5 ADJUSTMENTS (CONTINUED)

ADJUSTMENT OF THE FEELER ARM WORKING AMPLITUDE

To adjust the working amplitude radius of the feeler arm (*fig. 14*):

- Extract the support **B**
- Adjust the length of the screw **A** considering that the shorter the screw is the greater the rod's radius amplitude (thus increasing the working amplitude)
- After adjustment, reinsert the support **B**

Fig. 14

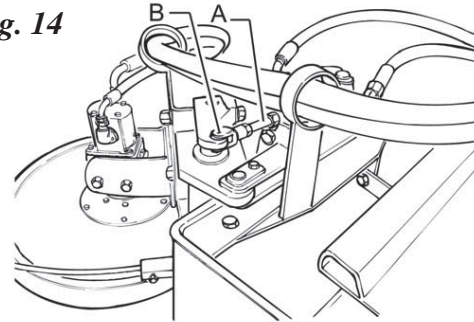

ADJUSTMENT OF SPRING LOADED ARM RESISTANCE TO OBSTACLES

Fig. 15

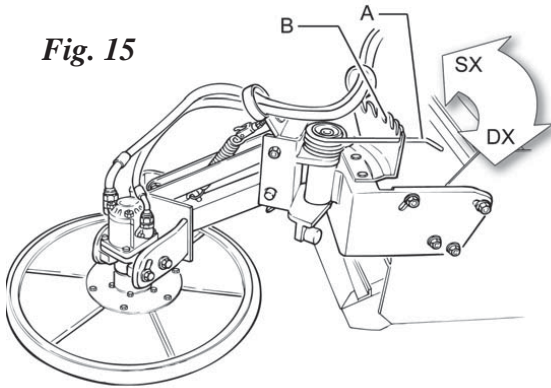

To adjust the spring loaded arm's resistance to obstacles, use the return spring **A** (*fig. 15*) moving it to the right on the hooking support **B** to decrease the arm resistance to obstacles, and vice versa to the left to increase resistance to obstacles.

! Danger

These operations shall be made only on working ground and only after having stopped the engine, disengages the PTO, and set the parking brake. If necessary, lift the machine from the ground but, in order to avoid risks for people, place it on rests thus preventing any injuries that might be caused by its sudden fall.

5.9 BLADES AND HAMMERS:

The SFG shredders can be equipped with different types of double Y blades or hammers according to the work to be done. Y Blades and hammers are interchangeable on the same rotor shaft.



ALL PURPOSE DOUBLE Y BLADES -
for grass, straw and weeds.



SMOOTH HAMMER -
for grass, pruning remains and small shrubs.

6 MAINTENANCE

6.1 PRE-MAINTENANCE CHECK:

Maintenance is a fundamental operation to extend life and performances of any agricultural vehicle; taking care of the machine grants you not only a good work execution, but also a longer life of the whole equipment and a greater safety in the workplace.

The operating times indicated in this manual have just an informative character and are referred to normal conditions of use. They can thus undergo variations according to the type of service, to the more or less dusty environment, to seasonal factors, etc.

Before starting any maintenance, the following operations must be carried out:

- The machine must be placed on flat compact ground during maintenance
- Turn the tractor engine off, set the parking brake and remove the ignition key
- Always use appropriate individual safety devices (accident prevention shoes, work overalls and gloves, anti-dust mask, etc.)
- Prepare all that is prescribed for accident prevention for the type of operation in progress
- If compressed air is used to clean the machine, appropriate glasses are needed
- Do not carry out unknown repairs. Always follow the instructions. If they are missing, contact the supplier or expert personnel
- Do not use lifting points different from those prescribed
- Make sure that the chosen lifting device is suitable to carry out operations in compliance with safety standards
- Do not leave the tractor engine running in closed places if they do not have a ventilation system suitable to remove toxic gas exhaust concentrated in the air
- Avoid prolonged and repeated skin contact with lubricants as they could harm skin and cause other problems
- In case of accidental contact with eyes, wash them well with water
- Pay maximum attention to possible elevated temperatures in drained oil
- Do not weld in closed spaces or in those which are not properly ventilated
- Do not weld on or near painted surfaces, to avoid the forming of toxic vapors. Remove paint with suitable products and then wash the surfaces and let them dry
- Discharge pressure from circuits before carrying out interventions
- Do not identify pressurized liquid leakage by hand
- Pressurized liquid leakage can penetrate the skin and eyes with very grave consequences



Caution

Before injecting lubricating grease into the zerks, clean them thoroughly to prevent mud, dust or other foreign matters from mixing up with grease, thus diminishing the lubrication effect.

When adding or changing oil, it is better to use the same oil type in order to avoid mixing oils with different features.

After the first working hour, check that all bolts and nuts are tightened; remember also to check all the machine safety guards often.

6 MAINTENANCE (CONTINUED)

6.2 LUBRICATION:

- Grease points - use high quality lithium based grease
- Gearbox - use 90 weight oil

6.3 MAINTENANCE SCHEDULE:

FIRST CHECK:

- Check the correct tension of the transmission belt
- Check that all bolts and nuts are tightened
- After the first 50 hours of work change oil in the overgear unit

EVERY 8 HOURS OF WORK:

- Grease the shaft support (transmission side) through the lubricating zerk **A** (*fig. 16*)
- Grease the shaft support (external side) through the lubricating zerk **C** (*fig. 17*)
- Grease the stabilizing roller through the lubricating zerks **D & E** (*fig. 18*)
- Grease the side shift rods through the lubricating zerk **F** (*fig. 19*)



EVERY 50 HOURS OF WORK:

- Check the correct tension of the transmission belt
- Check that all bolts and nuts are tightened
- Check the cutters/hammers for wear
- Check the gearbox oil level through plug **C** (*fig. 20*)

EVERY 500 HOURS OF WORK:

- Check that all bolts and nuts are tightened
- Change oil in the gearbox

EVERY 1000 HOURS OF WORK:

- Replace the transmission belt

6.4 TORQUE SPECIFICATIONS:

For correct hardware tightening on the mower, we suggest the use of a suitable torque wrench and the applicable torque as listed in the table.

M-THREADED SCREW / BOLTS				
Bolt Grade				
Thread	8.8		10.9	
	Nm	lb / ft	Nm	lb / ft
M6	11	8.5	17	12
M8	28	20	40	30
M10	55	40	80	60
M12	95	70	140	105
M14	150	110	225	165
M16	240	175	305	225
M18	330	250	475	350

6 MAINTENANCE (CONTINUED)

Fig. 16

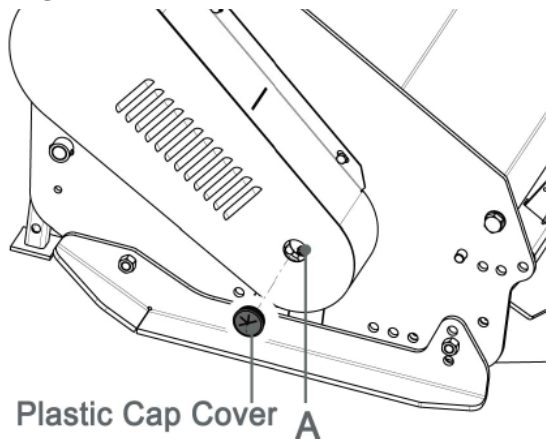

Fig. 17

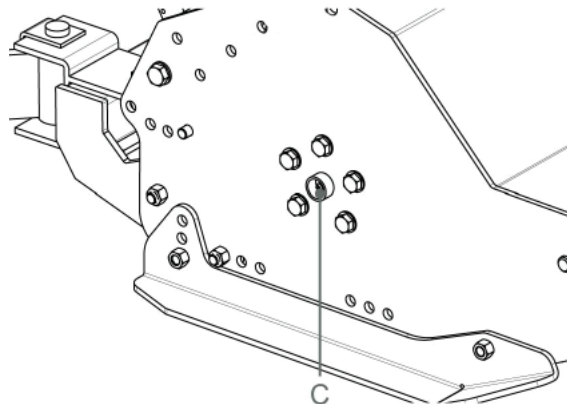

Fig. 18

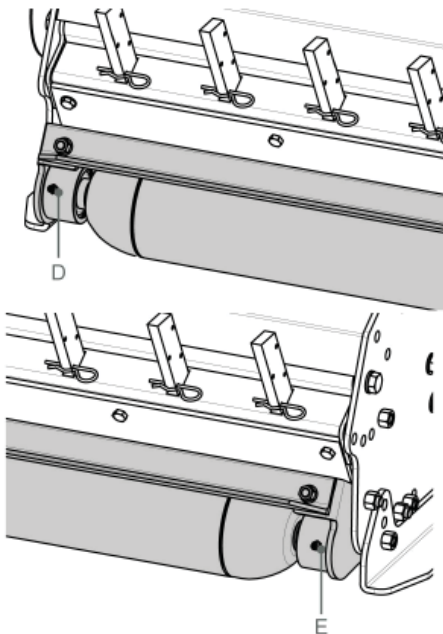

Fig. 19

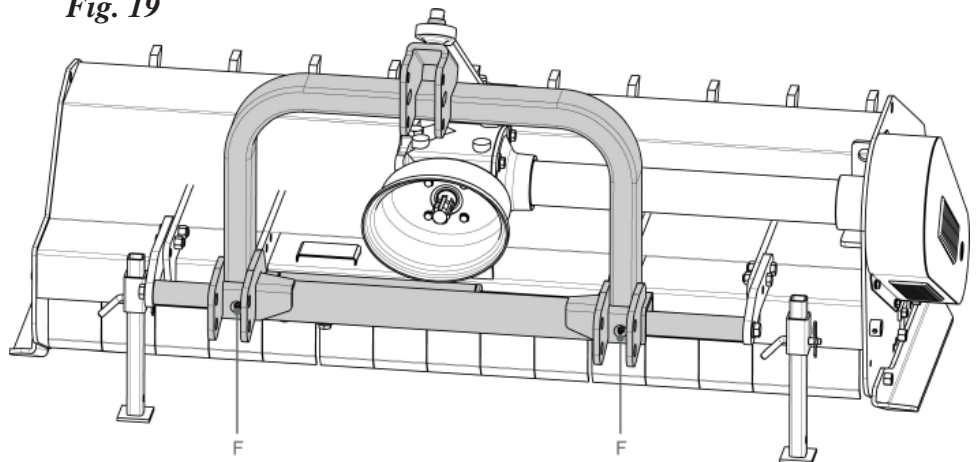
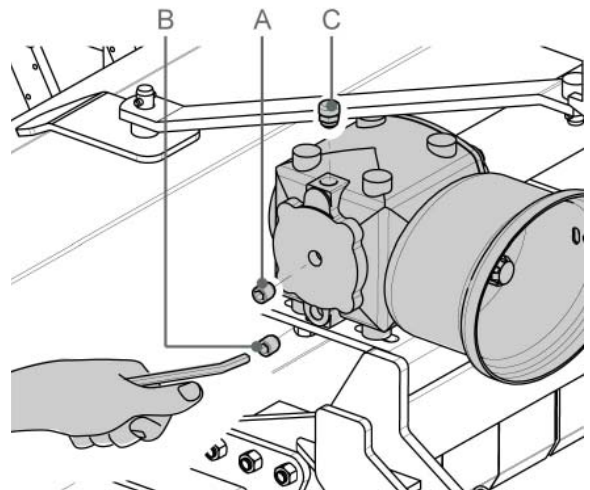

Fig. 20



6.5 TO CHANGE THE OIL:

The oil level of the gearbox must be checked visually by loosening the cap **A**. If necessary to add oil, loosen oil load cap **C** and add oil.

To change oil, position container under oil drain cap **B**. Loosen oil drain cap **B** and allow the oil to flow out completely. Dispose of the drained oil in appropriate containers for waste oils. Re-insert drain cap **B** and fill with oil through load cap **C**.

6 MAINTENANCE (CONTINUED)

6.6 FEELER AND SPRING LOADED ARMS MAINTENANCE:

FIRST CHECK:

- After the first 50 hours of work change oil in oil tank A (*fig. 21**)

EVERY 8 HOURS OF WORK:

- Grease all components of the arm through lubricating zerks A (*fig. 22 & 23*)

EVERY 50 HOURS OF WORK:

- Check oil level in tank A (*fig. 21*) through plug B.

EVERY 500 HOURS OF WORK:

- Replace oil filter C (*fig. 21**)
- Change oil in oil tank*

Fig. 21

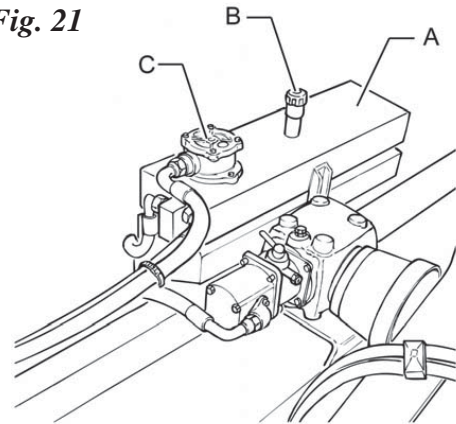

Fig. 22

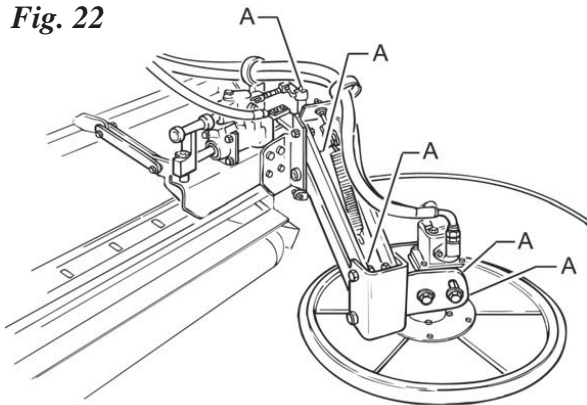
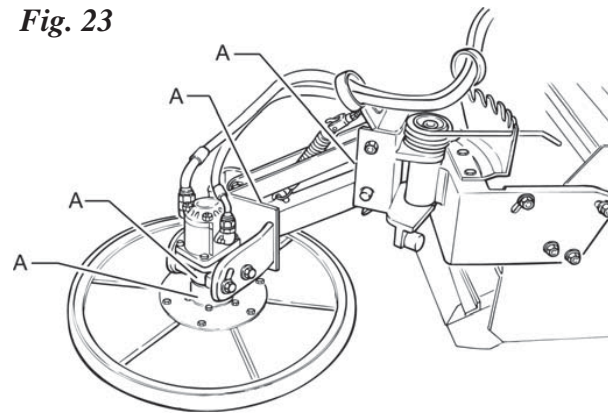

Fig. 23



*** ATTENTION:** *this maintenance activity is to be made only at an authorized repair shop.*



Caution

Used oil must be recovered and not dispersed in the environment. According to the legal standards in force, it is classified as hazardous waste and as such must be brought to the appropriate collection center.



Danger

It is forbidden to carry out maintenance without first stopping the engine, disengaging the PTO, setting the parking brake, and placing the equipment on the ground.

6 MAINTENANCE (CONTINUED)

6.7 Y BLADES OR HAMMERS:

To assure a perfect functioning of the machine, check often (at least every 50 hours of work) that the shredder's hammers are in good condition and perfectly fixed by the locking bolts; in case they are broken replace them with new original spare parts.

For any blade or hammer replacements, please contact your authorized Gearmore dealer.



Before starting the inspection of blades or hammers, stop the engine, set the parking brake, and disengage the PTO. Then raise the shredder with the tractor lift and place it on rests to avoid an accidental fall.

When one blade is replaced, it is advisable to replace the whole series. Use of unoriginal blades can cause vibrations of the machine.

When replacing blades with the machine lifted, do not trust the capacity of the tractor's hydraulic lift. Insert mechanical posts or support tripods between the machine and the ground in order to avoid unwanted and dangerous situations.

6.8 BELT REPLACEMENT:

To replace the belts, proceed as follows:

- Loosen the long bolt on the back side of the belt guard
- Loosen the 4 bolts on the underside of the gearbox.
- Pull back on the gearbox and cross shaft until the belts are loose.
- Extract the damaged belt(s).
- Insert the new belt(s).
- Tighten the main cross shaft bolt and stop nut.
- Pull forward and tighten the 4 gearbox bolts.
- For desired tension see ***Belt Tension Adjustment*** (page 15).

If only one belt is damaged, it is advisable to replace them all to guarantee a better force distribution on each belt.

The pulleys are integrated with the transmission shafts by means of locking collars. The tightening torque to be applied to the screws of the locking collars - 30 ft./lbs.

6.9 HOSE REPLACEMENT:

Before hose replacement, take the safety measures intended for maintenance. After having closed the hydraulic valves, make sure that there is no residual pressure in the circuit. Loosen the connection points of the damaged hose, paying attention to possible oil leakage. Replace the damaged hose with an original spare part making sure of the good condition of the relative fitting. Tighten the hose fittings carefully to avoid damaging the threading and check the sealing of the restored circuit.

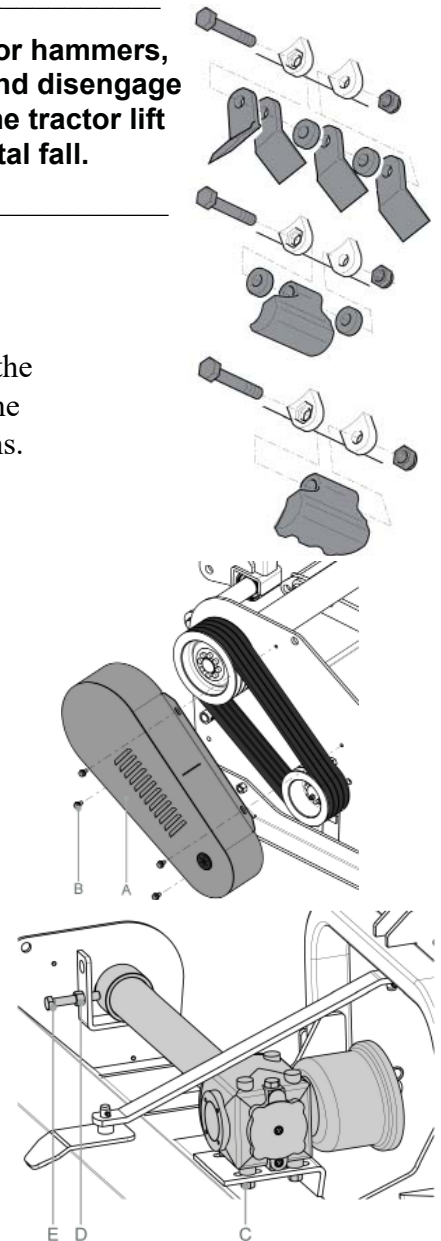

7 TROUBLESHOOTING

7.1 TROUBLESHOOTING TABLE:

PROBLEM	CAUSE	REMEDY
Oil leak from the gear transmission box	● Too much oil in the box	● Restore the correct oil level
	● Vent cap has faulty valve	● Replace the vent cap
	● Load/drain/level caps loose	● Tighten the load/drain/level caps
	● Damaged gaskets	● Replace gaskets
Shredding not uniform	● Worn or damaged blades	● Replace the blades
	● Machine not well adjusted on rear roller	● Carry out adjustments
	● Machine clogged	● Decrease speed
Bevel gear unit overheating	● Insufficient oil	● Add oil
	● No oil	● Restore the oil level
	● Material difficult to shred	● Reduce advancement speed
Blades wear	● Stony ground	● Previous inspection of the ground
	● Tool cutting height too low	● Adjust cutting height
Machine noise or vibrations	● Unbalanced rotor	● Balance in specialized work shop
	● Damaged, worn, or missing blades	● Replace the blades
	● Worn bearings	● Replace bearings

7.2 ORDERING SPARE PARTS:

Where replacement parts are necessary for periodic maintenance and servicing, genuine factory replacement parts **must** be used to restore your equipment to original specifications. The manufacturer will not be responsible for injuries or damages caused by use of unapproved parts and/or accessories.

Request of spare parts must be made to your authorized Gearmore dealer and must always be completed with the following information:

- Type and width of the equipment
- Part number of the needed spare part
- Denomination of the needed part and desired quantity

QUANTITY CHART - KNIVES/HAMMERS							
Part No.	Description	SFG95	SFG125	SFG140	SFG155	SFG185	SFG200
5816274	Knife	24	32	40	40	48	56
5536128	Knife Spacer	12	16	20	20	24	28
5716003	Screw M20 x 146	6	8	10	10	12	14
3464101020	Nut M20	6	8	10	10	12	14
5715104	Smooth Hammer	6	8	10	10	12	14
5535001	Smooth Hammer Spacer	12	16	20	20	24	28
5706109	Notched Hammer	6	8	10	10	12	14

8 TRANSPORT & STORAGE

8.1 WORKING SPEED:

The working speed depends on quality, diameter and height of the material to be cut; anyway, for efficient mower performance it must be between 2 and 5 MPH. The power takeoff speed must be 540 RPM maximum. Operate the mower at its full rated PTO speed to maintain blade speed for a clean cut.



Do not exceed the rated PTO speed for the implement. Excessive PTO speeds can cause driveline or blade failures resulting in serious injury or death.

8.2 ROAD TRANSPORT:

Extreme caution should be used when transporting the tractor and implement on public roadways. The tractor must be equipped with all required safety warning features including a SMV emblem and flashing warning lights which are clearly visible from the rear of the unit. Make sure you are in compliance with all local regulations regarding transporting equipment on public roads and highways. Do not exceed 20 MPH (32 kph). Reduce speed on rough roads and surfaces. Always use hazard flashers on the tractor when transporting unless prohibited by law.

8.3 STORAGE:

If your shredder will not be used for a long period of time, respect the following suggestions:

1. Wash the machine thoroughly and dry it.
2. Lubricate all bearings with enough grease to eliminate any cavities where water condensation may occur and cause damage. Refer to "Maintenance of the Machine" for location of all grease fittings. Be sure the vent on top of the gearbox is open.
3. Loosen the set nut and spindle jack to relieve drive belt tension (NOTE: Before next season's use, be sure to adjust the drive belt tension.)
4. Coat all exposed surfaces inside the mower with oil or grease to prevent rusting and pitting during storage.
5. Protect the whole machine with a tarpaulin and put it in a dry place.

PRE-SEASON CHECK

1. Check the oil level in the gearbox and lubricate all bearings. See "Lubrication".
2. Adjust drive belt tension. See "Belt Drive".
3. Check out all equipment and replace damaged or worn parts.
4. Tighten all bolts and nuts (See "Torque Specifications").
5. Inspect for missing and/or broken blades/knives. Replace as necessary. See "Knife Replacement".
6. Be sure that the safety guards are in place and secure.
7. Run the Flail Mower at a low RPM checking to make sure that all driveline parts are moving freely.

9 TECHNICAL FEATURES

Below find the table stating the technical features of the SFG Shredder.

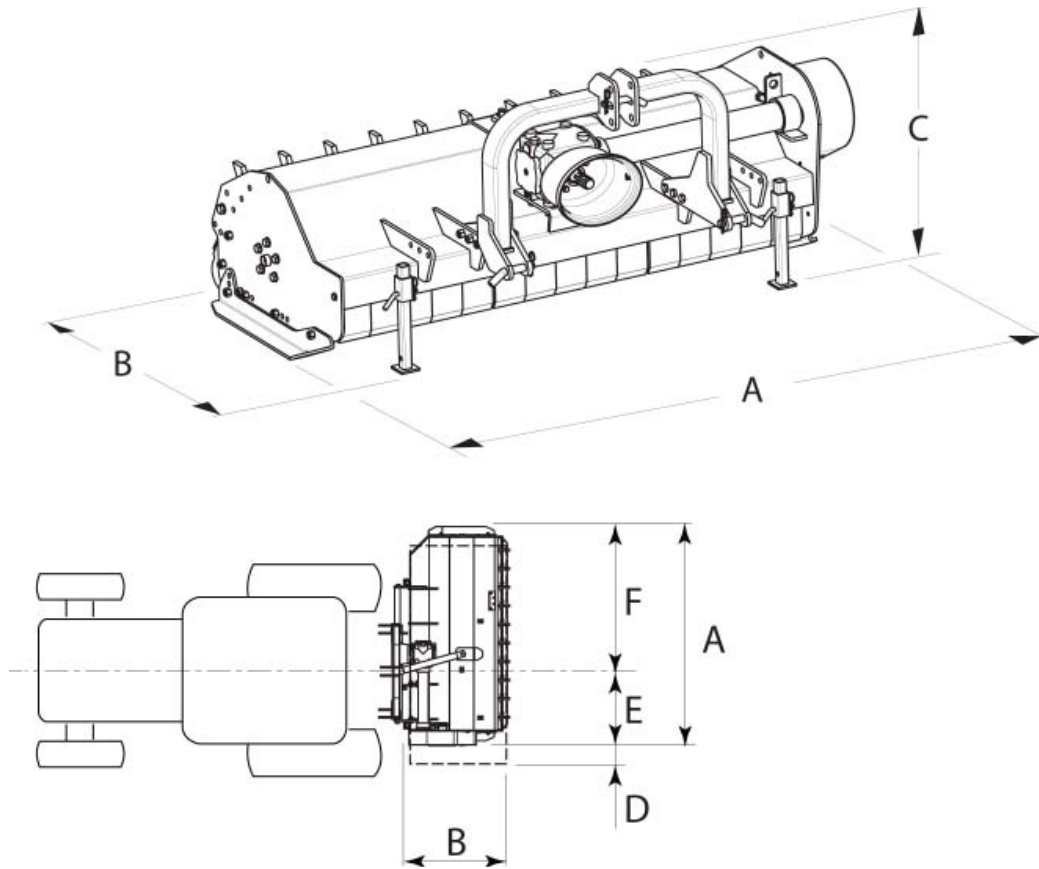

TECHNICAL FEATURES							
Fixed / Moveable SFG							
Ref.	Description	SFG95	SFG125	SFG140	SFG155	SFG185	SFG200
	Working Width:	38"	49"	55"	61"	73"	79"
A	Overall Width:	43"	55"	61"	67"	78"	84"
B	Overall Length:	45"	45"	45"	45"	45"	45"
C	Height:	34"	34"	34"	34"	34"	34"
	Weight:	660#	770#	810#	880#	1005#	1100#
	R.P.M.	540	540	540	540	540	540
	Horsepower Req'd:	20	25	30	35	40	45
	Smooth Hammers:	6	8	10	10	12	14
	Notched Hammers:	6	8	10	10	12	14
	Standard Y Knives:	24	32	40	40	48	56
Moveable SFG							
	Weight:			843#	900#	993#	1070#
D	Offset:			44" to 48"	44" to 48"	44" to 48"	44" to 48"
E				18.86"	18.66"	25.35"	25.35"
F				36.57"	42.68"	47.80"	53.70"

10 PARTS

10.1 FLAIL MOWER/SHREDDER PARTS:

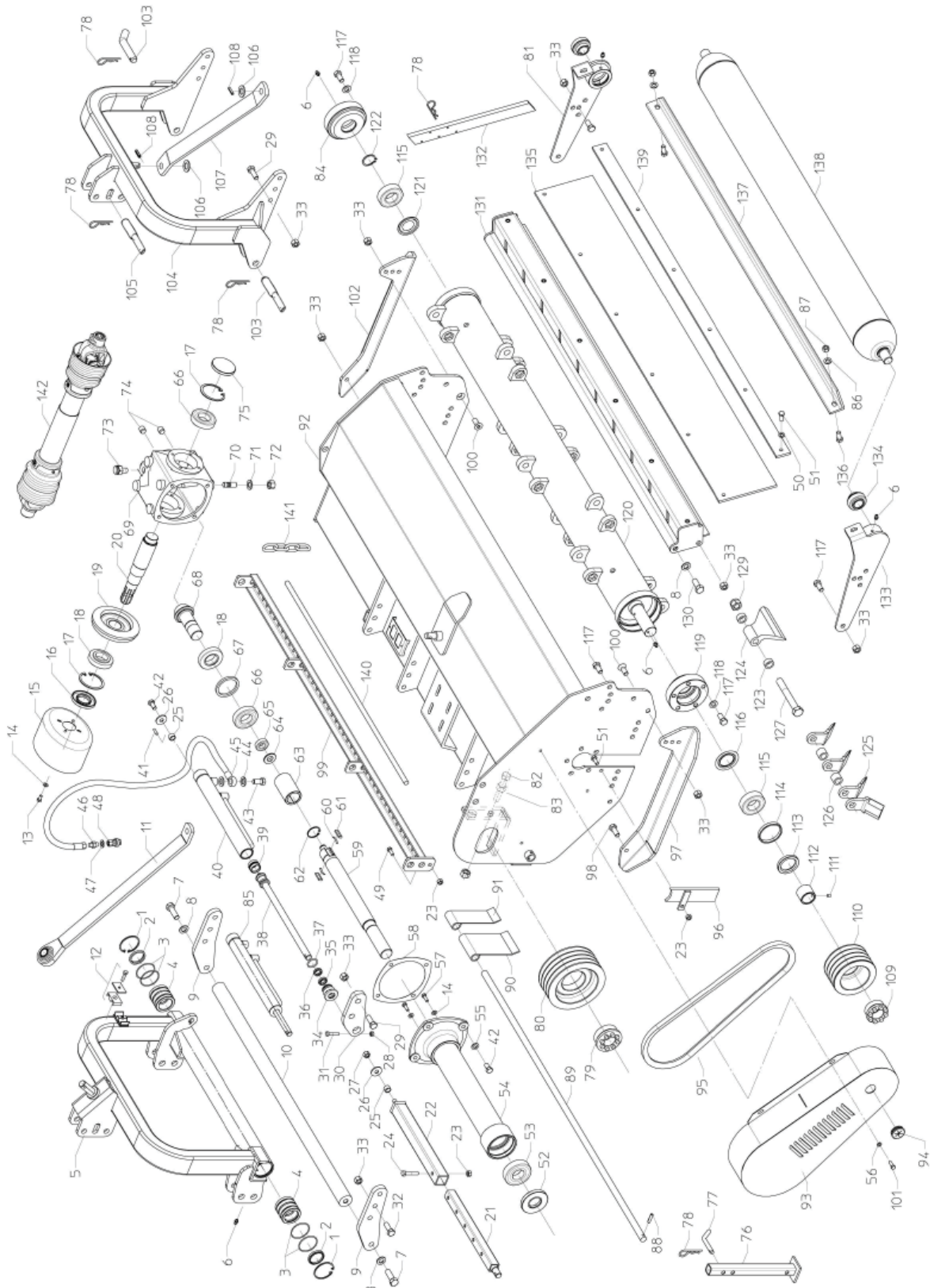

10 PARTS (CONTINUED)

<u>REF.</u>	<u>QTY.</u>	<u>PART NO.</u>	<u>DESCRIPTION</u>
1	2	6310065	Circlip External UNI 7435
2	2	6038342	Oil Scraper WRM 177208
3	4	6800836	O-Ring 836
4	2	4782300	Bushing
5	1	5007264	Shifting Arc
6	7	6560008	Grease Nipple M8 UNI 7663-A
7	2	3011116040	Screw Hex Head UNI 5737 PG 8.8 M16 x 40 ZnB
8	2	3635100016	Washer F1AT 10188 C70 Di.16 ZnB
9	2	5937221	Shaft Support Plate
10	1	5427203	Shaft
11	1	5007263	Rod
12	1	6832044	Tube Lock Kit
13	4	3021108016	Screw UNI 5739 M8 x 16 8.8
14	6	3604100008	Washer UNI 6592 140HV D8 ZnB
15	1	1883512	PTO Guard
16	1	6104080	Oil Seal 40 x 80 x 10 DIN 3760 Type A
17	2	6310080	Circlip Internal 80 UNI 7437
18	2	2730208	Bearing 30208
19	1	1721008	Bevel Gear Z27
20	1	1221004	PTO Shaft
21	1	5007293	Internal Tube, Manual Shift
22	1	5007254	External Tube, Manual Shift
23	5	3444101010	Self Locking Nut DIN 980 M10
24	1	3021110055	Screw Hex Head UNI 5739 PG 8.8 M10 x 55 ZnB
25	1	4532393	Spacer
26	1	3614100012	Large Washer UNI 6593 100HV D12 ZnB
27	1	3445101012	Self Locking Nut DIN 980 M12
28	1	3444101008	Self Locking Nut DIN 980 M8
29	As Req'd	3021114040	Screw Hex Head UNI 5739 PG 8.8 M14 x 40 ZnB
30	1	5007292	Piston Rod Locking Plate
31	1	3011108040	Screw Hex Head UNI 5739 PG 8.8 M8 x 40 ZnB
32	2	3021114045	Screw Hex Head UNI 5739 PG 8.8 M14 x 45 ZnB
33	20	3444101014	Self Locking Nut DIN 980 M14
34	1	4641401	Piston Lock Nut
35	1	6038320	Oil Scraper WRM 078110
36	1	6038020	Seal B 110078
37	1	6036216	O-Ring 216
38	1	5007296	Piston Rod
39	1	6038280	Seal DBM 137098
40	1	5007249	Cylinder Liner
41	1	6330626	Spring Pin D6 x 26 UNI 6873
42	5	3021112025	Screw Hex Head UNI 5739 PG 8.8 M12 x 25
43	2	6421904	Drilled Screw 3/8"
44	4	6470038	Washer 3/8"

10 PARTS (CONTINUED)

<u>REF.</u>	<u>QTY.</u>	<u>PART NO.</u>	<u>DESCRIPTION</u>
45	2	64126200	Tube R1AT 3/8" Lg. 2000
46	2	6037390	Nipple 1/2 - 3/8"
47	2	6037012	Washer 1/2"
48	2	6037683	Quick Release
49	1	3021110030	Screw Hex Head UNI5739 PG 8.8 M10 x 30 ZnB
50	As Req'd	3604100010	Washer UNI 6592 140 HV M10
51	As Req'd	3021110025	Screw Hex Head UNI 5739 PG 8.8 M10 x 25
52	1	6104090	Oil Seal 40 x90 x 12 DIN 3760 Type A
53	1	2106308	Bearing 6308
54	1	1001047	Flanged Tube SFG-095
54	1	1001049	Flanged Tube SFG-125
54	1	1001050	Flanged Tube SFG-140
54	1	1001051	Flanged Tube SFG-155/SFG-185/SFG-200
55	4	3635100012	Washer F1AT 10188 C70 Di. 12 ZnB
56	3	3604100008	Washer UNI 6592 140 HV D8 ZnB
57	2	3021108025	Screw Hex Head UNI 5739 PG 8.8 M8 x 25 ZnB
58	1	1781041	Gasket
59	1	1201005	Shaft SFG-095
59	1	1201007	Shaft SFG-125
59	1	1201008	Shaft SFG-140
59	1	1201009	Shaft SFG-155/SFG-185/SFG-200
60	2	1811001	Spring
61	2	1321001	Free Wheel Key
62	1	6310042	Circlip Internal 42 UNI 7437
63	1	1221001	Junction Tube
64	1	1201012	Bearing Spacer
65	1	2106004	Bearing 6004
66	1	2106208	Bearing 6208
67	1	1591068	Bearing Spacer
68	1	1721007	Bevel Pinion Z9
69	1	1641001	Gearbox
70	4	5306298	Stud Screw M16
71	4	3604100016	Washer UNI 6592 140HV D16 ZnB
72	4	3444101016	Self Locking Nut DIN 980 M16
73	1	3442018	Pressure Relief Plug M18 x 1.5
74	2	3441018	Fill Plug M18 x 1.5
75	1	6100080	Cover
76	2	5006768	Stand Leg
77	2	4236115	Stand Leg Pin
78	As Req'd	6351004	Cotter Pin D4
79	1	6364080	Tapered Locking Unit VK 156 40/80
80	1	5646501	Driving Pulley SPB4 190
81	1	5007210	Right Roller Support
82	1	3021116090	Screw Hex Head UNI5739 PG 8.8 M16 x 90 ZnB

10 PARTS (CONTINUED)

<u>REF.</u>	<u>QTY.</u>	<u>PART NO.</u>	<u>DESCRIPTION</u>
83	2	3414102016	Nut M16 PG UNI 5587
84	1	5706099	Rotor Support External Side
85	1	5007248	Hydraulic Cylinder
86	2	3604100012	Washer UNI 6592 140 HV Di. 12 ZnB
87	2	3444101012	Self Locking Nut DIN 980 PG. M12 ZnB
88	1	6330836	Spring Pin D8 x 36 UNI 6873
89	1	5237301	Chain Support Rod SFG-095
89	1	5237303	Chain Support Rod SFG-125
89	1	5237304	Chain Support Rod SFG-140
89	1	5237305	Chain Support Rod SFG-155
89	1	5237307	Chain Support Rod SFG-185
89	1	5237308	Chain Support Rod SFG-200
90	As Req'd	5136109	Shield Plate
91	As Req'd	5136108	Shield Plate Narrow
92	1	5007280	Frame SFG-095
92	1	5007282	Frame SFG-125
92	1	5007283	Frame SFG-140
92	1	5007284	Frame SFG-155
92	1	5007285	Frame SFG-185
92	1	5007286	Frame SFG-200
93	1	5007291	Belt Cover
94	1	6603516	Lubrication Plug
95	4	6721320	Belt XPB1320
96	1	5007290	Closing Plate
97	1	5137323	Left Skid
98	2	3021112035	Screw Hex Head UNI 5739 PG 8.8 M10 x 35 ZnB
99	1	5007305	Chain Holder SFG-095
99	1	5007307	Chain Holder SFG-125
99	1	5007308	Chain Holder SFG-140
99	1	5007309	Chain Holder SFG-155
99	1	5007310	Chain Holder SFG-185
99	1	5007311	Chain Holder SFG-200
100	2	3062214035	Countersunk Screw UNI 5933 PG 8.8 M14 x 35
101	3	3021108020	Screw Hex Head UNI 5739 PG 8.8 M8 x 20 ZnB
102	1	5137322	Right Skid
103	2	4208292	Lower Link Step Pin Cat. 1 & 2
104	1	5007267	Fixed Arc
105	1	4309180	Top Link Step Pin Cat. 1 & 2
106	2	3604100020	Washer UNI 6592 140 HV D20 ZnB
107	1	5137271	Fixed Arc Rod
108	2	6330832	Elastic Pin 8 x 32

10 PARTS (CONTINUED)

<u>REF.</u>	<u>QTY.</u>	<u>PART NO.</u>	<u>DESCRIPTION</u>
109	1	6374065	Tapered Locking Unit VK 156 40/65
110	1	5645801	Driven Pulley SPB4 140
111	1	31106006	Set Screw M6 x 6 PG UNI 5927
112	1	5536534	Driven Pulley Spacer
113	1	6205072	Oil Seal 50 x 72 x 10 DIN 3760 Type AS
114	1	5596108	Oil Seal Holder
115	2	2822208	Bearing 22208
116	1	2122208	NILOS 22208/JV
117	16	3021114030	Hex Head Screw UNI 5739 PG 8.8 M14 x 30 ZnB
118	10	3635100014	Washer F1AT 10188 C70 D14 ZnB
119	1	5706098	Rotor Support
120	1	5006053C	Balanced Rotor SFG-095 Y Blades
120	1	5006053ML	Balanced Rotor SFG-095 Smooth Hammers
120	1	5006074C	Balanced Rotor SFG-125 Y Blades
120	1	5006074ML	Balanced Rotor SFG-125 Smooth Hammers
120	1	5006075C	Balanced Rotor SFG-140 Y Blades
120	1	5006075ML	Balanced Rotor SFG-140 Smooth Hammers
120	1	5006076C	Balanced Rotor SFG-155 Y Blades
120	1	5006076ML	Balanced Rotor SFG-155 Smooth Hammers
120	1	5006077C	Balanced Rotor SFG-185 Y Blades
120	1	5006077ML	Balanced Rotor SFG-185 Smooth Hammers
120	1	5006079C	Balanced Rotor SFG-200 Y Blades
120	1	5006079ML	Balanced Rotor SFG-200 Smooth Hammers
121	1	2022208	NILOS 22208/AV
122	1	6320040	Circlip Internal 40 UNI 7435
123	As Req'd	5535001	Smooth Hammers Spacer
124	As Req'd	5715104	Smooth Hammer
125	As Req'd	5816274	Y Blade
126	As Req'd	5536128	Blade Spacer
127	As Req'd	5716003	Screw Hex Head 20 x 146 UNI 5737
129	As Req'd	3464101020	Self Locking Nut UNI 7473 8 (6s) PG.M20 ZnB
130	2	3021116040	Screw Hex Head UNI 5739 PG 8.8 M16 x 40 ZnB
131	1	5007220	Rake Hatch SFG-095
131	1	5007222	Rake Hatch SFG-125
131	1	5007223	Rake Hatch SFG-140
131	1	5007224	Rake Hatch SFG-155
131	1	5007226	Rake Hatch SFG-185
131	1	5007227	Rake Hatch SFG-200
132	As Req'd	5836084	Rake
133	1	5007211	Left Roller Support
134	1	2030030	Bearing UC-206

10 PARTS (CONTINUED)

<u>REF.</u>	<u>QTY.</u>	<u>PART NO.</u>	<u>DESCRIPTION</u>
135	1	5787201	Rubber Safety Shield SFG-095
135	1	5787203	Rubber Safety Shield SFG-125
135	1	5787204	Rubber Safety Shield SFG-140
135	1	5787205	Rubber Safety Shield SFG-155
135	1	5787207	Rubber Safety Shield SFG-185
135	1	5787208	Rubber Safety Shield SFG-200
136	2	3021112030	Screw Hex Head UNI 5739 PG 8.8 M12 x 30 ZnB
137	1	5856001	Roller Scraper SFG-095
137	1	5856004	Roller Scraper SFG-125
137	1	5856005	Roller Scraper SFG-140
137	1	5856006	Roller Scraper SFG-155
137	1	5856007	Roller Scraper SFG-185
137	1	5856011	Roller Scraper SFG-200
138	1	5008011	Rear Roller SFG-095
138	1	5008013	Rear Roller SFG-125
138	1	5008001	Rear Roller SFG-140
138	1	5008015	Rear Roller SFG-155
138	1	5008016	Rear Roller SFG-185
138	1	5008017	Rear Roller SFG-200
139	1	5837201	Safety Shield Plate SFG-095
139	1	5837203	Safety Shield Plate SFG-125
139	1	5837204	Safety Shield Plate SFG-140
139	1	5837205	Safety Shield Plate SFG-155
139	1	5837207	Safety Shield Plate SFG-185
139	1	5837208	Safety Shield Plate SFG-200
140	1	5237301	Chain Rod SFG-095
140	1	5237303	Chain Rod SFG-125
140	1	5237304	Chain Rod SFG-140
140	1	5237305	Chain Rod SFG-155
140	1	5237307	Chain Rod SFG-185
140	1	5237308	Chain Rod SFG-200
141	As Req'd	5506701	Chain 4 Links
142	1	E8200612	Driveline AX6 460/696 1026010-1026010 CE SS
142	1	E8200604	Driveline AX6 490/726 1026010-1026010 CE SS
142	1	E8200615	Driveline AX6 610/846 1026010-1026010 CE SS

10 PARTS (CONTINUED)

10.1 DRIVELINE PARTS:

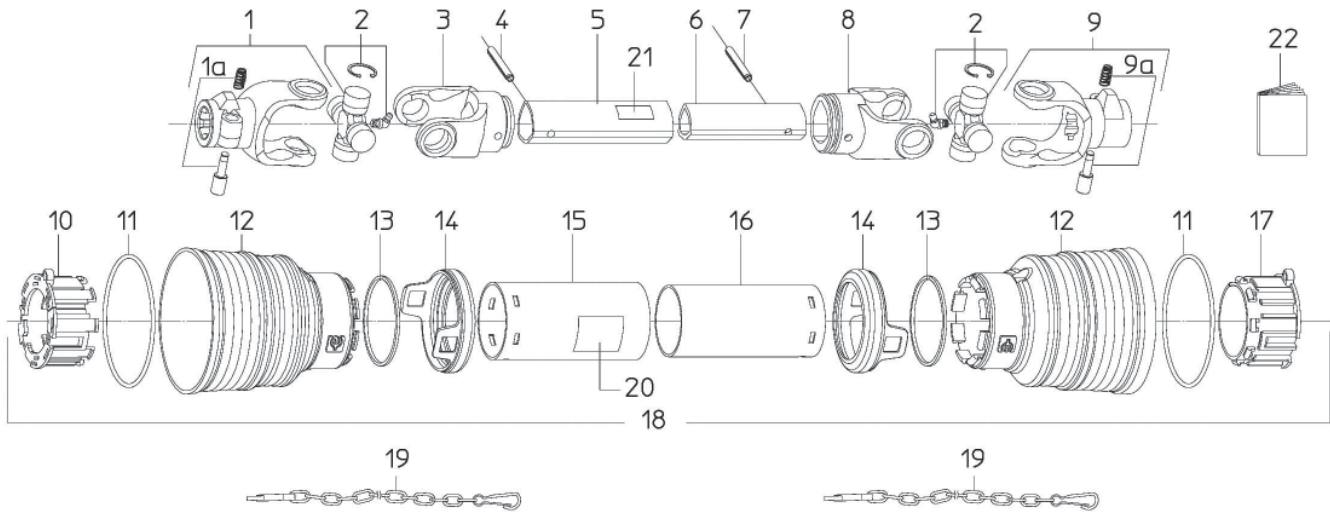

REF.	QTY.	PART NO.	DESCRIPTION
1	1	10206010	Yoke Assembly (Tractor End)
1a	1	1581038	Push Pin Kit
2	2	1006020	Cross Assembly
3	1	1706027	Outer Tube Yoke
4	1	6331080	Roll Pin Outer Tube 10 x 80 1485 DIN
5	1	1528044	Outer Tube
6	1	1526044	Inner Tube
7	1	6331070	Roll Pin Inner Tube 10 x 70 1485 DIN
8	1	1706029	Inner Tube Yoke
9	1	1026010	Yoke Assembly (Implement End)
9a	1	1581038	Push Pin Kit
10	1	1786710	Tube Bearing Outer Tube
11	2	1215733	Stiffening Ring
12	2	1785703	Standard Cone
13	2	1215735	Stop Ring
14	2	1885709	Safety Sleeve
15	1	1776034	Outer Protection
16	1	1877034	Inner Protection
17	1	1786711	Tube Bearing Inner Tube
18	1	90SS6034	Complete Protection
19	2	1006065	Anti-Rotation Chain
20	1	1140010	Outer Decal
21	1	1140011	Inner Decal
22	1	1140957B	User manual

11 LIMITED WARRANTY



GEARMORE, INC., warrants each new Gearmore product to be free from defects in material and workmanship for a period of twelve (12) months from date of purchase to the original purchaser. This warranty shall not apply to implements or parts that have been subject to misuse, negligence, accident, or that have been altered in any way.

Our obligation shall be limited to repairing or replacement of any part, provided that such part is returned within thirty (30) days from date of failure to Gearmore through the dealer from whom the purchase was made, transportation charges prepaid.

This warranty shall not be interpreted to render us liable for injury or damages of any kind or nature, direct, consequential or contingent, to person or property. This warranty does not extend to loss of crops, loss because of delay in harvesting or any other expenses, for any other reasons.

Gearmore in no way warrants engines, tires, or other trade accessories, since these items are warranted separately by these respective manufacturers.

Gearmore reserves the right to make improvements in design or changes in specification at any time, without incurring any obligations to owners or units previously sold.

GEARMORE, INC.
13477 Benson Ave.
Chino, CA 91710

Always refer to and heed machine operating warning decals on machine.

The serial number of this product is stored in our computer database, thus submitting a warranty registration card is not required.