

GEARMORE®

DUSTER

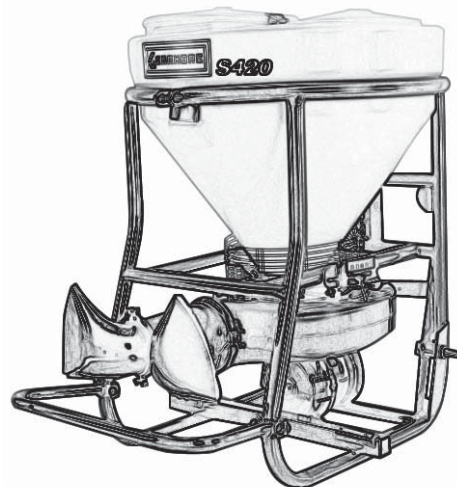

Operation, Service & Parts Manual For Models S420

June 2012

TABLE OF CONTENTS

<u>SECTION</u>	<u>DESCRIPTION</u>	<u>PAGE</u>
1	Introduction	1
1.1	Purchaser's Responsibility	1
1.2	Serial Number Information	1
2	Installation	2
2.1	Specifications	2
2.2	Duster Installation	2
3	Operation	3
3.1	Before Operating Duster	3
3.2	Operating Duster	3
4	Lubrication	4
4.1	Driveshaft	4
4.2	Gearbox	4
4.3	Agitator	4
4.4	Cleaning & Storage	4
5	Safety	5 - 6
5.1	Safety Tips	5
5.2	Safety Decals	6
5.3	Personal Safety	7
5.4	Lifting Duster	7
6	Diagram of Duster	8
7	Troubleshooting	9
8	Parts	10 - 19
8.1	Frame Assembly	10
8.2	Tank Assembly	11 - 13
8.3	Handle Assembly	14
8.4	Fan Assembly	15
8.5	Gearbox Assembly	16 - 17
8.6	Distributor Assembly	18
8.7	Driveline Assembly	19
9	Limited Warranty	20

1 INTRODUCTION

We welcome you as an owner of a Gearmore duster. Please read the following instructions and refer to them when required. This manual contains parts diagrams and replacement parts lists. Do not modify the equipment in any way. Unauthorized modification may impair the function and/or safety and could affect the life of the equipment.

Where replacement parts are necessary for periodic maintenance and servicing, genuine factory replacement parts ***MUST*** be used to restore your equipment to original specifications. The manufacturer will not be responsible for injuries or damages caused by use of unapproved parts and/or accessories.

The manufacturer reserves the right to make improvements to the machinery and parts at any time and at their discretion.

OPERATOR ORIENTATION - The directions left, right, front and rear, are as seen from the driver's seat and facing in the direction of travel.

1.1 PURCHASER'S RESPONSIBILITY

It is the responsibility of the owner to make sure the machine is maintained properly, and that all parts are in working order. It is the responsibility of the purchaser and/or operator to.....

- Inspect the equipment and replace or repair any parts that are damaged or worn which under continued operation would cause damage, wear to other parts, or cause a safety hazard.
- Return the equipment or parts to the authorized dealer, from where it was purchased, for service or replacement of defective parts that are covered by warranty. (The factory may inspect equipment or parts before warranty claims are honored.)
- Payment of all costs incurred by the dealer for traveling to or transporting the equipment for warranty inspection and/or claims.

1.2 MODEL / SERIAL NUMBER

NAME: _____

PURCHASED FROM: _____

DATE OF PURCHASE: _____

MODEL NUMBER: _____

SERIAL NUMBER: _____

2 INSTALLATION

2.1 DUSTER SPECIFICATIONS

APPLICATION RATES:	Adjustable from 12 to 80 pounds per acre.
HOPPER:	The tank is thick walled polyethylene. <i>(See Note)</i>
BLOWER:	Dynamically balanced steel fan in an aluminum housing.
DISTRIBUTORS:	Two completely adjustable 360° nozzles.

2.2 DUSTER INSTALLATION

The Duster should be mounted on a flat surface, always clear away all people not involved in the operation, including children and animals.

1. With tractor engine off and key out of the ignition, hook the tractors lower lift arms to the duster lower lift pins. (S420 comes with Cat. 1 pin as standard equipment.)
2. Remove tractor top link and install on duster.
3. Mount other side of top link back on the tractor.
4. **P.T.O. Installation:**

First, connect the P.T.O. shaft to the tractor. With the shaft in its shortest position, there should be about a 2" clearance between the end of the gearbox shaft and the end of the P.T.O. shaft. Should it be necessary to shorten the P.T.O. shaft, shorten both male and female shafts equally, keeping the protective tube covers 1" shorter than the steel tubes.

Particular attention should be given to carefully removing all burrs and to clean and lubricate the steel tubes and protective covers. There must be sufficient telescopic movement so that the two tubes do not touch the end of the P.T.O. shaft.

It is most important to carefully raise and lower the duster with the tractor hydraulic system, making sure that the P.T.O. shaft does not bottom or disengage the telescopic shaft tubes, otherwise damage may occur.

NOTE: Driveshaft angle should not exceed 15° when in operation.

3 OPERATION

3.1 BEFORE OPERATING YOUR DUSTER

1. Inspect for damage and loose or missing parts. Make sure all fittings and drive components are secure.
2. Lubrication: *See Lubrication Section.*
3. Check hopper for any foreign objects.

3.2 TO OPERATE DUSTER

1. Calculate the exact amount of sulfur needed for the treatment.
2. Carefully read the instructions for the manufacturer's use of the sulfur, check the conditions for use, the correct dosage and the expiration date.
3. Push flow adjusting lever away from the tractor, which is the closed position.
4. Fill hopper with material being used. (**Note: *Sulfur Powder Only***)
5. Due to the inconsistency of sulfur, it is almost impossible to set a true rate chart. For this reason, Gearmore can only recommend an average start rate at 1 ½ on control lever for 15 lbs. of sulfur per acre at 4 M.P.H. Adjust lever up or down from there.
6. Start engine and engage tractor P.T.O. at engine idle.
7. Pull lever toward the tractor, which increases the powder flow.
8. After locating the delivery position that meets your required application rate, disengage P.T.O. and turn tractor engine off. Set the adjustable gray handle so the operator can easily return to that position.
9. Restart engine and engage P.T.O., gradually increase engine R.P.M. and start dusting.

NOTE: Small gray plastic handle is only a "stop set", thus little locking pressure is required.

4 LUBRICATION

4.1 DRIVESHAFT

DRIVESHAFT: The driveshaft must be lubricated before the duster is put into use. After that, grease when needed. It is also necessary, from time to time, to untelescope the driveshaft to clean and re-grease tubing.

4.2 GEARBOX

GEARBOX: Check gearbox oil level through sight gauge with machine on flat ground. If oil level is low, lay machine on ground and add SAE 90 weight oil through filling plug (See Ref. A).

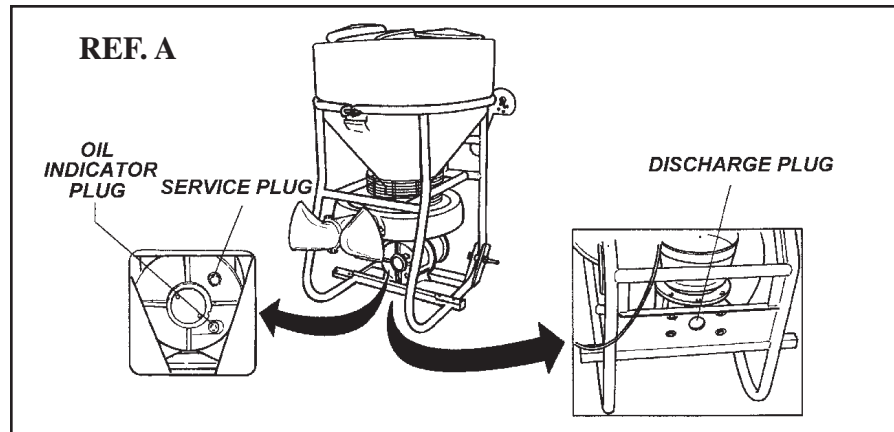

4.3 AGITATOR

AGITATOR: Under hopper and above blower is an extended grease zerk for lubricating agitator. Grease at the beginning of the season and **every 50 hours** of work (See Ref. B).

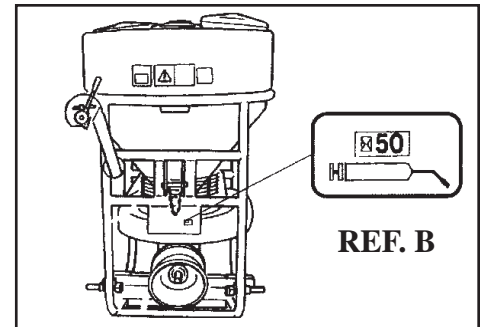

4.4 CLEANING & STORAGE

1. **Do Not** let sulfur build up on the blower fan. The best and easiest way to clean the fan is with "crushed walnut shells". This will insure that the blower operates to maximum efficiency and greatly reduces potential damage to the blower assembly.
2. Do not leave material in hopper for long periods of time.
3. Clean duster thoroughly before storing.
4. Check duster for needed repairs before time to dust again.
5. Always store machine where children and unskilled people can not get to it.

5 SAFETY

5.1 SAFETY TIPS

1. **NEVER** run PTO at speeds exceeding 540 R.P.M.
2. Duster should be operated only by qualified personnel.
3. **ALWAYS** fill duster slowly to avoid spillage.
4. When starting duster, maintain a safe distance from moving parts.
5. **NEVER** leave duster unattended while it is running.
6. Keep hands, feet and clothing away from moving parts.
7. Handle powders carefully. Follow manufacturer's directions for application and rates.



WARNING!!

OPERATING THE TRACTOR PTO AT OVER 540 R.P.M. OR APPLYING RATES OF LESS THAN 8 POUNDS OF SULFUR PER ACRE COULD CAUSE THE SULFUR TO MELT.

SAFETY WARNING! All of the preparation, use, maintenance, handling and transport operations should be carried out only after having acquired the perfect understanding of all instructions contained in this publication and the ability of interpreting the symbols applied on the machine in the correct way.

Safety Shields: Make sure all safety shields are secure before operating duster.

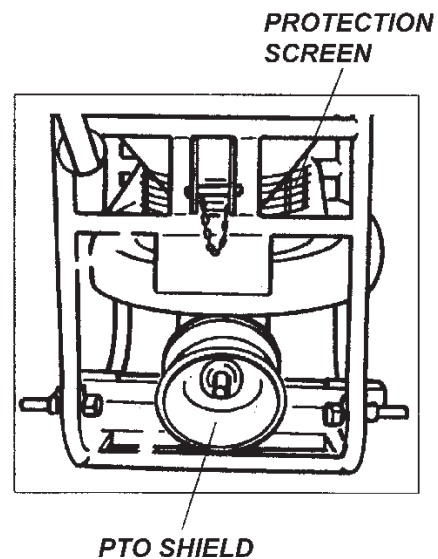

5.2 SAFETY DECALS

FRONT VIEW

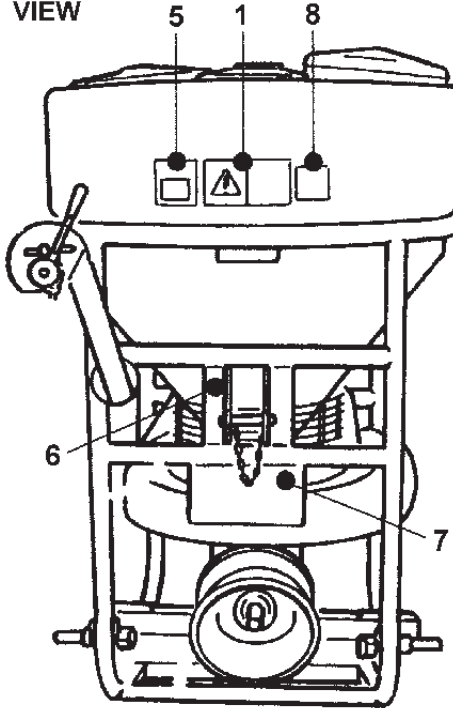

REAR VIEW

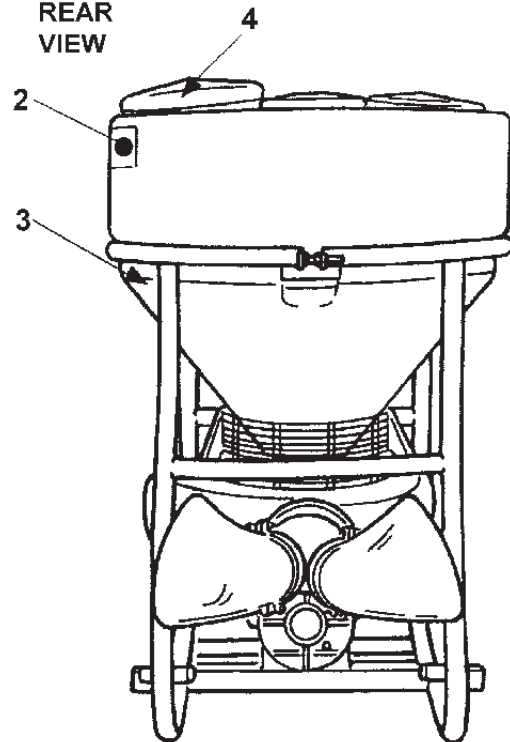

① 95001

1. Stop the engine and take the key out before doing maintenance or repairs to the duster.

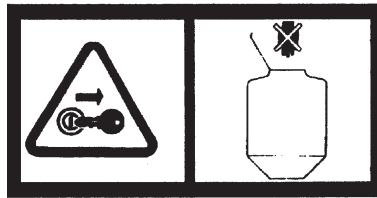

② 95011

2. **DANGER:** Rotating components. Before lifting the lid, stop the engine and remove key, then make sure all components have stopped before continuing.

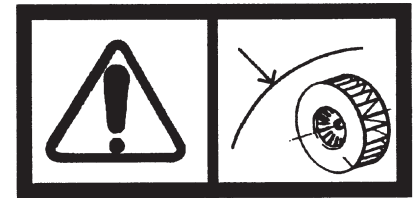

③ 95005

3. **DANGER:** Rotating components. Before removing shield, stop the engine and remove key. Make sure all components have stopped before continuing.



④ 95006

4. **ATTENTION:** Read the maintenance section of book before using or working on the machine.



⑤ 95010

5. **ATTENTION:** Maximum working speed of the tractor PTO must not exceed 540 R.P.M.



⑥ 95059

6. Hooking point for lifting the duster.

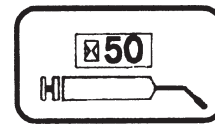

⑦ 95053

7. **ATTENTION:** Grease before the season and every 50 hours after.

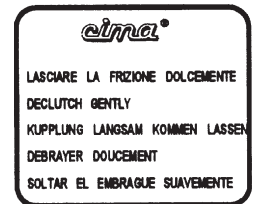

⑧ 95068

8. **ATTENTION:** Disengage the clutch gently. Fan start-up must be gradual.

5.3 PERSONAL SAFETY

PERSONAL SAFETY WEAR:

The toxicity of phytopharmaceuticals compels the people using them to wear adequately protective clothing and accessories to avoid the risks of contamination by contact or inhaling the sulfur.

THE OPERATORS MUST WEAR:

- A. Polyethylene or polyvinyl gloves.
- B. Complete overalls, in waterproof cotton, to guarantee transpiration, with side polypropylene coating. It is **IMPORTANT** to find disposable overalls with these materials so that after use they are disposed of in the same way as the toxic waste.
- C. Half-size masks in neoprene rubber with one or two filters. It is **IMPORTANT** to use filters designed for gas or organic vapors combined with filters against powder for mists and irritating powders or for mists of harmful or toxic powders.

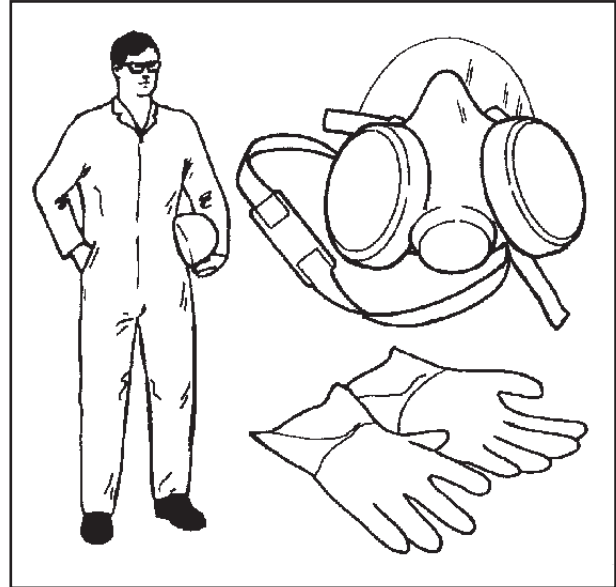

5.4 LIFTING DUSTER



Remove the head before lifting the duster.

All operations should be carried out with the tank completely empty.

1. Check that the cables or the chains are sufficient enough for the weight to be lifted.
2. Hook the machine in the supporting point indicated on the frame by the decal and check the tightening of all of the parts involved in the operation.
3. Lift the machine, placing it on the means of transport, which must be perfectly stable.
4. During the transport, the machine should be tied and fastened to the means of transport by an appropriate harness.

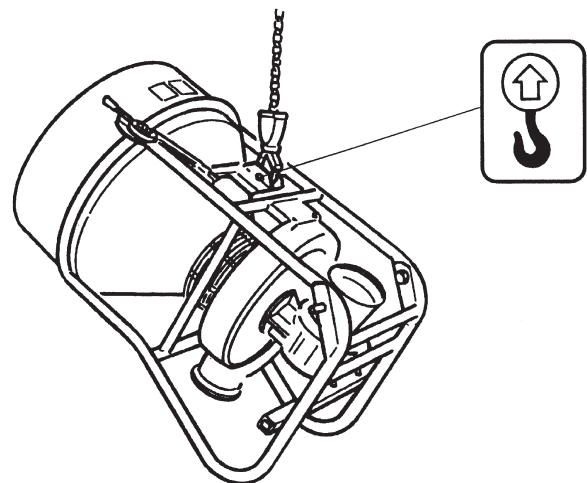

6 DIAGRAM OF DUSTER

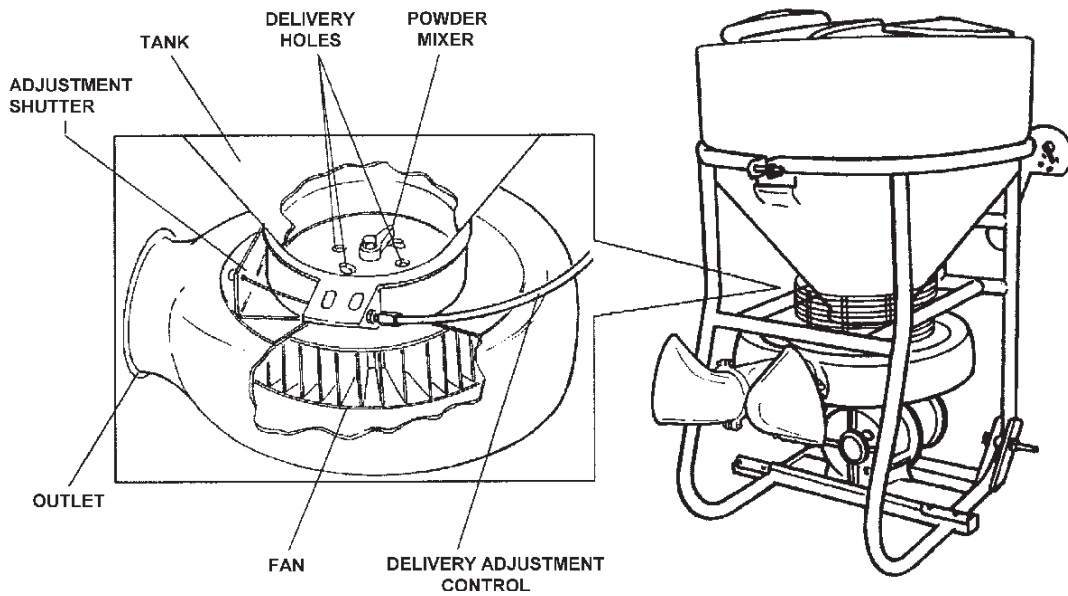
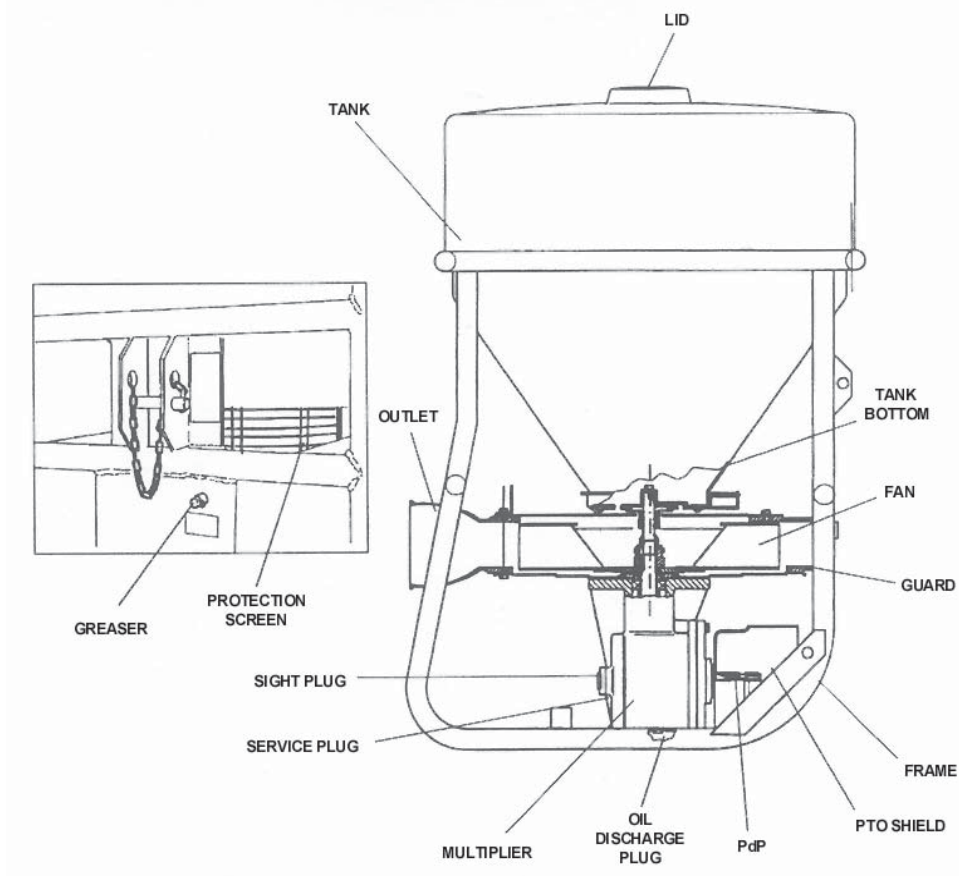

7 TROUBLESHOOTING

PROBLEM	CAUSE	SOLUTION
Oil leakage	The input shaft seal is defective	Replace input shaft seal
	The gasket on the gearbox cover is defective	Replace gearbox cover gasket
Vibration in fan	The fan is caked with sulfur	Clean sulfur build-up off
	The fan is out of balance	Check fan blades, if damaged or broken, replace fan
Continuous noise	Bearings in gearbox dry or damaged	Check bearings in gearbox, if bad or damaged, replace
Sulfur not being delivered	The feeding holes on the tank bottom are clogged	Clean the bottom feeding holes
	Bottom of tank caked with sulfur	Clean caked sulfur off the tank bottom
Sulfur delivery not uniform	Nozzles caked with sulfur	Clean caked sulfur off nozzles
	Nozzle end damaged or bent	Open damaged or bent nozzle back up

8 PARTS

8.1 FRAME ASSEMBLY

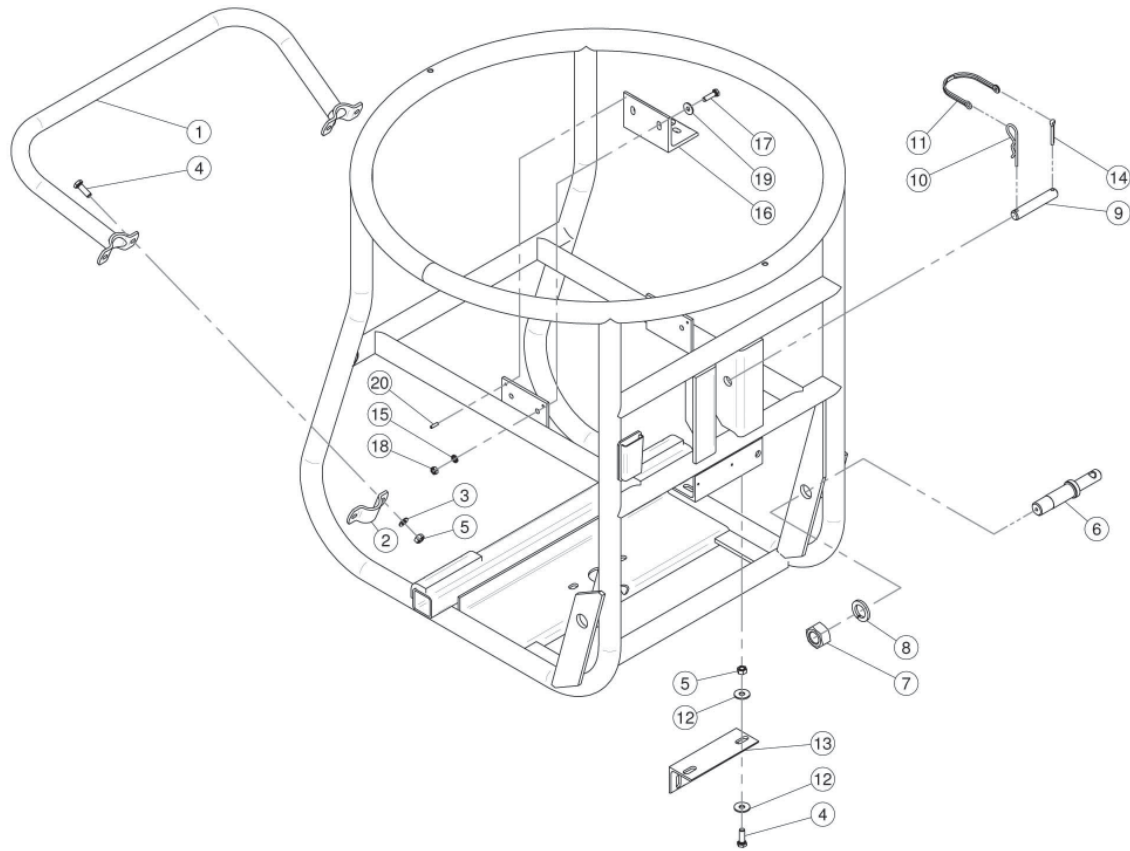

<u>REF #</u>	<u>QTY.</u>	<u>PART NO.</u>	<u>DESCRIPTION</u>
1	1	S0.483.000	Bumper
2	2	S0.493.000	Shaped Plate Fixing
3	4	RP.010.000	Washer D.10
4	6	TE.010.030T	Screw TE M10 x 30
5	6	D0.10.5587G	Nut M10
6	2	S0.481.000	Pin Power Lift
7	2	D0.27.5587G	Nut M27
8	2	RE.027.000	Washer D.27
9	1	04.076.000	Pin
10	1	00.100.004	Split Pin D.4
11	1	21.183.000	Cap Stop
12	4	RP.010.030	Washer D.10 x 30 mm
13	1	S0.527.000	Fixing Fan Housing Plate
14	1	CP.006.040I	Pin D.6 Lg.40
15	4	RD.008.000	Tab Washer D.8
16	2	S0.542.000	Angular of Fixing
17	4	TE.008.030T	Screw TE M8 x 30
18	4	D0.08.5588G	Nut M8
19	4	RP.008.024	Washer D.8 x 24
20	4	SE.005.020	Pin 5 x 20 - UNI 6874

8.2 TANK ASSEMBLY

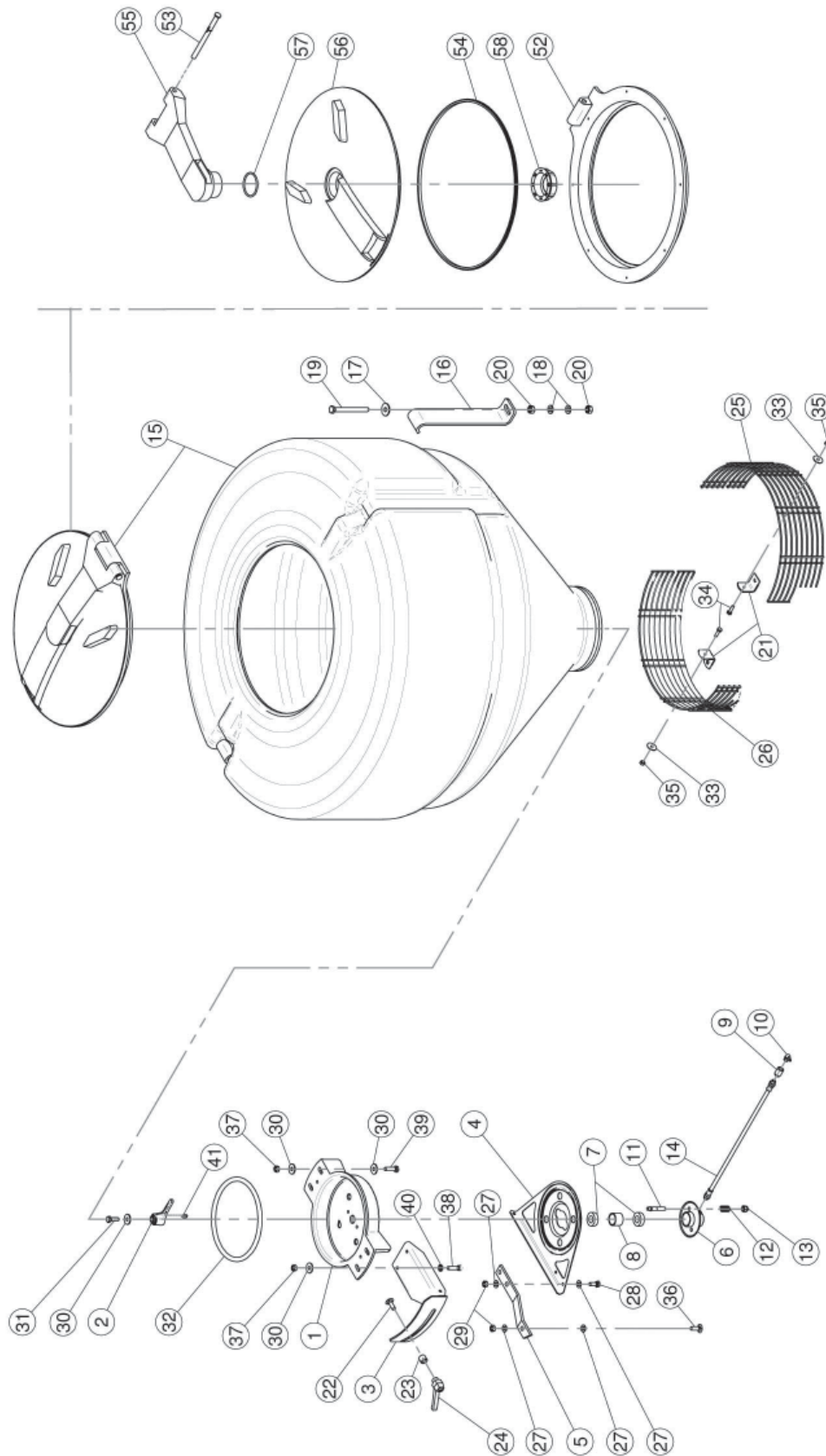

8.2 TANK ASSEMBLY (continued)

<u>REF #</u>	<u>QTY.</u>	<u>PART NO.</u>	<u>DESCRIPTION</u>
1	1	S0.475.000	Fixing Closing Support
2	1	S0.076.001	Powder Agitator
3	1	S0.524.000	Bracket
4	1	S0.476.000	Lock Gate
5	1	S0.523.000	Indicator Level
6	1	S0.219.010	Dust Seal
7	2	S0.217.000	Gasket
8	1	S0.525.000	Spacer
9	1	02.737.000	Accessori
10	1	IS.010.001	Greaser
11	2	S0.083.000	Pin
12	2	S0.211.000	Spring
13	2	DA.008.0AG	Self Locking Nut M8
14	1	02.738.040	Greaser Extension M10 x 1 L=400
15	1	S0.496.100C	L200 Complete Tank
16	2	S0.510.000	Fixing Tank Bracket
17	2	RP.010.030	Washer D.10 x 30 mm
18	4	RP.010.000	Washer D.10
19	2	TE.010.100T	Screw TE M10 x 100
20	4	D0.10.5587G	Nut M10
21	2	S0.489.000	Bracket for Wire Gauze
22	1	02.496.000	M8 x 25 Bolt
23	1	S0.508.000	Adjustment Lock Bush
24	1	S0.216.000	Fixing Handle
25	1	S0.488.100	Protection Wire Gauze
26	1	S0.488.000	Protection Wire Gauze
27	6	RP.008.000	Washer D.8
28	2	TE.008.020T	Screw TE 8 x 20
29	2	D0.08.5588G	Nut M8
30	7	RP.008.024	Washer D.8 x 24
31	1	TE.008.025T	Screw TE M8 x 25
32	1	S0.492.000	Sponge Ring
33	2	RP.006.024	Large Washer Ø 6
34	2	TE.006.020T	Screw TE M6 x 20
35	2	D0.06.5588G	Nut M6
36	1	02.496.010	M8 x 25 Bolt
37	5	D0.08.5587G	Nut M8
38	2	TCE.008.030	Bolt TCE M8 x 30
39	2	TE.008.030T	Screw TE M8 x 30
40	2	RD.008.000	Tab Washer D.8
41	1	L.06.06.12	Key 6 x 6 x 12

8.2 TANK ASSEMBLY (continued)

02.405.100 LID ASSEMBLY

<u>REF #</u>	<u>QTY.</u>	<u>PART NO.</u>	<u>DESCRIPTION</u>
52	1	002.405.000.B	Base Ring
53	1	20.787.000.D	Pin
54	1	02.405.002	Shaped Gasket
55	1	02.405.001	Arm
56	1	02.405.000.A	Gripping Plate
57	1	OR.000.512	51 x 3.5 O-Ring Gasket
58	1	02.405.100.I	Stop for Ribaltabile Lid

8.3 HANDLE ASSEMBLY

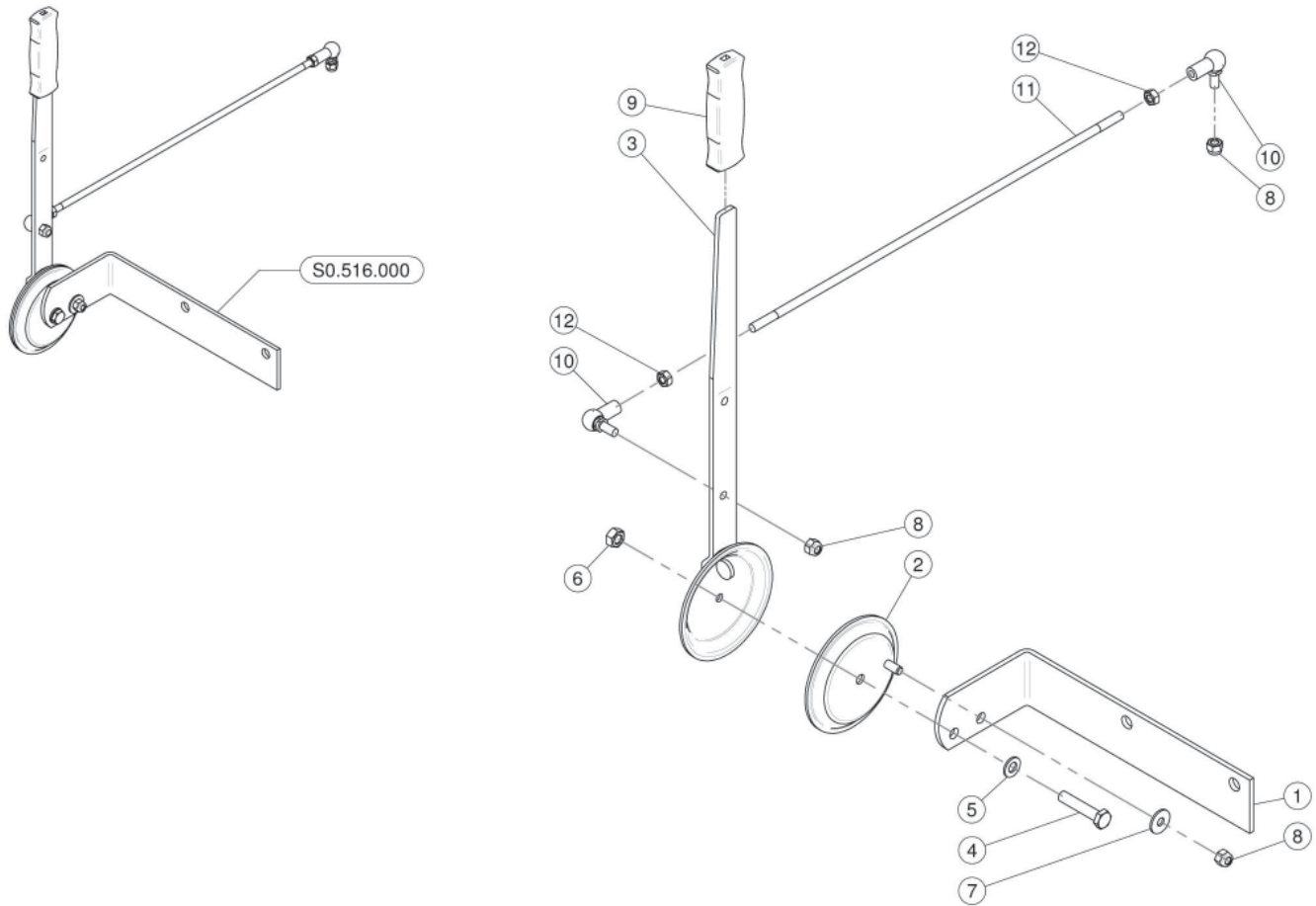

<u>REF #</u>	<u>QTY.</u>	<u>PART NO.</u>	<u>DESCRIPTION</u>
1	1	S0.517.000	Handle Fixing Regulation Set
2	1	S0.214.004	Fixed Particular for Handle
3	1	S0.214.001	Mobile Particular for Handle
4	1	TE.010.050T	Screw M10 - 50
5	1	RP.010.000	Washer D.10
6	1	D0.10.5588G	M10 6S Big Lead Nut 5588
7	1	RP.008.024	Washer D.8 x 24
8	3	DA.008.0AG`	Self Locking Nut M8
9	1	S0.215.000	Handle
10	2	S0.212.000	Supple for Handle
11	1	S0.521.000	Tightener D.8 L=480
12	2	D0.08.5588G	Nut M8

8.4 FAN ASSEMBLY

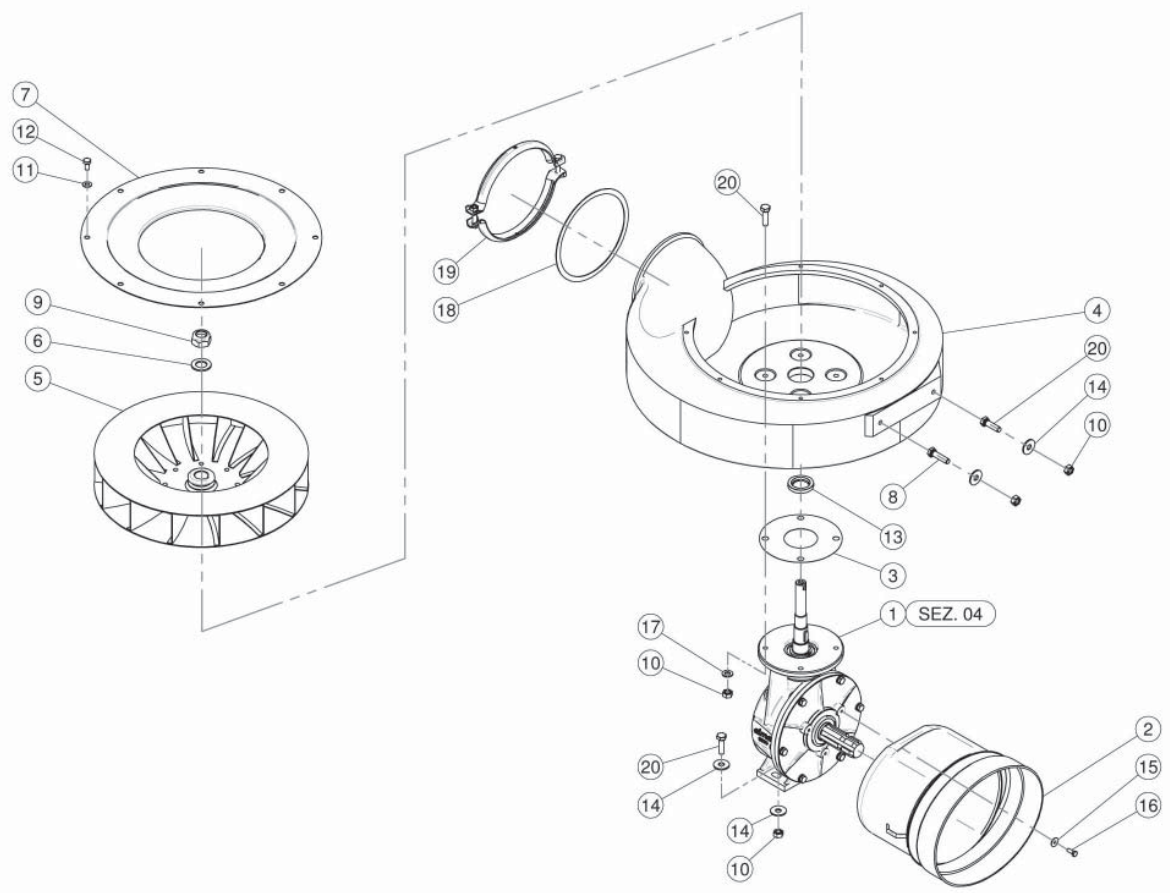

<u>REF #</u>	<u>QTY.</u>	<u>PART NO.</u>	<u>DESCRIPTION</u>
1	1	S0.350.000	Complete Gearbox R10/58
2	1	02.442.000	Shaft Cone 280 x 230 L=230
3	1	S0.332.005	Gasket
4	1	S0.201.000	Fan Housing
5	1	S0.202.000	Fan
6	1	RP.022.000	Washer D.22
7	1	S0.203.000	Suction Cover
8	1	TE.010.040T	Screw TE M10 x 40
9	1	DA.022.0BF.20	Nut M22
10	8	D0.10.5587G	Nut M10
11	8	RP.008.000	Washer D.8
12	8	TE.008.016T	Screw TE M8 x 16
13	1	BASL.30.47.07	Sealing Ring 30 x 47 x 7
14	6	RP.010.030	Washer D.10 x 30 mm
15	3	RP.006.018	Washer D.6 x 18
16	3	TE.006.016T	Screw TE M6 x 16
17	4	RP.010.000	Washer D.10
18	1	40.225.000G	Gasket
19	1	05.616.000	Pipe Clamp D.175
20	7	TE.010.035T	Screw TE 10 x 35

8.5 GEARBOX ASSEMBLY

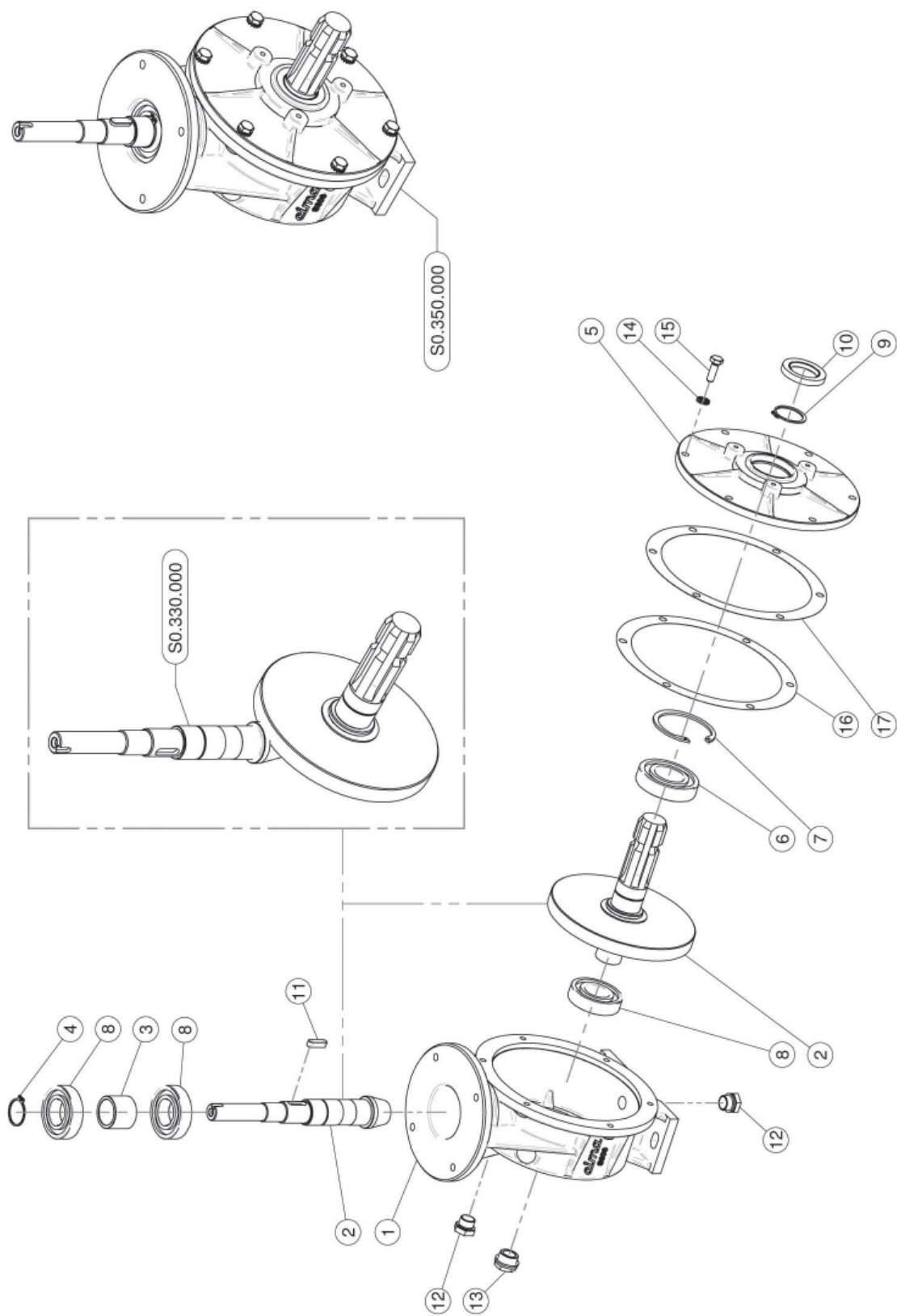

8.5 GEARBOX ASSEMBLY (continued)

<u>REF #</u>	<u>QTY.</u>	<u>PART NO.</u>	<u>DESCRIPTION</u>
1	1	S0.306.000	Gearbox Body
2	1	S0.330.000	Pinion and Crown Wheel
3	1	S0.305.000	Spacer
4	1	E0.030.000	Circlip D.30
5	1	S0.307.000	Gearbox Plate
6	1	K6.207.000	Bearing
7	1	I0.072.000	Spacing Bar
8	3	K6.206.000	Bearing
9	1	E0.035.000	External D.35 Circlip
10	1	BASL.35.52.07	Oil Seal
11	1	L.08.07.25	Key 8 x 7 x 25
12	2	TM.038.000	Packing
13	1	S0.087.012	Oil Level Indicator
14	6	RD.008.000	Tab Washer D.8
15	6	TE.008.025T	Screw TE M8 x 25
16	1	S0.320.002	Gasket
17	1	S0.320.003	Gasket

8.6 DISTRIBUTOR ASSEMBLY

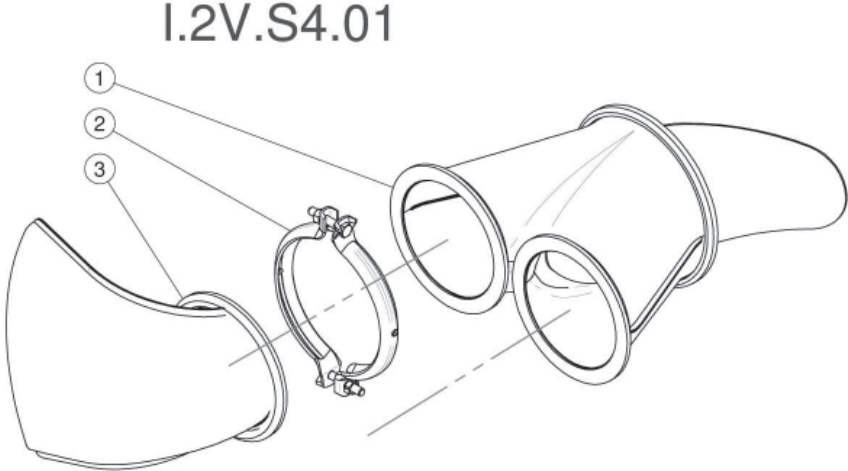
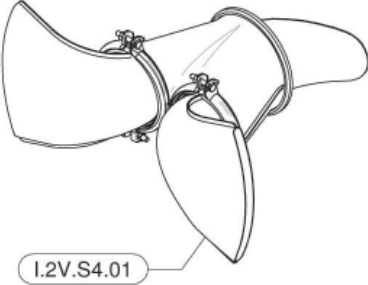

<u>REF #</u>	<u>QTY.</u>	<u>PART NO.</u>	<u>DESCRIPTION</u>
1	1	S0.204.000	Body Head
2	2	04.027.000	Pipe Clamp D.130
3	2	S0.205.100	Nozzle Metal Elbow

8.7 DRIVELINE ASSEMBLY 710456FFT077

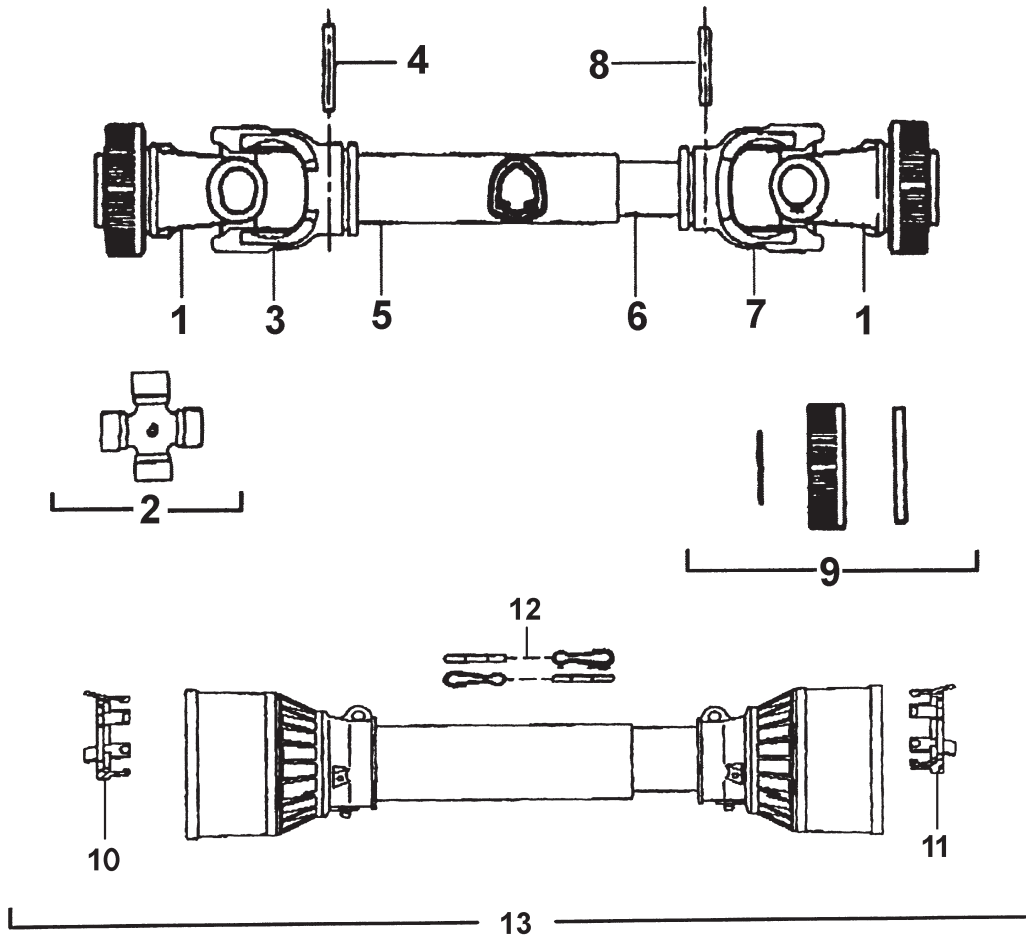

<u>REF #</u>	<u>QTY.</u>	<u>PART NO.</u>	<u>DESCRIPTION</u>
1	2	572040351	RS Collar Yoke 1- $\frac{3}{8}$, 6-Spline
2	2	41204	Cross Kit Assembly #4
3	1	204046851	Outer Tube Yoke
4	1	341038000	Roll Pin O.T.
5	1	225120860	Outer Drive Tube
6	1	225100860	Inner Drive Tube
7	1	204046852	Inner Tube Yoke
8	1	341048000	Roll Pin I. T.
9	2	240002451	RS Collar Kit
10	1	255040005	Shield Bearing Outer
11	1	255040006	Shield Bearing Inner
12	2	252000001	Safety Chain
13	1	5F04086F6	Complete Shield w/Bearings

9 LIMITED WARRANTY



GEARMORE, INC., warrants each new Gearmore product to be free from defects in material and workmanship for a period of twelve (12) months from date of purchase to the original purchaser. This warranty shall not apply to implements or parts that have been subject to misuse, negligence, accident, or that have been altered in any way.

Our obligation shall be limited to repairing or replacement of any part, provided that such part is returned within thirty (30) days from date of failure to Gearmore through the dealer from whom the purchase was made, transportation charges prepaid.

This warranty shall not be interpreted to render us liable for injury or damages of any kind or nature, direct, consequential or contingent, to person or property. This warranty does not extend to loss of crops, loss because of delay in harvesting or any other expenses, for any other reasons.

Gearmore in no way warrants engines, tires, or other trade accessories, since these items are warranted separately by these respective manufacturers.

Gearmore reserves the right to make improvements in design or changes in specification at any time, without incurring any obligations to owners or units previously sold.

GEARMORE, INC.
13477 Benson Ave.
Chino, CA 91710

Always refer to and heed machine operating warning decals on machine.

The serial number of this product is stored in our computer database, thus submitting a warranty registration card is not required.