



# **ROTARY MOWER**

**OPERATION, SERVICE  
& PARTS MANUAL FOR**

**L-G-40-40-P, L-G-48-40-P,  
L-G-60-40-P & L-G-72-40-P**

**Slip Clutch Models:**

**L-G-60-40-SC-P & L-G-72-40-SC-P**

**February 2003**

# TABLE OF CONTENTS

Introduction .....	1
Set-up Instructions .....	2
Preparation & Training .....	3
Operational Safety .....	4-5
Maintenance Safety .....	6
Mower Safety Decals .....	7
General Maintenance .....	8
Troubleshooting .....	9
Mower Assembly .....	10-11
Gearbox Assembly .....	12-15
Stump Jumper Assembly .....	16
Driveline .....	17-18
Limited Warranty .....	19

Date of Purchase: \_\_\_\_\_

Model Number: \_\_\_\_\_

Serial Number \_\_\_\_\_

# INTRODUCTION

*We welcome you as an owner of a Gearmore mower. Please read the following instructions and refer to them when required:*

## BEFORE OPERATING YOUR MOWER

1. Inspect for damage and loose or missing parts. Make sure all fittings and drive components are secure.
2. Lubrication (*See Lubrication Section*).
3. Remove all large, foreign objects from area being mowed.

## TO OPERATE MOWER

1. Connect mower to the tractor 3-point hitch lower link arms. (Make sure tractor and mower are on a level surface.)
2. Connect top link of tractor to mower and adjust turnbuckle so the mower is level with the ground.
3. Install driveshaft after making sure it is the correct length. (See separate warning sheet on the correct method of achieving the proper driveshaft length.)
4. Set height of tailwheel based on what height you want to cut. Example: The blades are set 1" above the skids. Thus, if you want a 2" cut, you would set tailwheel so skids are 1" above ground.

**NOTE:** *The mower is designed to float on the tailwheel and mower 3-point hitch, so the mower should not be dragged on the ground.*

5. Set height stops on the tractor 3-point lift so mower will not be raised higher than necessary. Failure to do this could cause damage by putting excessive angle on the driveshaft.
6. Engage the tractor PTO when tractor engine is at idle speed. Engaging the PTO with engine at full speed will reduce the life of the driveshaft. For most cutting operations, a ground speed of 3 to 5 MPH and PTO at full 540 RPM is recommended.

# SET-UP INSTRUCTIONS

1. Bolt the flat plates (ref. #1) to inside of deck ears (single notch side down).
2. Mount the a-frame (ref. #2) to the outside of flat plates (ref. #1) using Cat. I pins supplied (ref. #3). (Do not tighten at this time)
3. Remove tailwheel a-frame (ref. #4) bolts and mount the lift arm braces (ref. #5) using existing bolts. (Do not tighten at this time)
4. Bend lift arm braces (ref. #5) towards a-frame (ref. #2) and bolt lift arm braces to outside of a-frame and floating top link (ref. #6) to a-frame.
5. Tighten all bolts that you have loosened and installed. By using an impact air gun, (ref. #5) lift arm braces will fit into position.
6. Install driveline onto gearbox input shaft using bolt and retaining clip supplied. Check for proper PTO shaft length.

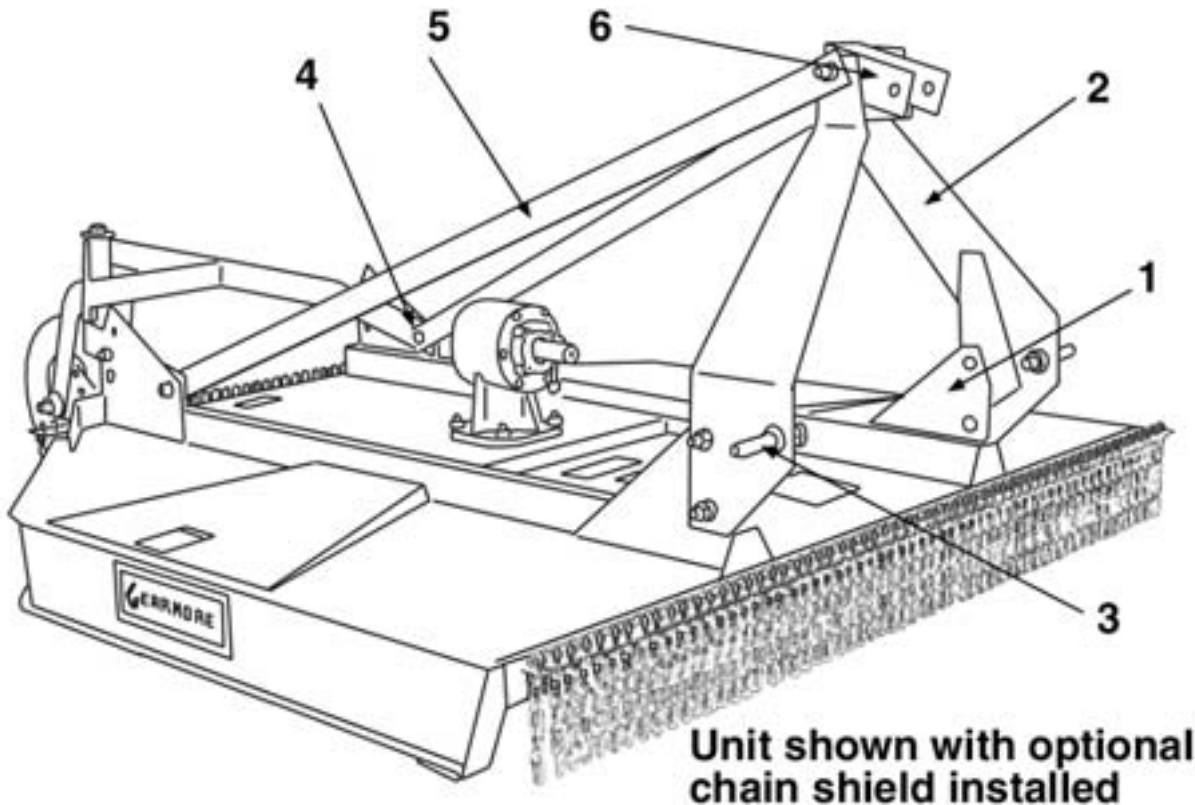

**Unit shown with optional  
chain shield installed**

# PREPARATION



**READ THIS BEFORE OPERATING MOWER**



## TRAINING

Know your controls and how to stop tractor engine and mower quickly in an emergency. ***READ THIS OPERATOR'S MANUAL AND THE MANUAL PROVIDED WITH YOUR TRACTOR.***

To avoid accident or injury, ***do not*** allow anyone to operate this equipment without proper instructions. Any person who operates this equipment must be instructed in and be capable of the safe operation of the unit, its attachments and all controls.

***DO NOT*** allow children to operate machine, or adults to operate it without proper instructions.

## BEFORE OPERATION

- Always*** wear relatively tight and belted clothing when operating mower. Loose clothing should not be worn, as it could get caught in the moving parts or controls. Wear sturdy, rough-soled work shoes and protective equipment for eyes, hands, hearing and head. ***Never*** operate tractor or implements in bare feet, sandals or sneakers.
- Never*** permit any person other than the operator to ride on board the tractor at any time. ***DO NOT*** allow riders on mower at any time.
- Clear area of stones, branches or other debris that might be thrown, causing injury or damage.
- Operate only in daylight or good artificial light.
- Ensure mower is properly mounted, adjusted and in good operating condition.
- Ensure all PTO and other safety shielding is properly installed and in good condition.

# OPERATIONAL SAFETY

- ❑ Guards and safety shields are for *your* protection. **DO NOT** operate equipment unless they are in place.
- ❑ Read and observe **all safety decals** on the tractor and mower (see page7).
- ❑ **Always** operate tractor PTO (power take-off) at recommended RPM (revolutions per minute).
- ❑ Stay away from PTO shaft and mower when engaging PTO.
- ❑ Disengage tractor PTO and shift into neutral before attempting to start engine.
- ❑ **NEVER** allow anyone within 25' of machine while it is in operation.
- ❑ **DO NOT** stop or start suddenly when going uphill or downhill. Avoid operation on steep slopes.
- ❑ Be alert for holes in terrain and other hidden hazards. **Always** drive slowly over rough ground.
- ❑ Reduce speed on slopes and in sharp turns to prevent tipping or loss of control. Be careful when changing direction on slopes.
- ❑ Stop mower and tractor immediately upon striking an obstruction. Turn off engine, inspect mower and repair any damage before resuming operation.
- ❑ Disengage power to mower and stop engine before dismounting from tractor, before making any repairs or adjustments, transporting, or unclogging mower.
- ❑ Take all possible precautions when leaving tractor unattended. Disengage PTO, lower mower, shift into neutral, set parking brake, stop engine and remove key from ignition.

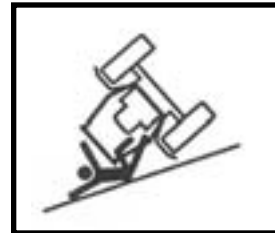

# OPERATIONAL SAFETY

Continued...

- ❑ Front tractor weights or front tire ballast should be used to enhance front end stability on small tractors.

- ❑ **NEVER** operate mower in raised position.

- ❑ Check to make sure PTO is properly connected and that the driveline is correct to prevent bottoming out or pulling apart during the full lift range of the hitch.



- ❑ This implement is designed for a one-man operation. It is the responsibility of the tractor operator to see that no one is in the proximity of the implement when it is started. **DO NOT** operate the implement when another person is within 25' of the implement.

- ❑ **NEVER** put hands or feet under mower deck while tractor engine or mower is running.



# MAINTENANCE SAFETY

- ❑ Support the mower with safety stands or blocks before working beneath it.
- ❑ Follow good shop practices:

**A.** Keep service area clean and dry.



**B.** Be sure electrical outlets and tools are properly grounded.

**C.** Use adequate light for the job at hand.



- ❑ Use only tools, jacks and hoists of sufficient capacity for the job.
- ❑ **NEVER** work on the mower unless the tractor engine is off and the driveline is disconnected.
- ❑ **ALWAYS** wear heavy canvas or leather gloves when handling mower blades.
- ❑ **NEVER** wear loose or frayed clothing when working on moving parts. (i.e. gearbox, blade pan, driveline, etc.)
- ❑ Make sure all guards are in place and properly secured when all maintenance work is completed.



# MOWER SAFETY DECALS

1. Keep all safety decals and signs clean and legible at all times.
2. Replace safety decals and signs that are missing or have become illegible. (Contact Gearmore at 909.548.4848 for *free* replacement safety decals.)

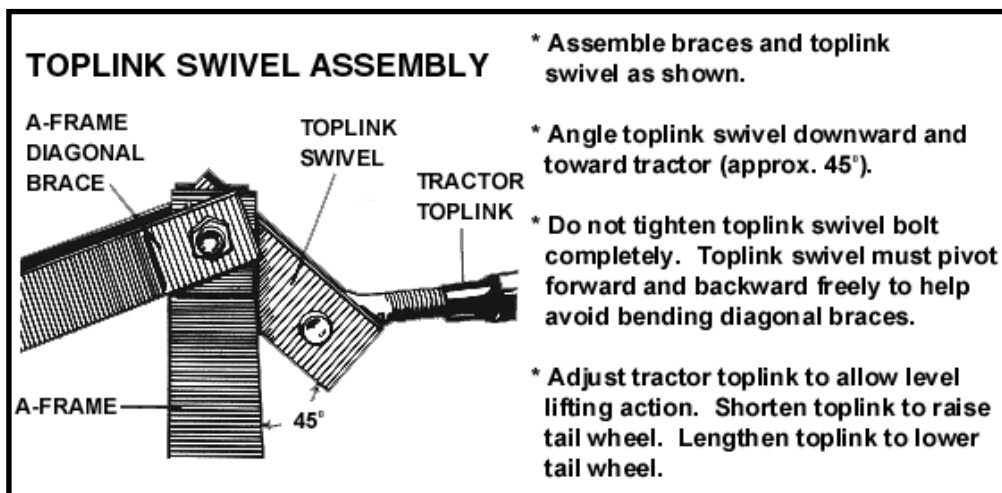

# GENERAL MAINTENANCE

Carefully follow all instructions as stated in this manual. This includes operation, lubrication, safety and maintenance. This mower was designed and built for years of reliable service if properly cared for. However, rotary mowers are a high RPM machine, thus daily attention is required.

- ✓ Check all bolts for tightness.
- ✓ Check to make sure all safety guards are in place.
- ✓ Check to remove any trash build-up.
- ✓ Check lubrication - *see lubrication section.*
- ✓ Check blades to make sure they are securely fastened.

## SERVICING BLADES

When replacing or grinding blades, both blades must be replaced or re-ground at the same time to maintain the proper balance in the mower. Gearmore mowers are equipped with special heat-treated alloy steel blades. Use only Gearmore blades, substitutes may be dangerous. **NEVER** try to straighten or weld blades.

## LUBRICATION

**DRIVESHAFT** - The driveshaft must be lubricated before mower is put into use. After that, grease every **8 hours** of use or when required. It is also necessary, from time to time, to untelescope the driveshaft to clean and re-grease tubing.

**GEARBOX** - Check gearbox oil level through square headed screw plug. Add SAE 90 weight oil when required. Change gearbox oil after every **400 hours** of use.

**TAILWHEEL** - Grease every **8 hours** of use or when required.

**TAILWHEEL PIVOT TUBE** - Grease *weekly* or when required.

To comply with OSHA AG Guarding Standard #1928.27, the following guards and shields **must** be kept in place and in good working condition:

1. Safety chain shielding
2. Driveshaft shields
3. Guards over moving parts

**BE CAREFUL AND ALWAYS THINK SAFETY FIRST!**

# TROUBLESHOOTING

PROBLEM	CAUSE	SOLUTION
Excessive vibration	Blades are not free to swing.	Check bushings and movements of blades.
	Blades are out of balance.	Check blades for damage or replace.
Unusual noise	Loose blade bolts or worn bushings.	Tighten blade bolts, check bushings for wear and change as needed.
	Bent blade carrier, blades striking deck.	Replace blade carrier.
	Deck bent causing blades to hit.	Straighten deck.
	Gearbox low of oil.	Check seals in gearbox and fill to proper level.
Poor cutting	Not maintaining proper PTO speed.	Check PTO with tachometer and operate at proper RPM.
	Improperly adjusted.	Adjust according to Operators Manual.
	Forward speed too fast.	Coordinate forward speed with blade speed.
	Dull blades.	Sharpen blades.
PTO turns and blades do not	Gears stripped in gearbox.	Replace or repair gearbox.
	Shear bolt sheared.	Replace shear bolt.
PTO will not telescope	Improper lubrication.	Separate and fill female tube half full of grease.
	PTO twisted.	Replace twisted portion.
	Bent PTO.	PTO too long. Size to tractor according to manual.
	Shields damaged.	Replace.
PTO twisted	Over torqued.	Caution operator not to ground out machine.
	Not maintaining correct PTO speed.	Maintain proper PTO speed.
Machine streaking	Cutting too high, leaving wheel tracks.	Cut lower and slow forward speed down.
	Not maintaining proper RPM speed.	Maintain proper RPM speed.

# MOWER ASSEMBLY

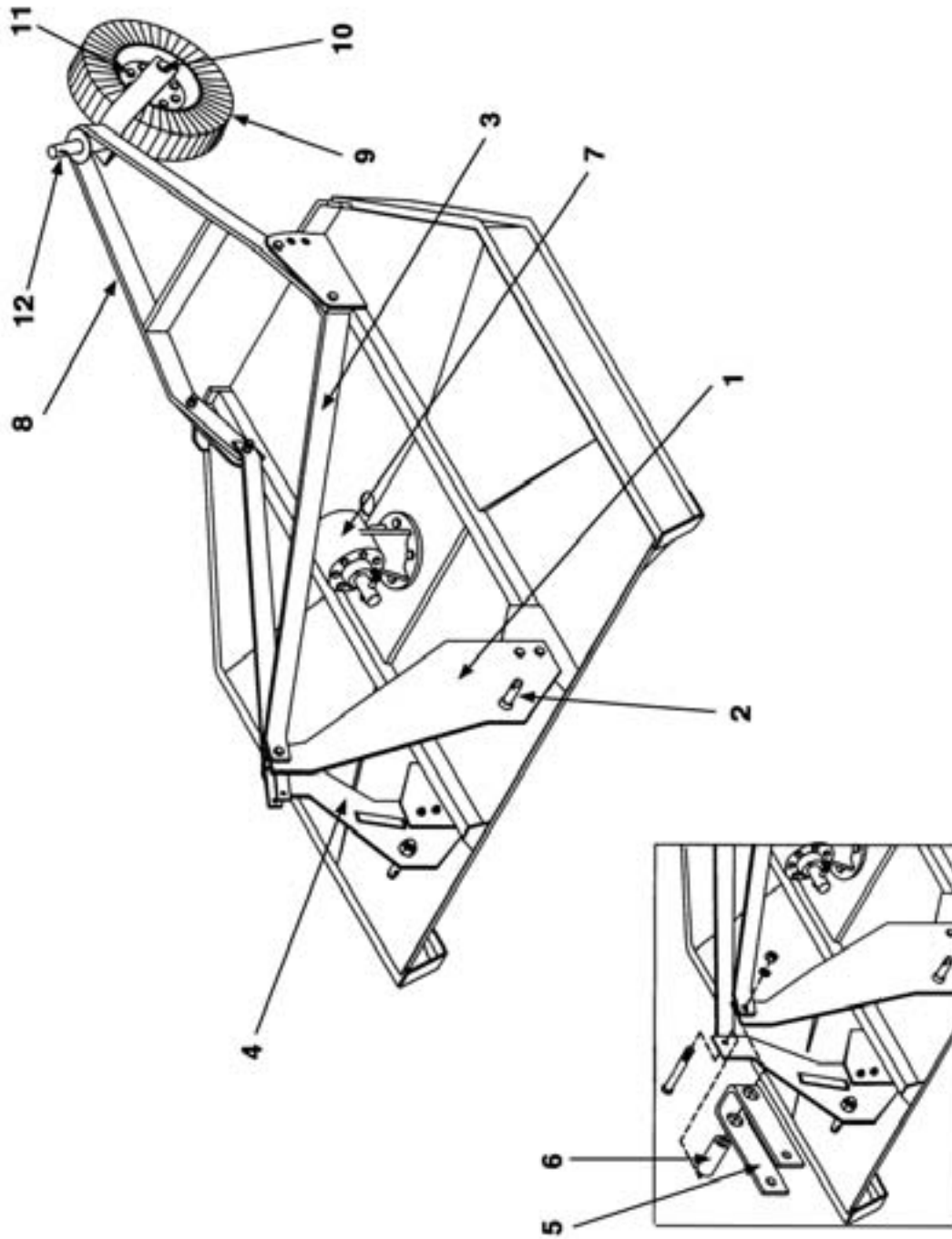

# MOWER ASSEMBLY

<u>REF#</u>	<u>QTY.</u>	<u>PART NO.</u>	<u>DESCRIPTION</u>
1	1	403391	Lift Arm L.H.
2	1	500001	Lift Pin Cat. I (2 pack)
3	2	360241	Lift Arm Brace L-40-48
3	2	360231	Lift Arm Brace L-60
3	2	360243	Lift Arm Brace L-72
4	1	403390	Lift Arm R.H.
5	1	360299	Top Swivel Assembly
6	1	311028	Bushing Swivel
7	1	184005	Gearbox Shear Pin
7	1	184010	Gearbox Slip Clutch
8	1	401025	A-Frame, Tailwheel
9	1	168001	Tire & Rim
10	1	501280	Axle Bolt Assembly
11	1	191100	Hub Assembly (less axle)
12	1	403019	Tailwheel Fork
13	1	147042	Shear Pin Driveline L-60/L-72
13	1	147029	Shear Pin Driveline L-40/L-48
13	1	147142	Slip Clutch Driveline

# SHEAR PIN GEARBOX ASSEMBLY

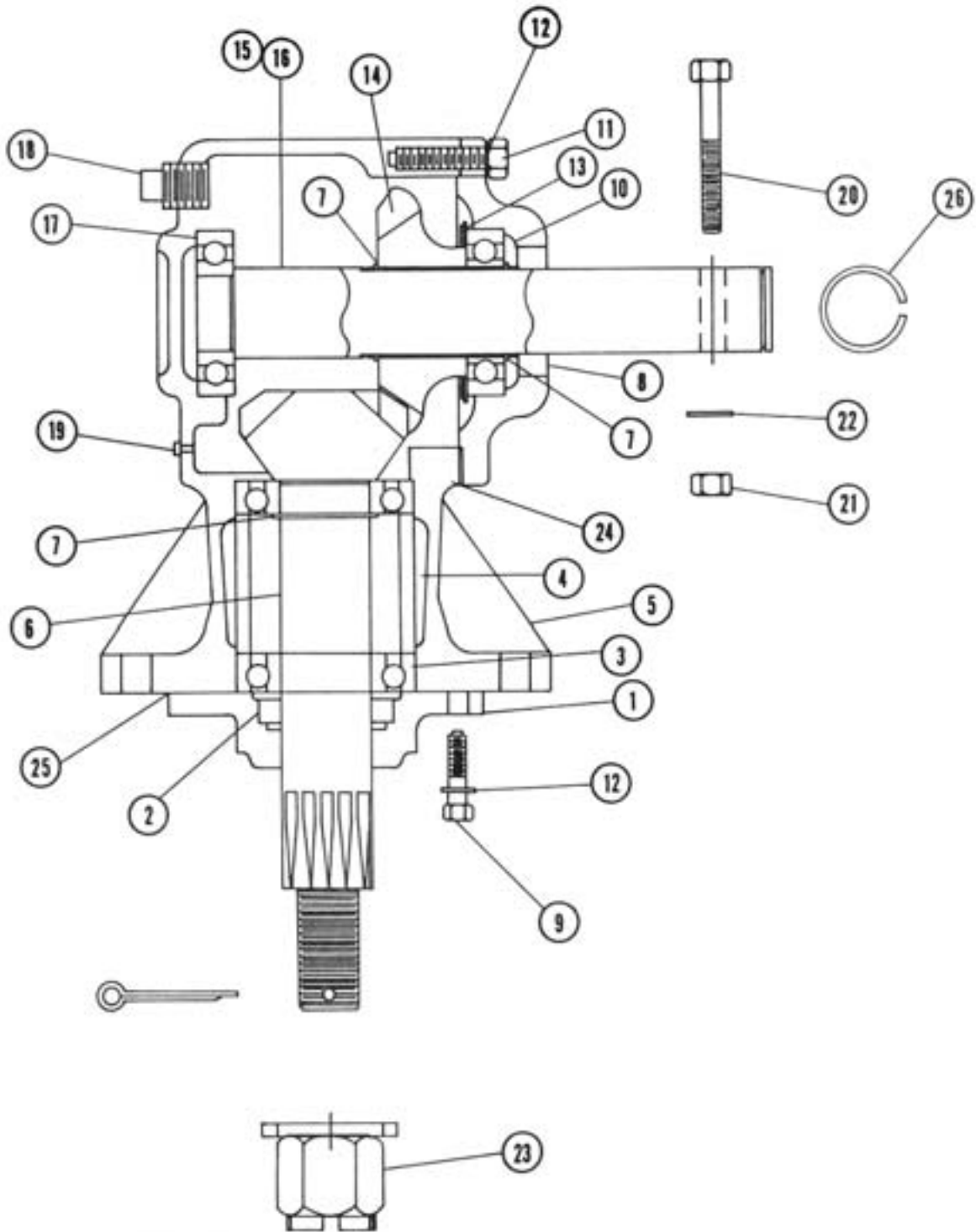

# SHEAR PIN GEARBOX ASSEMBLY

<u>REF#</u>	<u>QTY.</u>	<u>PART NO.</u>	<u>DESCRIPTION</u>
1	1	129005	Retainer
2	1	40X54X7	Oil Seal
3	3	6208	Bearing
4	1	131045	Spacer
5	1	129010	Housing
6	1	185006	Pinion
7	3	131031	Retainer Ring
8	1	35X54X10	Oil Seal
9	4	101117	Bolt 3/8" x 1-1/4"
10	1	129015	Cover
11	6	101112	Bolt 3/8" x 1"
12	10	103110	Lockwasher 3/8"
13	1	131030	Retainer Ring
14	1	185010	Gear 22T
15	1	186010	Input Shaft
16	1	106138	Snap Ring
17	1	6207	Bearing
18	1	131035	Plug 1/2" - 14NPT
19	1	131040	Plug 1/8" - 27NPT
20	1	500101	Shear Bolt 1/2"x3-1/2" Gr. 2 (5 pk.)
21	1	102010	Nut 1/2"
22	1	103010	Lockwasher 1/2"
23	1	501110	Castle Nut 1"
24	1	124130	Gasket
25	1	124131	Gasket

# SLIP CLUTCH GEARBOX ASSEMBLY

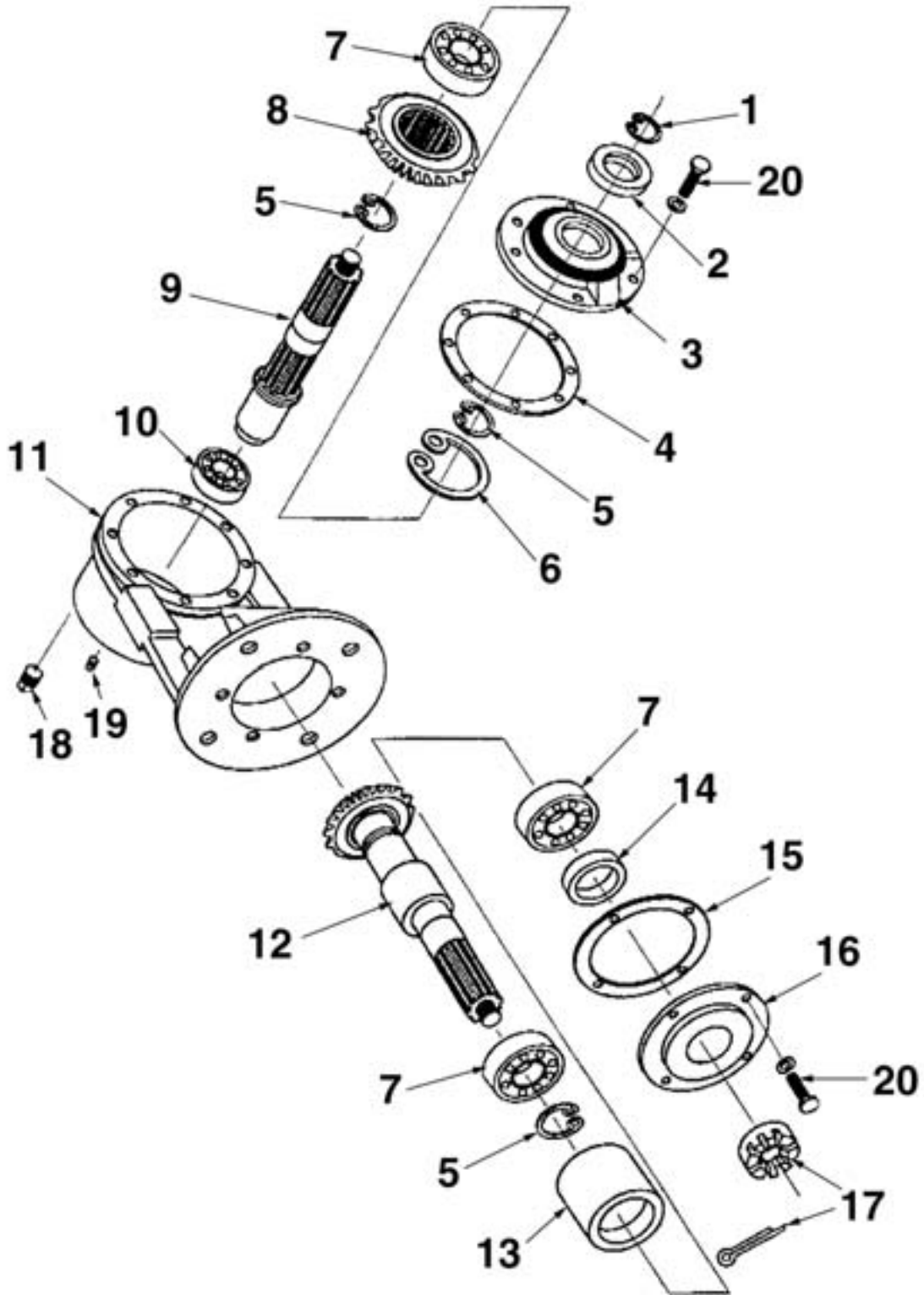



# SLIP CLUTCH GEARBOX ASSEMBLY

<u>REF#</u>	<u>QTY.</u>	<u>PART NO.</u>	<u>DESCRIPTION</u>
1	1	106138	Circlip
2	1	35X54X10	Oil Seal
3	3	129015	Cover, Front
4	1	124130	Gasket
5	1	131031	Circlip
6	1	131030	Circlip
7	3	155005	Bearing 208
8	1	185010	Gear, Input
9	1	186005	Input Shaft
10	1	6207	Bearing
11	1	129010	Housing
12	1	185006	Output Shaft
13	1	131045	Spacer
14	1	40X54X7	Oil Seal
15	1	124131	Gasket
16	1	129005	Cover, Bottom
17	1	501110	Castle Nut 1"
18	1	131035	Plug 1/2" - 14NPT
19	1	131040	Plug 1/8" - 27NPT
20	8	101012	Bolt 3/8" x 1"

# BLADE CARRIER ASSEMBLY

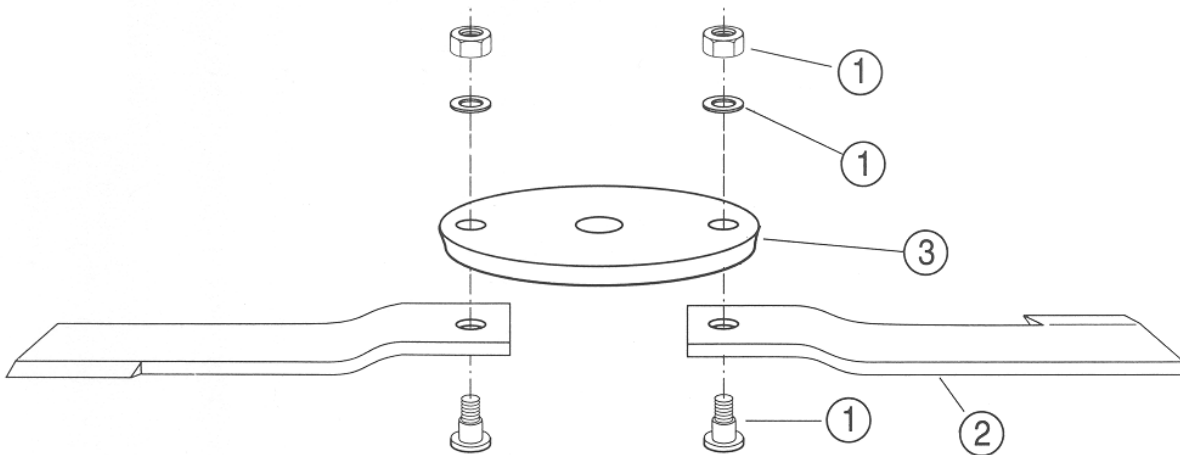

<u>REF#</u>	<u>QTY.</u>	<u>PART NO.</u>	<u>DESCRIPTION</u>
1	1	501001	Blade Bolt Assembly (2 pk)
2	1	501118	Blade Set L-40-40-P & L-48-40-P
2	1	501124	Blade Set L-60-40-P
2	1	501130	Blade Set L-72-40-P
3	1	403030	Stump Jumper L-40-40-P
3	1	403031	Stump Jumper L-48-40-P, L-60-40-P & L-72-40-P

## IMPORTANT

When sharpening blades, grind each blade the same amount to maintain balance. Replace blades in pairs. Unbalanced blades will cause excessive vibration which can damage gearbox bearings. Vibration may also cause structural cracks to cutter.

Sharpen both blades at the same time to maintain balance. Follow original sharpening pattern. Do not sharpen blade to a razor edge, but leave at least a 1/16" blunt edge. Do not sharpen back side of blade.

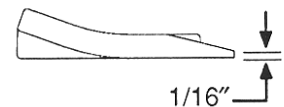
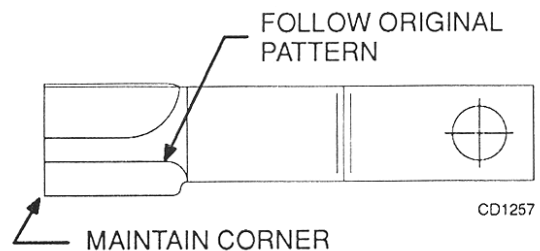

# PTO DRIVELINE L-40 - L-48 147029

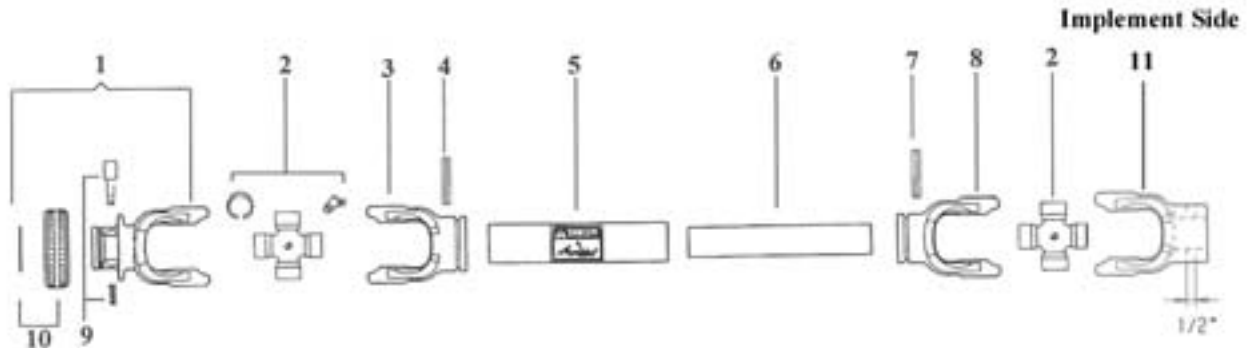

<u>REF#</u>	<u>QTY.</u>	<u>PART NO.</u>	<u>DESCRIPTION</u>
1	1	572040351	RS collar Yoke 1-3/8" 6-Spline
2	2	41204	Cross Kit Assembly #4
3	1	204046851	Outer Tube Yoke #4
4	1	341038000	Roll Pin O.T. #4
5	1	225101200	Outer Drive Tube #4
6	1	225121200	Inner Drive Tube #4
7	1	341048000	Roll Pin I.T. #4
8	1	204046852	Inner Tube Yoke #4
9	2	403000001	Quick Disconnect Pin Kit
10	2	211015363	RS Collar 5-6
11	1	211044955	Yoke 1-3/8" Round Bore
	1	5F04120F6	B & P Shield Kit With Bearings
	1	255040006	B & P Shield Bearing Inner
	1	255040005	B & P Shield Bearing Outer
	1	36728	Eurocardan Shield Kit
	1	35069	Eurocardan Bearing Inner
	1	35066	Eurocardan Bearing Outer

# PTO DRIVELINE L-60 - L-72 147034

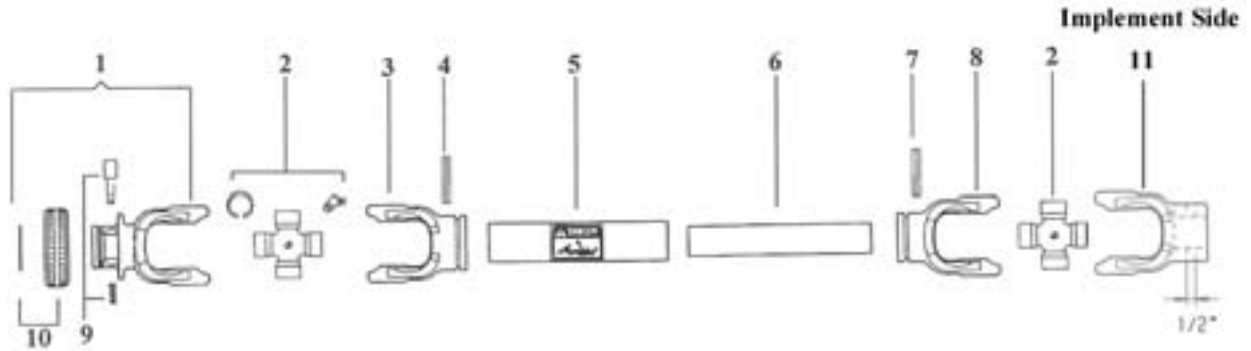

<u>REF#</u>	<u>QTY.</u>	<u>PART NO.</u>	<u>DESCRIPTION</u>
1	1	572050351	RS Collar Yoke 1-3/8" 6-Spline
2	2	41205	Cross Kit Assembly #5
3	1	204056860	Outer Tube Yoke #5
4	1	341053000	Roll Pin O.T. #5
5	1	225701200	Outer Drive Tube #5
6	1	225111200	Inner Drive Tube #5
7	1	341002000	Roll Pin I.T. #5
8	1	204056861	Inner Tube Yoke #5
9	2	403000001	Quick Disconnect Pin Kit
10	2	240003051	RS Collar 5-6
11	1	211054954	Yoke 1-3/8" Round Bore
12	1	572050361	RS Collar Yoke 1-3/8" 6-Spline
	1	5F05086FF	B & P Shield Kit With Bearings
	1	255050006	B & P Shield Bearing Inner
	1	255050005	B & P Shield Bearing Outer
	1	36515	Eurocardan Shield Kit
	1	36521	Eurocardan Bearing Inner
	1	36519	Eurocardan Bearing Outer

# LIMITED WARRANTY



GEARMORE, INC., warrants each new Gearmore product to be free from defects in material and workmanship for a period of twelve (12) months from date of purchase to the original purchaser. This warranty shall not apply to implements or parts that have been subject to misuse, negligence, accident, or that have been altered in any way.

Our obligation shall be limited to repairing or replacement of any part, provided that such part is returned within thirty (30) days from date of failure to Gearmore through the dealer from whom the purchase was made, transportation charges prepaid.

This warranty shall not be interpreted to render us liable for injury or damages of any kind or nature, direct, consequential or contingent, to person or property. This warranty does not extend to loss of crops, loss because of delay in harvesting or any other expenses, for any other reasons.

Gearmore in no way warrants engines, tires, or other trade accessories, since these items are warranted separately by these respective manufacturers.

Gearmore reserves the right to make improvements in design or changes in specification at any time, without incurring any obligations to owners or units previously sold.

GEARMORE, INC.  
13477 Benson Ave.  
Chino, CA 91710

Always refer to and heed machine operating warning decals on machine.

*The serial number of this product is stored in our computer database, thus submitting a warranty registration card is not required.*