

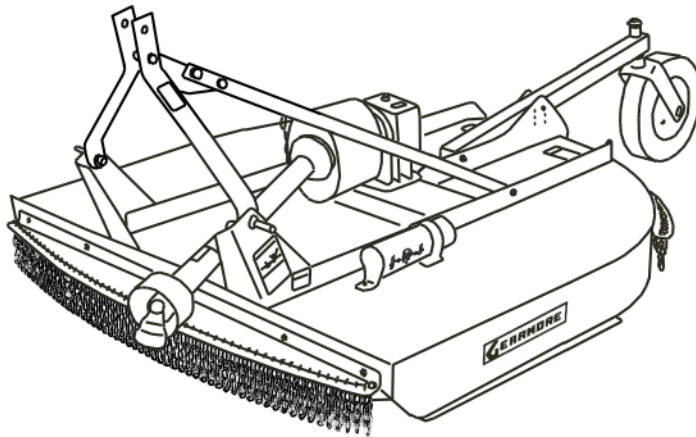

ROTARY MOWER



Operation, Service & Parts Manual For RC200 Series Rotary Mowers

February 2009

TABLE OF CONTENTS

SECTION	DESCRIPTION	PAGE
1	Introduction	4
1.1	Dealer Preparation Checklist	4
1.2	To The Dealer.....	5
1.3	To The Owner	5
2	General Information.....	6
3	Safety Rules.....	7
3.1	Training.....	7
3.2	Preparation	7
3.3	Transportation.....	8
3.4	Operation	8
3.5	Maintenance.....	9
3.6	Storage	9
4	Decals - Safety & Instructional.....	10 - 11
5	General Description	12
5.1	Technical Specifications	13
6	Preparation	14
6.1	Selecting Tractor PTO Speed	14
6.2	Positioning Drawbar.....	14
6.3	Preparing The Cutter	14
6.4	Installing Hitch Pin Bushings	15
6.5	Using Cat. 2, 3-Point Hitch.....	15
6.6	Checking Driveline Shields.....	15
7	Attaching.....	16
7.1	Attaching Cutter To Quick Coupler Hitch	16
7.2	Attaching Cutter To 3-Point Hitch	16
7.3	Assembling PTO Driveline Members	17
7.4	Attaching PTO Driveline.....	17
7.5	Checking Driveline/Cutter Clearance	18
8	Detaching.....	19
8.1	Detaching Cutter From Tractor.....	19
8.2	Tractor with Quick Coupler Hitch.....	19
8.3	Tractor with 3-Point Hitch.....	19
9	Operation	20
9.1	Preparing Cutter for Operation	20
9.2	Adjusting Cutting Height and Angle.....	20
9.3	Safe Operating Procedures.....	21
9.4	Keep Riders Off Machine	22
10	Lubrication & Maintenance.....	23
10.1	Lubricating & Maintaining Machine Safely	23
10.2	Maintenance Checklist.....	23
10.3	Maintenance Before Each Use.....	23
10.4	Maintenance After Each Use	23
10.5	Lubrication Symbols.....	23
10.6	Lubrication Before Each Use	24

TABLE OF CONTENTS

SECTION	DESCRIPTION	PAGE
11	Service	25
11.1	Safe Service Procedures	25
11.2	Disassembling & Assembling Driveline Shlds.....	25
11.3	Disassembling & Inspecting Slip Clutch.....	25
11.4	Assembling Slip Clutch	25
11.5	Removing & Installing Driveline Slip Clutch	26
11.6	Removing & Installing Driveline Shear Bolt	27
11.7	Replacing Driveline Shear Bolt	27
11.8	Removing & Installing Tailwheel Support.....	27
11.9	Checking Blade Wear	27
11.10	Replacing Blades.....	28
11.11	Direction of Blade Rotation.....	28
11.12	Replacing Blade Pan.....	29
11.13	Replacing Tailwheel Pivot/Spindle	29
12	Storage.....	29
12.1	At The End Of Cutting Season	29
13	Assembly.....	30
13.1	Predelivery Service	30
13.2	Removing Shipping Dunnage.....	30
13.3	Assemble Hitch	31
13.4	Install Tailwheel Support	31
13.5	Install Tailwheel.....	32
13.6	Install Driveline.....	32
13.7	Fill Gearbox.....	32
13.8	Install Front Deflector Chains	32
13.9	Install Front Deflector Rubber.....	33
13.10	Install Foot Guards.....	33
13.11	Install Rear Deflector Chains	33
13.12	Install Rear Deflector Rubber	33
13.13	Final Inspection & Adjustments.....	34
13.14	Modifying Driveline	34
14	Torque Specifications.....	35
15	Troubleshooting Guide	36
16	Parts	37
16.1	Overall View.....	37
16.2	Hitch Assembly	38
16.3	Gearbox & Blade Pan Assembly	39
16.4	Gearbox	40
16.5	Shear Pin Driveline Assembly	41
16.6	Slip Clutch Driveline Assembly	42
16.7	Tailwheel Assembly.....	43
16.8	Rubber Belt & Foot Guard Assembly	44
16.9	Chain Guard Assembly	45
17	Limited Warranty.....	46

1 INTRODUCTION

1.1 DEALER PREPARATION CHECKLIST

THIS CHECKLIST IS TO REMAIN IN OWNER'S MANUAL
It is the responsibility of the dealer to complete the procedures listed below before the delivery or the sale of this implement to the customer.

- 1. Implement is completely assembled.
- 2. Gearbox filled with oil and check for possible leaks. (*See Lubrication & Maintenance Section*)
- 3. All fittings lubricated. (*See Lubrication & Maintenance Section*)
- 4. All shields are in place and in good condition.
- 5. All fasteners torqued to specifications given in Torque Chart. (*See Torque Specifications*)
- 6. Check PTO driveline. Make sure it is the correct length to operate rotary cutter with intended tractor.
- 7. Check front of input gearbox shaft and make sure that snap ring is properly installed (PTO shaft shear pin only).
- 8. Check shear bolt for proper grade and installation.
- 9. All decals in place and readable. (See page 10-11)
- 10. Overall condition good (i.e. paint, welds, etc.)
- 11. Operator's manual has been given to owner and the owner has been instructed on the safe and proper use of the rotary cutter.

Dealer's Signature: _____

Purchaser's Signature: _____

1 INTRODUCTION (*CONTINUED*)

1.2 TO THE DEALER

Assembly and proper installation of this product is the responsibility of the dealer. Read manual instructions and safety rules. Make sure all items on the Preparation Check List in the Operator's Manual are completed before releasing equipment to the owner.

1.3 TO THE OWNER

Read this manual before operating your equipment. The information presented will prepare you to do a better and safer job. Keep this manual handy for ready reference. Require all operators to read this manual carefully and become acquainted with all the adjustment and operating procedures before attempting to operate. Replacement manuals can be obtained from your selling dealer.

The equipment you have purchased has been carefully engineered and manufactured to provide dependable and satisfactory use. Like all mechanical products, it will require cleaning and upkeep. Lubricate the unit as specified. Observe all safety information in this manual and safety decals on the equipment.

For service, your authorized dealer has trained mechanics, genuine service parts, and the necessary tools and equipment to handle all your needs.

Use only genuine service parts. Substitute parts will void the warranty and may not meet standards required for safe and satisfactory operation. Record the model number, serial number and date of purchase in the spaces provided.

MODEL: _____ **DATE OF PURCHASE:** _____

SERIAL NO: _____ (*See Safety Decal section for location*)

Provide this information to your dealer to obtain correct repair parts.

Throughout this manual, the term **IMPORTANT** is used to indicate that failure to observe can cause damage to equipment. The terms **CAUTION**, **WARNING** and **DANGER** are used in conjunction with the Safety-Alert Symbol, (a triangle with an exclamation mark), to indicate the degree of hazard for items of personal safety.



This Safety-Alert Symbol indicates a hazard and means **ATTENTION! BECOME ALERT! YOUR SAFETY IS INVOLVED!**



Indicates an imminently hazardous situation that, if not avoided, will result in death or serious injury.



WARNING

Indicated a potentially hazardous situation that, if not avoided, could result in death or serious injury, and includes hazards that are exposed when guards are removed.



CAUTION

Indicates a potentially hazardous situation that, if not avoided, may result in minor or moderate injury.

IMPORTANT

Indicates that failure to observe can cause damage to equipment.

NOTE

Indicates helpful information.

2 GENERAL INFORMATION

All information, illustrations, and specifications in this manual are based on the latest information available at the time of publication. The right is reserved to make changes at any time without notice.

The purpose of this manual is to assist you in operating and maintaining your rotary cutter. Read it carefully. It furnishes information and instructions that will help you achieve years of dependable performance. These instructions have been compiled from extensive field experience and engineering data. Some information may be general in nature due to unknown and varying operating conditions. However, through experience and these instructions, you should be able to develop procedures suitable to your particular situation.

The illustrations and data used in this manual were current at the time of printing, but due to possible inline production changes, your machine may vary slightly in detail. We reserve the right to redesign and change the machines as may be necessary without notification.



WARNING: Some illustrations in this manual show the rotary cutter with safety shields removed to provide a better view. The rotary cutter should never be operated with any safety shielding removed.

Throughout this manual, references are made to right and left direction. These are determined by standing behind the equipment facing the direction of forward travel. Blade rotation is counterclockwise as viewed from the top of the mower.

3 SAFETY RULES



ATTENTION! BECOME ALERT! YOUR SAFETY IS INVOLVED!



Safety is a primary concern in the design and manufacture of our products. Unfortunately, our efforts to provide safe equipment can be wiped out by an operator's single careless act.

In addition to the design and configuration of equipment, hazard control and accident prevention are dependent upon the awareness, concern, judgment, and proper training of personnel involved in the operation, transport, maintenance, and storage of equipment.

It has been said "*The best safety device is an informed, careful operator.*" We ask you to be that kind of operator.

3.1 TRAINING

Safety instructions are important! Read all attachment and power unit manuals; follow all safety rules and safety decal information. (Replacement manuals and safety decals are available from your dealer.) Failure to follow instructions or safety rules can result in serious injury or death.

If you do not understand any part of this manual and need assistance, see your dealer.

Know your controls and how to stop engine and attachment quickly in an emergency.

Operators must be instructed in and be capable of the safe operation of the equipment, its attachments, and all controls. **Do not** allow anyone to operate this equipment without proper instructions.

Never allow children or untrained persons to operate equipment.

3.2 PREPARATION

Check that all hardware is properly installed. Always tighten to torque chart specifications unless instructed otherwise in this manual.

Always wear relatively tight and belted clothing to avoid getting caught in moving parts. Wear sturdy, rough-soled work shoes and protective equipment for eyes, hair, hands, hearing, and head; and respirator or filter mask where appropriate.

Make sure attachment is properly secured, adjusted, and in good operating condition. Make sure collar slides freely and is seated firmly in tractor PTO spline groove.

Before putting equipment into service check and adjust driveline length as instructed in Operator's manual. Driveline must not bottom out or pull apart throughout the full range of the tractor hitch. Do not operate until driveline length is correct.

Make sure driveline shield safety chain is attached as shown in this manual. Replace if damaged or broken. Check that driveline guards rotate freely on driveline before putting equipment into service.

Before starting power unit, check all equipment driveline guards for damage. Replace any damaged guards. Make sure all guards rotate freely on all drivelines. If guards do not rotate freely on drivelines, repair and replace bearings before putting equipment into service.

Inspect chain or rubber deflectors before each use. Replace if damaged.

Remove accumulated debris from this equipment, power unit, and engine to avoid fire hazard.

Power unit must be equipped with ROPS or ROPS cab and seat belt. Keep seat belt securely fastened. Falling off power unit can result in death from being run over or crushed. Keep foldable ROPS system in "locked up" position at all times.

Make sure all safety decals are installed. Replace if damaged. (*See Safety Decals section for location.*) Make sure shields and deflectors are properly installed and in good condition. Replace if damaged.

3 SAFETY RULES (*CONTINUED*)



ATTENTION! BECOME ALERT! YOUR SAFETY IS INVOLVED!



A minimum of 20% of tractor and equipment weight must be on the tractor front wheels when attachments are in transport position. Without this weight, tractor could tip over, causing personal injury or death. The weight may be attained with a loader, front wheel weights, ballast in tires or front tractor weights. Weigh the tractor and equipment. Do not estimate.

Inspect and clear area of stones, branches, or other hard objects that might be thrown, causing injury or damage.

3.3 TRANSPORTATION

Power unit must be equipped with ROPS or ROPS cab and seat belt. Keep seat belt securely fastened. Falling off power unit can result in death from being run over or crushed. Keep foldable ROPS system in "locked up" position at all times.

Verify that a minimum of 20% of the tractor and equipment weight must be on the tractor front wheels when attachments are in transport position.

Always comply with all state and local lighting and marking requirements.

Never allow riders on power unit or attachment.

Do not operate PTO during transport.

Watch for hidden hazards on the terrain.

Do not operate or transport on steep slopes.

Do not operate or transport equipment while under the influence of alcohol or drugs.

3.4 OPERATION

Do not allow bystanders in the area when operating, attaching, removing, assembling, or servicing equipment.

Never direct discharge toward people, animals, or property.

Use both front and rear deflectors to reduce the possibility of objects being thrown.

These mowers are intended for agricultural applications only. Do not operate within 300 feet of bystanders or public roads or highways.

Do not operate or transport equipment while under the influence of alcohol or drugs.

Keep hands, feet, hair, and clothing away from equipment while engine is running. Stay clear of all moving parts.

Operate only in daylight or good artificial light. Always comply with all state and local lighting and marking requirements.

Never allow riders on power unit or attachment.

Power unit must be equipped with ROPS or ROPS cab and seat belt. Keep seat belt securely fastened. Falling off power unit can result in death from being run over or crushed. Keep foldable ROPS system in "locked up" position at all times.

Always sit in power unit seat when operating controls or starting engine. Securely fasten seat belt, place transmission in neutral, engage brake, and ensure all controls are disengaged before starting power unit engine.

Operate tractor PTO at 540 RPM. Do not exceed.

Do not operate PTO during transport.

Look down and to the rear and make sure area is clear before operating in reverse.

Do not operate or transport on steep slopes.

Do not stop, start, or change directions suddenly on slopes.

Use extreme care and reduce ground speed on slopes and rough terrain.

Watch for hidden hazards on the terrain during operation.

3 SAFETY RULES (CONTINUED)



ATTENTION! BECOME ALERT! YOUR SAFETY IS INVOLVED!



Stop power unit and equipment immediately upon striking an obstruction. Turn off engine, remove key, inspect, and repair any damage before resuming operation.

Leak down or failure of mechanical or hydraulic system can cause equipment to drop.

3.5 MAINTENANCE

Before dismounting power unit or performing any service or maintenance, follow these steps: disengage power to equipment, lower the 3-point hitch and all raised components to the ground, set parking brake, stop engine, remove key, and unfasten seat belt.

Before performing any service or maintenance, disconnect driveline from tractor PTO.

Before working underneath, carefully read Operator's Manual instructions, disconnect driveline, raise mower, securely block up all corners with jackstands, and check stability. Secure blocking prevents equipment from dropping due to hydraulic leak down, hydraulic system failures, or mechanical component failures.

Do not modify or alter or permit anyone else to modify or alter the equipment or any of its components in any way.

Always wear relatively tight and belted clothing to avoid getting caught in moving parts. Wear sturdy, rough-soled work shoes and protective equipment for eyes, hair, hands, hearing, and head; and respirator or filter mask where appropriate.

Make sure attachment is properly secured, adjusted, and in good operating condition.

Keep all persons away from operator control area while performing adjustments, service, or maintenance.

Never go underneath equipment (lowered to the ground or raised) unless it is properly blocked and secured. Never place any part of the body underneath equipment or between moveable parts even when the engine has been turned off. Hydraulic system leak down, hydraulic system failures, mechanical failures, or movement of control levers can cause equipment to drop or rotate unexpectedly and cause severe injury or death. Follow Operator's Manual instructions for working underneath and blocking requirements or have work done by a qualified dealer.

Make certain all movement of equipment components has stopped before approaching for service.

Frequently check blades. They should be sharp, free of nicks and cracks, and securely fastened.

Do not handle blades with bare hands. Careless or improper handling may result in serious injury.

Your dealer can supply genuine replacement blades. Substitute blades may not meet original equipment specifications and may be dangerous.

Tighten all bolts, nuts, and screws to torque chart specifications. Check that all cotter pins are installed securely to ensure equipment is in a safe condition before putting unit into service.

Make sure all safety decals are installed. Replace if damaged. (*See Safety Decals section for location.*)

Make sure shields and deflectors are properly installed and in good condition. Replace if damaged.

3.6 STORAGE

Block equipment securely for storage.

Keep children and bystanders away from storage area.

Follow manual instructions for storage.

4 DECALS - SAFETY AND INSTRUCTIONAL



ATTENTION! BECOME ALERT! YOUR SAFETY IS INVOLVED!
Replace Immediately if Damaged!

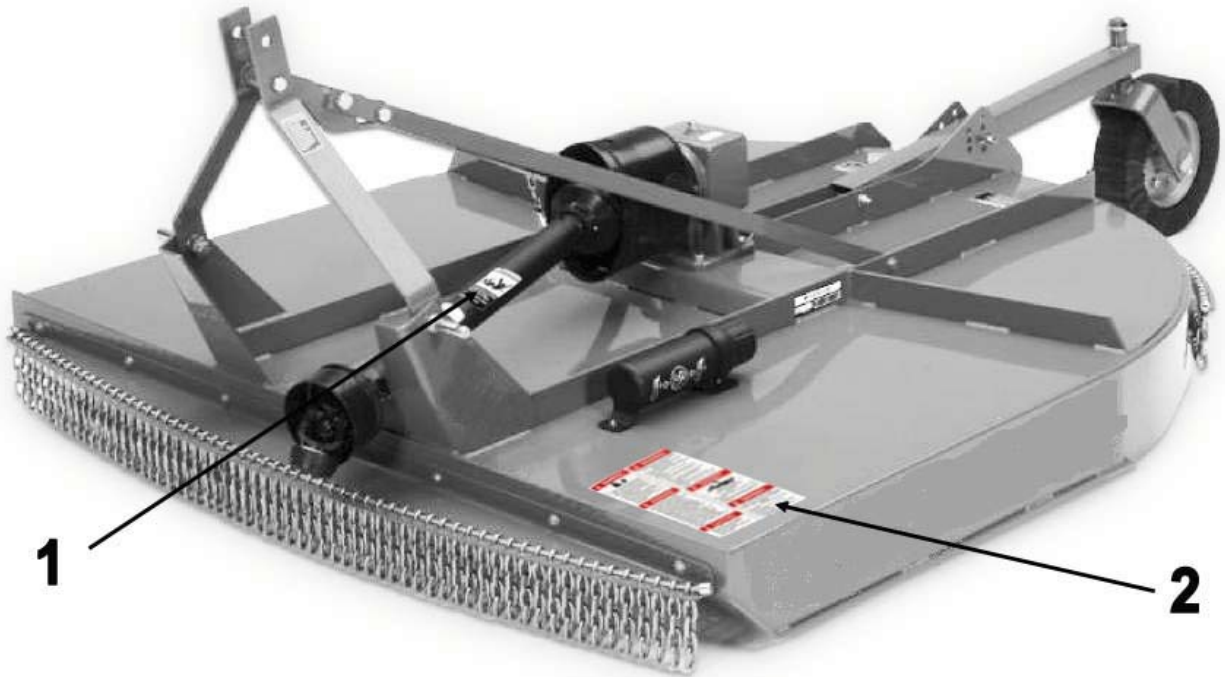

RC200 With Laminated Tailwheel



① Entanglement

4 DECALS - SAFETY AND INSTRUCTIONAL (CONTINUED)



ATTENTION! BECOME ALERT! YOUR SAFETY IS INVOLVED!



Replace Immediately if Damaged!



WARNING



ROTARY CUTTERS MAY DISCHARGE OBJECTS AT HIGH SPEEDS, WHICH COULD RESULT IN SERIOUS INJURY TO BY-STANDERS OR PASSERS-BY.

- DO NOT OPERATE CUTTER IN VICINITY OF OTHER PERSONS.
- KEEP ENCLOSED SIDES, PERMANENT BANDS, BELTING, HIGHWAY CHAINS OR OTHER FACTORY APPROVED DISCHARGE SHIELDS IN PLACE AND IN GOOD REPAIR.



WARNING

TO AVOID SERIOUS INJURY OR DEATH,

- READ OPERATOR'S MANUAL BEFORE OPERATING & FOLLOW ALL PRECAUTIONS. (CONTACT DEALER FOR MANUALS.)
- KEEP SHIELDS AND GUARDS IN PLACE. KEEP CLEAR OF DRIVES AND BELTS.
- LOWER IMPLEMENT, STOP ENGINE AND REMOVE KEY BEFORE DISMOUNTING.
- SECURELY SUPPORT MOWER & REMOVE KEY BEFORE WORKING UNDERNEATH.
- NO RIDERS. DO NOT OPERATE MOWER IN VICINITY OF OTHER PERSONS.
- KNOW HOW TO STOP TRACTOR AND EQUIPMENT QUICKLY IN AN EMERGENCY.
- CLEAR MOWING AREA OF DEBRIS.
- ALLOW NO CHILDREN OR UNQUALIFIED PERSONS TO OPERATE EQUIPMENT.
- BE CAREFUL ON UNEVEN TERRAIN. DECREASE SPEED WHEN TURNING.
- DO NOT OPERATE MOWER IN TRANSPORT POSITION.



CAUTION

THIS IMPLEMENT IS DESIGNED TO OPERATE AT 540 RPM MAXIMUM TRACTOR PTO SPEED. ALL DRIVE LINE SHIELDS MUST BE KEPT IN PLACE.



WARNING

IMPLEMENT CAN FALL FROM HYDRAULIC SYSTEM FAILURE. TO AVOID SERIOUS INJURY OR DEATH,

- BLOCK UP OR SECURELY SUPPORT IMPLEMENT BEFORE WORKING UNDERNEATH.
- PURGE ALL AIR FROM HYDRAULIC SYSTEM BEFORE ATTEMPTING TO RAISE OR LOWER THIS IMPLEMENT.
- STAND CLEAR IF LOWERING OR RAISING IMPLEMENT.
- DO NOT USE HAND OR SKIN TO CHECK FOR HYDRAULIC LEAKS. USE CARDBOARD OR WOOD.
- HIGH PRESSURE OIL LEAKS CAN PENETRATE SKIN CAUSING SERIOUS INJURY AND GANGRENE. CONSULT A PHYSICIAN IMMEDIATELY.
- LOWER THE IMPLEMENT AND RELEASE HYDRAULIC PRESSURE BEFORE LOOSENING FITTINGS.
- REFER TO OWNERS MANUAL FOR DETAILS.



DANGER



ROTATING DRIVELINE CONTACT CAN CAUSE DEATH
KEEP AWAY!

DO NOT OPERATE WITHOUT -

- ALL DRIVELINE, TRACTOR AND EQUIPMENT SHIELDS IN PLACE
- DRIVELINES SECURELY ATTACHED AT BOTH ENDS
- DRIVELINE SHIELDS THAT TURN FREELY ON DRIVELINE



DANGER

KEEP AWAY-ROTATING BLADES
SERIOUS INJURY OR DEATH CAN RESULT FROM THROWN OBJECTS OR BLADE CONTACT.

- DO NOT STAND ON OR NEAR MACHINE WHEN IN OPERATION.
- DO NOT OPERATE WITH DEFLECTORS OR GUARDS REMOVED.
- ROPS (ROLLOVER PROTECTIVE SYSTEM) AND SEAT BELT EQUIPPED TRACTOR IS RECOMMENDED FOR OPERATOR USE IN ALL MOWING OPERATIONS.

② General Safety Decal

5 GENERAL DESCRIPTION

Your 200 Series Rotary Cutter has been carefully designed for cutting grass and small brush. This manual is provided to give you the necessary operation and maintenance instructions for keeping your rotary cutter in excellent operating condition. Please read this manual thoroughly. Understand the purpose of the controls and how to use them. Observe all safety precautions on the machine and as noted throughout this manual. If any assistance or additional information is needed, contact your authorized dealer. Each cutter has free swinging blades which reduce the shock on impact when a stationary object is hit. A shear bolt through the input shaft or slip clutch equipped driveline protects the gearbox and driveline from damage.

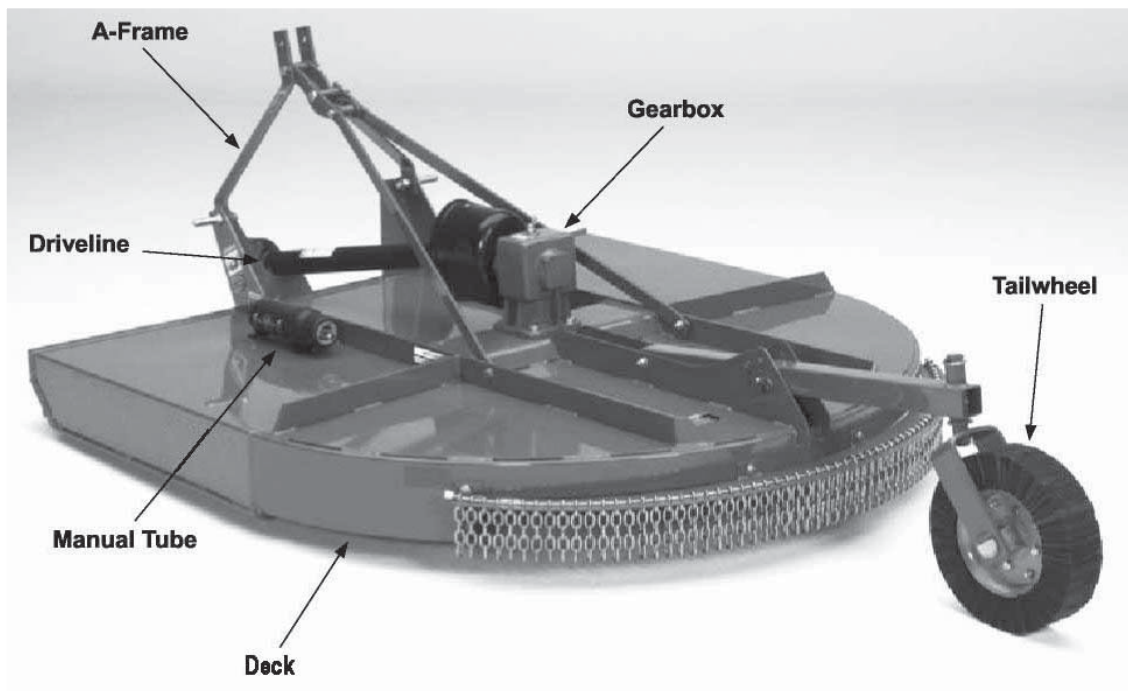

5 GENERAL DESCRIPTION (CONTINUED)

5.1 TECHNICAL SPECIFICATIONS

MODEL:	RC200-48	RC200-60	RC200-72	RC200-84
Capacity				
Cutting Width:	48"	60"	72"	84"
Cutting Height:	1 ½" to 9"	1 ½" to 9"	1 ½" to 9"	1 ½" to 9"
Cutting Capacity (diameter):	up to 1"	up to 1"	up to 1"	up to 2"
Cutting Chamber Depth:	7 ½"	7 ½"	7 ½"	
Tractor PTO HP Range:	Minimum 18	Minimum 20	Minimum 25	Minimum 85
Tractor PTO:	540	540	540	540
Hitch				
Type - Lift:	Match or Non-match	Match or Non-match	Match or Non-match	
Category:	1, adaptable to 2	1, adaptable to 2	1, adaptable to 2	1, adaptable to 2
Overall Width:	51.4"	63.1"	75.6"	
Overall Length:	86.6"	98.4"	110.8"	
Deck Shape:	Flat-open round back	Flat-open round back	Flat-open round back	Step-open round back
Deck Type:	Single	Single	Single	Double
Approximate Weight:	512 lbs.	584 lbs.	710 lbs.	1100 lbs.
Deck Thickness:	11 gauge	11 gauge	11 gauge	
Skirt Thickness:	11 gauge	11 gauge	11 gauge	
Driveline				
Type:	Shear Bolt or Slip Clutch	Shear Bolt or Slip Clutch	Shear Bolt or Slip Clutch	Slip Clutch
Gearbox				
HP Rating:	45 HP	65 HP	65 HP	90 HP
Blades				
Thickness:	½"	½"	½"	½"
Width:	3"	3"	3"	4"
Type:	Heat Treated Suction	Heat Treated Suction	Heat Treated Suction	Heat Treated Suction
Blade Tip Speed:	13,090 ft./min.	12,465 ft./min.	14,955 ft./min.	17,448 ft./min.
Blade Holder				
Type:	Round Pan-type	Round Pan-type	Round Pan-type	Round Pan-type
Diameter:	24"	24"	36"	
Wheels				
Type:	Solid Rubber or Laminated	Solid Rubber or Laminated	Solid Rubber or Laminated	Laminated
Diameter, Laminated:	15"	15"	15"	15"
Width, Laminated:	3.75"	3.75"	3.75"	3.75"
Diameter, Rubber:	16"	16"	16"	
Width, Rubber:	3.75"	3.75"	3.75"	
Enclosure Options				
Front Deflector:	Foot Guard/Belting or Chain	Foot Guard/Belting or Chain	Foot Guard/Belting or Chain	Foot Guard/Belting or Chain
Rear Deflector:	Belting or Chain	Belting or Chain	Belting or Chain	

6 PREPARATION

6.1 SELECTING TRACTOR PTO SPEED

IMPORTANT: Never operate a cutter equipped for 540 rpm PTO drive with a factor equipped to 1000 rpm PTO.

Always run tractor at rated PTO speed.
Overspeed will cause damage to drive system.

Refer to your tractor Operator's Manual to change PTO stub shaft, if necessary.

6.2 POSITIONING DRAWBAR

IMPORTANT: To prevent damage to the driveline, remove, shorten, or place drawbar to one side. If equipped with clevis, remove it.

6.3 PREPARING THE CUTTER

Perform the following procedures before operating the cutter:

Gearbox:

- Check oil level. (*See Lubrication and Maintenance section.*)
- Check hardware torque. (*See Lubrication and Maintenance section.*)
- Remove any material wound on gearbox shafts.
- Check oil seals for leakage.

Blades and Blade Holder:

- Inspect blades for wear or damage. (*See Checking Blade Wear in Service section.*)
- Check blade hardware torque. (*See Lubrication and Maintenance section.*)
- Check blade holder hardware torque. (*See Lubrication and Maintenance section.*)

Hitch Pins:

- Check torque on hitch pin lock nut.
- Insure all bolts on cutter are fastened securely.

Lubricating the Cutter:

- Lubricate cutter and drivelines. (*See Lubrication and Maintenance section.*)

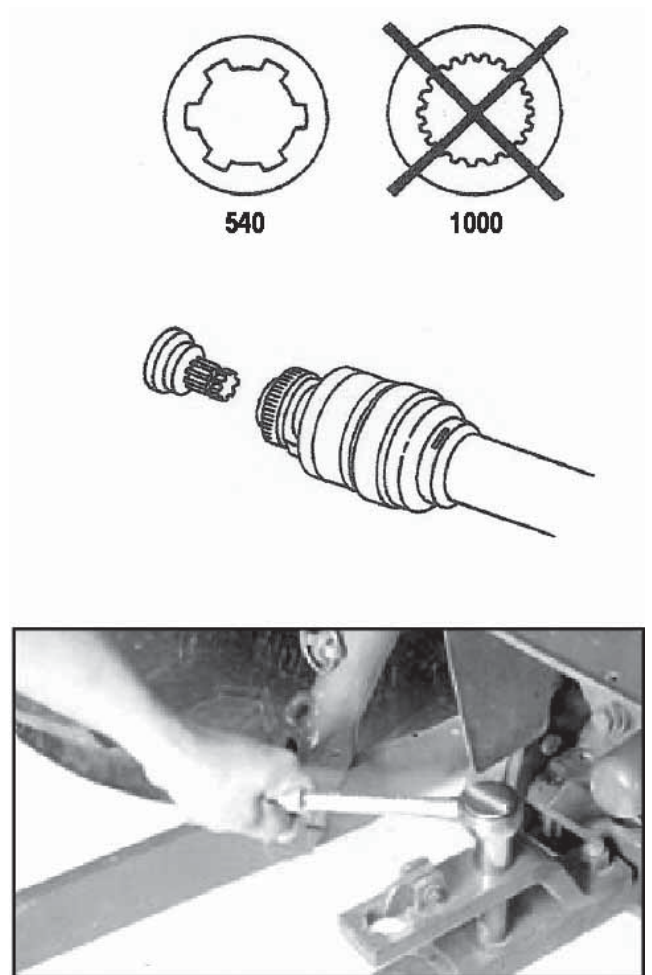

6 PREPARATION (CONTINUED)

6.4 INSTALLING HITCH PIN BUSHINGS FOR CAT. 1 QUICK COUPLER HITCH

NOTE: Install bushings on both hitch pins. Right-hand side shown. Use category 1 quick coupler bushing kit or continue to step 2.

1. Install bushing (A) over hitch pin with cross hole as shown.
2. Install bushing (B) as shown.
3. Align holes in bushings with hole in hitch pin and install spring pin (C).

- A - Bushing
- B - Bushing
- C - Spring Pin

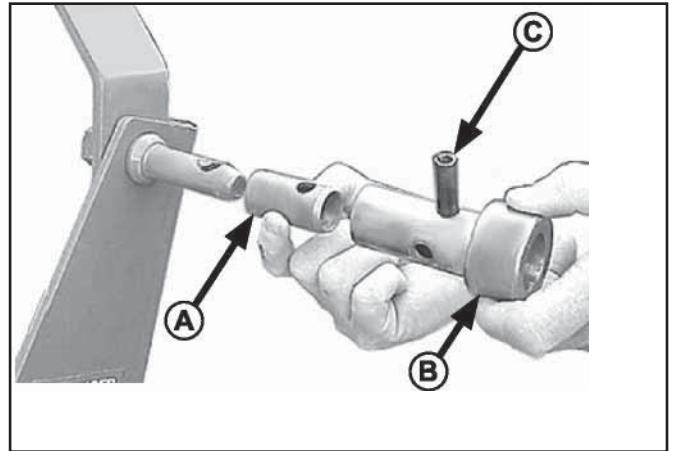

6.5 USING CAT. 2, 3-POINT HITCH

Special adapter bushings are available to accommodate tractors with category 2, 3-point hitch.

Install bushings on cutter hitch pins and tractor center link connection.

- A - Center Link Connection
- B - Hitch Pins

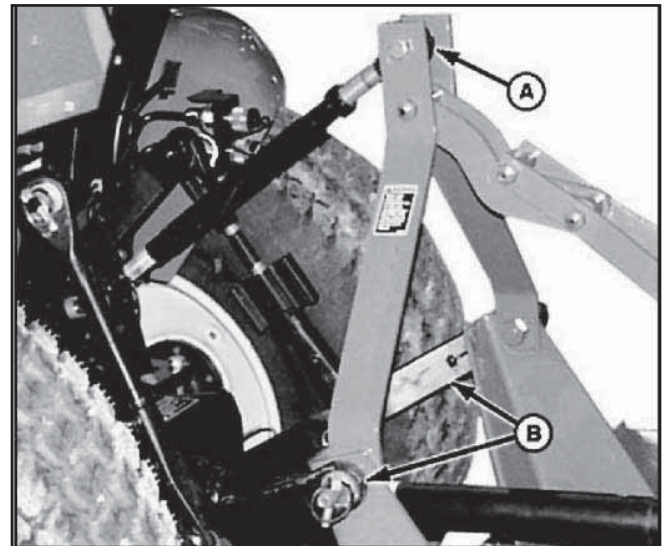

6.6 CHECKING DRIVELINE SHIELDS



Entanglement in rotating driveline can cause serious injury or death. Disengage PTO, engage parking brake or place transmission in "PARK", shut off tractor, and remove key before working near driveline.

Check driveline shields by making sure they rotate freely.

Lubricate or repair if necessary.

- A - Driveline Shield

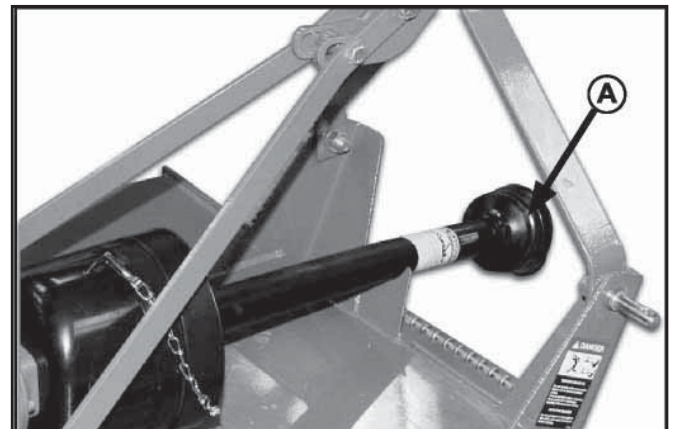

7 ATTACHING

7.1 ATTACHING CUTTER TO TRACTOR WITH QUICK COUPLER HITCH



CAUTION: To avoid bodily injury or machine damage whenever an implement is attached, put transmission in **PARK** position and check the full range of hitch for interference, binding, or PTO separation. Do not stand between tractor and implement.

1. Slowly push hitch control lever to lower hitch until quick coupler hooks are lower than cutter hitch pins.
2. Back up tractor to cutter hitch.
3. Raise hitch high enough to engage cutter hitch pins in hooks.
4. Engage tractor parking brake and/or place transmission in "Park".
5. Shut off tractor engine and remove key.
6. See *ATTACHING PTO DRIVELINE* in this section.
7. Start tractor engine.
8. Slowly pull hitch control lever to raise cutter. Check for interference. (See *CHECKING DRIVELINE/CUTTER CLEARANCE* in this section.)
9. Lower cutter to ground and adjust if necessary.

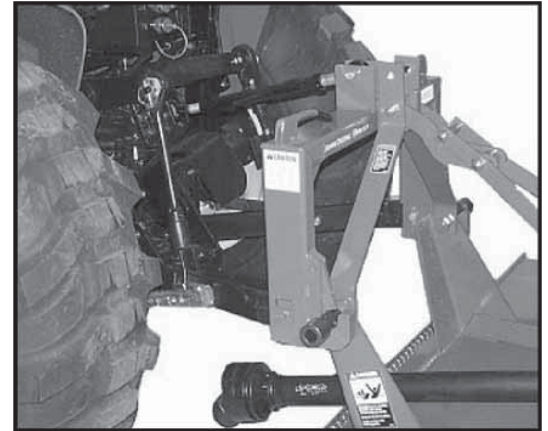

7.2 ATTACHING CUTTER TO TRACTOR WITH 3-PT. HITCH



CAUTION: To avoid bodily injury or machine damage whenever an implement is attached, put transmission in **PARK** position and check the full range of hitch for interference, binding, or PTO separation. Do not stand between tractor and implement.

1. Back up tractor to cutter with hitch points approximately in alignment.
2. Engage tractor parking brake and/or place transmission in "Park".
3. Shut off tractor engine and remove key.
4. Remove center link mounting hardware and hitch pin assemblies at both hitch masts.
5. Install tractor draft links on hitch pins. Secure with quick-lock pins (stored on tractor draft links).
6. Align center link with upper hole in cutter mast straps and install center link mounting hardware.
7. See *ATTACHING PTO DRIVELINE* in this section.
8. Start tractor engine.
9. Slowly pull hitch control lever to raise cutter. Check for interference. (See *CHECKING DRIVELINE/CUTTER CLEARANCE* in this section.)
10. Lower hitch to ground and adjust center link and/or lift links if necessary. (See procedures in your tractor Operator's Manual.)

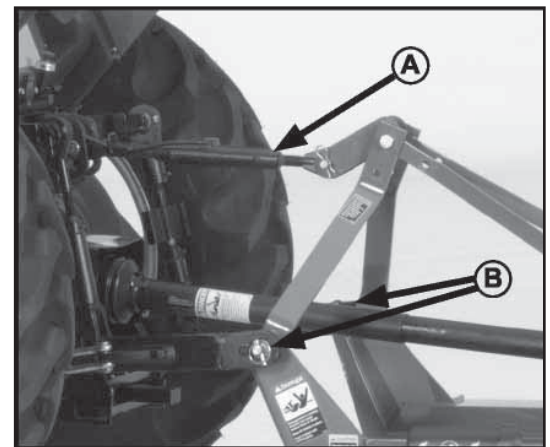

*A - Tractor Center Link
B - Tractor Draft Links*

7 ATTACHING (CONTINUED)

7.3 ASSEMBLING PTO DRIVELINE TELESCOPING MEMBERS (IF NECESSARY)

1. Apply multipurpose grease around outside surface of inner driveline tube (A).
2. Align driveline halves and assemble telescoping members together.
3. Apply multipurpose grease, or equivalent, to all lubrication fittings before operating. (*See Lubrication and Maintenance section.*)

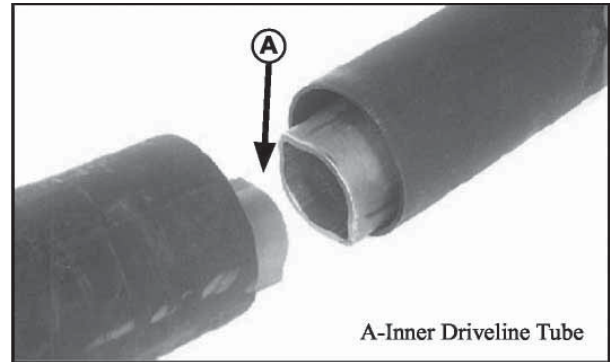

7.4 ATTACHING PTO DRIVELINE



Shut off tractor engine before attaching PTO driveline. Entanglement in rotating driveline can cause serious injury or death.

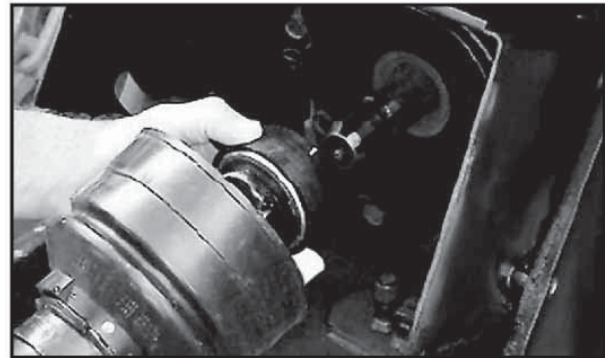

IMPORTANT! Keep driveline and powershaft splines clean of paint, dirt and chaff. Apply John Deere SD POLYUREA Grease or equivalent on tractor PTO shaft before attaching PTO driveline.

1. Shut off tractor engine.
2. Raise tractor PTO shield, if equipped.

IMPORTANT! Do not use bell on driveline to lift driveline into position. Damage to shielding can occur.

3. Support driveline, cradling it in your hand.
4. Pull collar back toward cutter. Align splines by rotating cutter driveline. Push driveline onto tractor PTO shaft until collar snaps into place.
5. Pull back on shield to make sure driveline is locked.
6. Do not pull back on collar, this will release latch.
7. Lower tractor PTO shield, if equipped.

IMPORTANT! Slip clutch components must be free to rotate when necessary. After long idle periods, linings of slip clutch may draw moisture. Linings may bond to metal parts causing slip clutch to be ineffective, resulting in machine damage.

8. If cutter was not used for a while, free slip clutch, if equipped. (*See procedure in Lubrication and Maintenance section.*)

7 ATTACHING (CONTINUED)

7.5 CHECKING DRIVELINE/CUTTER CLEARANCE

IMPORTANT! Prevent driveline damage from contact with frame or machine damage from contact with tractor tires. Raise cutter slowly and check for interference. If necessary, shorten center link or lengthen lift links to provide clearance to full lift height.

1. Raise cutter slowly and check for clearance between driveline shield and cutter deck.
2. Check clearance between tractor tires and foot guards or chain deflector.
3. Check to see if hitch height position will provide clearance desired.

*NOTE: Final adjustments should be made before operating cutter. See **ADJUSTING CUTTING HEIGHT AND ANGLE** in **Operating the Cutter** section. Center link should be installed in lowest hole at tractor end if there are multiple holes. Lift height may also be limited by installing stops on rockshaft control lever bracket.*

4. Shorten center link or lengthen lift links to provide clearance. (See your Tractor Operator's Manual.)

IMPORTANT! PTO driveline may be too long for some tractor models, causing tractor transaxle damage.

5. Raise and lower cutter slowly to check for binding or interference. Check cutter-to-tractor driveline telescoping length to ensure it does not bottom out. Modify driveline if necessary. (See **ATTACHING PTO DRIVELINE** in this section.)

8.1 DETACHING CUTTER FROM TRACTOR



CAUTION! To prevent personal injury caused by unexpected movement:

- a. Park machine on a level surface
- b. Engage tractor parking brake and/or place transmission in "Park".
- c. Disengage PTO.
- d. Shut off tractor engine and remove key.



1. Park cutter on a level surface, or block tailwheel so machine cannot roll after detaching from the tractor.
2. Slowly push hitch control lever to lower cutter close to the ground.
3. Engage tractor parking brake and/or place transmission in "Park".



CAUTION! Shut off tractor engine before detaching PTO driveline. Entanglement in rotating driveline can cause serious injury or death.

4. Shut off tractor engine and remove key.
5. Raise tractor PTO shield, if equipped.

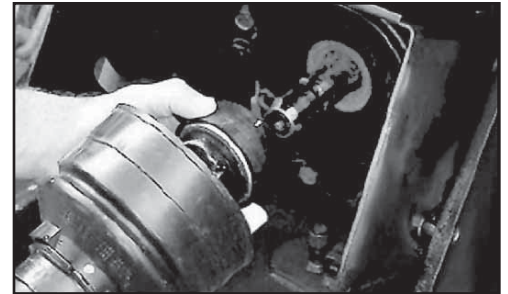

IMPORTANT! Do not use plastic shield on driveline to hold driveline in position. Damage to shielding can occur.

6. Pull collar back toward cutter and slide drive line off tractor shaft.
7. Support and collapse driveline completely and lower onto PTO holder.
8. Lower tractor PTO shield, if equipped.

8.2 TRACTOR WITH QUICK COUPLER HITCH

1. Raise both latch control levers on quick coupler (A).
2. Start tractor engine.
3. Lower cutter to the ground. Continue lowering quick coupler until hooks clear cutter hitch pins.
4. Carefully drive tractor away.

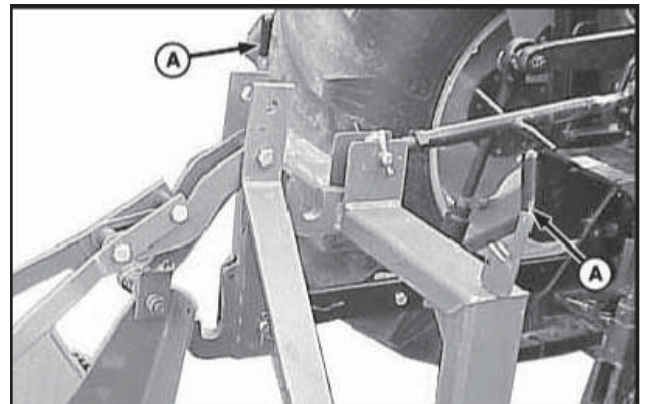

8.3 TRACTOR WITH THREE-POINT HITCH

1. Remove quick-lock pins from hitch pins and install in storage position on tractor draft links.
2. Remove and lower tractor draft links from hitch pins.
3. Disconnect center link from mast straps. Position tractor center link in transport location. Reinstall center link pin/hardware.
4. Carefully drive tractor away.

IMPORTANT! After long idle periods, linings of slip clutch may draw moisture. Linings may bond to metal parts causing slip clutch to be ineffective. Loosen all lock nuts on slip clutch. This will relieve spring load on the disks reducing this problem during storage.

9 OPERATION

General Safety:

Only qualified people should operate this machine, It is recommended that tractor be equipped with Rollover Protective Systems (ROPS) and a seat belt be used. Before beginning operation, clear work area of objects that may be picked up and thrown. Check for ditches, stumps, holes or other obstacles that could upset tractor or damage rotary cutter. Always turn off tractor engine, set parking brake, and allow rotary cutter blades to come to a complete stop before dismounting tractor.

9.1 PREPARING CUTTER FOR OPERATION



DANGER

To help prevent severe injury or death to you or someone else:

- a. Do not engage tractor PTO when cutter is in fully raised position (transport position).
- b. Keep all persons away from machine when raising and lowering cutter.

IMPORTANT! To avoid damaging the machine from impact on ground when lowering, adjust rate at which hitch will lower.

1. Adjust tractor rockshaft rate-of-drop. Allow at least two seconds for machine to lower from full lift height to the ground. *(See your tractor Operator's Manual.)*
2. If equipped, disengage tractor hitch/rockshaft control lever from transport lock position and lower cutter to the ground. *(See your tractor Operator's Manual.)*
3. Adjust tractor lift links to level machine side-to-side. *(See your tractor Operator's Manual.)*
4. Adjust cutting height and angle. *(See Adjusting Cutting Height and Angle in this section.)*

9.2 ADJUSTING CUTTING HEIGHT AND ANGLE



DANGER

Help prevent bodily injury or death caused by entanglement in rotating driveline or blades. Entanglement in rotating driveline or being struck by blades can cause serious injury or death. Before making any adjustments:



- a. Lower machine until rear wheel just touches or is slightly above ground.
 - b. Engage tractor parking brake and/or place transmission in "PARK".
 - c. Disengage PTO.
 - d. Shut off tractor engine and remove key.
 - e. Wait until all moving parts have stopped.
 - f. Disconnect PTO driveline from tractor.
1. Loosen cap screw and lock nut (B), remove cap screw, washers and lock nut (A), raise tailwheel to highest position and install cap screw, washer and lock nut (A).
 2. Using rockshaft control lever, position front of cutter at desired cutting height at location.
 3. Adjust depth stop. *(See your tractor Operator's Manual.)*
 4. Adjust center link so rear of cutter is approximately 2 inches (51 mm.) higher than front.

9 OPERATION (CONTINUED)

NOTE: The rotary cutter should be operated at the highest position which will give optimal cutting results. This will help prevent the blades from striking the ground, reducing blade wear and undue strain on the cutter. For best results under heavier cutting conditions, always tilt the rotary cutter approximately 2 inches (51 mm.) lower in the front. This tilt decreases horsepower requirements and increases potential ground speed. When fine shredding is desired, adjust rotary cutter deck level or slightly lower in the rear. This will keep the foliage under rotary cutter until thoroughly shredded. More power is required for shredding.

5. Lower tailwheel to support rear of the cutter.
6. Install cap screw, washers and lock nut (A) into one of seven holes (C) that aligns with hold in wheel support.
7. Tighten cap screw and lock nut (A).

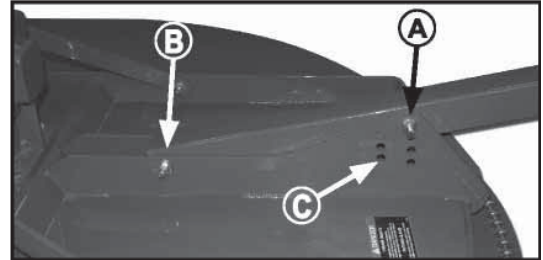

A-B Lock Nut, Washer Cap Screw
C - Adjustment Hole

NOTE: The tailwheel supports the rear of the machine and the draft links support the front to allow the cutter to follow the ground contour.

Each rotary cutter can be adjusted to several cutting heights from 1.5 inches to 9 inches of cutting height by moving the rockshaft control lever in conjunction with moving the tailwheel adjustment bolt among the height adjustment holes (See photo above).

IMPORTANT! Loosening the center link may allow the driveline to contact the cutter frame or tractor tires to contact the foot guards or chain shield. Raise the cutter slowly and check for interference. Lengthen tractor lift links to provide clearance to full height.

NOTE: Lift height may also be limited by installing stops on rockshaft control lever bracket.

8. Lengthen tractor lift links, if necessary, to provide clearance.
9. Adjust tractor center link until bushing is centered in slot, as shown in iMatch Hitch only.

9.3 FOLLOW SAFE OPERATING PROCEDURES

1. Perform BEFORE EACH USE maintenance in the *Lubrication and Maintenance* section.
2. Start tractor per tractor operator's manual.
3. Raise/lower 3-point hitch to place cutter in working position.
4. Look to be sure no one is near cutter.
5. With tractor at idle speed, slowly engage PTO drive



**STAY CLEAR OF ROTATING DRIVELINE.
DO NOT OPERATE WITHOUT DRIVELINE
SHIELDS IN PLACE AND IN GOOD CONDITION.
FAILURE TO HEED THESE WARNINGS MAY
RESULT IN PERSONAL INJURY OR DEATH.**



6. Set tractor throttle for appropriate PTO speed (540 RPM).

9 OPERATION (CONTINUED)

9.3 FOLLOW SAFE OPERATING PROCEDURES (CONTINUED)



ROTATING CUTTER BLADES. STAND CLEAR UNTIL ALL MOTION HAS STOPPED. TO AVOID AN ACCIDENTAL FALL FROM TRACTOR AND POSSIBLE INJURY BY MOWER, IT IS RECOMMENDED THAT TRACTOR BE EQUIPPED WITH ROLLOVER PROTECTIVE SYSTEM (ROPS) AND A SEAT BELT BE USED BY THE OPERATOR FOR ALL MOWING OPERATIONS.

7. Place tractor in gear and proceed forward.

NOTE: Tractor forward speed should be controlled by gear selection, not engine speed. For maximum cutting efficiency, forward speed should allow cutter to maintain a constant, maximum blade speed. If cutter stalls or tractor engine bogs, disengage PTO. Before re-engaging PTO, position cutter in a cut area and reduce tractor throttle to idle. If rotary cutter continuously stalls, select lower gear and/or increase cutting height.



WARNING! ALL ROTARY CUTTERS CAN DISCHARGE OBJECTS AT HIGH SPEEDS WHICH COULD RESULT IN SERIOUS INJURY TO BYSTANDERS OR PASSERS-BY. THEREFORE, THIS CUTTER IS NOT TO BE OPERATED ALONG HIGHWAYS OR IN A NY AREA WHERE PEOPLE MAY BE PRESENT UNLESS ALL SIDES OF THE UNIT ARE ENCLOSED BY PERMANENT BANDS THAT ARE IN GOOD REPAIR.

9.4 KEEP RIDERS OFF MACHINE



Keep riders off. Riders are subject to injury or death such as being struck by foreign objects and being thrown off the machine. Riders may also fall off and be run over by machine. Riders also obstruct the operator's view resulting in the machine being operated in an unsafe manner.



To help prevent severe injury or death to you or someone else:

- NEVER operate cutter when other people are in the vicinity. Debris can be thrown hundreds of feet.
- Keep all shields in place. Including those on discharge opening at front and rear of deck.
- Before starting machine, lower to the ground.
- Engage tractor PTO and gradually increase the speed.
- Operate tractor at rated PTO speed. If engine speed is too slow or too fast, machine may not perform properly.
- Where conditions make it necessary to slow ground speed, shift to a lower gear rather than reducing engine speed. The engine will maintain rated speed and keep cutter running at optimum cutting speed.
- Operate machine from tractor seat only.
- Never adjust machine while in motion.
- Slow down when turning or traveling over rough ground.
- Avoid holes when operating on hillsides. Tractor roll-over could result.
- Shut off tractor engine and engage tractor parking brake and/or place transmission in "Park" when leaving tractor. Remove key when leaving tractor unattended.
- Components behind shields may rotate several minutes after power is shut off. Look and listen for evidence of rotation before removing shielding.

10 LUBRICATION AND MAINTENANCE

10.1 LUBRICATING AND MAINTAINING MACHINE SAFELY



Help prevent bodily injury or death caused by entanglement in rotating driveline or blades. Entanglement in rotating driveline or being struck by blades can cause serious injury or death.

Components will be hot after operation. Let all components cool before servicing.

Replace all shields after lubricating or servicing.

10.2 MAINTENANCE CHECK LIST

Perform scheduled maintenance as outlined below:

- Lower machine to ground, turn off tractor and set parking brake before doing maintenance inspections or work.
- All bolts should be torqued as recommended in the *Torque Specifications* unless otherwise indicated.

10.3 MAINTENANCE BEFORE EACH USE



CAUTION! Do not clean, lubricate, or adjust machine while it is in motion.

1. Check tractor tire air pressure. Refer to tractor *Operator's Manual*.
2. Check blades and spindles to be sure that no foreign objects such as wire or steel strapping bands are wrapped around them.
3. Check blade bolts for tightness.
(Tighten to 425 ft./lbs.)

IMPORTANT! Operating with loose blade hardware will damage the blade holder and blades.

- a. Remove tailwheel tube assembly support. (See *Removing and Installing Tailwheel Support in Service Section*.)
- b. Locate blade hardware under hole.

Note: Blade bolt tightening requires a 1 1/2" socket with extension, a torque multiplier, and a torque wrench to torque nut to 425 ft./lbs.

- c. Reinstall tailwheel tube assembly support in original position.

4. Inspect blades for wear. (See *Service Section Checking Blade Wear*). Always replace both blades on blade holder with genuine parts.
5. Make certain driveline shields are in place and in good repair.
6. Inspect tailwheel for wear, damage, or foreign objects. (Repair or replace if necessary.)
7. Before each use refer to *Lubrication Locations and Intervals* in this section.
8. During operation, listen for abnormal sounds which might indicate loose part, damaged bearings, or other damage.

10.4 MAINTENANCE AFTER EACH USE

1. Clean all debris from rotary cutter especially under side of deck. When cleaning underside of deck, securely block machine into position.

IMPORTANT! To help prevent structural damage caused by loose hardware, check all hardware after first eight (8) hours of use and tighten all hardware to specifications.

10.5 OBSERVE LUBRICATION SYMBOLS

Lubricate with John Deere SD POLYUREA GREASE or equivalent SAE multipurpose type grease (unless otherwise specified) at hourly intervals indicated on the symbols.



10 LUBRICATION AND MAINTENANCE (CONTINUED)

10.6 LUBRICATION BEFORE EACH USE

1. Driveline Universal Joints

- a. Apply multi-purpose grease with a grease gun.

2. Driveline Guard

- b. Apply 2 - 3 shots of multi-purpose grease with grease gun to plastic fitting.

3. Driveline Profile

- c. Disconnect PTO driveline.
- d. Pull two sections apart.
- e. Apply thin coat of multi-purpose grease to inside of female section.
- f. Re-assemble sections.

Note: Pull each section to be sure driveline and shields are securely connected. Make certain PTO shielding is in good condition. Do not grease outer or inner plastic shields.

4. Tailwheel Pivot Tube

- g. Apply multi-purpose grease with grease gun.

5. Tailwheel

- h. Apply multi-purpose grease with grease gun.

6. Gearbox

- i. Check oil level by removing oil level check plug on side of gearbox.
- j. Add EP80-90W gear oil if necessary to bring oil level to check plug hole.

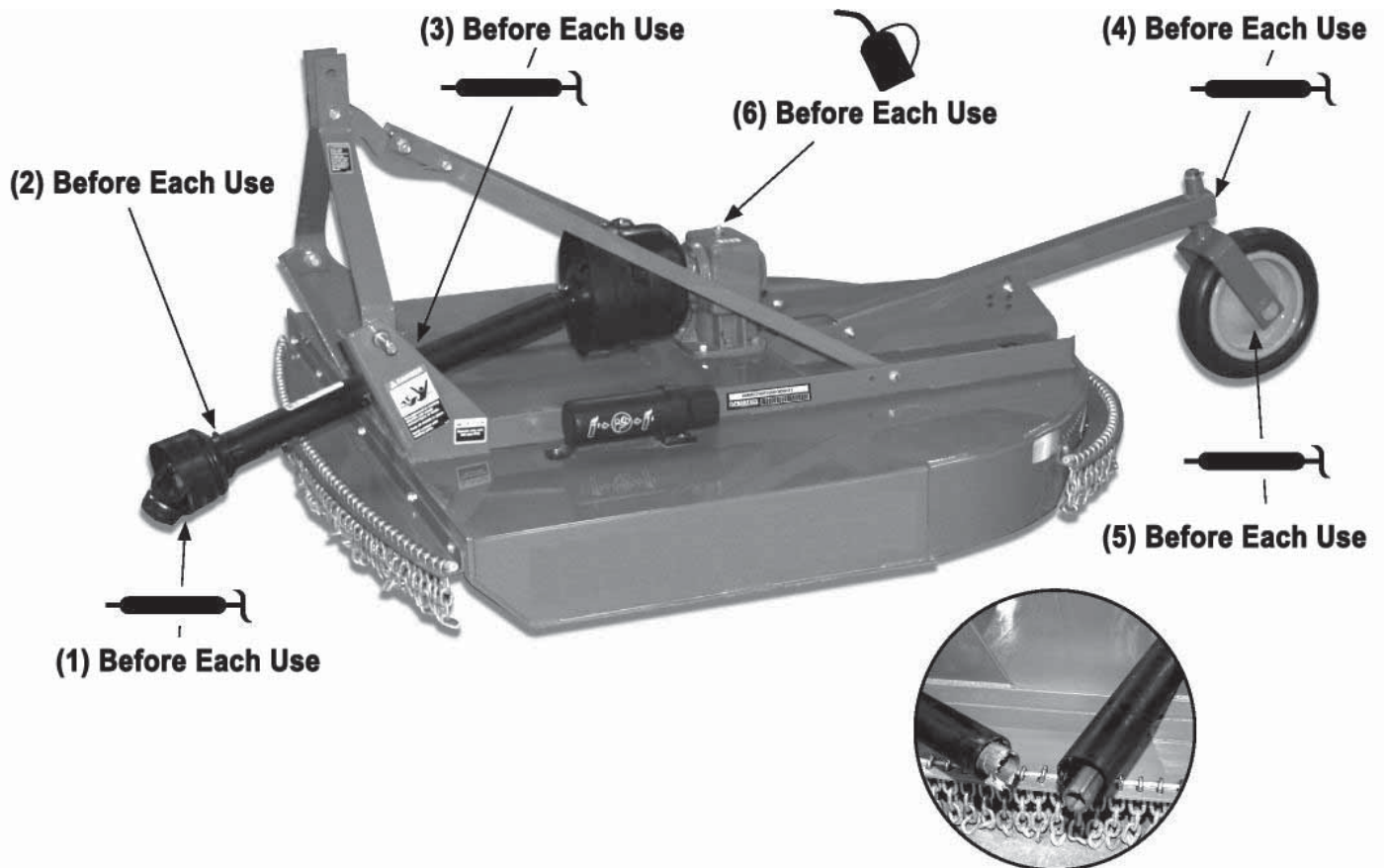

- d. Pull two sections apart.

11.1 PRACTICE SAFE SERVICE PROCEDURES



CAUTION! To help prevent personal injury caused by unexpected movement, be sure to service machine on a level surface.

Before servicing or adjusting machine connected to a tractor:

1. Lower machine to the ground.
2. Engage tractor parking brake and/or place transmission in "Park".
3. Disengage PTO.
4. Shut off tractor engine and remove key.
5. Wait until all moving parts have stopped.
6. Disconnect PTO driveline from tractor.

The blades and blade holder may rotate for several minutes after PTO is shut off. Look and listen for rotating driveline to stop before working on the cutter.

When servicing blades or blade holder, it will be necessary to work underneath cutter. Be sure to support cutter frame at all four corner locations with safety shop stands to prevent accidental lowering. Do not position safety stands under wheel support because these components can rotate.

11.2 DISASSEMBLING AND ASSEMBLING DRIVELINE SHIELDS

1. Separate telescoping parts.
2. Remove driveline shield screw (B).
3. Rotate cone to align tab (C) with hole (A) and slide shield rearward off of driveline.

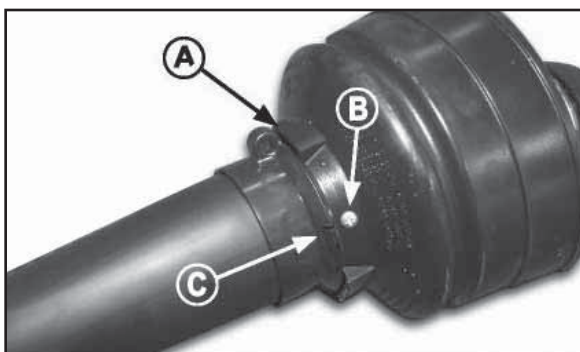

4. Assemble in reverse order.

11.3 DISASSEMBLING AND INSPECTING SLIP CLUTCH

1. Remove slip clutch driveline. (*See procedure in this section.*)

NOTE: Belleville springs, which are part of the clutch, keep tension on all components. When disassembling, release tension by loosening hardware progressively.

2. Loosen bolts and lock nuts progressively until tension is relieved.
3. Friction disks may appear to be part of the hub or yoke, tap lightly on edge to separate.
4. Inspect clutch components for wear or damage. Repair or replace parts as necessary.

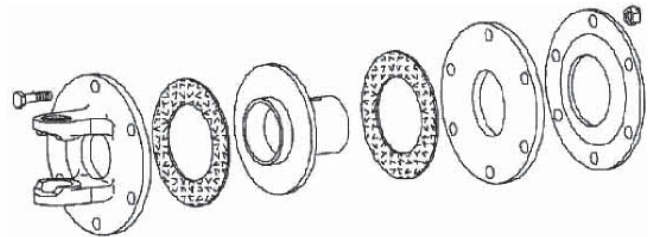

11.4 ASSEMBLING SLIP CLUTCH

Assemble slip clutch in reverse order of disassembly using the following instructions:

1. Install belleville spring with concave side facing away from yoke end.

IMPORTANT! To avoid driveline damage, DO NOT overtighten bolts and lock nuts. A gap must be left between clutch plate (B) and belleville spring (C).

2. Tighten bolts and lock nuts progressively, leaving a gap (A) 4 mm, between clutch plate (B) and belleville spring (C).

11 SERVICE (CONTINUED)

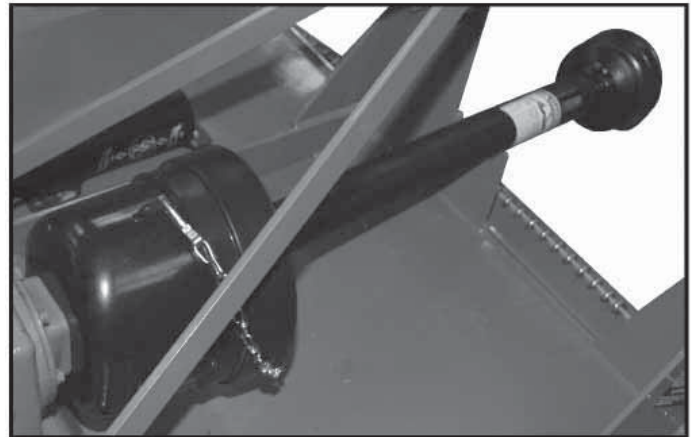
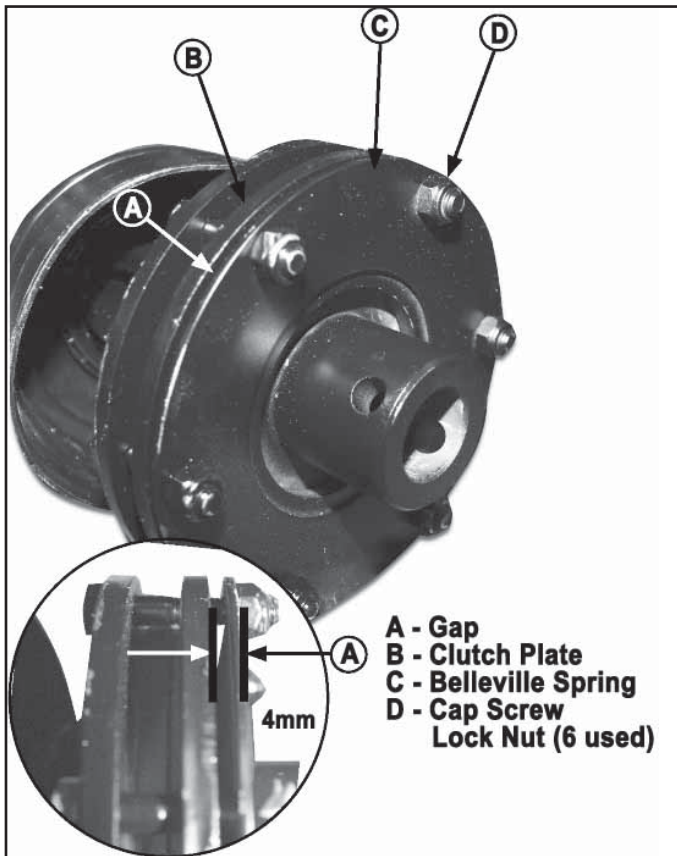

(Disconnect driveline shield chain)

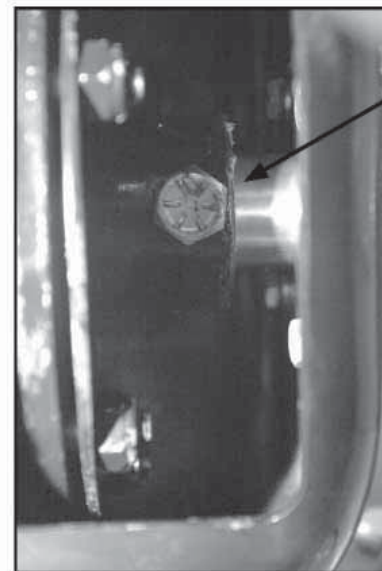

1/2" x 3"
Gr. 8 bolt

11.5 REMOVING AND INSTALLING DRIVELINE SLIP CLUTCH

1. Disconnect driveline shield chain.
2. Open access panel on shield.
3. Remove driveline assembly from gearbox output shaft by removing 1/2" x 3" Grade 8 bolt and lock nut.
4. Make repairs as necessary:
 - a. Slip clutch service - See *Disassembling and Inspecting Slip Clutch* in this section.
 - b. Driveline repair - see your Gearmore dealer.

IMPORTANT! Apply multi-purpose grease on gearbox input shaft. 1/2" x 3" Grade 8 bolt and lock nut required to attach driveline to gearbox input shaft.

5. Install driveline in reverse order of removal.

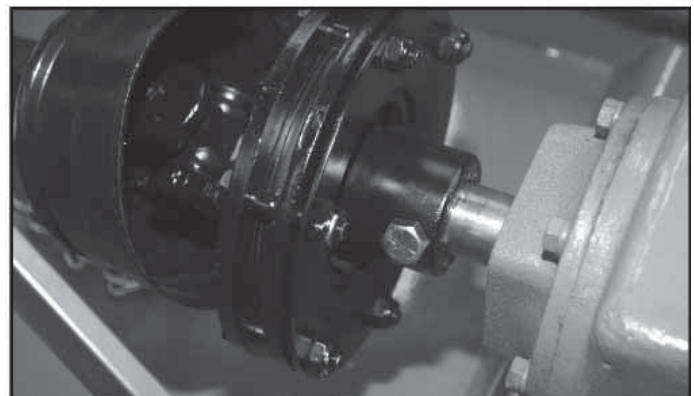

NOTE: Slip clutch shield removed for illustration purposes.

11.6 REMOVING AND INSTALLING DRIVELINE SHEAR BOLT

1. Disconnect driveline shield chain.
2. Bend back driveline shield cone.
3. Remove shear bolt and lock nut.
4. Push driveline onto input shaft toward gearbox and remove snap ring.
5. Pull driveline from gearbox shaft.
6. Replace or repair as necessary.
7. Install in reverse order of removal.

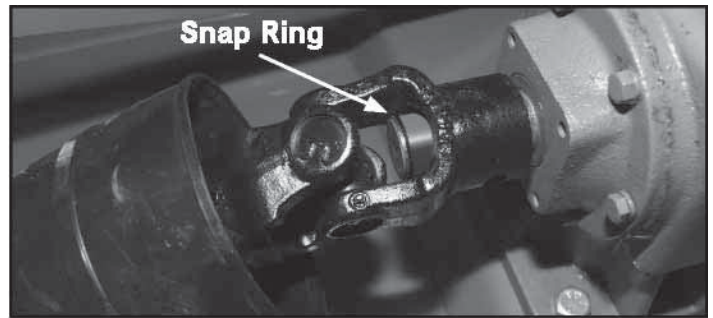

11.7 REPLACING DRIVELINE SHEAR BOLT

IMPORTANT! Avoid shear bolt failure at start up by engaging the PTO slowly at low engine RPM.

If shear bolt fails:

1. Bend back driveline shield cone.
2. If necessary remove sheared bolt with hammer and punch and realign holes in yoke and shaft.
3. Replace with ½" x 3" Gr. 2 bolt and lock nut.

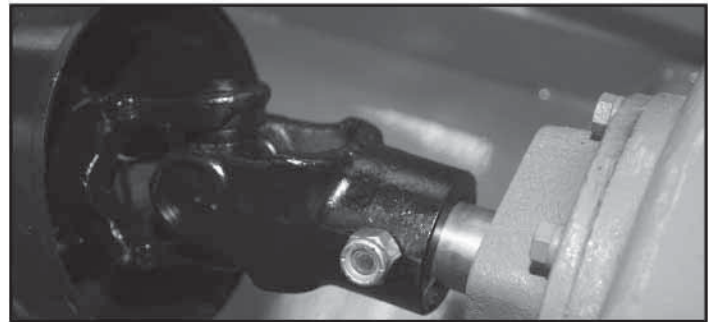

NOTE: Driveline shield pulled back for illustration purposes. Cutter drive components are protected from shock loads by a shear bolt.

11.8 REMOVING AND INSTALLING TAILWHEEL SUPPORT



CAUTION! When removing and installing tailwheel support, it will be necessary to support the cutter. Before servicing cutter, refer to **PRACTICE SAFE SERVICE PROCEDURES** at the beginning of this section.

1. Remove ½" lock nut, washers and ½" x 4" bolt (A).
2. Remove tailwheel support
3. Install tailwheel support in reverse order.

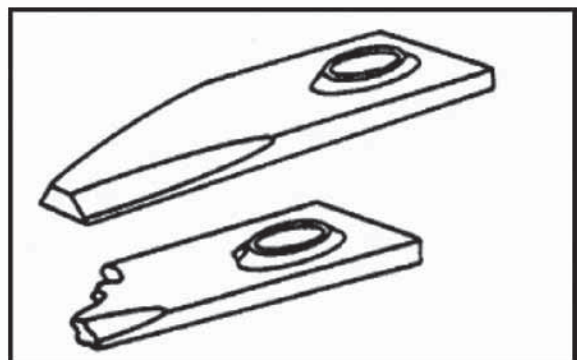
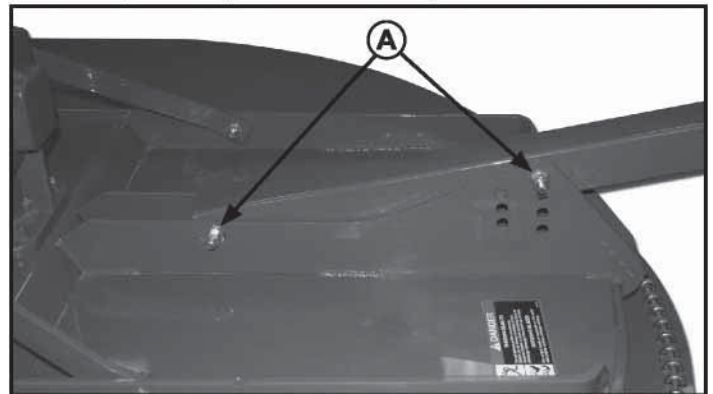

11.9 CHECKING BLADE WEAR

IMPORTANT! Operating with blades that are not alike will cause vibration. Always replace worn or broken blades in pairs. Never replace a single blade. Check blades regularly for wear or breakage.

11 SERVICE (CONTINUED)

11.10 REPLACING BLADES

IMPORTANT! Operating with loose blade hardware will damage the blade holder and blades. Whenever the blades have been removed or replaced, blade hardware **MUST** also be replaced. Always use genuine parts. Check blade hardware torque after one hour of operation and every eight (8) hours thereafter.

NOTE: Suction blades have cutting edge on one side only. Note blade rotation when installing blades. (See DIRECTION OF BLADE ROTATION in this section.)

Tailwheel support must be removed to locate blade access hole.

1. Remove tailwheel support. (See *REMOVING AND INSTALLING TAILWHEEL SUPPORT* in this section.)
2. Manually rotate driveline to align lock nut with access hole in top of deck. Discard mounting hardware.
3. Install new hardware and tighten lock nut to 425 ft./lbs.
4. Install tailwheel support.

11.11 DIRECTION OF BLADE ROTATION

IMPORTANT! Cutter shown is viewed from the top. Take special note of blade rotation shown by the arrow.

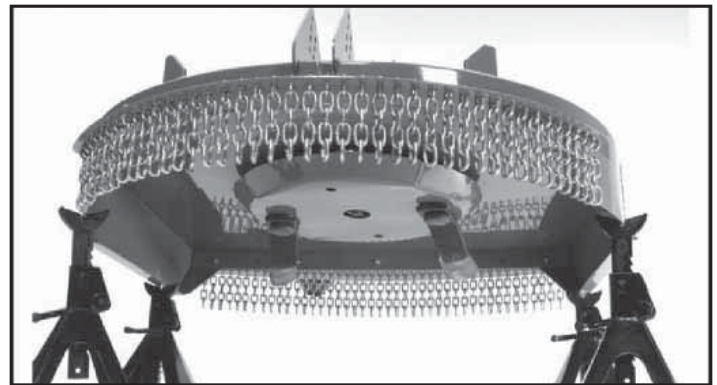
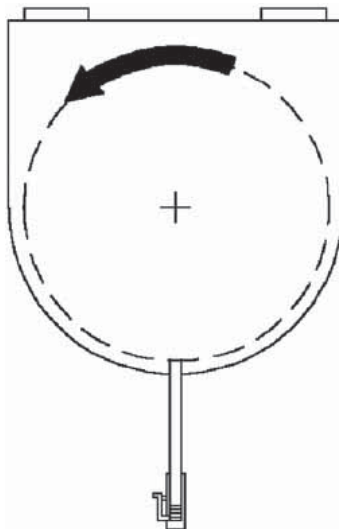

CAUTION! When replacing blades, blade hardware and blade pan, it will be necessary to work underneath cutter. Be sure to support cutter frame at all four corner locations with safety shop stands to prevent accidental lowering. Do not position safety stands under wheel support because these components can rotate.

11 SERVICE (CONTINUED)

11.12 REPLACING BLADE PAN

1. Remove the blades. (See *Replacing Blades in this section.*)
2. Remove cotter pin from output shaft of the gearbox.
3. Loosen castle nut to the bottom of the output shaft (A). Do not remove castle nut as it must hold the blade pan when it becomes loose.
4. Tap with a hammer around the hub using a block of wood as shown in photo.

NOTE: The output shaft of the gearbox is tapered. A few taps around the hub will loosen the blade pan.

5. Remove castle nut slowly and allow the blade pan to be removed.
6. Remove blade pan.

7. To reinstall blade pan, reverse the above steps. Be sure to tighten the castle nut and replace the cotter pin.
8. Replace blades. (See *Replacing Blades in this section.*)

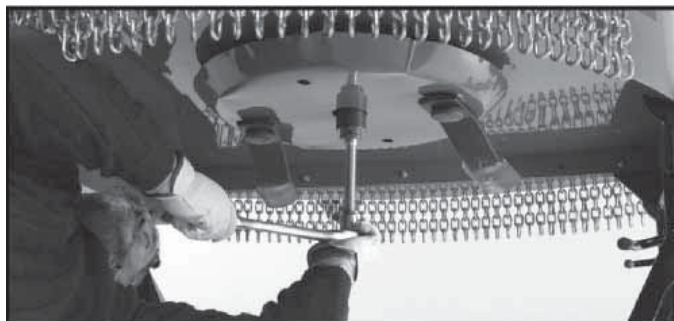
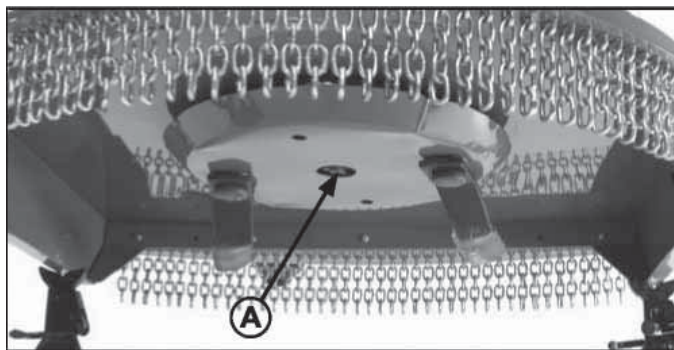

11.13 REPLACING TAILWHEEL PIVOT/SPINDLE

1. Remove ½" lock nut, washer and ½" x 4" bolt.
2. Raise tailwheel to highest position and replace hardware.
3. Remove roll pin and washer (A).
4. Slide tailwheel assembly out of tailwheel support tube.

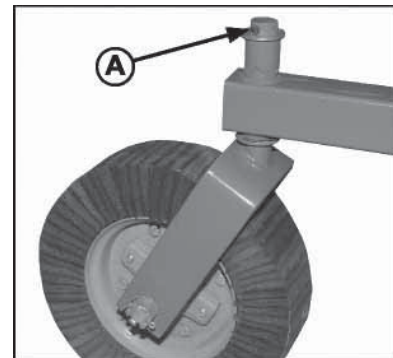

12.1 AT THE END CUTTING SEASON

1. Drain and change the oil in the gearbox.
2. Check (and replace where necessary) blades, bolts, and nuts on the cutter.
3. Clean cutter and touch up any rust spots that may have appeared.

4. Replace any safety decals if damaged.
5. Store rotary cutter in a clean dry location.
6. Do not let children play on or around stored machine.

12 STORAGE

13 ASSEMBLY

13.1 PERFORM PREDELIVERY SERVICE SAFELY



CAUTION! Understand the predelivery procedure before doing the work.

During the assembly, test, and adjustment procedures, it may be necessary to operate drives and hydraulic systems. Stay clear of machine elements when raising or lowering machine and during operation of drivelines.

Practice good communication with other service technicians. Be aware of their actions and alert them to potential hazards.

Never lubricate, service, or adjust machine while it is running. Keep hands, feet, and clothing away from power-driven or hydraulically operated parts. If it is necessary to inspect the machine while it is in operation, be alert to moving parts in the immediate area.

13.2 REMOVE SHIPPING DUNNAGE AND PARTS



To help prevent bodily injury from accidental lowering of the cutter, attach a lifting strap or chains to cutter rear support frame and a hoist.

1. Remove loose parts attached to the cutter on the underside of the deck.
2. Wrap lifting strap or chains around cutter rear support frame and attach to a hoist.
3. Lower machine onto 4 inch wood blocks.
4. Remove all shipping bands, wires and loose parts from around the cutter.
5. Remove shipping stands from cutter by removing hitch pins (A) and ½" bolts (B). Discard shipping stands and ½" bolts.
6. Install hitch pins and tighten to specified torque.

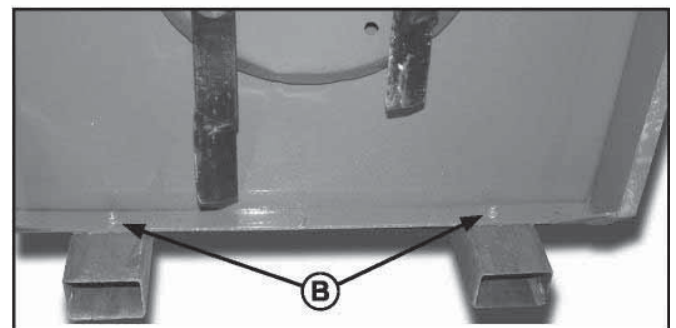

13 ASSEMBLY (CONTINUED)

13.3 ASSEMBLE HITCH

1. Rotate hitch up.

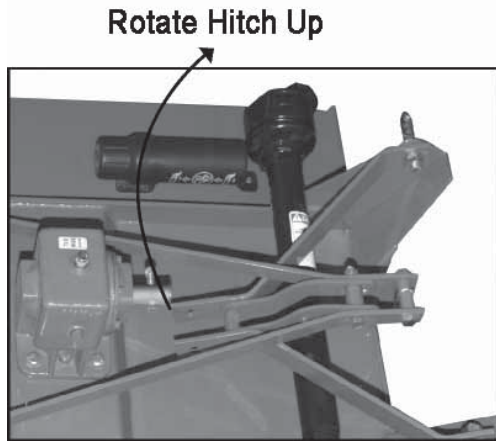

2. Attach brace to frame using $\frac{1}{2}$ " x $1\frac{3}{4}$ " bolt, bushing, washer and lock nut.
 - a. **Match Quick Hitch**
Install bolt, bushing, and lock nut into hole and tighten to specifications.
 - b. **Non-Match Quick Hitch**
Install bolt, bushing, and lock nut into hole and tighten to specifications.

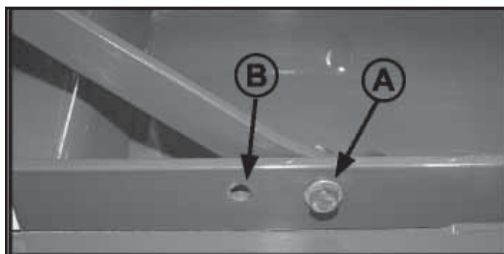

3. Repeat on opposite brace.
4. Tighten all link and brace hardware (A).
5. Attach lift arm brace (A) to frame using $\frac{1}{2}$ " x $1\frac{3}{4}$ " bolt (C), bushing (B), flat washer (E), and lock nut (D). Tighten bolt to specifications.

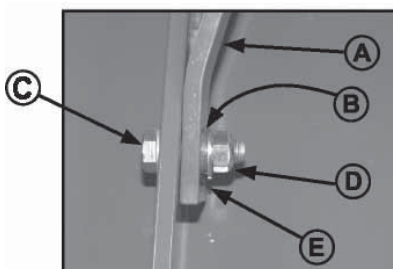

- A - Brace
- B - Bushing
- C - $\frac{1}{2}$ " x $1\frac{3}{4}$ " bolt Gr. 5
- D - Lock Nut
- E - Washer

6. Repeat on opposite brace.
7. Tighten all link and brace hardware (A).

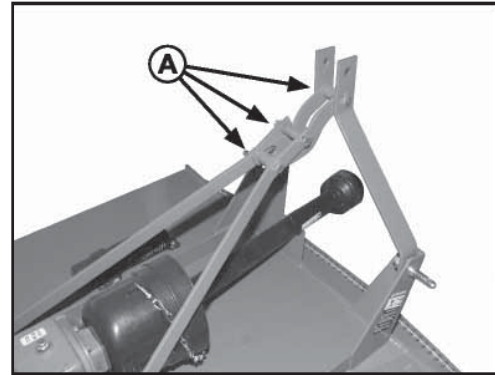

Match Quick Hitch

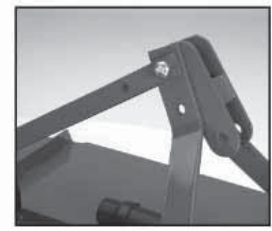

Non-Match Quick Hitch

13.4 INSTALL TAILWHEEL SUPPORT

1. If necessary remove tailwheel support from shipping position.
2. Place tailwheel support between brackets on deck.
3. Install $\frac{1}{2}$ " x 4" bolt, washers and lock nut (A).
4. Install $\frac{1}{2}$ " x 4" bolt, and lock nut (C) into one of seven holes (B) that aligns with hole in wheel support. (See *Adjusting Cutting Height and Angle in Operation the Cutter section.*)
5. Tighten hardware.

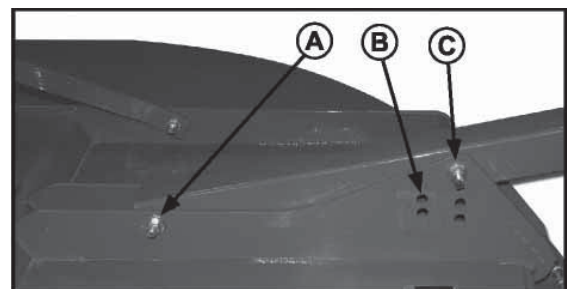

13 ASSEMBLY (CONTINUED)

13.5 INSTALL TAILWHEEL

1. If necessary, attach using axle bolt, washer, castle nut, washers, and cotter pin.
2. Tighten hardware.

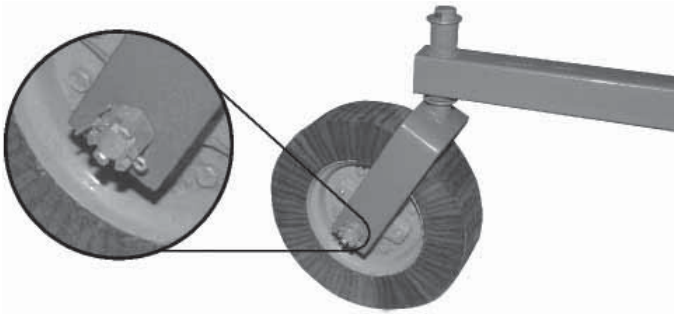

13.6 INSTALL DRIVELINE

1. Remove snap ring and shear bolt from gearbox input shaft.
2. Remove paint from gearbox input shaft.
3. Install slip clutch shield (if equipped).
 - a. Open access panel on shield.
 - b. Attach shield to gearbox using four $\frac{5}{16}$ " x $\frac{3}{4}$ " bolt Grade 2 and flat washers. Tighten to specifications.
4. Install driveline. (See *REMOVING AND INSTALLING DRIVELINE* in *Service section*.)

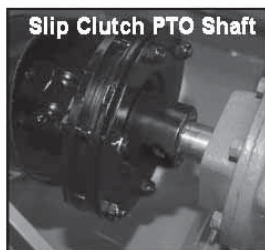
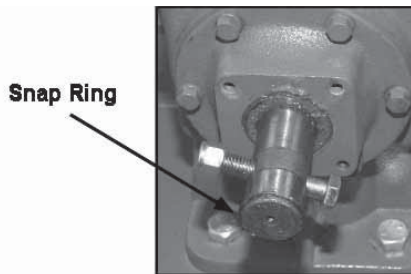

NOTE: Driveline shield pulled back for illustration purposes.

13.7 FILL GEARBOX

IMPORTANT! Cutter is shipped without gearbox lubricant. **DO NOT** operate the cutter without filling gearbox with specified amount of lubricant listed below, or gearbox will be damaged. (See *Lubrication and Maintenance section*.)

1. Remove air vent plug (A) from filler hole.
2. Fill gearbox according to initial fill with 32 ounces of EP80W-90 gear oil.

IMPORTANT! Oil will move into lower cavity of gearbox during initial operation. Check oil level after 30 minute break-in period and before every use.

3. After approximately 30 minutes of initial operation, remove check plug (B) and check oil level. Oil should just seep from check plug hole.
4. Add oil if necessary and replace plug (A).

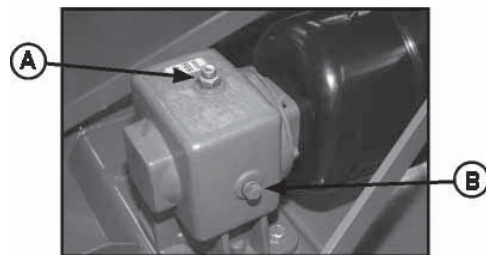

A - Breather Plug
B - check Plug

13.8 INSTALL FRONT DEFLECTOR-CHAINS (IF EQUIPPED)

IMPORTANT! Install hardware with lock nuts and flat washers on the outside of cutter.

1. Install deflector using provided bolts, flat washers, lock washer, and lock nuts. Insert bolts and flat washer from inside out of rotary cutter. Tighten hardware to specifications in torque chart.



13 ASSEMBLY (CONTINUED)

13.9 INSTALL FRONT DEFLECTOR - RUBBER (IF EQUIPPED)

IMPORTANT! Install hardware with lock nuts and flat washers on the outside of cutter.

1. Install deflector using two (2) foot guards (*See INSTALL FOOT GUARDS in this section*) and provided bolts, flat washers, lock washers, and lock nuts. Insert bolts and flat washer from inside out of rotary cutter.
2. Start with holes closest to center of machine and work towards outside edge of the rotary cutter, inserting bolts and flat washers.
3. For best results, stretch rubber towards outside edge of rotary cutters as nuts are tightened.

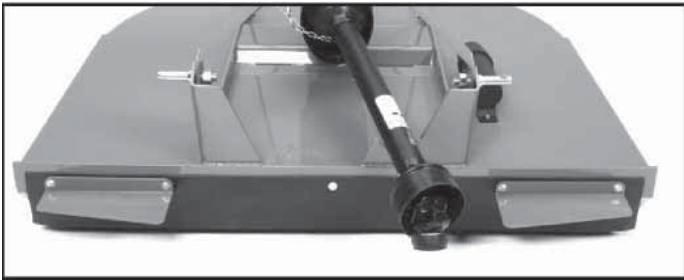

13.10 INSTALL FOOT GUARDS (IF EQUIPPED)

NOTE: Foot guards are also used with rubber front safety shield.

IMPORTANT! Install hardware with lock nuts and flat washers on the outside of cutter.

1. Install guards on each side of machine with long leg toward center of cutter and fasten with the two (2) bolts, flat washers, lock washers, and lock nuts provided per guard. Insert bolts and flat washer from inside out of rotary cutter. Tighten hardware to specifications in torque chart.

13.11 INSTALL REAR DEFLECTOR - CHAINS (IF EQUIPPED)



IMPORTANT! Install hardware with lock nuts and flat washers on the outside of cutter.

1. Install deflector using provided bolts, flat washers, lock washer, and lock nuts. Insert bolts and flat washer from inside out of rotary cutter. Tighten hardware to specifications in torque chart.

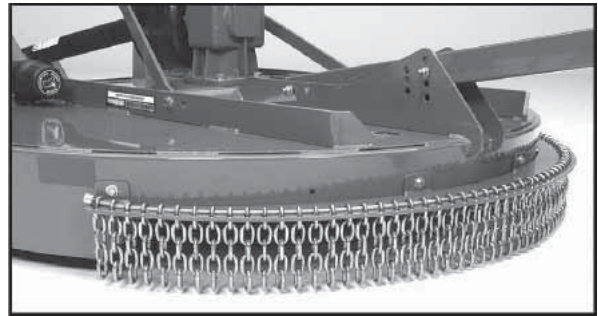

13.12 INSTALL REAR DEFLECTOR - RUBBER (IF EQUIPPED)

IMPORTANT! Install hardware with lock nuts and flat washers on the outside of cutter.

1. Install deflector 3 metal bands and provided bolts, flat washers, lock washers, and lock nuts. Insert bolts and flat washer from inside out of rotary cutter.
2. Start with holes closest to center of machine and work towards outside edge of the rotary cutter, inserting bolts and flat washers.
3. For best results, stretch rubber towards outside edge of rotary cutters as locknuts are tightened. Tighten hardware to specifications in torque chart.
4. RC200-72 only - Install bolts, washers, lock washers and lock nuts in holes between the outside metal bands and the inside metal bands with bolt head and lock washers on inside of cutter and flat washer and lock nut on outside of cutter.



13 ASSEMBLY (CONTINUED)

13.13 FINAL INSPECTION AND ADJUSTMENTS

IMPORTANT! PTO driveline may be too long for some tractor models, causing tractor transaxle damage. Modify driveline if necessary.

Attach rotary cutter to tractor and check cutter-tractor driveline telescoping length clearance. (See *CHECKING DRIVELINE/CUTTER CLEARANCE* in *Attaching section*.)

IMPORTANT! Blade hardware **MUST** be checked after the first hour and every eight (8) hours thereafter.

Check blade hardware torque. Re-tighten hardware after one hour of operation and every eight (8) hours thereafter. (See *TIGHTENING BLADE HARDWARE* in *Lubrication and Maintenance section*.)

13.14 MODIFY PTO DRIVELINE (IF NECESSARY)

1. To adjust the length, hold the half-shafts next to each other in the shortest working position and mark them.

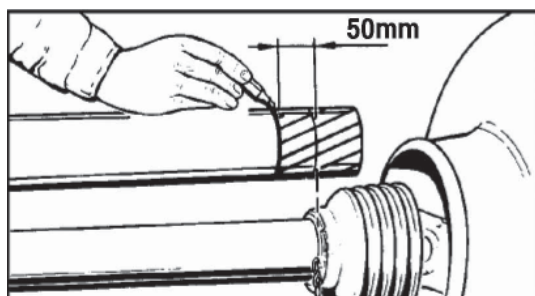

2. Shorten inner and outer guard tubes equally.

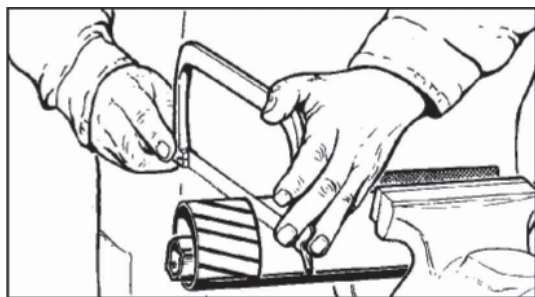

3. Shorten inner and outer sliding profiles by the same length as the guard tubes.

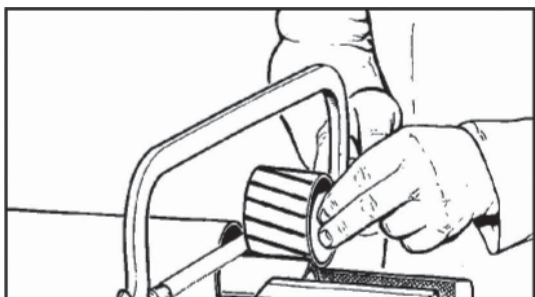

4. Round off all sharp edges and remove burrs. Grease sliding profiles. No other changes may be made to PTO driveshaft and guard.

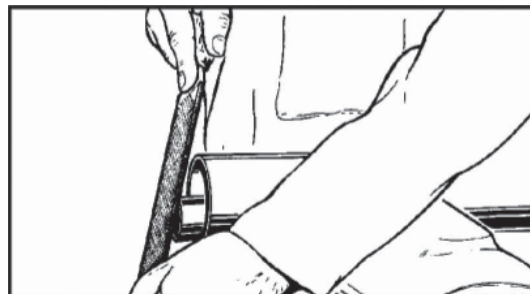

5. Chains must be fitted so as to allow sufficient articulation of the shaft in all working positions.

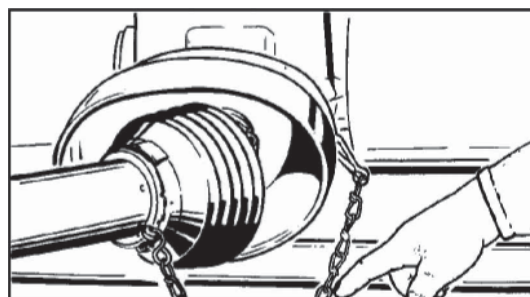

6. The PTO driveshaft must not be suspended from the chains!

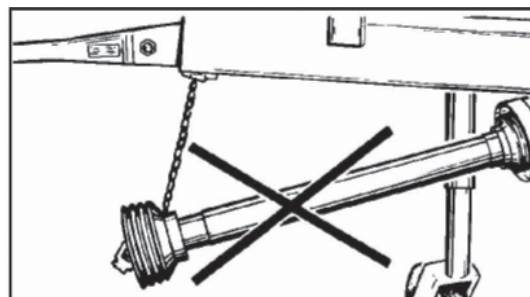

14 TORQUE SPECIFICATIONS

AMERICAN Bolt Head Markings



SAE Grade 2
(No Dashes)



SAE Grade 5
(3 Dashes)

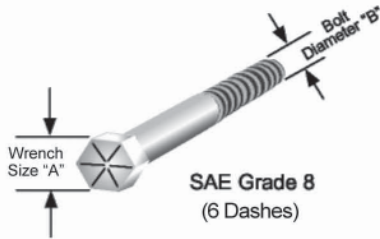

SAE Grade 8
(6 Dashes)

Proper torque for American fasteners used on manufactured implement.
Recommended Torque in Foot Pounds (Newton Meters).*

WRENCH SIZE (IN.) "A"	BOLT DIAMETER (IN.) "B" AND THREAD SIZE	SAE GRADE 2	SAE GRADE 5	SAE GRADE 8
7/16	1/4 -20 UNC	6 (7)	8 (11)	12 (16)
7/16	1/4 - 24 UN [~]	6 (8)	10 (13)	14 (18)
1/2	5/16 -18 UNC	11 (15)	17 (23)	25 (33)
1/2	5/16 - 24 UN [~]	13 (17)	19 (26)	27 (37)
9/16	3/8 - 16 UNC	20 (27)	31 (42)	44 (60)
9/16	3/8 -24 UN [~]	23 (31)	35 (47)	49 (66)
5/8	7/16 -14 UNC	32 (43)	49 (66)	70 (95)
5/8	7/16 - 20 UN [~]	36 (49)	55 (75)	78 (106)
3/4	1/2 - 13 UNC	49 (66)	76 (103)	106 (144)
3/4	1/2 - 20 UN [~]	55 (75)	85 (115)	120 (163)
7/8	9/16 -12 UNC	70 (95)	109 (148)	153 (207)
7/8	9/16 - 18 UN [~]	79 (107)	122 (165)	172 (233)
15/16	5/8 - 11 UNC	97 (131)	150 (203)	212 (287)
15/16	5/8 - 18 UN [~]	110 (149)	170 (230)	240 (325)
1-1/8	3/4 - 10 UNC	144(195)	266 (360)	376 (509)
1-1/8	3/4 - 16 UN [~]	192 (260)	297 (406)	420 (569)
1-5/16	7/8 - 9 UNC	166 (225)	430 (583)	606 (821)
1-5/16	7/8 - 14 UN [~]	184 (249)	474 (642)	668 (905)
1-1/2	1-8 UNC	250 (339)	644 (873)	909 (1232)
1-1/2	1 - 12 UN [~]	274 (371)	705 (955)	995 (1348)
1-1/2	1-14 UN [~]	280 (379)	721 (977)	1019 (1381)
1-11/16	1-1/8 - 7 UNC	354 (480)	795 (1077)	1288 (1745)
1-11/16	1-1/8 -12 UN [~]	397 (538)	890 (1206)	1444 (1957)
1-7/8	1-1/4 - 7 UNC	500 (678)	1120 (1518)	1817 (2462)
1-7/8	1-1/4 - 12 UN [~]	553 (749)	1241 (1682)	2013 (2728)
2-1/16	1-3/8 - 6 UNC	655 (887)	1470 (1992)	2382 (3228)
2-1/16	1-3/8 -12 UN [~]	746 (1011)	1672 (2266)	2712 (3675)
2-1/4	1-1/2 - 6 UNC	870 (1179)	1950 (2642)	3161 (4283)
2-1/4	1-1/2 - 12 UN [~]	979 (1327)	2194 (2973)	3557 (4820)

METRIC

Proper torque for metric fasteners used on manufacturer implement.
Recommended Torque in Foot Pounds (Newton Meters).*

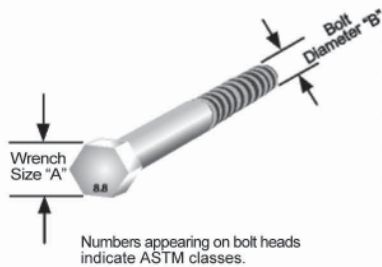

Numbers appearing on bolt heads indicate ASTM classes.

WRENCH SIZE (mm) "A"	BOLT DIA. (mm) "B"	ASTM 4.6	ASTM 8.8	ASTM 9.8	ASTM 10.9
8	5	1.8 (2.4)		5.1 (6.9)	6.5 (8.8)
10	6	3 (4)		8.7 (12)	11.1 (15)
13	8	7.3 (10)		21.1 (29)	27 (37)
16	10	14.5 (20)		42 (57)	53 (72)
18	12	25 (34)	74 (100)	73 (99)	93 (126)
21	14	40 (54)	118 (160)	116 (157)	148 (201)
24	16	62 (84)	167 (226)	181 (245)	230 (312)
30	20	122 (165)	325 (440)		449 (608)
33	22		443 (600)		611 (828)
36	24	211 (286)	563 (763)		778 (1054)
41	27		821 (1112)		138(1542)
46	30	418 (566)	1119 (1516)		1547(2096)

*Use 75% of the specified torque value for plated fasteners. Use 85% of the specified torque values for lubricated fasteners.

15 TROUBLESHOOTING GUIDE

PROBLEM	POSSIBLE CAUSE	POSSIBLE REMEDY
Leaves a streak of uncut or partially cut grass.	Rotary cutter not level, side to side. Blade dull or bent. Blades unable to cut that part of grass pressed by path of tractor tires. Possible build up of material under rotary cutter.	Level 3-pt. hitch linkage on tractor. Sharpen or replace blades. Slow ground speed of tractor but keep engine running at full PTO rpm. Cutting lower will help. Clean rotary cutter.
Blade cuts grass lower in center of swath than at the edge.	Height of rotary cutter lower at rear or at front.	Adjust rotary cutter height and altitude so that rotary cutter rear and front are within ½" of same height.
Material discharges from cutter unevenly, or discharges clumps of grass.	Grass or brush may be too high or thick. Grass wet.	Reduce ground speed but maintain 540 rpm at tractor PTO, or make two passes over material. Raise rotary cutter for the first pass and lower for the second pass, preferably cutting 90° to the first pass. Raise rear of rotary cutter high enough to permit material to discharge. Allow grass to dry before mowing. Slow ground speed of tractor but keep engine running at full PTO rpm. Cutting lower will help.
Gearbox overheating.	Low on lubricant. Improper lubricant type. Excessive trash build up around gearbox.	Fill to proper level. Replace with proper lubricant. Remove trash.
Rotary cutter will not cut. Rotary cutter will not cut all the time (slip clutch only).	Shear bolt sheared. Slip clutch slipping.	Install new shear bolt. Adjust slip clutch according to guidelines in Service section.
Excessive vibration.	Possible build up of material on blade. Blades locked into position. Check for even wear on each blade tip. Broken blade. New blade or bolts not matched with worn blade or bolts.	Clean blade pan. Free blades so they swing free. Weigh each blade. Weight should be within 1 oz. Always replace both blades. Replace blades in sets. Replace blades or bolts in sets.
Gearbox noisy.	Low oil in gearbox.	Check oil level. Add oil.

16.1 PARTS OVERALL VIEW

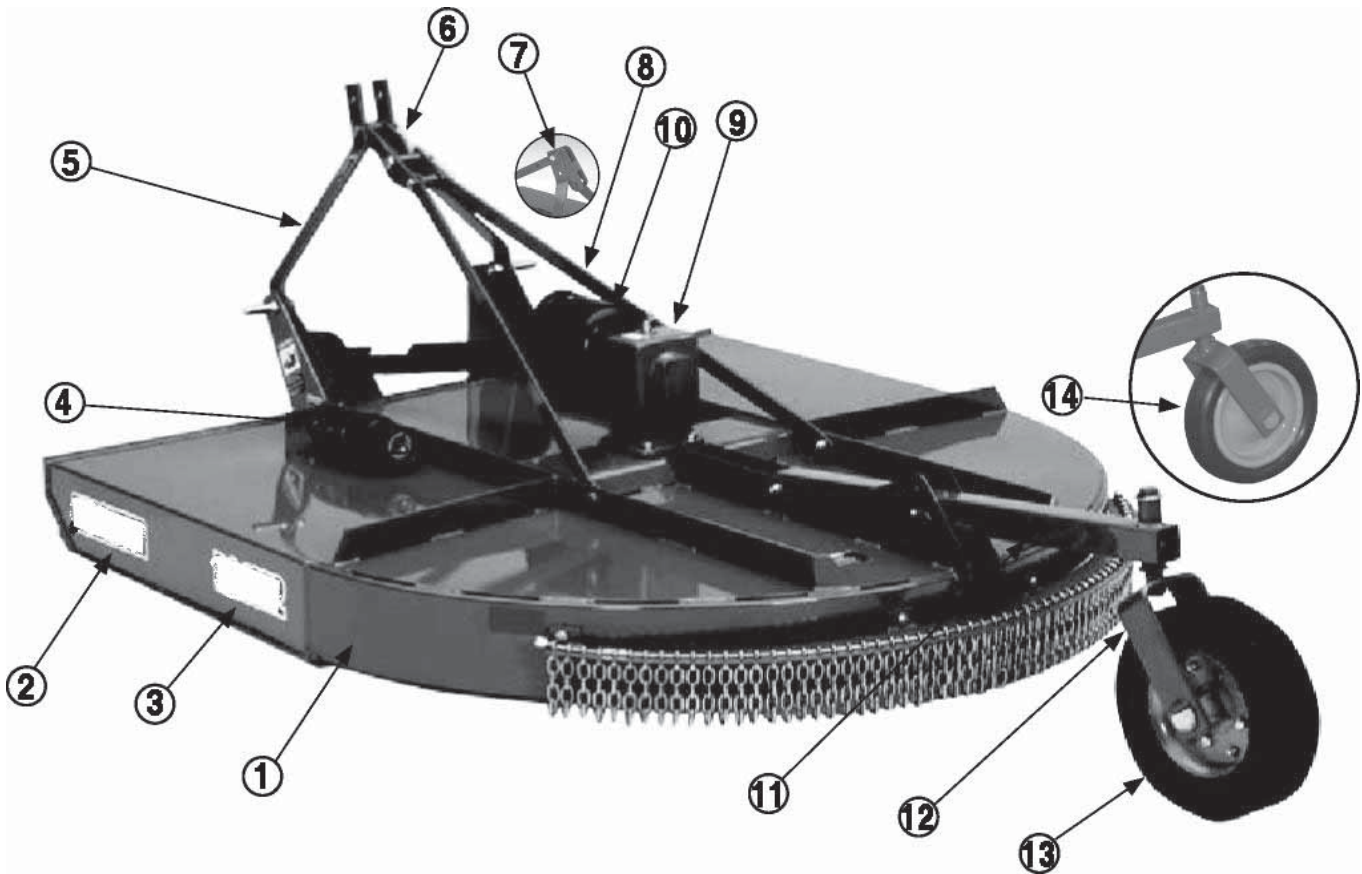

<u>REF. NO.</u>	<u>QTY.</u>	<u>PART NO.</u>	<u>DESCRIPTION</u>
1	1	N/A	Deck Assembly
2	2	101560	Logo Decal
3	2	101561	Model Number Decal (RC200-48)
3	2	101562	Model Number Decal (RC200-60)
3	2	101563	Model Number Decal (RC200-72)
4	1	100165	Manual Tube
5	1	300278	Top Link Mount
6	1	301277	Match Pivot Link Kit
7	1	300278	Non-Match Link Kit
8	2	301283	Lift Strap RC200-48 & RC200-60
8	2	301284	Lift Strap RC200-72
9	1	300209	RC200-48 Gearbox 45 HP
9	1	300210	RC200-60 & RC200-72 Gearbox 65 HP
10	1	300211	Slip Clutch Shield Cone
11	1	300290	Tailwheel Tube Assembly
12	1	300109	Tailwheel Fork
13	1	300127	Laminated Tailwheel
14	1	300238	Solid Rubber Tire Tailwheel

16 PARTS (CONTINUED)

16.2 HITCH ASSEMBLY

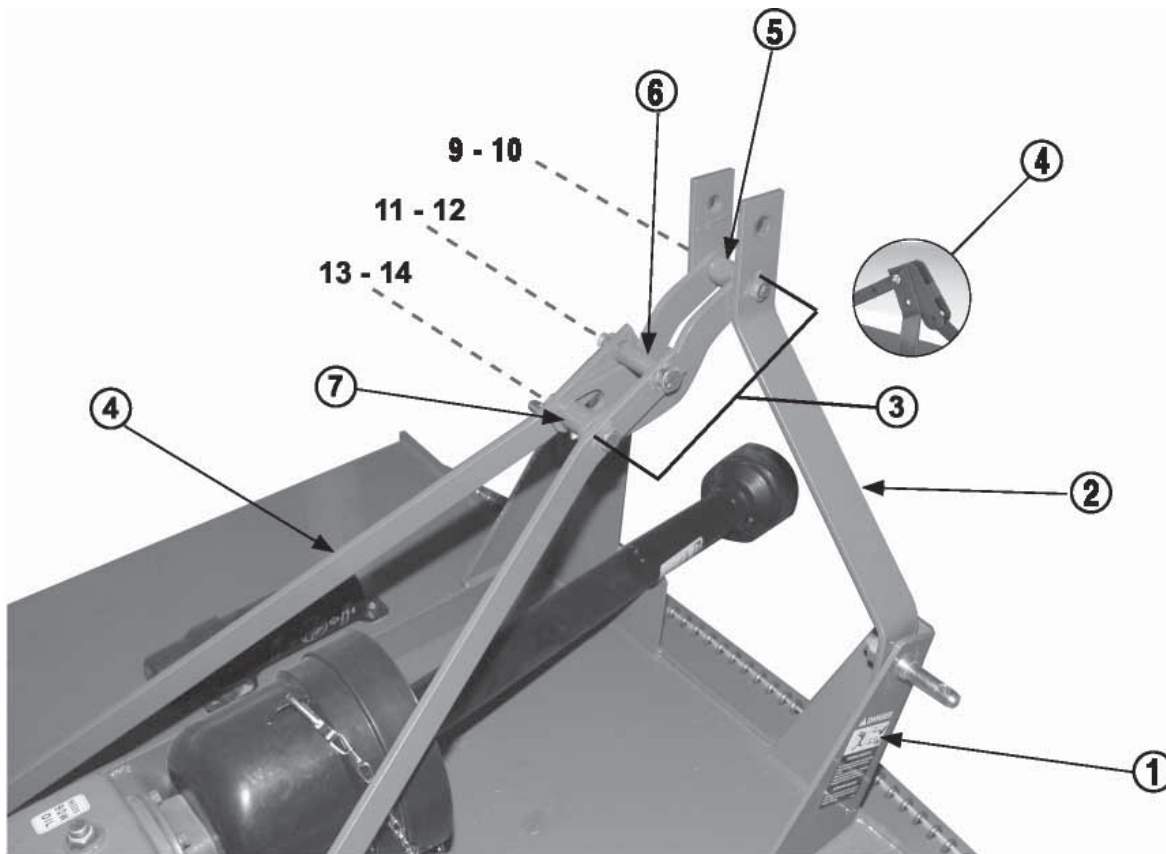

<u>REF. NO.</u>	<u>QTY.</u>	<u>PART NO.</u>	<u>DESCRIPTION</u>
1	1	N/A	Hitch Mount Lub.
2	2	300278	Top Link Mount
3	2	301277	Match Pivot Link Kit
4	2	301287	Non-Match Pivot Link Kit
5	2	300286	Top Link Mount Bushing
6	1	300281	Hitch Pivot Bushing
7	1	300280	Hitch Pivot Link
8	2	300283	Lift Strap RC200-48 and RC200-60
8	2	300284	Lift Strap RC200-72
9	1	100150	Top Link Bolt
9	1	100170	Top Link Lock Nut
10	1	100170	Hitch Pivot Bolt
11	1	100160	Hitch Pivot Lock Nut
12	1	100170	Hitch Pivot Link Bolt
13	1	100160	Hitch Pivot Link Lock Nut

16.3 GEARBOX AND BLADE PAN ASSEMBLY

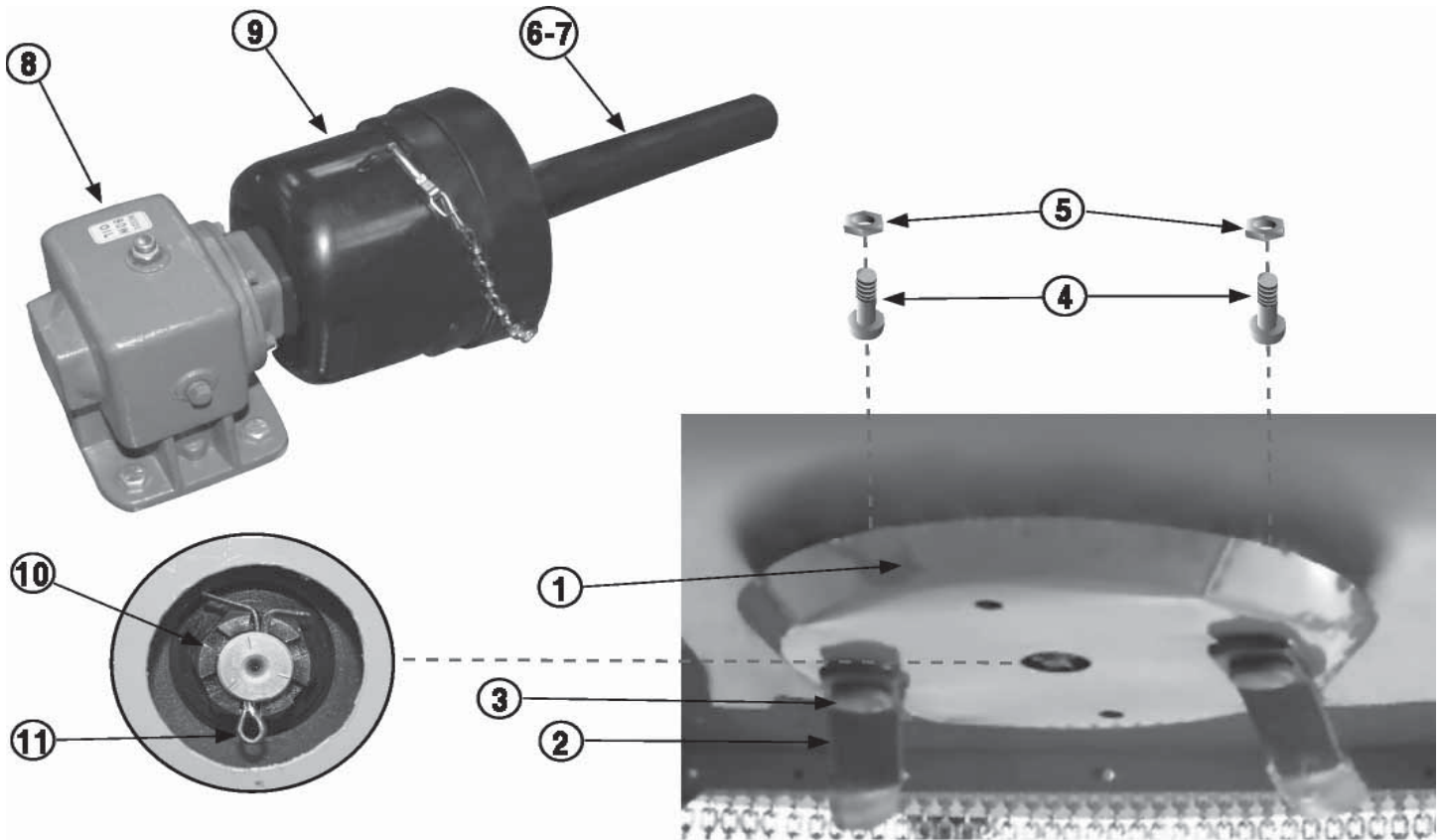

<u>REF. NO.</u>	<u>QTY.</u>	<u>PART NO.</u>	<u>DESCRIPTION</u>
1	1	301225	Blade Pan
2	1	300125	Blade Set (2 Blades) RC200-48
2	1	300126	Blade Set (2 Blades) RC200-60
2	1	301126	Blade Set (2 Blades) RC200-72
3	2	301227	Blade Bolt Assembly
4	1	381540	Blade Bolt
5	1	301228	Blade Bolt Nut
6	1	301230	PTO Shaft (Shear Pin) RC200-48
6	1	301231	PTO Shaft (Shear Pin) RC200-60 & RC200-72
7	2	301232	PTO Shaft (Slip Clutch) RC200-48
7	2	3011284	PTO Shaft (Slip Clutch) RC200-60 & RC200-72
8	1	300209	Gearbox 45 HP - RC200-48
8	1	300210	Gearbox 65 HP - RC200-60 & RC200-72
9	1	300211	Slip Clutch Shield Cone
10	1	300234	Blade Hub Nut (Gearbox Output Shaft)
11	1	100113	Cotter Pin (Gearbox)

16 PARTS (CONTINUED)

16.4 GEARBOX

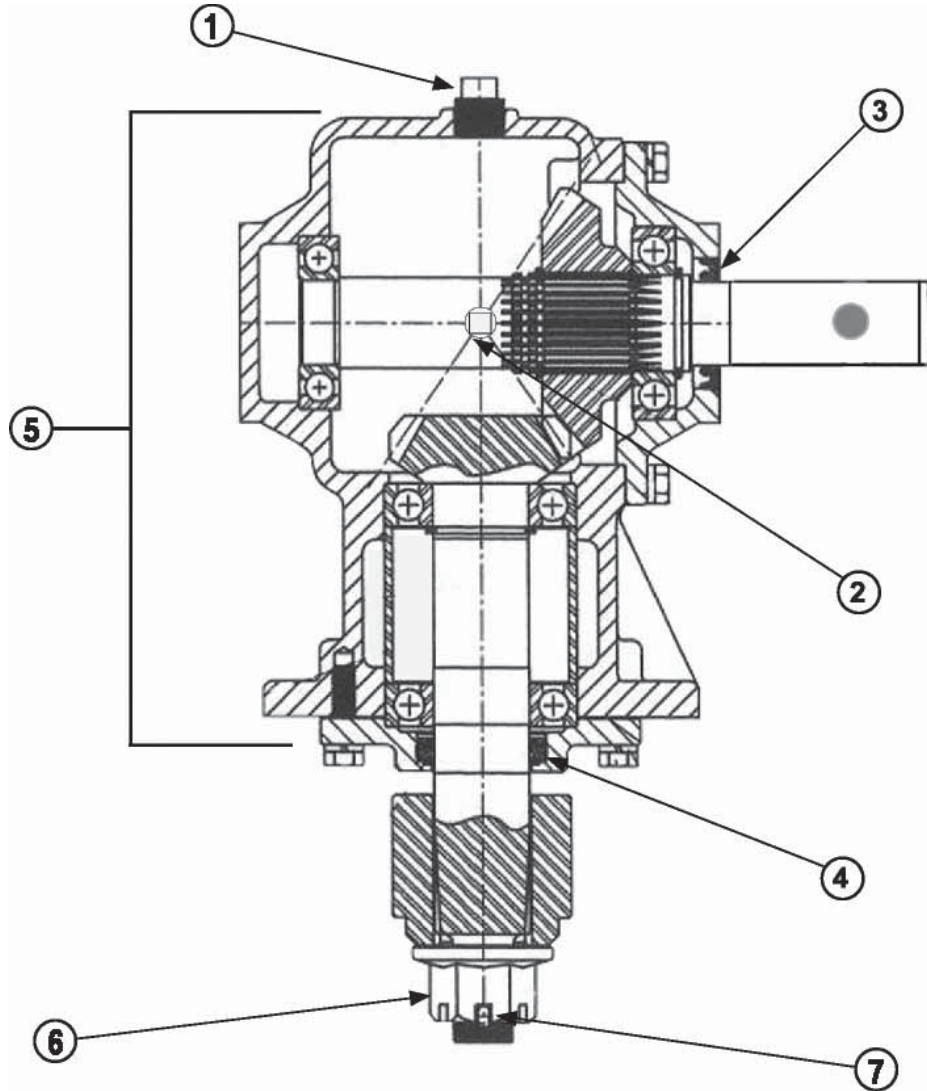

<u>REF. NO.</u>	<u>QTY.</u>	<u>PART NO.</u>	<u>DESCRIPTION</u>
1	1	300136	Breather Fill Plug
2	1	300202	Oil Level Plug ½"
3	1	300243	Seal, Input Shaft
4	1	300344	Seal, Output Shaft
5	1	300209	Gearbox 45 HP - RC200-48
5	1	300210	Gearbox 65 HP - RC200-60 & RC200-72
6	1	300234	Blade Hub Nut (Gearbox Output Shaft)
7	1	100113	Cotter Pin (Gearbox)

16 PARTS (CONTINUED)

16.5 PTO DRIVELINE SHEAR PIN ASSEMBLY

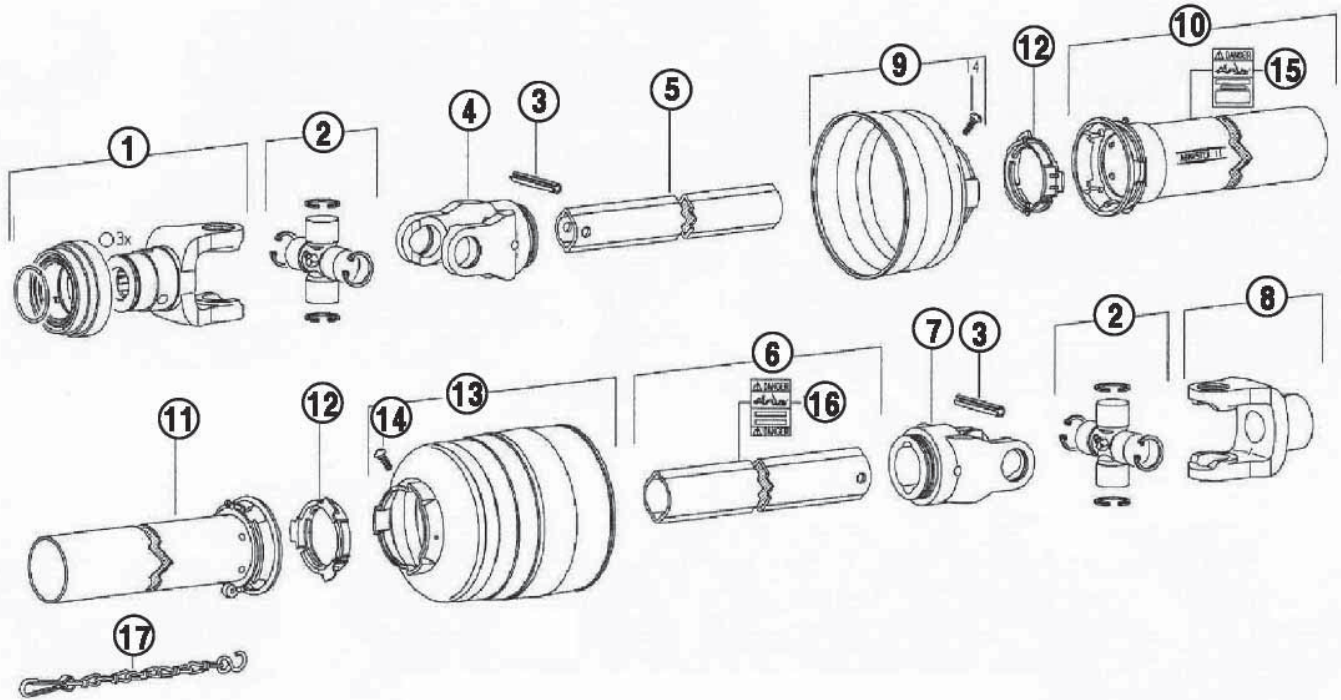

<u>REF. NO.</u>	<u>QTY.</u>	<u>PART NO.</u>	<u>DESCRIPTION</u>
1	1	300263	Collar Kit - In Item 1
2	2	300247	Cross and Bearing Kit
3	2	300248	Spring Pin 10 x 65
4	1	300249	Inboard Yoke OV
5	1	300250	Inner Profile OV for RC200-48
5	1	300266	Inner Profile OV for RC200-60 & RC200-72
6	1	300251	Outer Profile 1 for RC200-48
6	1	300267	Outer Profile 1 for RC200-60 & RC200-72
7	1	300252	Inboard Yoke 1
8	1	300264	Yoke 1 3/8" RB, O.531DT
9	1	300254	Shield Cone
10	1	300255	Outer Shield Tube Ovl. for RC200-48
10	1	300268	Outer Shield Tube Ovl. for RC200-60 & RC200-72
11	1	300256	Inner Shield Tube Rnd. for RC200-48
11	1	300269	Inner Shield Tube Rnd. for RC200-60 & RC200-72
12	2	300257	Bearing Ring SC15
13	1	300265	Shield Cone Extended (for Shear Pin)
14	2	300261	Screw-In (for Shield Cones)
15	1	300259	Decal (Out-In on Out Shield Tube)
16	1	300260	Decal (Outer Profile Inn-In)
17	1	300262	Safety Chain

16 PARTS (CONTINUED)

16.6 PTO DRIVELINE SLIP CLUTCH ASSEMBLY

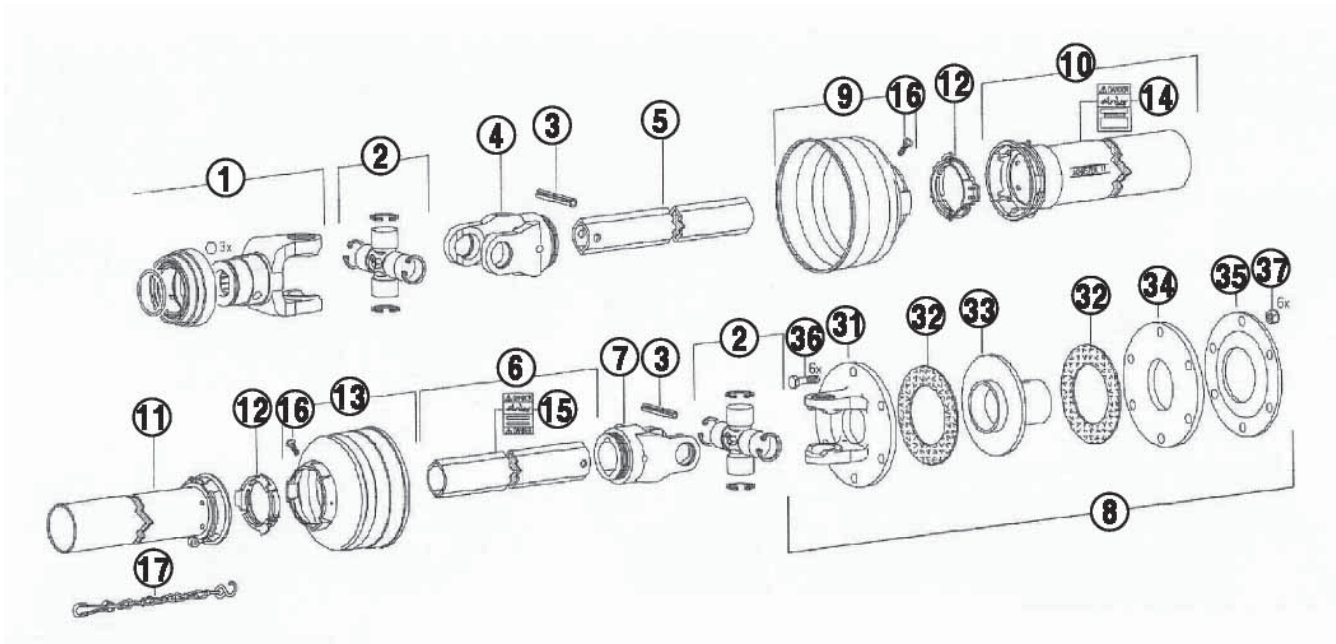

<u>REF. NO.</u>	<u>QTY.</u>	<u>PART NO.</u>	<u>DESCRIPTION</u>
1	1	300263	Collar Kit - In Item 1
2	2	300247	Cross and Bearing Kit
3	2	300248	Spring Pin 10 x 65
4	1	300249	Inboard Yoke OV
5	1	300250	Inner Profile OV for RC200-48
5	1	300266	Inner Profile OV for RC200-60 & RC200-72
6	1	300251	Outer Profile 1 for RC200-48
6	1	300267	Outer Profile 1 for RC200-60 & RC200-72
7	1	300252	Inboard Yoke 1
8	1	300253	Friction Slip Clutch
9	1	300254	Shield Cone
10	1	300255	Outer Shield Tube Ovl. for RC200-48
10	1	300268	Outer Shield Tube Ovl. for RC200-60 & RC200-72
11	1	300256	Inner Shield Tube Rnd. for RC200-48
11	1	300269	Inner Shield Tube Rnd. for RC200-60 & RC200-72
12	2	300257	Bearing Ring SC15
13	1	300258	Shield Cone (for Slip Clutch)
14	1	300259	Decal (Out-In on Outer Shield Tube)
15	1	300260	Decal (Outer Profile Inn-In)
16	2	300261	Screw-In (for Shield Cones)
17	1	300262	Safety Chain
31	1	300270	Flange Yoke
32	2	300271	Friction Disc
33	1	300272	Hub 1 3/8" RB
34	1	300273	Thrust Plate
35	1	300274	Belleville Spring
36	6	300275	Hex Bolt M10 x 50
37	6	300276	Hex Lock Nut M10

16.7 TAILWHEEL ASSEMBLY

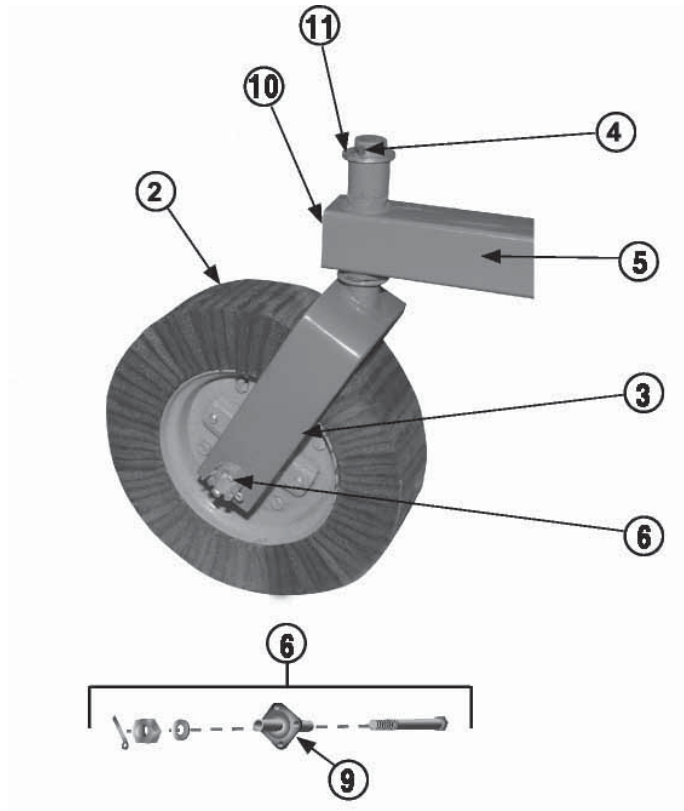

<u>REF. NO.</u>	<u>QTY.</u>	<u>PART NO.</u>	<u>DESCRIPTION</u>
2	1	300127	Tailwheel - Laminated Tire
3	1	300239	Tailwheel Fork with Roll Pin
4	1	300240	Roll Pin (Tailwheel Fork)
5	1	300290	Tailwheel Tube
6	1	300128	Axle Bolt Kit (1"x8" bolt w/flat washer, castle nut, cotter pin)
9	1	300130	Tailwheel Hub (w/lockwasher & locknut) Laminated Tire
10	1	100116	Grease Zerk
11	1	100115	1 1/4" Flat Washer

16 PARTS (CONTINUED)

16.8 RUBBER BELT AND FOOT GUARD ASSEMBLY

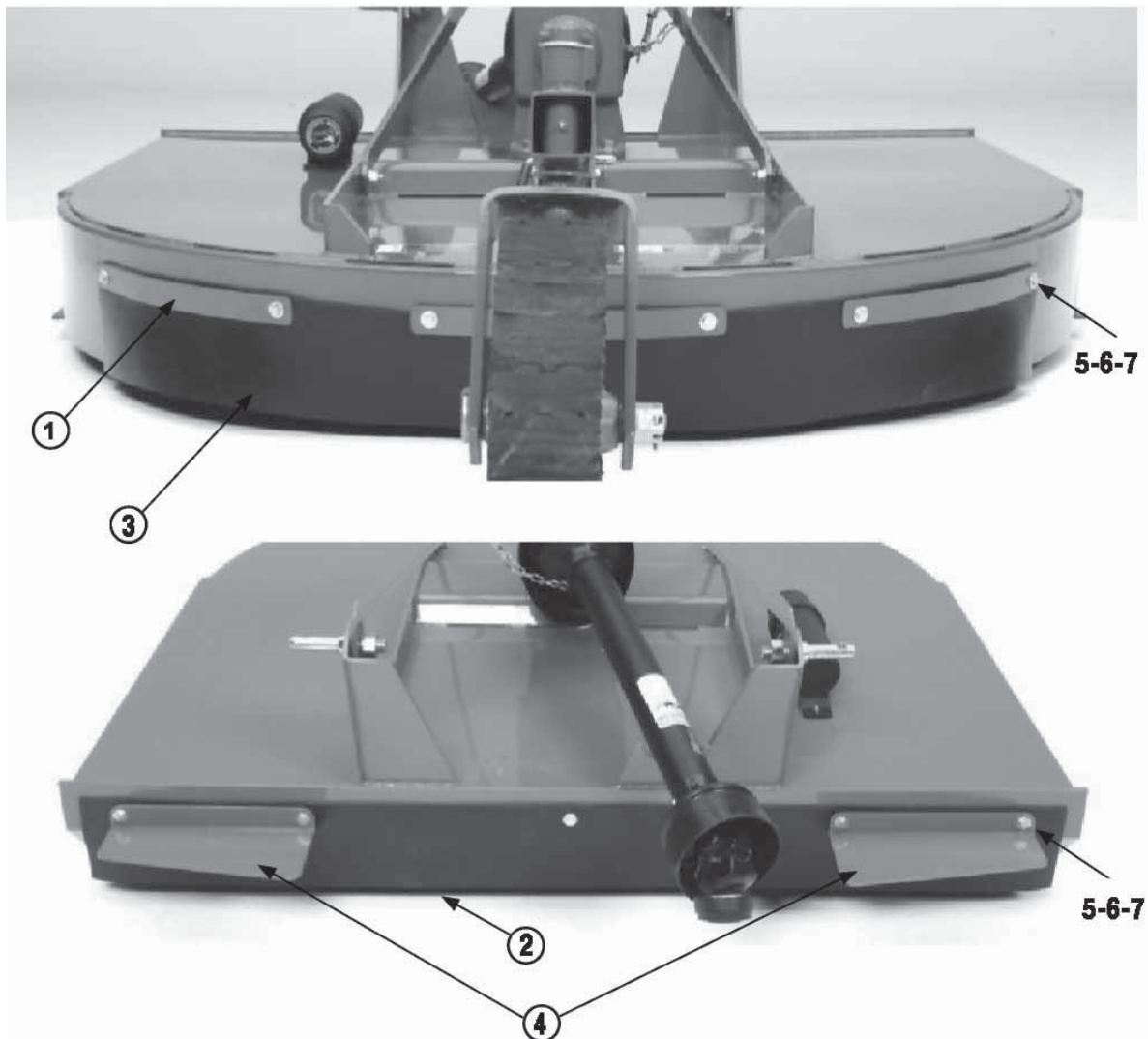

<u>REF. NO.</u>	<u>QTY.</u>	<u>PART NO.</u>	<u>DESCRIPTION</u>
1	1	300243	Rear Rubber Guard Frame Kit
2	1	300213	Front Rubber Guard RC200-48
2	1	300215	Front Rubber Guard RC200-60
2	1	300217	Front Rubber Guard RC200-72
3	1	300214	Rear Rubber Guard RC200-48
3	1	300216	Rear Rubber Guard RC200-60
3	1	300218	Rear Rubber Guard RC200-72
4	1	300212	Foot Guard
5	1	100203	$\frac{5}{16}$ x 1 $\frac{3}{4}$ " Bolt Grade 5
6	1	100142	$\frac{5}{16}$ " Flat Washer
7	1	100135	$\frac{5}{16}$ " Lock Nut

16.9 CHAIN GUARD ASSEMBLY

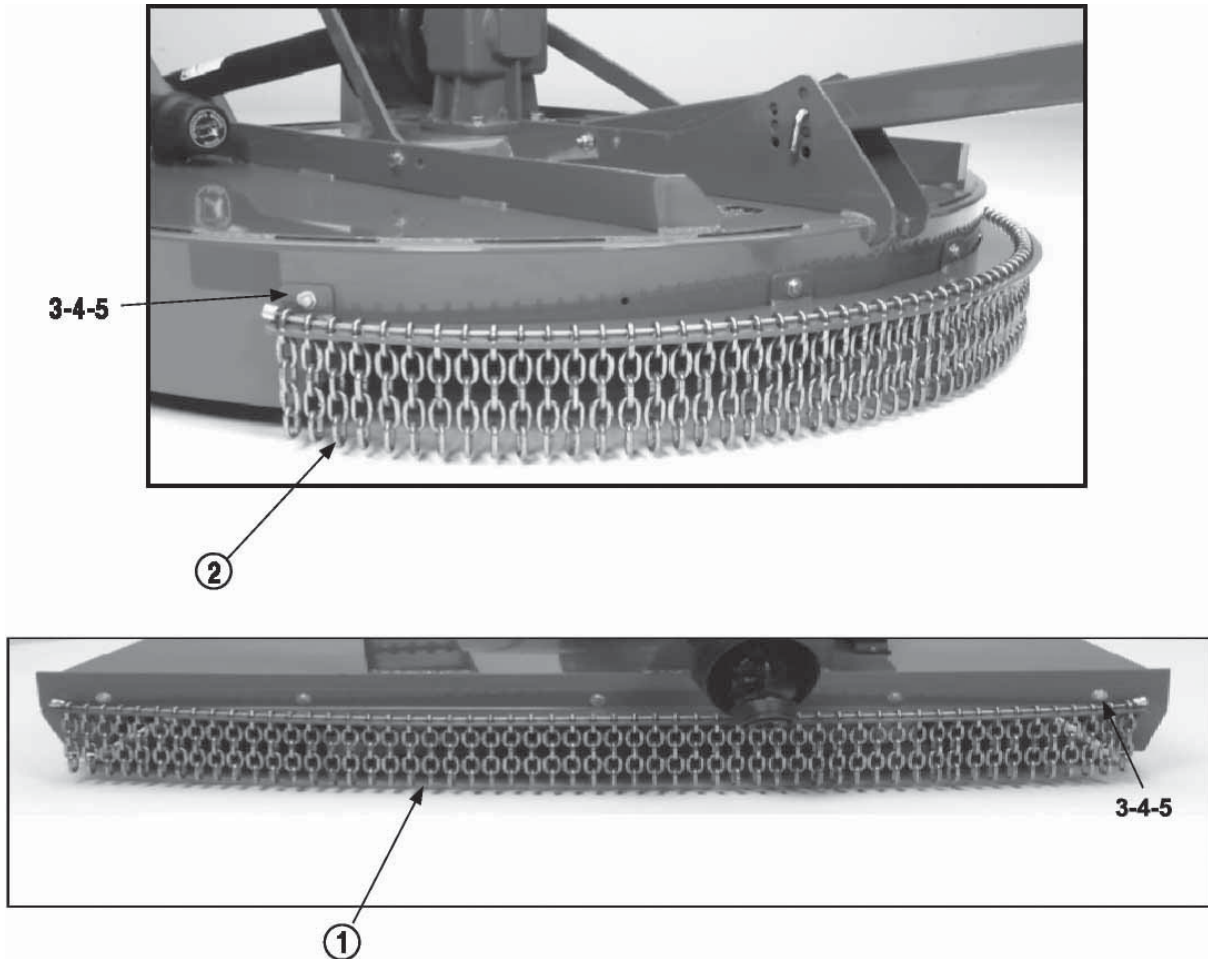

<u>REF. NO.</u>	<u>QTY.</u>	<u>PART NO.</u>	<u>DESCRIPTION</u>
1	1	300219	Front Chain Guard Kit RC200-48
1	1	300221	Front Chain Guard Kit RC200-60
1	1	300223	Front Chain Guard Kit RC200-72
2	1	300220	Rear Chain Guard Kit RC200-48
2	1	300222	Rear Chain Guard Kit RC200-60
2	1	300224	Rear Chain Guard Kit RC200-72
3	1	100202	5/16 x 1 1/2" Bolt Grade 5
6	1	100142	5/16" Flat Washer
7	1	100135	5/16" Lock Nut

17 LIMITED WARRANTY



GEARMORE, INC., warrants each new Gearmore product to be free from defects in material and workmanship for a period of twelve (12) months from date of purchase to the original purchaser. This warranty shall not apply to implements or parts that have been subject to misuse, negligence, accident, or that have been altered in any way.

Our obligation shall be limited to repairing or replacement of any part, provided that such part is returned within thirty (30) days from date of failure to Gearmore through the dealer from whom the purchase was made, transportation charges prepaid.

This warranty shall not be interpreted to render us liable for injury or damages of any kind or nature, direct, consequential or contingent, to person or property. This warranty does not extend to loss of crops, loss because of delay in harvesting or any other expenses, for any other reasons.

Gearmore in no way warrants engines, tires, or other trade accessories, since these items are warranted separately by these respective manufacturers.

Gearmore reserves the right to make improvements in design or changes in specification at any time, without incurring any obligations to owners or units previously sold.

GEARMORE, INC.
13477 Benson Ave.
Chino, CA 91710

Always refer to and heed machine operating warning decals on machine.

The serial number of this product is stored in our computer database, thus submitting a warranty registration card is not required.