



ROTARY TILLER

**Operation, Service
& Parts Manual For
“P-P/C” Series**

November 1996 (Rev. 4-05)

TABLE OF CONTENTS

Preparation	1
Assembly Instructions	2
Connection to Tractor	3
General Maintenance	4
Setting Tiller Rotorshaft R.P.M.	5
Safety Information	6
Safety Decals	7-9
Troubleshooting	10
Replacing Clutch Linings	11
Tiller Assembly	12-15
Gearbox Assembly Single Speed	16-17
Gearbox Assembly 4 Speed	18-19
Driveline Assembly	20
Limited Warranty	21

Date of Purchase: _____

Model Number: _____

Serial Number _____

PREPARATION

WARNING

To prevent possible personal injury or death during assembly, installation, operation, adjustment, or removal of implement, **DO NOT** wear loose clothing, always wear gloves and safety glasses or face shield. **Keep other persons a minimum of twenty-five (25) feet away from any unit under power.**



READ THIS BEFORE OPERATING TILLER

TRAINING

Know your controls. Read this operator's manual and the manual provided with your tractor. Learn how to stop the tractor engine and tiller quickly, in case of an emergency. **DO NOT** allow children to operate machine, or adults to operate it without proper instructions.

PREPARATION

- Clear area of debris.
- Never permit any person other than the operator to ride on board the tractor at any time.
- **DO NOT** allow riders on tiller at any time.
- Operate only in daylight or good artificial light.
- Ensure all safety shielding is properly installed.
- *Always* wear relatively tight and belted clothing when operating tiller. Loose clothing should not be worn, as it could get caught in the moving parts or controls.

ASSEMBLY INSTRUCTIONS

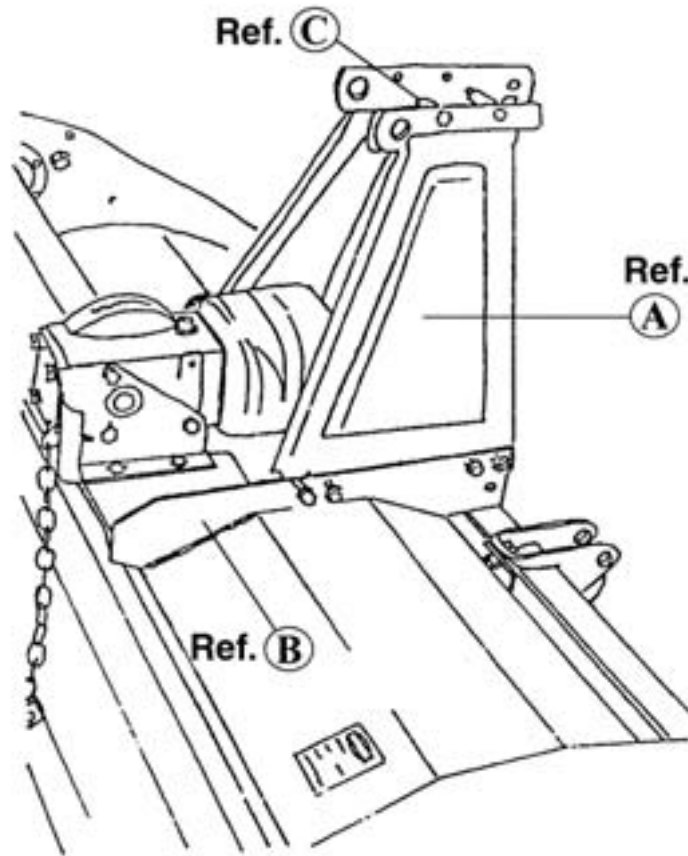

1. With Tiller on bottom pallet, install a-frame mast (Ref. A). *Note:* The mast mounts on the inside of the rails (Ref. B).
2. Install spacer (Ref. C) between the two a-frame masts using supplied bolt and nut.
3. Tighten all bolts and nuts.
4. Install PTO driveline to tiller gearbox. *Note:* The slip clutch assembly goes to the tiller gearbox.
5. Check oil in gearbox and chain case (140 SAE Lube).

CONNECTION TO TRACTOR

Your Gearmore Rotary Tiller can be attached to tractors having a Category “I” or Category “II”, 3-point hitch.

1. Attach the lower link arms of the tractor to the lower attaching brackets of the tiller by inserting the pins. **NOTE:** Hitch brackets can be adjusted for offset.
2. Attach the top link of the 3-point hitch to the tiller. Next, tighten the lower link arm check chains to prevent any horizontal movement of the tiller, which could cause damage during operation. Adjust the unit so the drive shaft is parallel to the ground in the working position. Adjust the tractor lift linkage or the hydraulic lever lifting stops to prevent the tiller being lifted more than 6” from the ground. This will avoid any damage to the universal joints.
3. Attach the drive shaft, first to the tiller input shaft and then to the PTO of the tractor. Make sure the yokes are locked on to the tractor and tiller shaft.

SLIP CLUTCH DRIVE SHAFT:

This tiller has a drive shaft with a slip clutch, which has been calibrated for a certain overload. To adjust the clutch, tighten or loosen bolts equally. Don't over-tighten or clutch will lock and not slip under stress, which could cause damage during operation. The clutch assembly should get warm under normal operation. If the clutch gets extremely hot, this is a sign of slippage. If the machine sits for an extended period of time with no usage, the bolts should be loosened and the PTO engaged. This will allow the clutch discs to become free again. After a few seconds, shut-off the tractor and retighten bolts equally. Recheck clutch assembly for temperature after using in tilling application. If it is too hot, the bolts need tightening. If it is too cool, loosen bolts.

SET SIDE SKIDS FOR WORKING DEPTH:

To regulate working depth, loosen the nuts of the skids and adjust them to the desired position. Set skids equally on both sides.

TRANSMISSION CHAIN TENSION:

Your Gearmore Rotary Tiller has an automatic chain tensioner, so no adjustment is necessary.

TINES:

When the complete set of tines has to be replaced, it is advisable to replace one at a time to insure that the new tines are mounted in the same position as the old ones. It is important to fit the bolts with the heads to the side of the tine and the nuts and washers to the side of the flange. It is also recommended to replace all washers with new ones at the time of tine replacement.

GENERAL MAINTENANCE

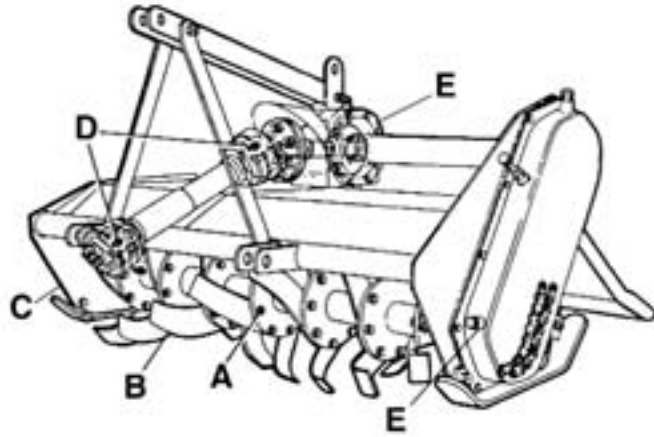

Carefully follow all instructions as stated in this operator's manual, this includes safety, assembly, operation, lubrication, and maintenance of the tiller.

1. Check lubrication - See Lubrication Section.
2. Check bolts and nuts for tightness (Ref. A).
3. Check tiller daily for loose, worn or broken tines (Ref. B).
4. Replace, **immediately**, any damaged or worn parts.

LUBRICATION

GEARBOX & CHAIN CASE:

Fill gearbox and chain case to level plug (Ref. E) with gear oil. Use SAE #140 multi-gear lubricant or equivalent. Gear oil should be checked weekly and changed *every 400 hours* of use.

ROTOR SHAFT:

Lubricate rotor spindle (Ref. C) *daily*. **NOTE:** Grease zerk located on the side of the tiller.

DRIVE SHAFT:

Grease both cross and shield bearings (Ref. D). After that grease *every 8 hours* of use. It is also necessary, from time to time, to untelescope the drive shaft to clean and re-grease tubing.

NOTE: Driveshafts with a slip clutch do not have a grease zerk on the clutch assembly.

WARNING - DO NOT OPERATE TILLER UNLESS ALL SHIELDS ARE IN PLACE

SETTING TILLER ROTOR SHAFT R.P.M.

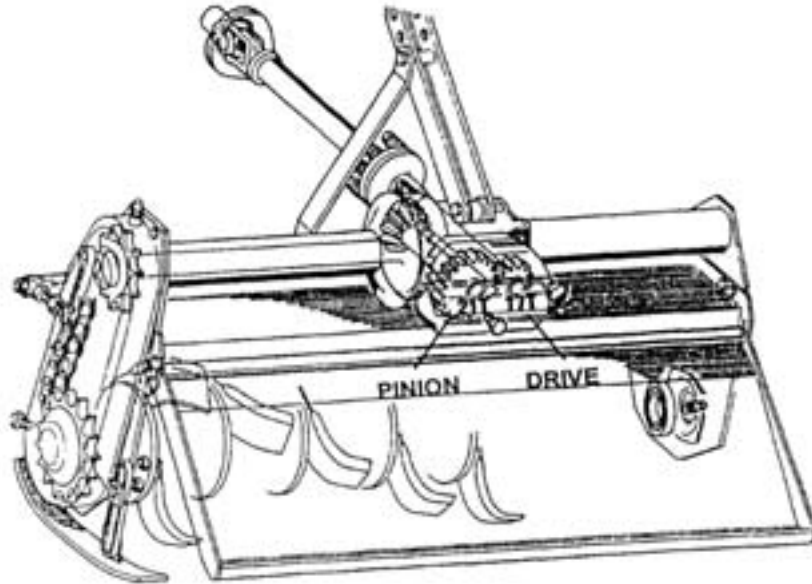

GEAR SETTING	PINION GEAR	DRIVE GEAR	540 R.P.M. SPEED
1	21T	17T	190 R.P.M.
2	20T	18T	210 R.P.M.
3	18T	20T	260 R.P.M.
4	17T	21T	290 R.P.M.

1. Make sure the tiller is sitting on the ground, the tractor engine off, and parking brake set. The tiller should be level or tilted slightly forward to minimize oil dripping out the back.
2. Remove cover from the back side of gearbox.
3. Verify the rotor R.P.M. you want to achieve and set the gear ratio with the corresponding gears on the chart.

EXAMPLE: You want to achieve 190 R.P.M., then put the 21 tooth gear on the *pinion* side and 17 tooth gear on the *drive* side (see above picture). Run tractor P.T.O. at the 540 R.P.M. setting.

4. Install the spare gears to inside of cover and replace cover on gearbox.
5. Torque bolts on cover to 2 ft/lbs (24 inch pounds) and check the oil level of gearbox.

SAFETY INFORMATION

OPERATIONAL SAFETY:

- Guards and safety shields are for your protection. **DO NOT** operate equipment unless they are in place.
- Always operate tractor PTO (power take-off) at recommended RPM (revolutions per minute).
- Disengage tractor PTO and shift into neutral before attempting to start engine.
- Read and observe all safety decals on the tractor and tiller. (*See pages 7 - 9*)
- NEVER** allow anyone within 25' of machine while it is in operation.
- Do not stop or start suddenly when going uphill or downhill. Avoid operation on steep slopes.
- Be alert for holes in terrain and other hidden hazards. Always drive slowly over rough ground.
- Reduce speed on slopes and in sharp turns to prevent tipping or loss of control. Be careful when changing direction on slopes.
- Stop tiller and tractor immediately upon striking an obstruction. Turn off engine, inspect tiller, and repair any damage before resuming operation.
- Disengage power to tiller and stop engine before dismounting from tractor, before making any repairs or adjustments, transporting, or unclogging tiller.
- Take all possible precautions when leaving tractor unattended: Disengage PTO, lower tiller, shift into neutral, set parking brake, stop engine, and remove key from ignition.
- Front tractor weights or front tire ballast should be used to enhance front end stability on small tractors.
- Check to make sure PTO is properly connected and that the driveline is correct to prevent bottoming out or pulling apart during the full lift range of the hitch.
- Never work under tiller without safety blocks.
- This implement is designed for a one-man operation. It is the responsibility of the tractor operator to see that no one is in the proximity of the implement when it is started. **DO NOT** operate the implement with another person within 25' of the implement or PTO drive.

TILLER SAFETY DECALS

1. Keep all safety decals and signs clean and legible at all times.
2. Replace safety decals and signs that are missing or have become illegible. (Contact Gearmore at 909 548-4848 for *free* replacement safety decals.)

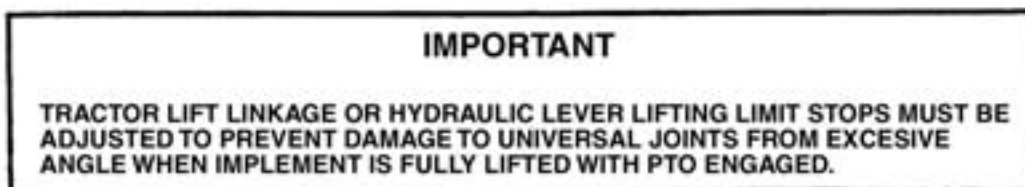
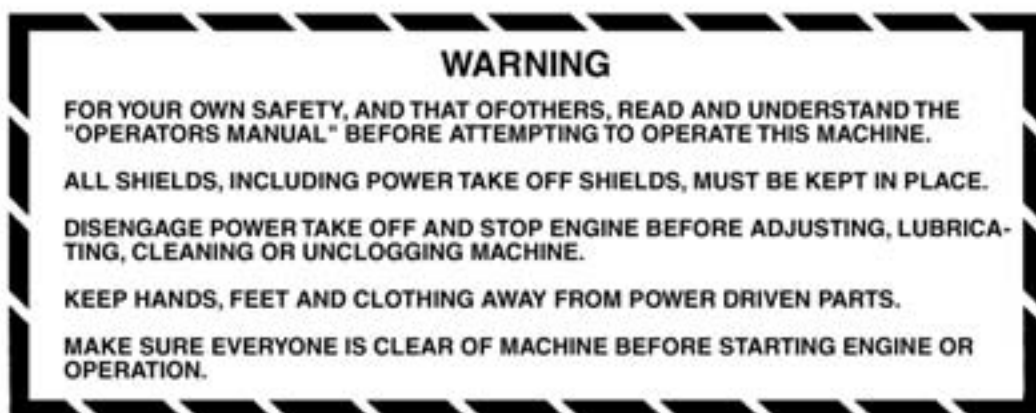

TILLER SAFETY DECALS



DANGER: Hands and feet could be severely injured. Keep away from rotating parts.



DANGER: Do not stay behind the machine as it could roll over you.



DANGER: Never get near to the PTO shaft while it is in operation. ACCIDENTAL CONTACT COULD CAUSE DEATH.

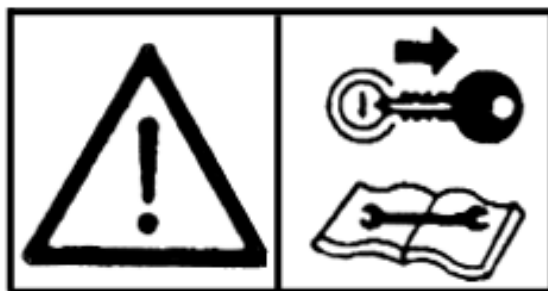

Stop both the machine and the tractor before performing any service.

TILLER SAFETY DECALS

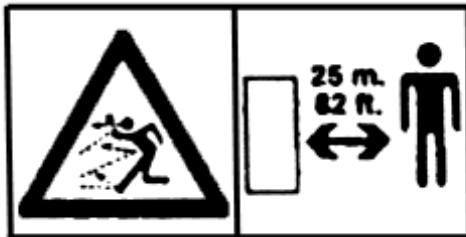

DANGER: The machine could throw heavy or sharp objects. Keep at a safe distance from the machine.

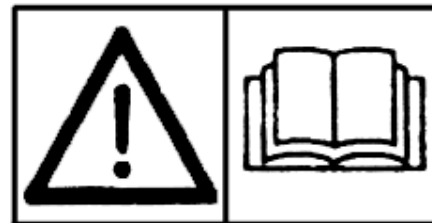

Please carefully read and understand the operating instructions before using the machine.

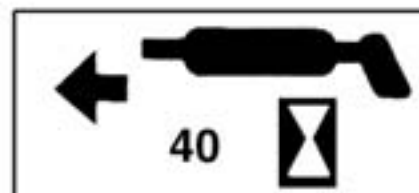

TROUBLESHOOTING CHART

PROBLEM	CAUSE	SOLUTION
Excessive vibration	Drive shaft damaged	Replace worn drive shaft
	Tines broken off	Replace damaged tines
	Bent rotor shaft	Replace rotor shaft
Rotor shaft does not turn	PTO Clutch slipping	Check slip clutch adjustment
		Replace clutch discs
Tilling deeper on one side	Tractor lower lift arm out of adjustment	Adjust lift arm
	Tiller depth skid not properly adjusted	Adjust skids to level depth
Tiller bouncing	Trying to go too deep on first pass	Raise tiller so tilling 3" deep
	Tractor in too high a gear	Tiller runs smoother in first or second gear
Leaving tire tracks	Tires set out too wide	Set in tractor tires
	Tractor too large	Offset tiller to cover right tire tracks
PTO will not untelescope	Improper lubrication	Separate and grease both halves
	PTO twisted	Replace twisted parts
	Shields damaged	Replace shields

REPLACING CLUTCH LININGS

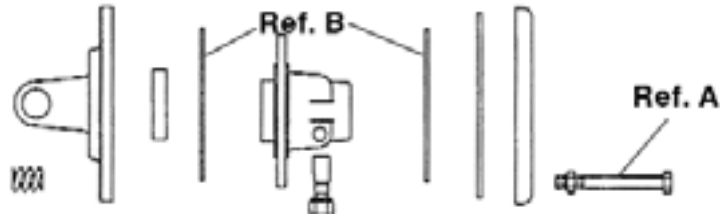

1. Mount clutch assembly in vise.
2. Remove all bolts and nuts (Ref. A).
3. Disassemble all components.
4. Check the condition of all parts, friction plates especially.
5. Replace clutch linings (Ref. B).
6. Reassemble the components, install spring with their corresponding bolts and nuts.
7. Tighten nuts following an alternating cross pattern until reaching a height of 27 mm (1.063").
8. Check that the height is the same for all springs.
9. Reinstall driveline, making sure all shields are in place.

PROTECTION GUARDS

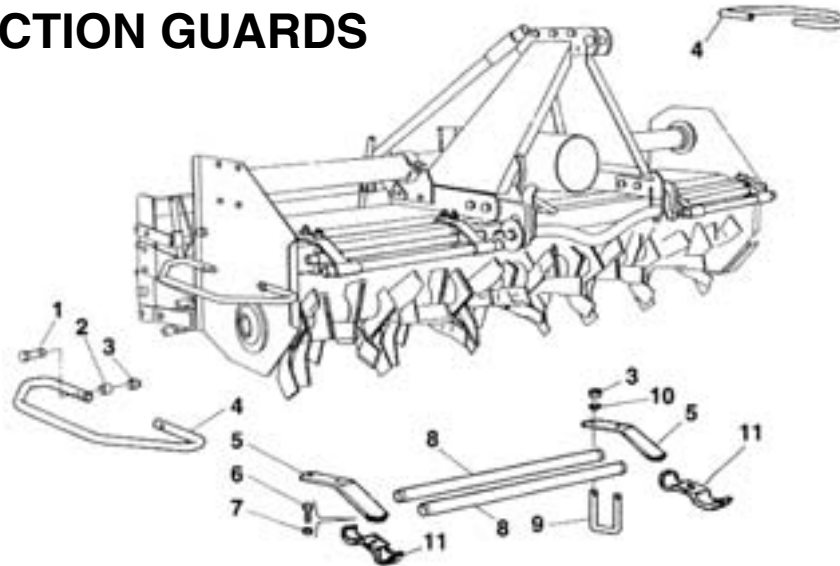

<u>REF#</u>	<u>QTY.</u>	<u>PART NO.</u>	<u>DESCRIPTION</u>
1	4	80.Z.01.069	Bolt M10 x 55
2	4	72.80.0034	Spacer
3	8	80.Z.11.012	Locknut M10
4	2	76.90.0001	Side Protection Bar
5	4	78.48.0120	Front Support Bracket
6	4	80.Z.03.137	Bolt M10 x 30
7	4	80.Z.11.012	Locknut M10
8	4	78.94.0011	Front Protection Bar
9	4	72.21.0003	Channel Bolt M10 x 100 x 71
10	8	80.Z.30.010	Flat Washer
11	4	78.44.0016	U-Clamp
12	1	65.15.0022	Complete Guard

"P" TILLER ASSEMBLY

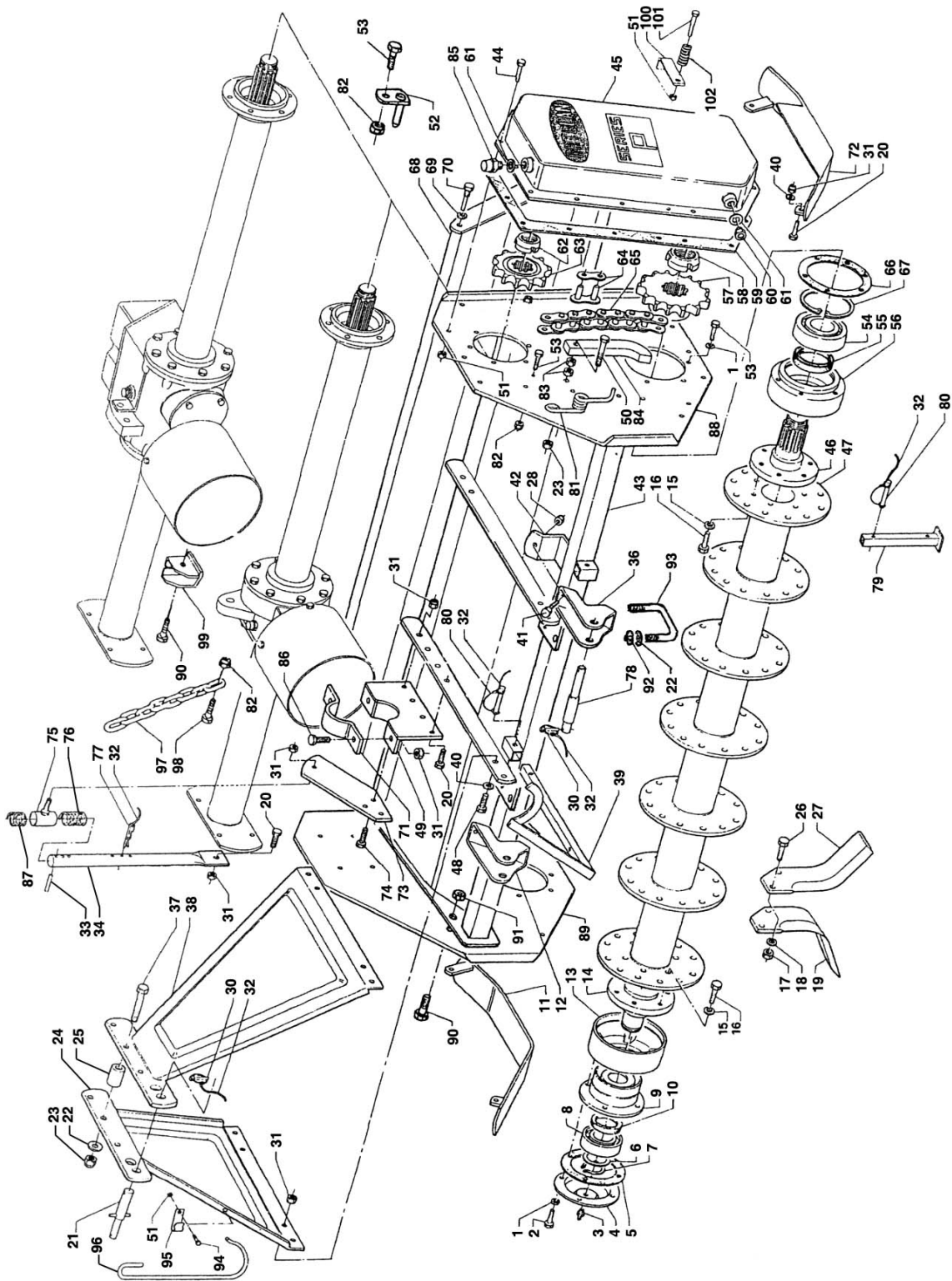

TILLER ASSEMBLY

<u>REF#</u>	<u>QTY.</u>	<u>PART NO.</u>	<u>DESCRIPTION</u>
1	10	80.S.35.110	Washer M10
2	4	80.R.03.138	Bolt M10 x 35
3	1	80.Z.61.010	Grease Zerk M8 x 1.25
4	1	72.44.0017	Cover, Rotor
5	1	74.41.0030	Gasket
6	1	80.S.45.297	Spacer 40 x 51 x 1
7	1	47140	Circlip E40
8	1	6308	Bearing 40 - 90 - 23
9	1	78.48.0010	Support, Rotor
10	1	50X65X8	Oil Seal 50 x 65 x 8
11	1	78.16.0010	Skid, R.H.
12	1	71.46.0014	Bracket, 2 Pt. Hitch R.H.
13	1	72.48.0005	Cover
14	1	75.92.0005	Hub, Rotor
15	12	80.S.35.112	Washer M12
16	12	80.Z.00.021	Bolt M12 x 30 x 1.25
17	See Chart Pg. 15	80.Z.08.111	Nut M14 x 1.5
18	See Chart Pg. 15	80.S.35.114	Lockwasher M14
19	See Chart Pg. 15	79.66.0011	Tine R.H.
20	6	80.Z.03.160	Bolt M12 x 35
21	1	76.65.0015	Pin, Top Link
22	10	80.Z.30.014	Washer M14
23	3	80.Z.11.017	Lock Nut M14
24	1	73.68.0008	A-frame Mast R.H.
25	2	72.80.0015	Spacer
26	See Chart Pg. 15	80.Z.00.033	Bolt M14 x 40 x 1.5
27	See Chart Pg. 15	79.66.0012	Tine L.H.
28	4	80.Z.11.018	Lock Nut M16 x 1.5
30	3	80.S.77.015	Click Pin D.10
31	16	80.Z.11.015	Lock Nut M12
32	4	80.P.05.001	Tie Rubber
33	1	80.Z.62.252	Roll Pin M6 x 40
34	1	71.42.0014	Rod, Tailboard Support (Before s/n 03922)
36	1	71.46.0015	Bracket, 2 Pt. Hitch L.H.
37	2	80.Z.01.115	Bolt M14 x 90
38	1	73.68.0009	A-frame Mast L.H.
39	1	78.48.0114	Support, P.T.O.
40	14	80.Z.30.012	Washer D.12
41	4	80.Z.00.046	Bolt M16 x 50 x1.5
42	2	78.44.0003	Clamp
43	1	78.60.0074	Frame P120 (Before s/n 0779)
43	1	78.60.0075	Frame P140 (Before s/n 0779)
43	1	78.60.0076	Frame P165 (Before s/n 0779)
43	1	78.60.0077	Frame P185 (Before s/n 0779)
43	1	78.60.0078	Frame P205 (Before s/n 0779)

TILLER ASSEMBLY

<u>REF#</u>	<u>QTY.</u>	<u>PART NO.</u>	<u>DESCRIPTION</u>
43	1	78.60.0024	Frame P120 (After s/n 0780)
43	1	78.60.0025	Frame P140 (After s/n 0780)
43	1	78.60.0026	Frame P165 (After s/n 0780)
43	1	78.60.0027	Frame P185 (After s/n 0780)
43	1	78.60.0028	Frame P205 (After s/n 0780)
44	16	80.R.03.112	Bolt M8 x 25
45	1	72.14.0009	Cover, Chain Case
46	1	75.92.0006	Hub, Rotor
47	1	77.85.0011	Rotor Shaft P120
47	1	77.85.0012	Rotor Shaft P140
47	1	77.85.0013	Rotor Shaft P165
47	1	77.85.0014	Rotor Shaft P185
47	1	77.85.0020	Rotor Shaft P205
48	6	80.Z.03.159	Bolt M12 x 30
49	1	78.48.0102	Support
50	1	80.R.03.190	Bolt M14 x 70
51	18	80.Z.11.009	Lock Nut M8
52	2	76.65.0024	Pin Tailboard Mount (After s/n 0780)
53	9	80.Z.03.136	Bolt M10 x 25
54	1	6310	Bearing 50 - 110 - 27
55	1	65X85X10	Oil Seal 65 - 85 - 10
56	1	78.48.0007	Support, Rotor
57	1	76.75.0023	Sprocket, Lower Z-13 P
57	1	76.75.0024	Sprocket, Lower Z-14 P/C
58	1	80.Z.55.014	Lock Nut M45 x 1.5
59	1	74.41.0045	Gasket
60	1	80.F.90.553	Drain Plug 1/2"
61	2	80.S.38.232	Gasket 21.5 - 27 - 1.5
62	1	80.Z.56.013	Lock Nut M40 x 1.5
63	1	76.75.0021	Sprocket, Upper Z-10 P/C
63	1	76.75.0022	Sprocket, Upper Z-11 P
64	1	80.A.31.930	Master Link ASA-120H
65	1	80.A.31.310	Chain ASA-120H 38 Links (Includes Ref. #64)
66	1	74.41.0013	Gasket
67	1	472110	Circlip I110
68	1	72.30.0021	Tailboard P120 (Before s/n 0779)
68	1	72.30.0022	Tailboard P140 (Before s/n 0779)
68	1	72.30.0023	Tailboard P165 (Before s/n 0779)
68	1	72.30.0024	Tailboard P185 (Before s/n 0779)
68	1	72.30.0025	Tailboard P205 (Before s/n 0779)
68	1	72.30.0110	Tailboard P120 (After s/n 0780)
68	1	72.30.0111	Tailboard P140 (After s/n 0780)
68	1	72.30.0112	Tailboard P165 (After s/n 0780)
68	1	72.30.0113	Tailboard P185 (After s/n 0780)

TILLER ASSEMBLY

REF#	QTY.	PART NO.	DESCRIPTION
68	1	72.30.0114	Tailboard P205 (After s/n 0780)
69	1	80.S.35.118	Washer M18 (Before s/n 0779)
70	1	76.65.0009	Pin (Before s/n 0779)
71	1	72.21.0001	Clamp
72	1	78.16.0011	Skid, L.H.
73	1	78.44.0060	Support Bracket
74	2	80.R.03.161	Bolt M12 x 40
75	1	78.48.0113	Support Tube (Before s/n 03922)
76	1	75.85.0006	Spring (Before s/n 03922)
77	1	80.Z.75.506	Hair Pin D.5 (Before s/n 03922)
78	2	76.65.0003	Lift Pin
79	1	76.74.0002	Jackstand
80	1	80.S.77.021	Pin D.10 x 70
81	1	75.85.0005	Spring
82	1	80.Z.11.012	Lock Nut M10
83	3	80.S.02.011	Nut M14
84	1	78.63.0003	Tension Arm
85	1	80.F.90.116	Breather Plug 1/2"
86	2	80.R.01.087	Bolt M12 x 45
87	1	75.85.0007	Spring (Before s/n 03922)
88	1	73.68.0054	Side Plate L.H. (After s/n 0780)
89	1	73.68.0055	Side Plate R.H. (After s/n 0780)
90	11	80.R.03.159	Bolt M12 x 30 (After s/n 0780)
91	10	80.Z.11.015	Lock Nut M12 (After s/n 0780)
92	8	80.Z.11.017	Lock Nut M14 (After s/n 01535)
93	4	72.21.0014	Square Bolt M14 x 70 (After s/n 01535)
94	1	80.Z.03.108	Bolt M8 x 16
95	1	73.58.0002	Lock Clip PTO Shaft Holder
96	1	74.14.0002	PTO Shaft Holder
97	1	72.20.0005	Chain, Tailboard 17 Links
98	1	80.Z.03.138	Bolt M10 x 35
99	1	78.48.0108	Chain Support R.H.
99	1	78.48.0123	Chain Support L.H. (P230)
100	1	73.58.0013	Tailboard Lock
101	1	80.Z.01.047	Bolt M8 x 45
102	1	75.85.0022	Spring Tailboard Lock
		79.66.0011	C Tine R.H.
		79.66.0012	C Tine L.H.
		80.Z.00.033	Bolt
		80.Z.08.111	Nut

TILLER TINE CHART			
MODEL NO.	NUMBER OF TINES		NUMBER OF BOLTS & NUTS
	R.H.	L.H.	
P120	15	15	60
P140	18	18	72
P165	21	21	84
P185	24	24	96
P205	27	27	108

GEARBOX ASSEMBLY SINGLE SPEED "P"

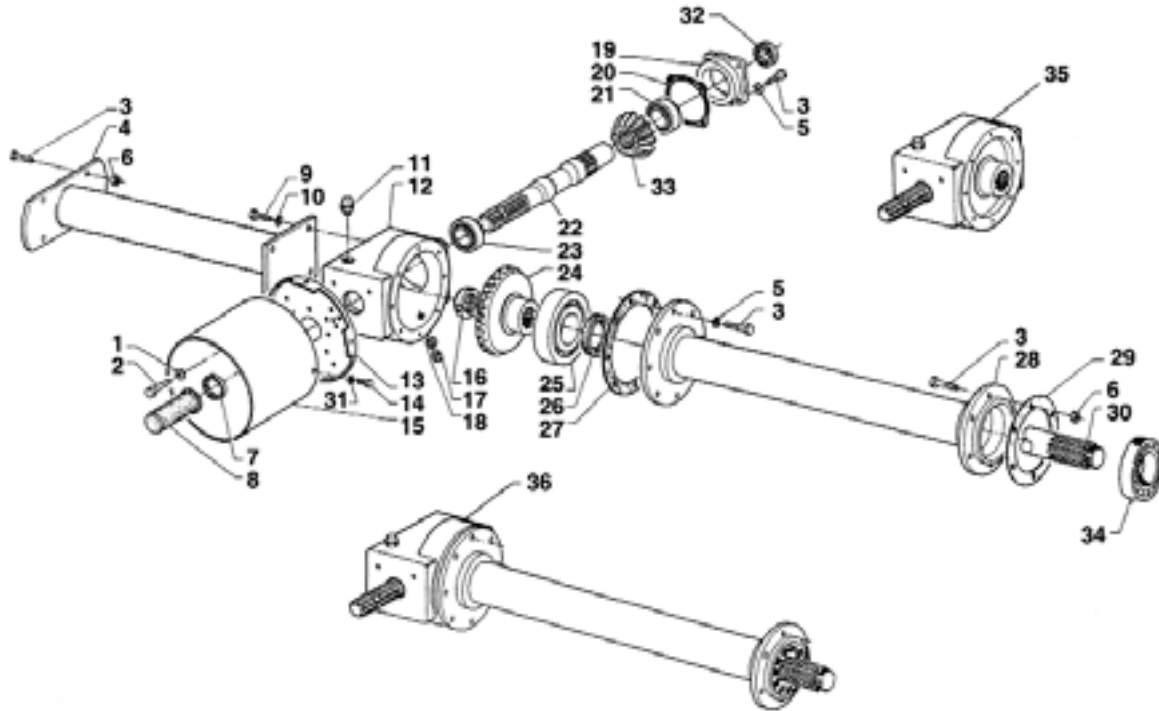

<u>REF#</u>	<u>QTY.</u>	<u>PART NO.</u>	<u>DESCRIPTION</u>
1	2	80.Z.31.108	Washer D.8 x 30
2	2	80.Z.03.108	Bolt M8 x 15
3	22	80.Z.03.137	Bolt M10 x 30
4	1	76.87.0086	Spacer P120
4	1	76.87.0041	Spacer P140
4	1	76.87.0042	Spacer P165
4	1	76.87.0043	Spacer P185
4	1	76.87.0045	Spacer P205
5	12	80.S.35.110	Lock Washer M10
6	10	80.Z.11.012	Lock Nut M10
7	1	40X52X7	Oil Seal 40 x 52 x 7
8	1	80.P.09.001	Cover
9	4	80.R.03.158	Bolt M12 x 25
10	4	80.S.35.112	Lock Washer D.12
11	1	80.F.90.116	Breather Plug 1/2"
12	1	78.04.0007	Housing
13	1	78.48.0111	Support Plate
14	3	80.Z.03.110	Bolt M8 x 20
15	1	72.48.0004	Cone, PTO
16	1	80.Z.55.014	Lock Nut M45 x 1.5
17	2	80.F.90.553	Drain Plug

GEARBOX ASSEMBLY SINGLE SPEED "P"

<u>REF#</u>	<u>QTY.</u>	<u>PART NO.</u>	<u>DESCRIPTION</u>
18	3	80.S.38.232	Gasket 21.5 - 27 - 1.5
19	1	72.44.0016	Cover
19	1	72.44.0019	Cover, Thru Shaft
20	1	74.41.0034	Gasket 0.1
20	1	74.41.0035	Gasket 0.3
21	1	31310	Bearing 50 - 110 - 29.25
22	1	71.12.0035	Thru Shaft, Input
22	1	71.12.0037	Input Shaft
23	1	30208	Bearing 40 - 80 - 19.75
24	1	72.46.0010	Bevel Gear Z29
25	1	32212	Bearing 60 - 110 - 29.75
26	1	60X80X10	Oil Seal 60 x 80 x 10
27	1	74.41.0038	Gasket 0.3
27	1	74.41.0039	Gasket 0.5
28	1	76.87.0047	Extension Tube P120 (Before s/n 01181)
28	1	76.87.0048	Extension Tube P140 (Before s/n 01181)
28	1	76.87.0049	Extension Tube P165 (Before s/n 01181)
28	1	76.87.0083	Extension Tube P185 (Before s/n 01181)
28	1	76.87.0050	Extension Tube P205 (Before s/n 01181)
28	1	76.87.0109	Extension Tube P120 (After s/n 01182)
28	1	76.87.0110	Extension Tube P140 (After s/n 01182)
28	1	76.87.0111	Extension Tube P165 (After s/n 01182)
28	1	76.87.0112	Extension Tube P185 (After s/n 01182)
28	1	76.87.0113	Extension Tube P205 (After s/n 01182)
29	1	74.41.0055	Gasket 0.5
30	1	71.12.0041	Extension Shaft P120
30	1	71.12.0042	Extension Shaft P140
30	1	71.12.0043	Extension Shaft P165
30	1	71.12.0074	Extension Shaft P185
30	1	71.12.0044	Extension Shaft P205
31	3	80.Z.30.008	Washer D.8
32	1	35X47X7	Oil Seal Thru Shaft
33	1	76.75.0032	Pinion Gear Z14
34	1	30210	Bearing (Before s/n 01181)
34	1	2210-EC	Bearing (After s/n 01182)
35	1	72.41.0013	Complete Gearbox
36	1	72.41.0012	Transmission Assembly P120
36	1	72.41.0014	Transmission Assembly P140
36	1	72.41.0015	Transmission Assembly P165
36	1	72.41.0020	Transmission Assembly P185
36	1	72.41.0016	Transmission Assembly P205

GEARBOX ASSEMBLY 4 SPEED "PC"

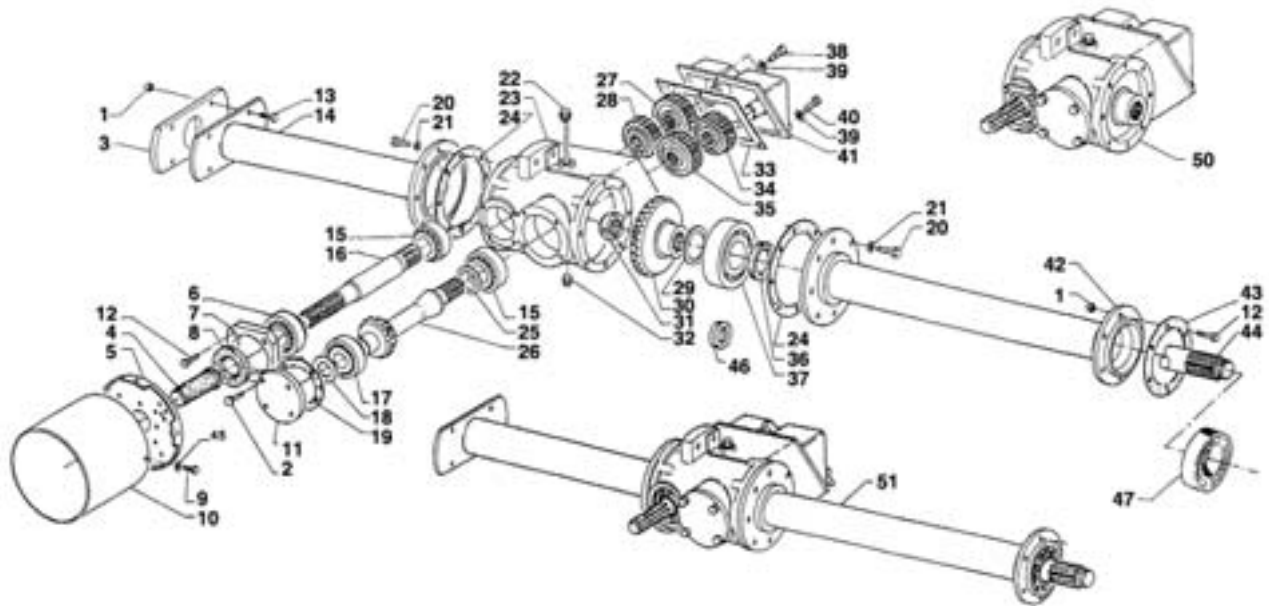

<u>REF#</u>	<u>QTY.</u>	<u>PART NO.</u>	<u>DESCRIPTION</u>
1	10	80.Z.11.012	Nut M10
2	8	80.R.03.136	Bolt M10 x 25
3	1	78.28.0001	Spacer
4	1	80.P.09.001	Cover, Rubber
5	1	78.48.0111	Support Plate
6	1	30207	Bearing 35 - 72 - 18.25
7	1	72.44.0021	Front Cover
8	1	35X62X8	Oil Seal 35 x 62 x 8
9	3	80.Z.03.110	Wing Bolt M8 x 20
10	1	72.48.0004	PTO Shield
11	1	72.44.0002	Cover
12	6	80.Z.03.137	Bolt M10 x 30
13	4	80.Z.03.139	Bolt M10 x 40
14	1	76.87.0085	Spacer P120
14	1	76.87.0072	Spacer P140
14	1	76.87.0073	Spacer P165
14	1	76.87.0074	Spacer P185
14	1	76.87.0076	Spacer P205
15	2	30307	Bearing 35 - 80 - 22.75
16	1	71.12.0031	Input Shaft
17	1	30308	Bearing 40 - 90 - 25.25
18	1	72.80.0036	Spacer 30.3 x 89.7 x 1
19	1	74.41.0022	Gasket
20	16	80.Z.03.159	Bolt M12 x 30
21	16	80.S.35.112	Lock Washer D.12

GEARBOX ASSEMBLY 4 SPEED "PC"

<u>REF#</u>	<u>QTY.</u>	<u>PART NO.</u>	<u>DESCRIPTION</u>
22	1	80.F.90.920	Breather Plug
23	1	78.04.0004	Housing
24	2	74.41.0021	Gasket
25	1	72.80.0037	Spacer 35 x 45 x 1
26	1	76.75.0031	Pinion Gear & Shaft Z14
27	1	74.80.0008	Gear Z17
28	1	74.80.0009	Gear Z18
29	1	72.80.0035	Spacer 55.3 x 67 x 7
30	1	72.46.0008	Bevel Gear Z23
31	1	80.Z.56.013	Ring Nut 40 x 1.5
32	1	80.F.90.512	Drain Plug 1/2"
33	1	74.41.0017	Gasket
34	1	74.80.0011	Gear Z21
35	1	74.80.0010	Gear Z20
36	1	60X80X10	Oil Seal 60 x 80 x 10
37	1	30211	Bearing 55 - 100 - 22.75
38	1	80.Z.90.066	Wing Bolt M8 x 20
39	3	80.S.35.108	Lock Washer D.8
40	2	80.Z.90.069	Wing Bolt M8 x 35
41	1	72.44.0003	Rear Cover
42	1	76.87.0078	Extension Tube P120 (Before s/n 01181)
42	1	76.87.0079	Extension Tube P140 (Before s/n 01181)
42	1	76.87.0080	Extension Tube P165 (Before s/n 01181)
42	1	76.87.0084	Extension Tube P185 (Before s/n 01181)
42	1	76.87.0081	Extension Tube P205 (Before s/n 01181)
42	1	76.87.0115	Extension Tube P120 (After s/n 01182)
42	1	76.87.0116	Extension Tube P140 (After s/n 01182)
42	1	76.87.0117	Extension Tube P165 (After s/n 01182)
42	1	76.87.0118	Extension Tube P185 (After s/n 01182)
42	1	76.87.0119	Extension Tube P205 (After s/n 01182)
43	1	74.41.0055	Gasket 0.5
44	1	71.12.0046	Extension Shaft P120
44	1	71.12.0047	Extension Shaft P140
44	1	71.12.0048	Extension Shaft P165
44	1	71.12.0075	Extension Shaft P185
44	1	71.12.0049	Extension Shaft P205
45	3	80.Z.30.008	Washer M8
46	1	72.80.0025	Spacer 50 - 60 - 23
47	1	30210	Bearing 50 - 90 - 21.75 (Before s/n 01181)
47	1	2210-EC	Bearing 50 - 90 - 23 (After s/n 01182)
50	1	72.39.0014	Gearbox Assembly less Extension Shafts
51	1	72.39.0019	Complete Gearbox P120
51	1	72.39.0020	Complete Gearbox P140
51	1	72.39.0021	Complete Gearbox P165
51	1	72.39.0023	Complete Gearbox P185
51	1	72.39.0022	Complete Gearbox P205

PTO DRIVELINE ASSY 80.A.10.608

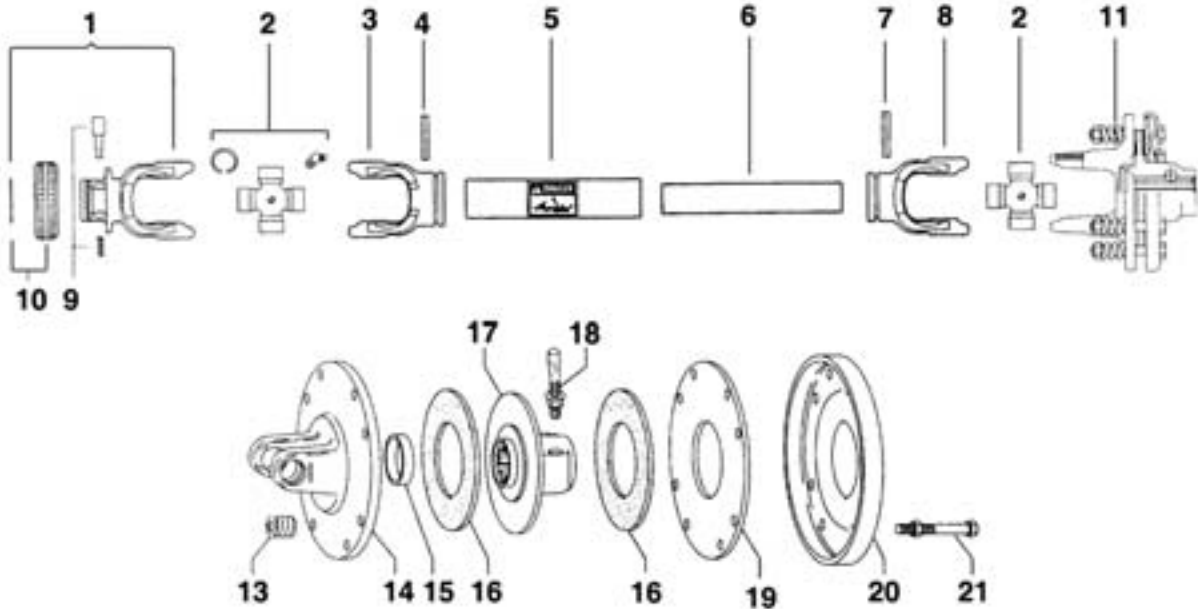

REF#	QTY.	PART NO.	DESCRIPTION
1	1	5720H0376	Yoke 1-3/8" 6-Spline Ball Collar
2	2	41206	Cross Journal Kit #6
3	1	204066851	Yoke, Outer Tube
4	1	341042000	Roll Pin O.T.
5	1	125120860	Tube,Outer Drive
6	1	125090860	Tube, Inner Drive
7	1	341043000	Roll Pin I.T.
8	1	204066852	Yoke, Inner Tube
9	1	403000001	Pin Kit
10	1	240003051	RS Collar Kit
11	1	639248001	Slip Clutch Assembly FF-2
12	1	5N06086N1	Complete Shield (not shown)
13	8	351013370	Spring 7mm
14	1	253062302	Flanged Yoke
15	1	258005320	Bushing
16	2	247000061R08	Lining 160mm x 97mm
17	1	515210311	Hub 1-3/8" 6-Spline
18	1	408000060	Threaded Bolt Assembly
19	1	248230002	Pressure Plate
20	1	248230006	Cover
21	8	432000006	Bolt & Nut

LIMITED WARRANTY



GEARMORE, INC., warrants each new Gearmore product to be free from defects in material and workmanship for a period of twelve (12) months from date of purchase to the original purchaser. This warranty shall not apply to implements or parts that have been subject to misuse, negligence, accident, or that have been altered in any way.

Our obligation shall be limited to repairing or replacement of any part, provided that such part is returned within thirty (30) days from date of failure to Gearmore through the dealer from whom the purchase was made, transportation charges prepaid.

This warranty shall not be interpreted to render us liable for injury or damages of any kind or nature, direct, consequential or contingent, to person or property. This warranty does not extend to loss of crops, loss because of delay in harvesting or any other expenses, for any other reasons.

Gearmore in no way warrants engines, tires, or other trade accessories, since these items are warranted separately by these respective manufacturers.

Gearmore reserves the right to make improvements in design or changes in specification at any time, without incurring any obligations to owners or units previously sold.

GEARMORE, INC.
13477 Benson Ave.
Chino, CA 91710

Always refer to and heed machine operating warning decals on machine.

The serial number of this product is stored in our computer database, thus submitting a warranty registration card is not required.