

GEARMORE INC.

SEEDER / SPREADER TRAILER MOUNTED

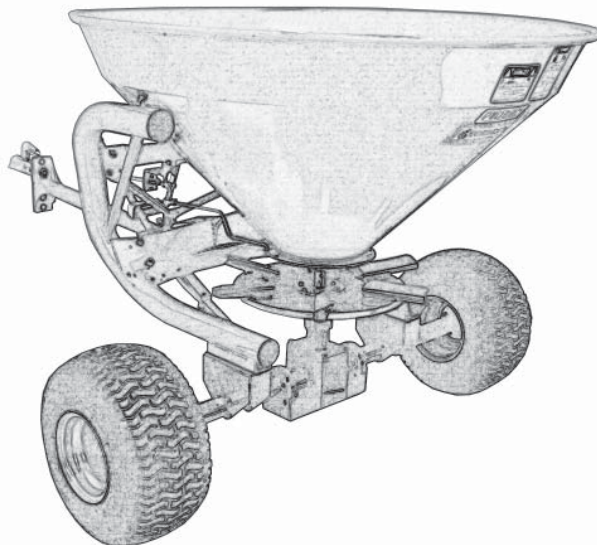

**Operation, Service
& Parts Manual
For Model PTB560**

June 2011

TABLE OF CONTENTS

SECTION	DESCRIPTION	PAGE
1	Introduction	1
2	Preparation.....	2
2.1	Retail Customer's Responsibility.....	2
3	Important Safety Information.....	3 - 5
3.1	Safety Symbols.....	3
3.2	General Advice.....	4 - 5
4	General Information	6 - 7
4.1	Machine Information	6
4.2	Name Plate.....	6
4.3	Machine Features	6 - 7
5	Fertilizer Spreader Use	8 - 9
5.1	Recommendations For Effective Distribution.....	8
5.2	Connections	8
5.3	Machine Function	9
5.4	Machine Transportation.....	9
6	Adjusting The Spread	10 - 12
6.1	Distributor Vane Adjustments.....	10
6.2	Fertilizer Distribution In The Field	11
6.3	Regulating The Distribution.....	12
6.4	Hopper Loading.....	12
6.5	Spreading Chart.....	13
7	Field Spreading.....	14
8	Maintenance & Lubrication	15 - 16
8.1	Lubrication.....	15
8.2	Distribution Errors.....	16
9	Parts Breakdown.....	17 - 21
10	Limited Warranty	22

1 INTRODUCTION

We would like to thank you for purchasing a Gearmore product and we assure you that you have made a good choice, as now you have a very high quality machine. Please follow all instructions contained in this manual for a long and trustworthy machine life.

Know your controls. Read this manual and the manual provided with your tractor before operating your equipment. Keep this manual handy for ready reference. Learn how to stop the tractor engine and spreader quickly in case of an emergency. **DO NOT** allow adults without proper instructions or children to operate machinery. Require all operators to read this manual carefully and become acquainted with all adjustments and operating procedures before attempting to operate the equipment. Replacement manuals can be obtained from your selling dealer.



It is IMPORTANT to read this manual carefully before operating the spreader!

The equipment you have purchased has been carefully engineered and manufactured to provide dependable and satisfactory use. Like all mechanical products, it will require cleaning and upkeep. Lubricate the unit as specified. Please observe all safety information in this manual and safety decals on the equipment.

For service, your authorized dealer has trained mechanics, genuine service parts, and the necessary tools and equipment to handle all of your service needs.

Use only genuine service parts. Substitute parts will void the warranty and may not meet standards required for safe and satisfactory operation. Record the model number and serial number of your equipment in the warranty page of this manual.

Throughout this manual, the term **IMPORTANT** is used to indicate that failure to observe procedures can cause damage to equipment. The terms **CAUTION**, **WARNING** and **DANGER** are used in conjunction with the Safety-Alert Symbol, (a triangle with an exclamation mark), to indicate the degree of hazard for items of personal safety.



This Safety-Alert Symbol indicates a hazard and means ATTENTION! BECOME ALERT! YOUR SAFETY IS INVOLVED!



DANGER

Indicates an imminently hazardous situation that, if not avoided, will result in death or serious injury.



WARNING

Indicates a potentially hazardous situation that, if not avoided, could result in death or serious injury, and includes hazards that are exposed when guards are removed.



CAUTION

Indicates a potentially hazardous situation that, if not avoided, may result in minor or moderate injury.

IMPORTANT

Indicates that failure to observe can cause damage to equipment.

NOTE

Indicates helpful information.

2 PREPARATION CHECKLIST



THIS CHECKLIST TO REMAIN IN OWNER'S MANUAL

IT IS YOUR RESPONSIBILITY TO COMPLETE THE PROCEDURES LISTED

BELOW BEFORE OPERATING THE SPREADER

Preparation Check List

- 1. Implement is completely assembled.
- 2. Inspect for damage and loose or missing parts
- 3. All decals in place and readable.
- 4. All fittings and drive components are secure.
- 5. Overall condition good.
- 6. Check hopper for any foreign objects.
- 7. Operator has been instructed on the safe and proper use of the implement.
- 8. Lubrication - See *Lubrication & Maintenance* Section

The purpose of this manual is to assist you in operating and maintaining your spreader for years of service. Read it carefully. The information and instructions in this manual have been compiled from extensive field experience and engineering data. Some information may be general in nature due to unknown and varying operating conditions. However, through experience and these instructions, you should be able to develop procedures suitable to your particular situation.

The illustrations and data used in this manual were current at the time of printing, but because we maintain an ongoing program of product improvement, we reserve the right to make improvements in design or changes in specifications without incurring any obligation to install them on units previously sold. Because of the possibility that some photographs in this manual were taken of prototype models, production models may vary in some detail.

All information, illustrations and specifications in this manual are based on the latest information available at the time of publication. The right is reserved to make changes at any time without notice.

2.1 RETAIL CUSTOMER'S WARRANTY RESPONSIBILITY

It is the Retail Customer and/or Operator's responsibility to read the Operator's Manual, to operate, lubricate, maintain and store the product in accordance with all instructions and safety procedures. Failure of the operator to read the Operator's Manual is a misuse of this equipment. It is the Retail Customer and/or Operator's responsibility to inspect the product and to have any part(s) repaired or replaced when continued operation would cause damage or excessive wear to other parts or cause a safety hazard. It is the Retail Customer's responsibility to deliver the product to the authorized dealer from whom he purchased it, for service or replacement of defective parts which are covered by warranty. Repairs to be submitted for warranty consideration must be made within thirty (30) days of failure. It is the Retail Customer's responsibility for any cost incurred by the dealer for traveling to or hauling of the product for the purpose of performing a warranty obligation or inspection.

3 SAFETY INFORMATION

3.1 SAFETY SYMBOLS



ATTENTION!

Be sure that the safety labels are readable. Clean them up using a cloth, water and soap. Replace the damaged labels placing them in the right position, as subsequently described.

The safety symbols applied to the machine provide a series of very important information; which needs to be followed to assure your safety.



1. ATTENTION! Before performing any operation on the machine, stop the tractor motor, remove the key from the ignition, engage the parking brake, and read the user and maintenance manual.



2. IMPORTANT! - DANGER! Risk of launch material and/or objects, do not remain near or approach the machine. Keep a minimum safety distance of 50 meters from the machine.



3. IMPORTANT! - DANGER! Do not enter in the hopper or ride on the machine.



7. ATTENTION! Use the individual Protection Devices, as required.

Symbol location on the machine

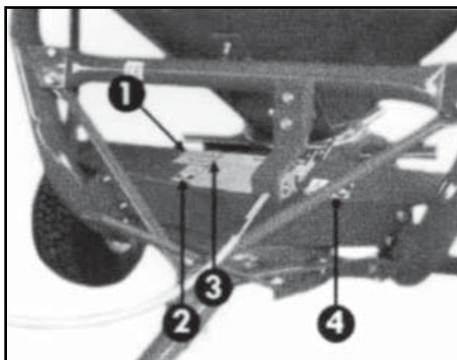

3 SAFETY INFORMATION (Continued)

THE FOLLOWING SAFETY RECOMMENDATIONS ARE TO PROTECT YOU FROM INJURY; IT IS THEREFORE IMPORTANT TO READ THEM CAREFULLY, MEMORIZE THEM AND ALWAYS APPLY THEM.

The warnings indicated in this manual regard exclusively the allowed uses and reasonably foreseeable. These instructions must always be followed, in accordance with the good sense and experience of the operator as they are essential to prevent accidents.

The machine must be used by a single operator. It is forbidden for use by under age individuals.

All the instructions provided must be followed carefully.

Possible changes on the machine, not preventively authorized by the manufacturer (by written copy), exclude his responsibility.

Check the correct functioning of the machine, before each use.

3.2 GENERAL ADVICE

- Read this manual carefully before proceeding to start, operate, employ, or perform maintenance on the machine.
- Follow all the warnings in this manual, as well as all the general safety and accident prevention information.
- The manual must always be handy, so as to consult it in order to check working cycle and safety information. In case of loss or damage, it will be necessary to ask for a replacement copy.



ATTENTION! Any maintenance, adjustment, and cleaning operations should be done with the machine on the ground (in stable conditions), with the tractor motor off, hand brake engaged, ignition key off and removed from the ignition panel.

- Read carefully the safety signal words applied on the machine and follow the instructions. In case of wear and tear or insufficient readability of the safety signal words, clean them up or replace them, placing the signal words in the right position, as shown on page 3.

ATTENTION! - WARNING!

The operator, during the period of use, maintenance, repair, handling or storing of the machine, must wear accident prevention shoes and safety gloves. Moreover, if it is necessary he must wear suitable hearing protections such as earmuffs or earplugs, dust masks and protective glasses.



- During loading phase, there is the danger of powder inhalation produced by fertilizer mixing. We recommend the use of tractors with cab fitted with ventilation systems or suitable means of protection of the airways, such as dust protection masks or masks with filter.

3 SAFETY INFORMATION (Continued)

- The machine is designed for being used by a single operator who, during the use, must always stay in the stationing control on the tractor.
- Never work with this machine if you are tired, sick or after having taken alcohol, drugs or medicines.



DANGER!

It is forbidden to climb or to transport somebody when the machine is in motion. Do not get in the hopper for any reason. Do not ride on implement.

- Keep the machine free of any objects (debris, tools, dirt, various objects), as they could damage the operations or the operator. Generally the fertilizers are rather corrosive. For this reason, it is important that any particle of the fertilizer stay in the machine for a long period of time. Clean the hopper and the distributor after each use of the machine.
- If during cleaning operations air or water with pressure is used, it is necessary to wear glasses and safety masks keeping all persons and animals away from the machine.
- Before connecting the machine to the tractor or to other self-moving means check that this is in good condition and that the brakes work correctly, especially if you work on sloping grounds.
- Detach the machine from the tractor only on a compact and level ground (with empty hopper), checking that the machine is stable.



WARNING!

During transport operations, stocking and employment of the fertilizers, the operators must follow all the label indications and particularly to the content of the written risks and the precaution suggestions.



ATTENTION!

The manufacturer is not responsible for damages caused by improper and unforeseen use of the machine.

The Manufacturer is not responsible in case of:

- ~ Improper use of the machine, use by untrained staff.
- ~ Serious lack of maintenance.
- ~ Non-authorized modifications or interventions.
- ~ Use of not original or specific spare parts.
- ~ Total or partial inobservance of the instructions.
- ~ Inobservance of the common safety rules during work.

4 GENERAL INFORMATION

4.1 MACHINE INFORMATION

The machine model shown in this manual has been designed and made exclusively to undertake the distribution of solid, granular fertilizer and seed. The machine is not designed for non agricultural uses.

This machine is usually used during the day. If it is required to use the machine in night time or with poor visibility, it will be necessary to use the lighting system of the tractor.

4.2 NAME PLATE

On the frame of each machine is fixed a plate showing the CE mark, the model, the serial number, and the year of construction of the machine.

When spare parts are required, it is always necessary to refer to the type of the machine, the frame number and year of construction.



Plate position on the machine

4.3 MACHINE FEATURES

The great spreading precision of this spreader provides use in different applications, both for gardening and in golf courses.

Thanks to the wide tires and to the low height of the hopper, they can be used by everybody with easy access.

The painting of the frame, is made by a water base varnish with successive backing at 150° with the application of the primer bath, assuring a great protection and long life of the machine.

4 GENERAL INFORMATION (Continued)

The PTB fertilizer spreader is characterized by a spreader device in stainless steel equipped with a spreader disc with six fins adjustable in three different positions, in order to obtain the maximum precision and uniformity spreading according to the type of product to be spread.

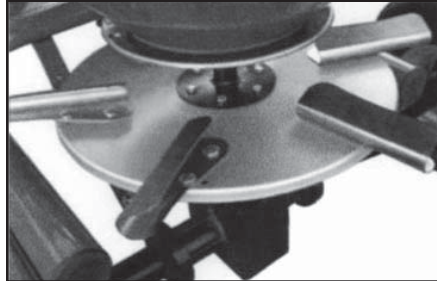

Distributor Disc

The feeding of the disc is by gravity through two shutters located on the bottom of the hopper, inside of which an agitator is applied in order to prevent the formation of fertilizer lumps. In some cases it is necessary to assemble a chain agitator (optional) in order to improve the fertilizer spreading.

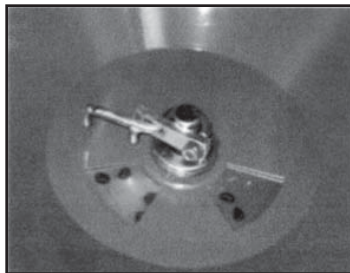

Standard Agitator

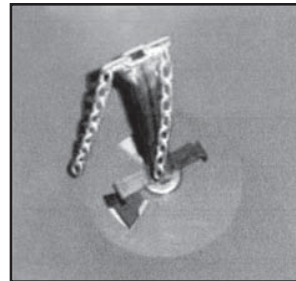

Chain Agitator

A protection sheet is located in front of the disc in order to prevent spreading in the front part of the machine.

The amount of the fertilizer to distribute is regulated by the opening width of the exits on the hopper by a flexible cable lever (to be placed by the vehicle operator).

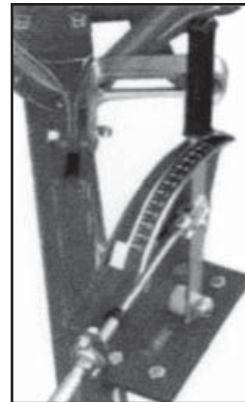

Flexible Cable Lever

5 SPREADER USE



IMPORTANT!

Check that the transmission element is sufficiently lubricated before use.



IMPORTANT!

When using the machine, assure that there are no animals or people present within a radius of 50 feet. Should anyone approach, immediately stop working and switch off the tractor engine.

5.1 RECOMMENDATIONS FOR EFFECTIVE DISTRIBUTION

- Always undertake a test on the lbs/acre to be distributed before beginning operations.
- Always make sure that the fertilizer used is in good conditions; damp fertilizer cannot be correctly and evenly distributed.
- Only open the gates when the required speed has been reached.
Avoid distributing the fertilizer on land that is constantly exposed to the wind to assure even distribution.

5.2 CONNECTIONS

Model PTB spreader can be hitched to all kinds of tractors or ATV/Quad vehicles fitted with 50 mm ball attachment (1 7/8").

For the purposes of connection, insert the ball attachment into the towing hook on the towing vehicle and secure it by pressing the locking handle downwards.

IMPORTANT - ADJUST THE ATTACHMENT HEIGHT OF THE TOW BAR (IN THE FOUR RELATIVE POSITIONS), SO THAT THE DISTRIBUTOR DISC IS AS PARALLEL AS POSSIBLE TO THE GROUND, TO ASSURE EVEN REGULAR FERTILIZER DISTRIBUTION.

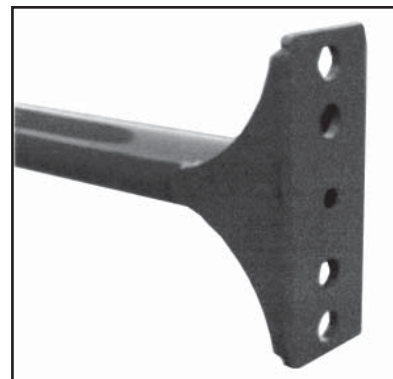

Tow-Bar Height Adjustment Slots

5 SPREADER USE (Continued)

5.3 MACHINE FUNCTION

- Always check the machine before starting up. Only begin working if the machine is in perfect condition.
- Before using the machine assure that all the safety devices are correctly placed and in good condition. In case of any damage to the protections, they must be immediately replaced.



IMPORTANT!

During operation insure that there are no animals or people within 50 ft. When you work near roads or public places it is **COMPULSORY** to keep people away and increase precautions.



IMPORTANT!

Anyone that approaches the machine is in a danger area, and he becomes an "EXPOSED PERSON". The operator must prevent anyone from coming into a danger area and work with the maximum caution. If somebody comes up, stop the tractor engine.

- Before using the spreader always check the state of wear of the vanes of the distributor disc. Check that fixture elements (screws and nuts) are in and fixed.
- Always keep the machine in good operating conditions and make regular maintenance.

5.4 MACHINE TRANSPORTATION



IMPORTANT!

Always follow the highway code applicable in the country of use.
Always empty the hopper before transporting on public roads.

As well as respect for the regulations, it must be remembered that during moving on public roads particular attention should be paid to the instructions indicated in the circulation handbook of the tractor, and in the selection of the suitable transfer speed especially in the case of crowded, winding or steep roads.

Should the dimensions of the spreader conceal the rear indicator lights of the towing vehicle, a hazard light bar should be applied or rear signs. On entering a road after operating, attention should be taken to clean the tires or the operating elements to prevent soiling the road surface with dirt or other material.

The wheels must be disengaged during transport. Disconnect the mechanical stop from the wheel axle by rotating the transmission attachment/disconnection lever.

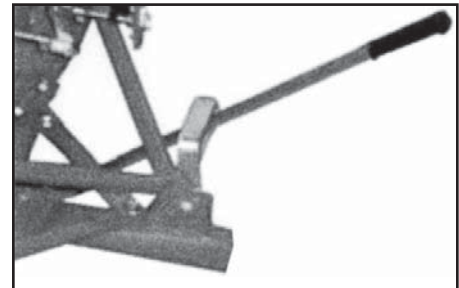

Distributor Engagement Lever

6 ADJUSTING THE SPREAD

It is not possible to establish an exact spreading chart for equipment that make use of the centrifugal principle, as the distributed quantity depends on the speed, on the radius of distribution, on the quality and humidity of the fertilizer and the ground conditions.

The fertilizer must always be stored and conserved adequately, so as to keep its physical features. It is important to set the speed of the towing vehicle before starting the distribution operation, and trying to keep it constant for all its duration.

The spreading charts just contain the indicative information, in order to determine the quantity to spread in the fields; these must be completed by the experience and the competence of the operator.

6.1 DISTRIBUTOR VANE ADJUSTMENTS

The distributor disc is equipped with six adjustable vanes that can be adjusted to three different positions. The spreader is delivered with the fins in central position "2" which has been found to be the ideal position to assure the uniformity in distribution for most of the fertilizers on the market.

If you notice a not uniform fertilizer spreading (more from one side than the other), it will be necessary to move the distributor vanes until the right adjustment is achieved. Generally it is sufficient just move the two opposite vanes to obtain good results.

If the mentioned adjustment was not sufficient set the same adjustment on the other opposite vanes. For example, if you notice a greater spreading on the left side (in relation to the advance direction of the machine), shift the two opposing vanes in the slot to position "3". If the spreading is not yet uniform even after this adjustment, move in position "3" other two opposite vanes.

If the fertilizer distribution is greater on the right side, shift the vanes to position "1".

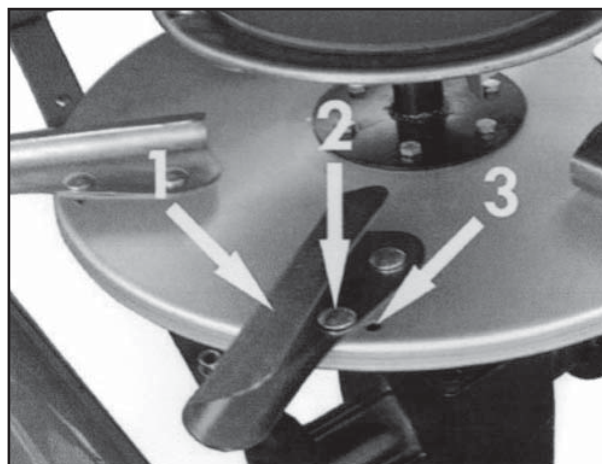

Distributor Disc Vanes Adjustment

6 ADJUSTING THE SPREAD (Continued)

6.2 FERTILIZER DISTRIBUTION IN THE FIELD



CAUTION! - WARNING!

The operator, during the period of use, maintenance, repair, transport or storing of the machine, must wear accident-prevention shoes and gloves of security. If it is necessary, he will have, moreover, to wear headset, mask, and glasses.

After connecting the machine to the tractor and adjusting as required, it will be possible to begin to work.



WARNING!

Before getting off from the spreader and before every operation of maintenance and regulation, set in action the parking brake, turn off the engine, remove the ignition key from the dashboard and wait for all moving parts to come to a stop.

The spreader is drive wheel operated. "**IMPORTANT**" - only engage the drive wheels when stopped. When transporting disengage the drive wheel.

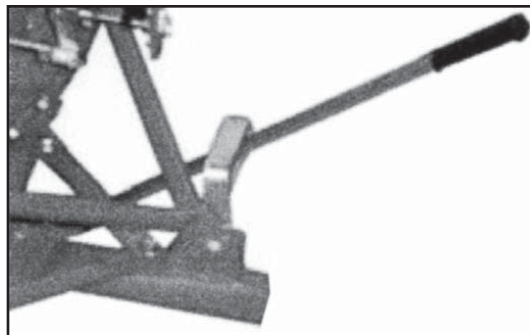

Distributor Engagement Lever

6 ADJUSTING THE SPREAD (Continued)

6.3 REGULATING THE DISTRIBUTION

The fertilizer distribution is regulated through the regulation lever that moves the opening section on the bottom of the hopper.

In order to carry out the regulation, after having consulted the spreading chart that is visible on the hopper of the spreader, according to the type of product and the drive speed, it is sufficient move the lever "A" along the graduated scale "B" in the required position.

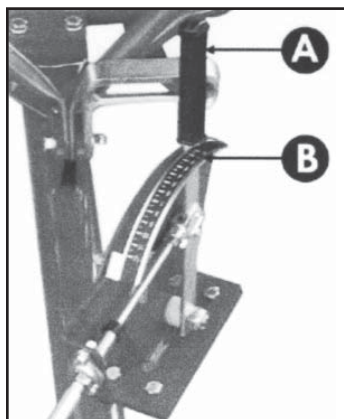

Distribution Adjustment Lever

SPREADING CHART FOR FERTILIZER		SPREADING CHART FOR SEED	
TRACTOR MODEL	DRIVE SPEED (km/h)	TRACTOR MODEL	DRIVE SPEED (km/h)
LAPIDE	10.0	100	10.0
UNIVERSAL	12.0	120	12.0
PORTAFERTILIZ.	15.0	150	15.0
PRELIM.	18.0	180	18.0
UNIVERSAL	20.0	200	20.0
PORTAFERTILIZ.	25.0	250	25.0
PRELIM.	30.0	300	30.0
UNIVERSAL	35.0	350	35.0
PORTAFERTILIZ.	40.0	400	40.0
PRELIM.	45.0	450	45.0
UNIVERSAL	50.0	500	50.0
PORTAFERTILIZ.	55.0	550	55.0
PRELIM.	60.0	600	60.0
UNIVERSAL	65.0	650	65.0
PORTAFERTILIZ.	70.0	700	70.0
PRELIM.	75.0	750	75.0
UNIVERSAL	80.0	800	80.0
PORTAFERTILIZ.	85.0	850	85.0
PRELIM.	90.0	900	90.0
UNIVERSAL	95.0	950	95.0
PORTAFERTILIZ.	100.0	1000	100.0

*Spreading Chart
(See Page 13)*

6.4 HOPPER LOADING

We do not recommend that the hopper be loaded manually, but by using a lift device or suitable mechanical devices.



IMPORTANT!

The hopper must be loaded only after the spreader has been connected to the tractor.

Before loading the hopper, the shutters must be closed; position the distribution adjustment lever in position "0".

Do not drive for very long distances with a full load and do not put full bags of the fertilizer loaded in the hopper during the transport to the field or during the working, in order not to overload the capacity of the machine and to compress the fertilizer.



WARNING! During the operation of transport, stock and use of fertilizers, the operator must behave in compliance with the indications on the label of the product and in particular with the content of the sentences of risk and the precaution advices.

6.5 SPREADING CHART

SPREADING CHART

SPREADING CHART FOR FERTILIZER												SPREADING CHART FOR SEED											
TRACTOR SPEED (MPH)	SPREAD WIDTH (FEET)	QUANTITY SPREAD IN LBS/ACRE AT VARIOUS GATE SETTINGS										TRACTOR SPEED (MPH)	SPREAD WIDTH (FEET)	QUANTITY SPREAD IN LBS/ACRE AT VARIOUS GATE SETTINGS									
		3	4	6	8	9	10	11	12	9	10			11	12								
LARGE GRANULAR FERTILIZER	3.0	132	197	401	750	927	998	1052	1137	WHEAT	3.0	60	19	36	77	108							
GRANULAR FERTILIZER	5.0	60	66	99	200	376	464	498	569	ALFALFA & CLOVER	5.0	36	65	102	190	258							
FERTILIZER	7.5	44	66	134	251	310	333	351	379	FESCUE & RYEGRASS	7.5	36	39	61	114	156							
MEDIUM GRANULAR FERTILIZER	3.0	-	275	447	788	923	999	1048	1116	RED CLOVER	3.0	23	-	-	47	64							
GRANULAR FERTILIZER	5.0	50	139	223	394	462	501	524	558	KENTUCKY GRASS & BERMUDA GRASS	5.0	36	67	101	188	257							
FERTILIZER	7.5	-	93	149	263	309	335	350	372	SUDAN GRASS	7.5	36	28	44	81	110							
FINE GRANULAR FERTILIZER	3.0	112	158	321	613	746	814	881	961	BARLEY	3.0	46	10	20	52	75							
GRANULAR FERTILIZER	5.0	40	56	80	166	307	373	408	441	481	RYE	5.0	46	10	20	52	75						
FERTILIZER	7.5	36	53	110	205	248	271	294	320														
CRYSTAL (AMMON. SULPHATE)	3.0	225	313	559	1023	1234	1329	1404	1519														
THOMAS MEAL (BASIC SLAG)	5.0	23	113	157	279	511	617	665	702	759													
	7.5	75	105	187	341	411	443	468	506														
	4.0	20	-	-	570	1125	1266	1406	1540	1679													
	8.0	-	-	-	285	562	633	703	770	885													

7 FIELD SPREADING



Various ways exist to spread the fertilizer in the field. One of the simplest methods is as follows:

1. Position the *ATV/tractor* at the beginning of the field you intend to fertilize, to a distance ($D/2$) that is half of the working width that is used (point 1).
2. Drive into the field distributing the fertilizer on all the perimeter.
3. Stop the tractor at one distance (D) from the point 1, equivalent to the set working width (point 2).
4. Begin the spreading proceeding in line, straight to point 3.
5. Turn the tractor and drive a D distance, equal to the working width (point 4).
6. Repeat such procedure until all the plot will be covered.

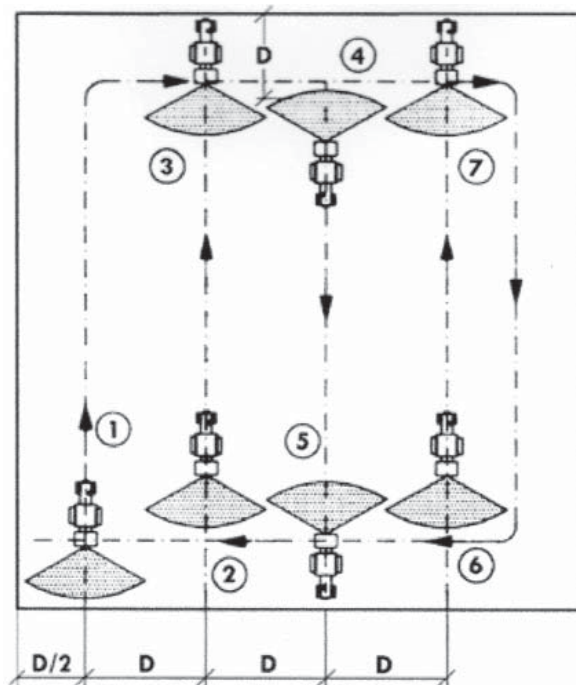

8 MAINTENANCE & LUBRICATION



WARNING!

All maintenance, regulation and cleaning operations are to be carried out with tractor engine off, hand brake engaged, and ignition key removed from the starter panel.

In the event of any faults the operator must immediately stop the machine, assess the extent of the problem and proceed with any action that may be required.

Should pressurized water or compressed air be used to clean the machine, it is important to protect oneself using special goggles or masks, and to make sure that no persons or animals are in the vicinity of the machine. Do not use inflammable liquids.



WARNING! Always use suitable individual protection means for all maintenance operations (safety footwear and work gloves) and ensure that all accident prevention precautions are taken for the operation underway.

Every 8 working hours check the tightness of all the nuts and bolts.

In case of vibrations, verify the status of the vanes of the spreading disc, the correct tightness of all the nuts and bolts and the lubrication of the gearbox.

The excessive vibration of the machine, besides the specific annoyance, is dangerous and damaging for the entire structure subjecting the mechanical parts to more and more stress cycles compared to the advice pictures.

8.1 LUBRICATION

This spreader was developed so that there is only one lubrication point, the gearbox.

Every 40 hours of use you should check the oil level in the gearbox. If oil level is low, add using 90 wt. oil. Gearbox capacity is .84 QRB.



Note: If desired, lithium multi-purpose grease can be used instead of 90 wt. oil.

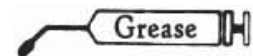

8 MAINTENANCE & LUBRICATION (Continued)

8.2 DISTRIBUTION ERRORS

Operating Errors:

- Unsuitable forward speed
- Incorrect distribution width
- The distributor disc is not horizontal in relation to the ground
- Advance speed differing to that prescribed in the distribution tables, or unsuitable for the particular material concerned
- Driving errors (no overlap of the spreading surfaces)
- Failure to clean the distributor disc and hopper openings.

Fertilizer Errors:

- Fertilizer of inferior quality
- Fertilizer is either wet or too damp
- The material composition is incorrect or fails to correspond to that declared by the seller
- Presence of excessive granules or of excessively large size that impede distribution
- Foreign bodies inside the fertilizer

Machine Errors:

- Hopper openings blocked
- Parts of the distribution disc that are either worn or damaged

9 PARTS BREAKDOWN

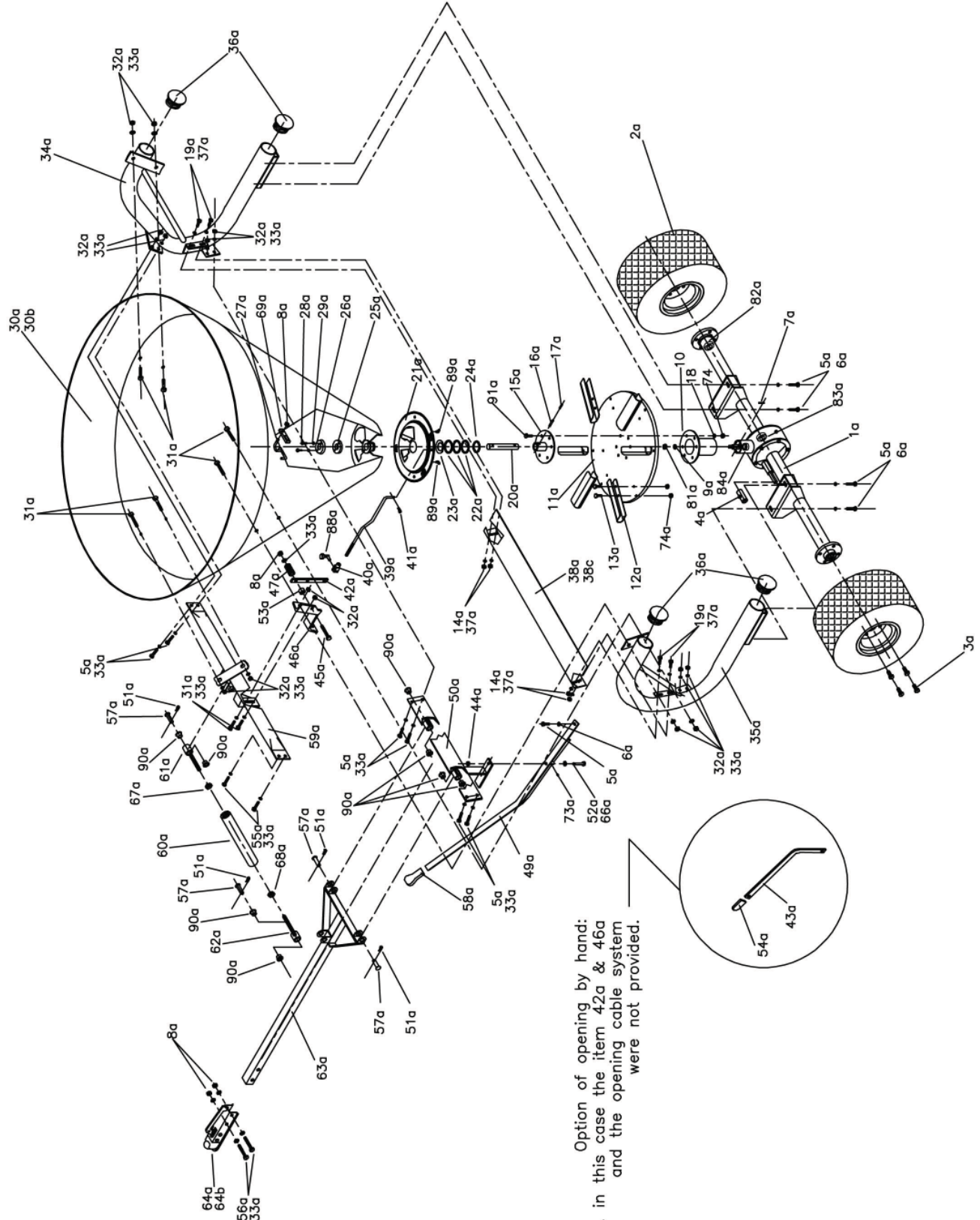

Option of opening by hand:
 N.B. in this case the item 42a & 46a
 and the opening cable system
 were not provided.

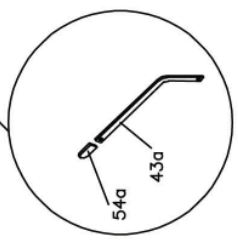

9 PARTS BREAKDOWN (Continued)

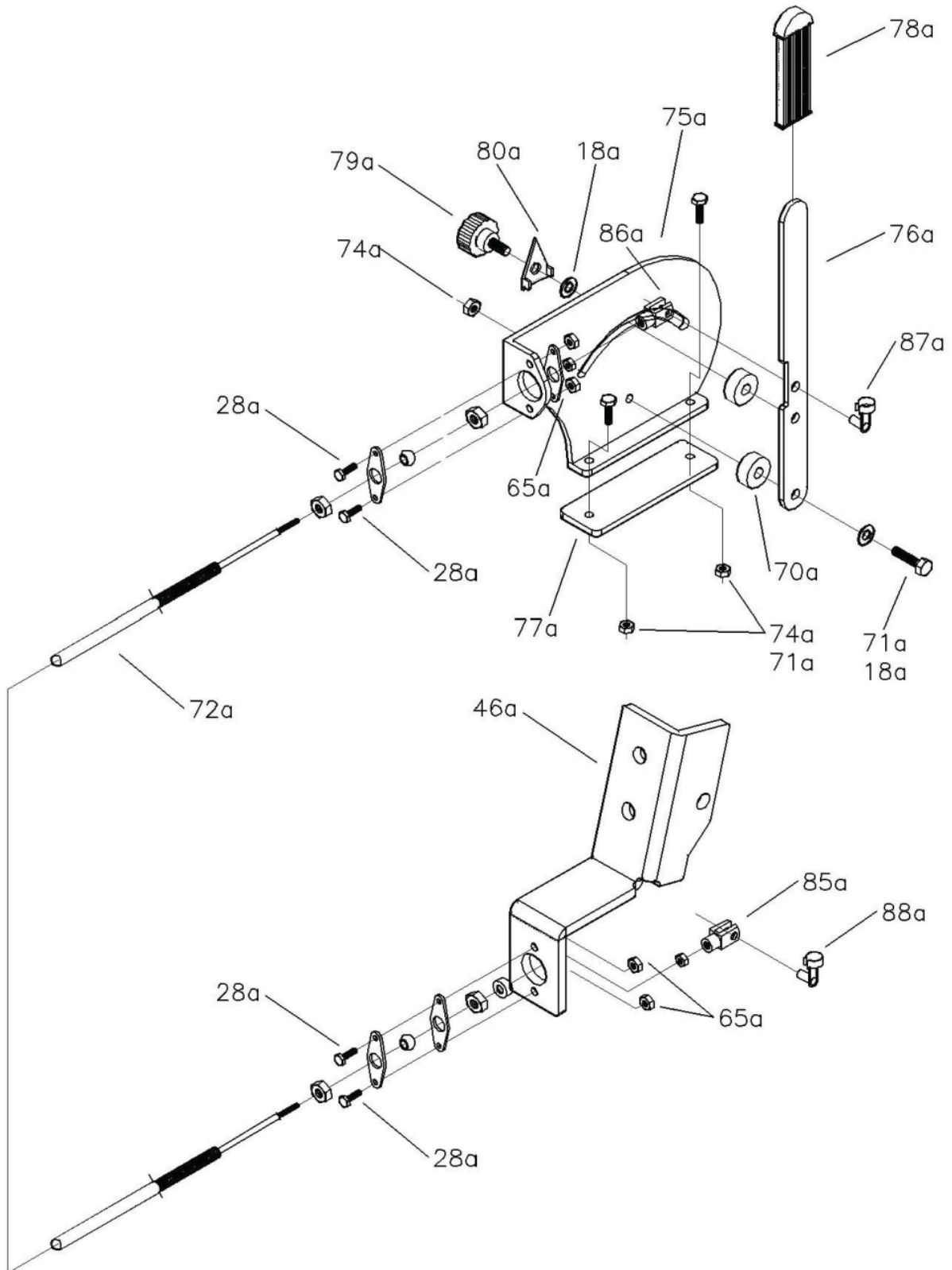

9 PARTS BREAKDOWN (Continued)

<u>REF #</u>	<u>QTY.</u>	<u>PART NO.</u>	<u>DESCRIPTION</u>
1a	1	620.037	Axle w/Bushing
2a	2	620.007	Wheel 20 x 10.00 - 8 D266
3a	8	300.006	Hexagonal Head Screw 12 x 30
4a	1	325.017	Release Bushing
5a	9	300.003	Hexagonal Head Screw 10 x 25
6a	5	303.025	Washer 10 x 30
7a	1	326.007	Key 6 x 6 x 30
8a	4	301.013	Self Locking Nut M10
9a	1	303.019	Washer 14 x 42 x 3
10a	1	325.018	Rotary Bushing
11a	1	610.043	S.S. Spreading Disc
12a	6	601.026	Stainless Steel Vane
13a	12	300.107	S.S. Cup Square Screw 8 x 16 (QH3 UNI 5731)
14a	4	301.012	Galvanized Nut M8
		610.044	S.S. Spreading Disc w/S.S. Vanes & Bolts & Nuts
15a	1	325.001	Disc's Upper Bushing
16a	1	305.001	Spring Pin 8 x 40
17a	1	305.003	Spring Pin 5 x 40
18a	8	303.007	Galvanized Washer 8 x 17 UNI 6592
19a	4	300.029	Galvanized Hexagonal Head Screw 8 x 20 UNI 5739
20a	1	330.005	Entrainer
21a	1	610.011	Stainless Steel Adjustment Disc
22a	3	303.012	Thickening Washer 56 x 70 x 0.5
23a	1	303.031	Disc Spring 79.5 x 55.5 x 0.8
24a	1	313.012	Retaining Ring M55 UNI 7435
25a	2	304.053	Rubber Washer 5 mm Thick
26a	1	620.009	Metal Ring
27a	1	619.033	Lower Agitator
		619.003	Lower Agitator Kit w/Plate
28a	6	300.037	Galvanized Hex Head Screw 6 x 20 UNI 5739
29a	2	303.014	Galvanized Washer 6 x 12 UNI 6592
30b	1	609.031	Hopper PTB 560
31a	8	300.043	Galvanized Cup Square Screw 10 x 25 UNI 5739
32a	16	301.010	Galvanized Nut M10 5588
33a	29	303.015	Galvanized Washer 10 x 20 UNI 6592
34a	1	613.020	Right Frame Tube
35a	1	613.021	Left Frame Tube
36a	4	612.003	Frame Rubber Cap Dia. 75 mm
37a	8	303.013	Galvanized Washer 8 x 24 UNI 6593
38a	1	639.013	Iron Rear Shield

9 PARTS BREAKDOWN (Continued)

<u>REF #</u>	<u>QTY.</u>	<u>PART NO.</u>	<u>DESCRIPTION</u>
38c	1	639.024	Stainless Steel Rear Shield 15/10 (optional)
39a	1	602.027	Disc Opening Tie Rod w/Washer
40a	1	332.004	Tie Rod Yoke 10 x 20 M10
41a	1	305.008	Bearing R3 ZB
42a	1	620.012	Lever For Cable Opening System
43a	1	620.013	Lever For Manual Opening System
44a	1	301.061	Galvanized Nut M12
45a	1	300.085	Galvanized Hex Head Screw 10 x 90 UNI 5739
46a	1	620.010	Cable Support
47a	1	617.002	Spring 40 x 20 x 10
48a	6	300.050	Galvanized Hex Head Screw 8 x 25 UNI 5739
49a	1	620.067	Release Lever
50a	1	613.050	Lower Crossbar
51a	4	307.001	Split Cotter Pin 4.5 mm
52a	1	300.084	Galvanized Hex Head Screw 12 x 70 UNI 5739
53a	1	325.022	Nylon Bushing M10
54a	1	304.028	Rubber Handle 20 x 10 (Manual Opening System)
55a	4	300.013	Galvanized Hex Head Screw 10 x 30 UNI 5739
56a	2	300.020	Galvanized Hex Head Screw 10 x 70 UNI 5737
57a	4	633.024	Pivot w/Washer
58a	1	304.014	Rubber Handle 30 x 10
59a	1	613.051	Upper Crossbar
60a	1	606.149	Tube Level Stop
61a	1	606.146	Right Tie Rod w/Bushing
62a	1	606.147	Left Tie Rod w/Bushing
63a	1	620.068	Tow Tube
64a	1	620.080	1 7/8" Coupler
64b	1	620.090	2" Coupler
65a	4	301.009	Self Locking Nut M6
66a	1	303.026	Galvanized Washer 13 x 25 UNI 6592
67a	1	301.075	Nut M20 Right Thread
68a	1	301.073	Nut M20 Left Thread
69a	1	619.034	Lower Agitator Plate
70a	2	329.008	Nylon Spacer 9 x 25 x 10
71a	3	300.069	Galvanized Hex Head Screw 8 x 30 UNI 5739
72a	1	620.000	Cable 2200 mm Length
73a	1	306.007	Grease Nipple M6
74a	21	301.001	Self Locking Nut M8
75a	1	603.002	Cable Supporting Plate - Tractor Side
76a	1	604.014	Lever Bracket - Tractor Side
77a	1	603.001	Fixing Support Plate - Tractor Side

9 PARTS BREAKDOWN (Continued)

<u>REF #</u>	<u>QTY.</u>	<u>PART NO.</u>	<u>DESCRIPTION</u>
78a	1	304.015	Rubber Handle 20 x 5
79a	1	302.003	Knob M8 x 25
80a	1	616.004	Adjusting Arrow
81a	1	301.007	Galvanized Self Locking Nut M14
82a	4	310.001	Bearing 6205 2RS 25-52-15
83a	1	310.002	Bearing 6205 25-52-15
84a	2	310.016	Bearing 6304 2RS 20-52-15
85a	1	332.009	Yoke M7 w/10 mm Hole
86a	1	332.010	Yoke M7 w/8 mm Hole
87a	1	332.007	Clips 8 x 19
88a	2	332.006	Clips 10 x 23
89a	2	306.010	Grease Nipple 90° 8 x 1.25 ZA
90a	8	325.024	Flange Bearing
91a	12	301.079	Stainless Steel Self Locking Nut M8

10 LIMITED WARRANTY



GEARMORE, INC., warrants each new Gearmore product to be free from defects in material and workmanship for a period of twelve (12) months from date of purchase to the original purchaser. This warranty shall not apply to implements or parts that have been subject to misuse, negligence, accident, or that have been altered in any way.

Our obligation shall be limited to repairing or replacement of any part, provided that such part is returned within thirty (30) days from date of failure to Gearmore through the dealer from whom the purchase was made, transportation charges prepaid.

This warranty shall not be interpreted to render us liable for injury or damages of any kind or nature, direct, consequential or contingent, to person or property. This warranty does not extend to loss of crops, loss because of delay in harvesting or any other expenses, for any other reasons.

Gearmore in no way warrants engines, tires, or other trade accessories, since these items are warranted separately by these respective manufacturers.

Gearmore reserves the right to make improvements in design or changes in specification at any time, without incurring any obligations to owners or units previously sold.

GEARMORE, INC.
13477 Benson Ave.
Chino, CA 91710

Always refer to and heed machine operating warning decals on machine.

The serial number of this product is stored in our computer database, thus submitting a warranty registration card is not required.

CUSTOMER INFORMATION

NAME: _____

PURCHASED FROM: _____

DATE OF PURCHASE: _____

MODEL NUMBER: _____

SERIAL NUMBER: _____