

GEARMORE INC.

VENTURI AIR SPRAYERS

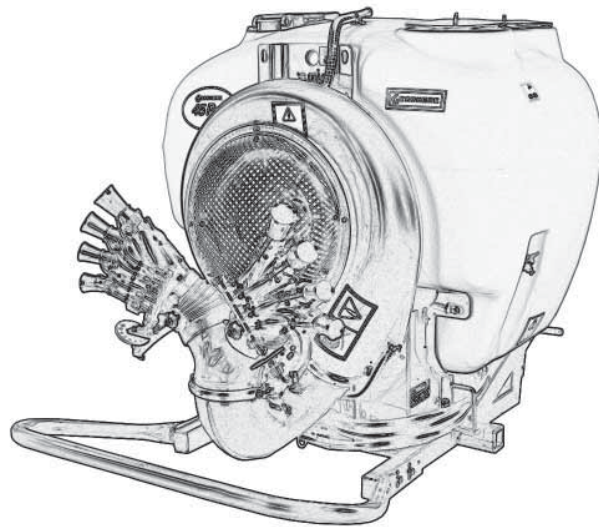

**Parts Manual For
Model P45N1-400-G15
100 Gallon Capacity**

June 2013

TABLE OF CONTENTS

<u>SECTION</u>	<u>DESCRIPTION</u>	<u>PAGE</u>
1	Introduction	1
1.1	Purchaser's Responsibility	1
1.2	Serial Number Information	1
2	Replacement Parts	2 - 31
2.1	Frame Assembly.....	2-3
2.2	Tank & Fittings	4-5
2.3	Hand Cleaner Tank	6-7
2.4	Tank & Fittings	8
2.5	Hand Cleaning Tank & Fittings	9
2.6	Fan Assembly	10
2.7	Fan Support & Belt Tensioner	11
2.8	Fan Support Breakdown.....	12-13
2.9	Tension Roller	14
2.10	Lubrication Tubes.....	15
2.11	Clutch & Pulley	16
2.12	Fan Support Housing.....	17
2.13	Liquid Flow Path	18-20
2.14	Pressure Regulator & 3 Way Valve.....	21
2.15	Inline Filters.....	22
2.16	Pump Assembly	23-24
2.17	Liquid Valves	25-26
2.18	Optional Liquid Valves	27-28
2.19	Optional Control Switch	29
2.20	Drive Assembly.....	30
2.21	Driveshaft Assembly	31
3	Limited Warranty	32

1 INTRODUCTION

This manual contains parts diagrams and replacement parts lists. Do not modify the equipment in any way. Unauthorized modification may impair the function and/or safety and could affect the life of the equipment.

It is the responsibility of the owner to make sure the machine is maintained properly, and that all parts are in working order.

Where replacement parts are necessary for periodic maintenance and servicing, genuine factory replacement parts ***MUST*** be used to restore your equipment to original specifications. The manufacturer will not be responsible for injuries or damages caused by use of unapproved parts and/or accessories.

The manufacturer reserves the right to make improvements to the machinery and parts at any time and at their discretion.

OPERATOR ORIENTATION - The directions left, right, front and rear, are as seen from the driver's seat and facing in the direction of travel.

1.1 PURCHASER'S RESPONSIBILITY

It is the responsibility of the purchaser and/or operator to.....

- Inspect the equipment and replace or repair any parts that are damaged or worn which under continued operation would cause damage, wear to other parts, or cause a safety hazard.
- Return the equipment or parts to the authorized dealer, from where it was purchased, for service or replacement of defective parts that are covered by warranty. (The factory may inspect equipment or parts before warranty claims are honored.)
- Payment of all costs incurred by the dealer for travelling to or transporting the equipment for warranty inspection and or claims.

1.2 MODEL / SERIAL NUMBER

NAME: _____

PURCHASED FROM: _____

DATE OF PURCHASE: _____

MODEL NUMBER: P45N1-400-G15

SERIAL NUMBER: 130328

2 REPLACEMENT PARTS

2.1 FRAME ASSEMBLY

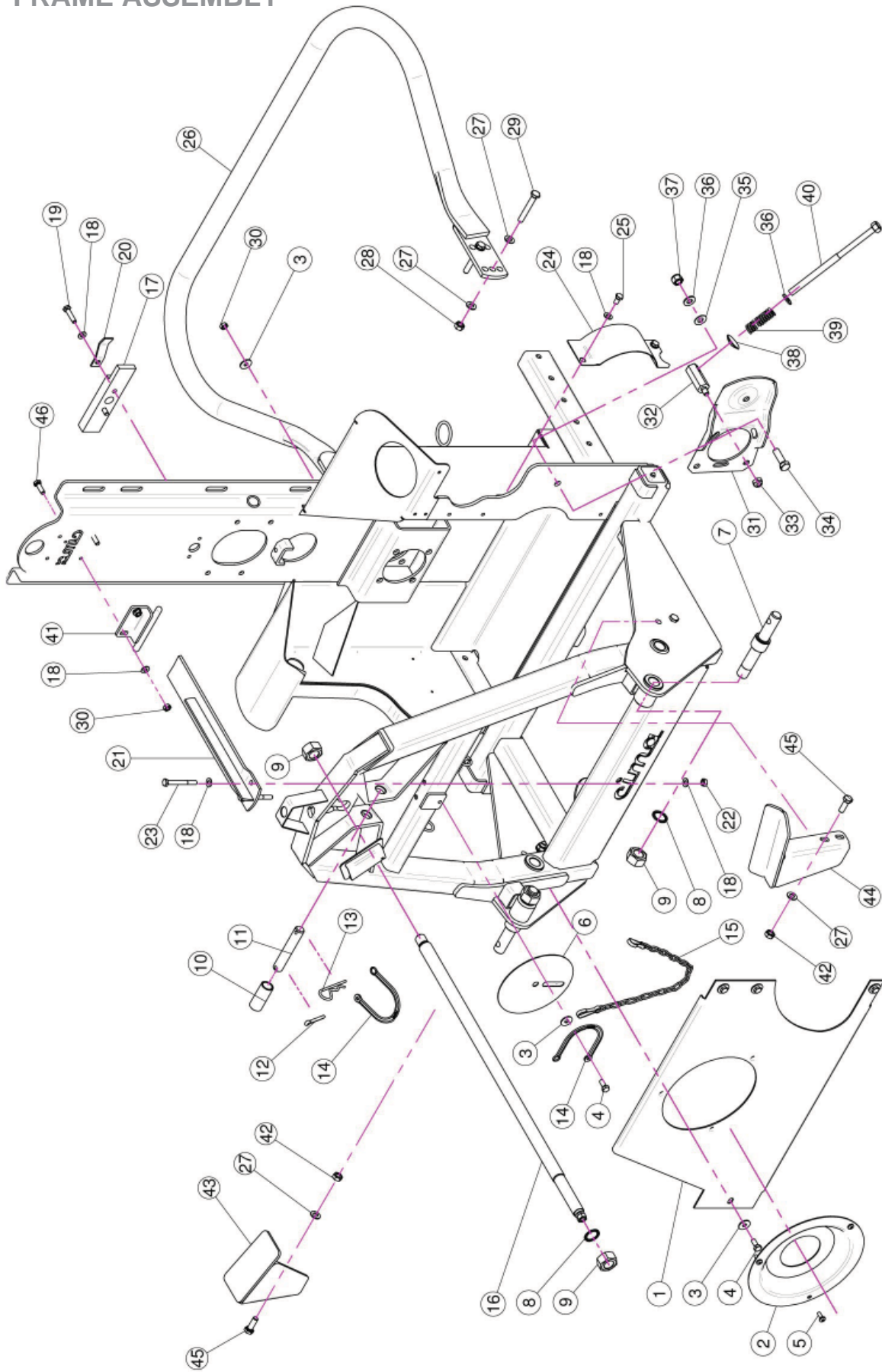

2.1 FRAME ASSEMBLY

<u>REF.</u>	<u>QTY.</u>	<u>PART NO.</u>	<u>DESCRIPTION</u>
1	1	40.227.002	Protection Plate
2	1	20.434.000	Fixing Cover
3	6	RP.008.024	Washer D.8 x 24
4	2	TE.008.020T	Screw TE 8 x 20
5	3	TCC.06.16	Cross Slotted Screw M6 x 16
6	1	20.861.000	Disengaged Protection Disk
7	2	04.064.001	Pin Power Lift
8	3	RD.022.000	Tab Washer D.22
9	4	D0.22.5588F	Nut M22 x 1.5
10	1	20.778.000	Bush
11	1	04.076.000	Pin
12	1	CP.006.040I	Pin D.6 Lg.40
13	1	00.100.004	Split Pin D.4
14	2	21.183.000	Cap Stop
15	1	04.111.045	Chain
16	1	20.754.101	Tie Rod
17	1	20.737.101	Plate For Rod M20
18	10	RP.008.000	Washer D.8
19	2	TE.008.035T	Screw TE M8 x 35
20	1	20.791.000	Plate
21	1	20.744.000	Fixing Tank Plate
22	2	D0.08.5588G	M8 6S Big Lead Nut 5588
23	2	TE.008.070	Screw TE M8 x 70
24	1	20.743.000	Save Pulley Plate
25	5	TE.008.016T	Screw TE M8 x 16
26	1	40.000.000	Bumper
27	12	RP.010.000	Washer D.10
28	4	D0.10.5587G	Nut M10
29	4	TE.010.070T	Screw TE 10 x 70
30	3	D0.08.5588G	Nut M8
31	1	02.978.000SX	Bracket
32	1	02.963.100	Pin Belt Stretcher Pump CD32
33	1	DA.010.0BG	Self Locking Nut M10
34	1	TE.012.040T	Bolt TE M12 x 40
35	1	MT.012.000	Washer D.12
36	2	RP.012.000	Washer D.12
37	1	DA.012.0AG	Nut M12
38	1	21.113.000	Washer D.12 x 36
39	1	02.964.000	CD 32 Pump Spring
40	1	20.738.000	Lever M12 For Belt Stretcher
41	1	40.403.000	Tank Block
42	4	D0.10.5588G	M10 6S Big Lead Nut 5588
43	1	50.395.100	Tank 400 Lt. Right Support
44	1	50.396.100	Tank 400 Lt. Left Support
45	4	TE.010.030T	Screw TE M10 x 30
46	2	TE.008.025T	Screw TE M8 x 25

2.2 TANK & FITTINGS

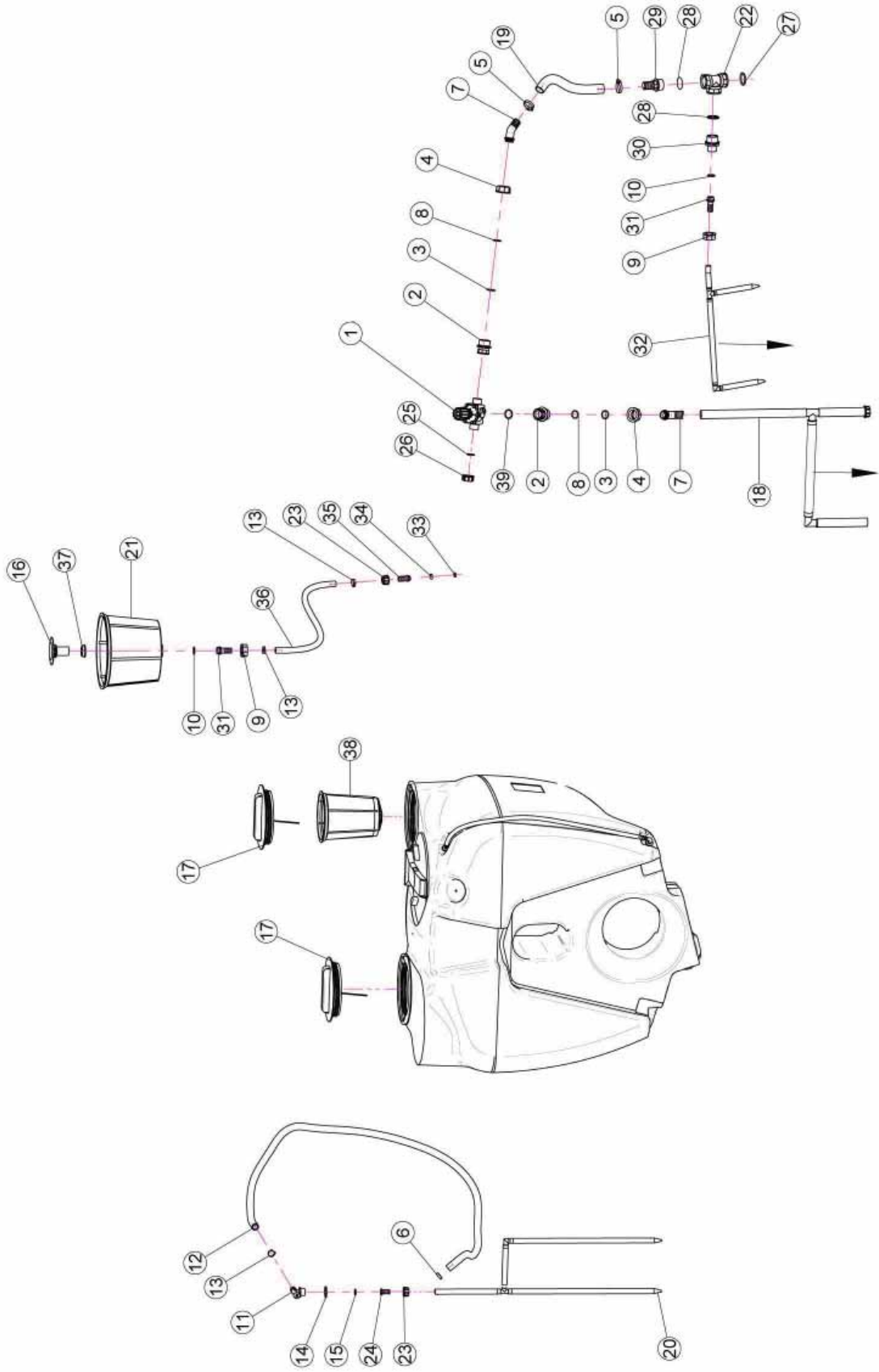

2.2 TANK & FITTINGS

<u>REF.</u>	<u>QTY.</u>	<u>PART NO.</u>	<u>DESCRIPTION</u>
1	1	02.447.300	Three Way Regulation Valve
2	2	02.374.000	M/F 1" F / 1" 1/4M Reduction
3	2	OR.003.112	O-Ring D.28.24 x 2.62
4	2	00.493.000	1" 1/4 Fly Nut
5	2	F0.025.040I	Stainless Steel Cup
6	1	FC.022.5.024	Hose Clamp 22.5 - 24
7	2	02.339.000	45° Hosetail
8	2	OR.003.106	O-Ring D.26.65 x 2.62
9	2	00.055.24.2	1" Fly Nut
10	2	OR.000.132	23.81 x 2.62 O-Ring Gasket
11	1	02.135.100	Complete Short Piston Valve
12	1	02.372.000	Hose D.19 L=1800 (Per Foot)
13	3	FC.023.5.025	Hose Clamp 23.5 - 25
14	1	02.032.000	Gasket D.26 x 40 SP.2
15	1	02.349.000	17 x 23 x 3 Flat Gasket
16	1	00.131.000	1" Vortix Damper Drive
17	2	02.476.100	Threaded Lid D.255 With Rope
18	1	21.394.100	Mixing Pipes From Regulation Valve
19	1	02.238.000	Hose D.30 L=440 (Per Foot)
20	1	21.380.400	Pneumatic Agitator
21	1	00.646.010	Basket Filter D.302 x 254
22	1	24.075.000	1 1/4" Female T Threaded Union
23	2	00.055.045	3/4" Fly Nut
24	1	21.392.000	Hosetail D.16
25	1	24.100.000	Gasket D.30 x 3
26	1	TF.001.000	Packing
27	1	OR.006.162	O-Ring Gasket 40 x 5
28	2	OR.000.144	O-Ring D.39.69 x 3.53
29	1	00.423.000	Male Connector RH30 1" 1/4 GAS
30	1	00.045.012	1" 1/4M - 1"M Reducer Nipple
31	2	00.055.022	Straight Hose R.H. D.19
32	1	21.393.000	Mixing Hose From Pump
33	1	OR.000.117	13.1 x 18.34 x 2.62 O-Ring Gasket
34	1	OR.000.121	15.88 x 2.62 O-Ring Gasket
35	1	21.184.000	Straight Union 3/4" R.H. 20
36	1	02.372.000	Hose D.19 L=600 (Per Foot)
37	1	00.542.000	Nut 1"
38	1	02.298.000	Basket Filter D.204
39	1	OR.004.118	29.75 x 3.53 O-Ring Gasket

2.3 HAND CLEANING TANK & COVERS

20.787.000

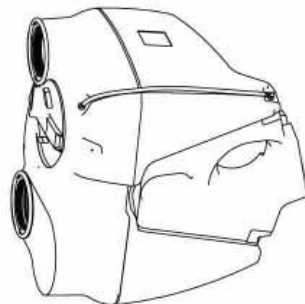
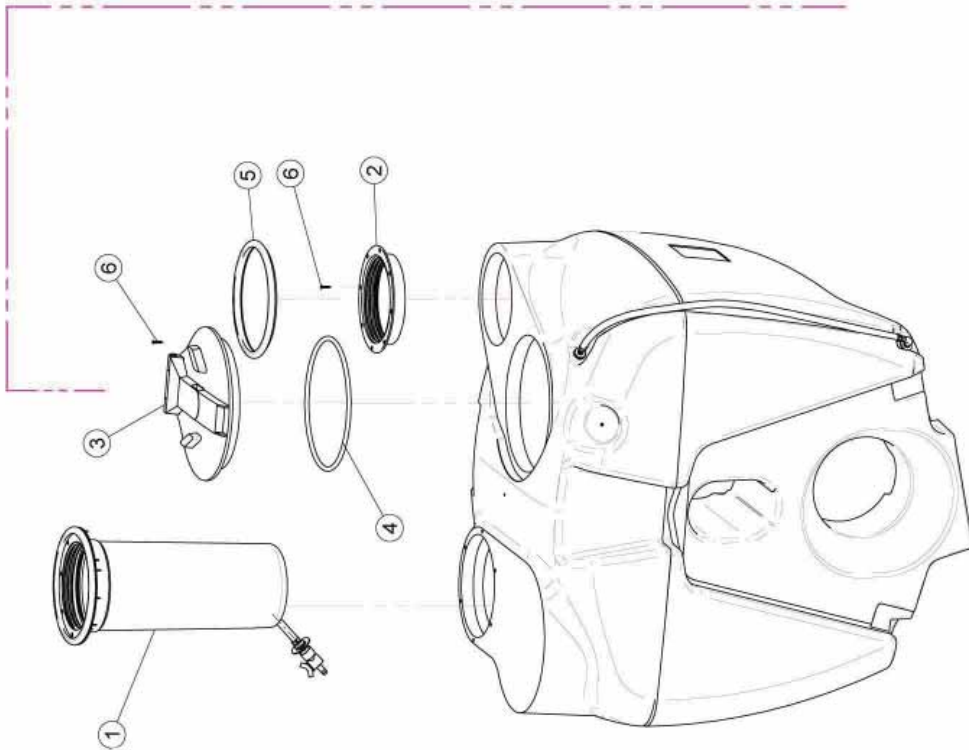
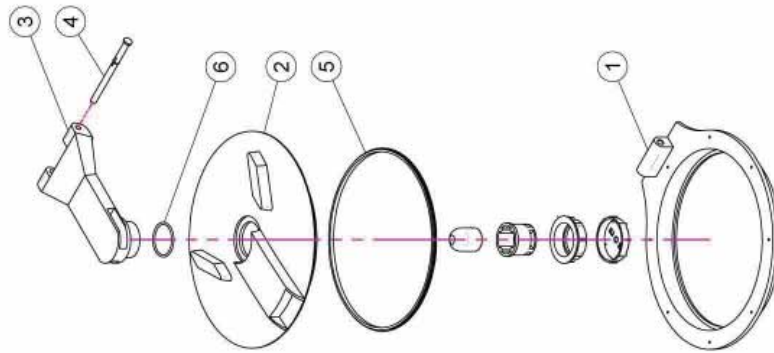

2.3 HAND CLEANING TANK & COVERS

50.352.000

<u>REF.</u>	<u>QTY.</u>	<u>PART NO.</u>	<u>DESCRIPTION</u>
1	1	LAV.04.P15	Kit Hand Cleaner Tank
2	1	02.477.000	Threaded Ring D.255
3	1	20.787.000	Hinged Tank Lid
4	1	20.787.000.L	Gasket
5	1	02.477.000.A	Threaded Ring Gasket D.255
6	16	TAS.04.2.025I	Self Threaded Screw 4.2 x 25

20.787.000

<u>REF.</u>	<u>QTY.</u>	<u>PART NO.</u>	<u>DESCRIPTION</u>
1	1	20.787.000.B	Base Ring
2	1	20.787.000.A	Gripping Plate
3	1	20.787.000.C	Arm
4	1	20.787.000.D	Pin
5	1	20.787.000.E	Shaped Gasket
6	1	OR.000.512	51 x 3.5 O-Ring Gasket
7	1	20.787.000.F	Floating Ball
8	1	20.787.000.G	Breather Valve
9	1	20.787.000.H	Ring Nut
10	1	20.787.000.I	Cap For Breather Valve

2.4 TANK FITTINGS

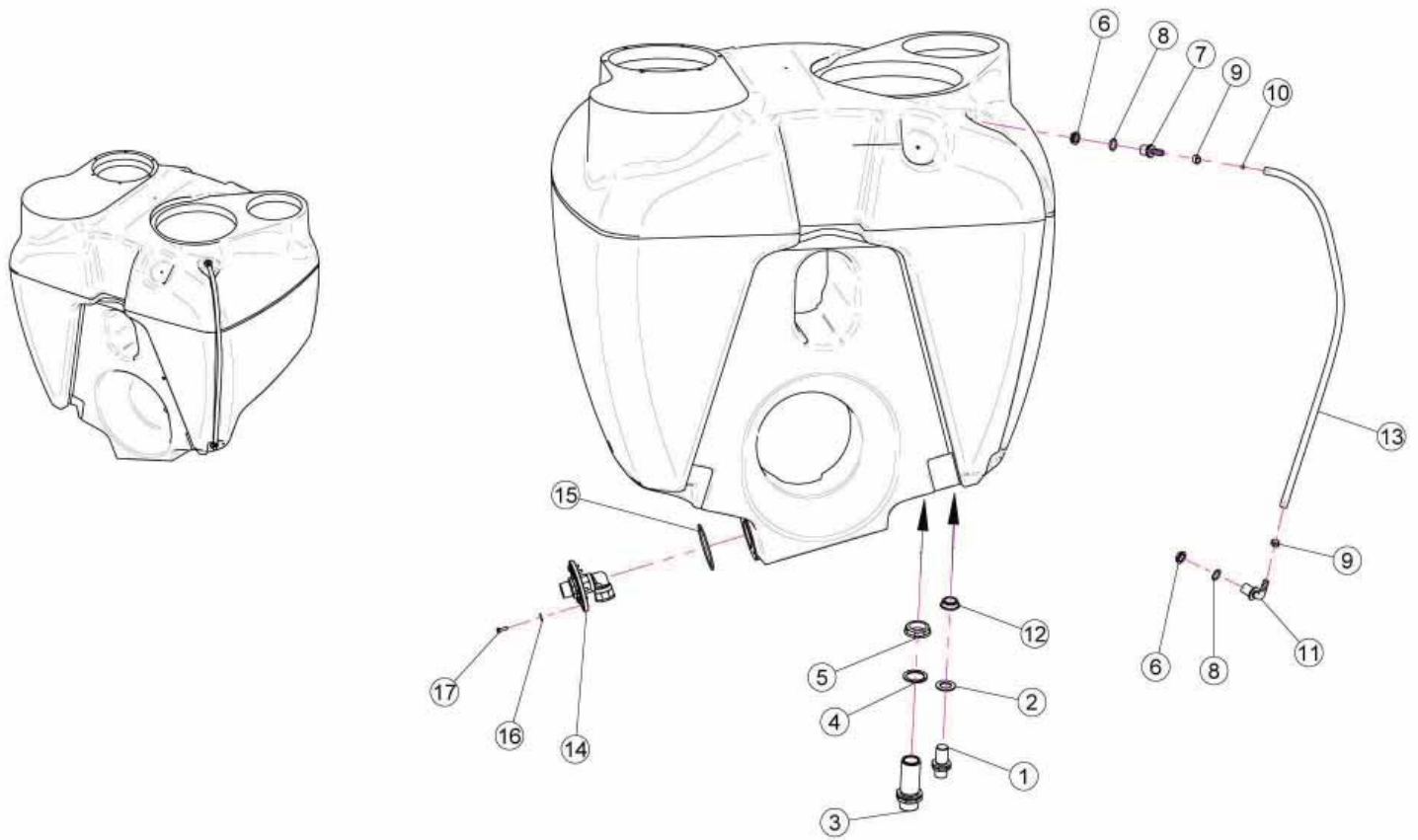

<u>REF.</u>	<u>QTY.</u>	<u>PART NO.</u>	<u>DESCRIPTION</u>
1	1	02.380.100	Nipple 3/4"
2	1	02.032.000	Gasket D.26 x 40 Sp.2
3	1	00.345.000	Nipple 1" 1/4 + 1" 1/4 GAS
4	1	02.033.000	Gasket
5	1	00.543.000	Nut 1" 1/4 GAS
6	2	02.458.000	Lock Ring 1/2"
7	1	02.482.000	Hosetail Male Threaded 1/2"
8	2	OR.004.081	20.22 x 3.53 O-Ring Gasket
9	2	FC.016.5.018	Hose Clamp 16.5 - 18
10	1	02.478.000	Red Floating Ball D.8.5
11	1	02.457.000	Hosetail D.13 90° M. 1/2"
12	1	00.541.000	Nut 3/4"
13	1	02.378.000	Hose D.12 x 16 L=850 (Per Foot)
14	1	40.399.000	Complete Vortex Damper
15	1	OR.004.400	O-Ring D.101.2 x 3.53
16	6	RP.006.018	Washer D.6 x 18
17	6	TE.006.020T	Screw TE M6 x 20

2.5 HAND CLEANING TANK & FITTINGS

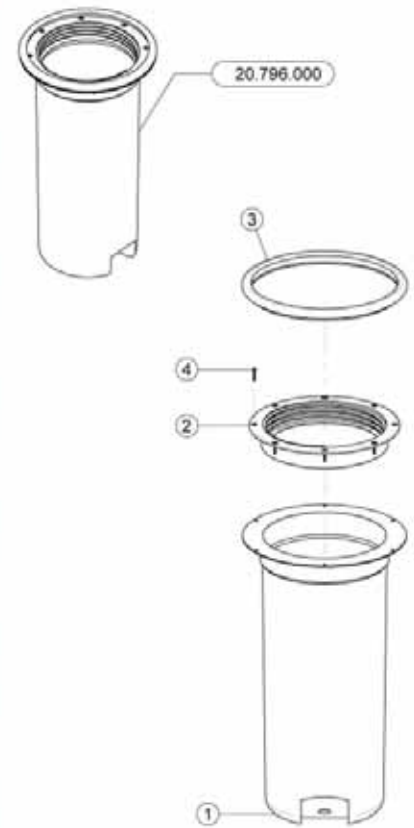
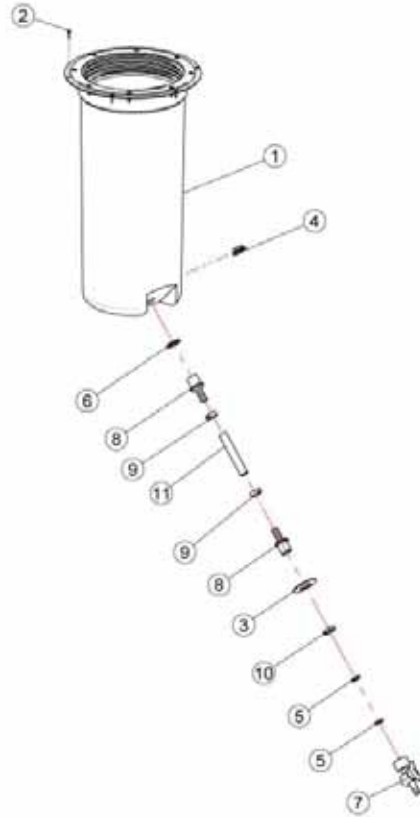

K.LAV.04.P15

<u>REF.</u>	<u>QTY.</u>	<u>PART NO.</u>	<u>DESCRIPTION</u>
1	1	20.796.000	Hand Washing Tank Complete
2	6	TA.03.9.016I	Self Threaded D.3.9 x 16
3	1	20.801.000	Special Washer D.25.5/52
4	1	02.458.000	Lock Ring 1/2"
5	2	20.769.000	Gasket D.19.2/11.5 x 2.5
6	1	02.265.000	Plane Gasket D.20/30 x 2.5
7	1	20.797.000	Mini Valve G 1/2" F.
8	2	02.482.000	Hosetail Male Threaded 1/2"
9	2	FC.016.5.018	Hose Clamp 16.5 - 18
10	1	24.072.000	Brass Fly Nut 1/2"
11	1	02.220.000	Hose D.13 L=100 (Per Foot)

20.796.000

<u>REF.</u>	<u>QTY.</u>	<u>PART NO.</u>	<u>DESCRIPTION</u>
1	1	20.796.000	Hand Washing Tank Lt. 15
2	1	02.477.000	Threaded Ring D.255
3	1	02.477.000.A	Threaded Ring Gasket D.255
4	8	RV.4.0.020	Rivet D.4 x 20

2.6 FAN ASSEMBLY

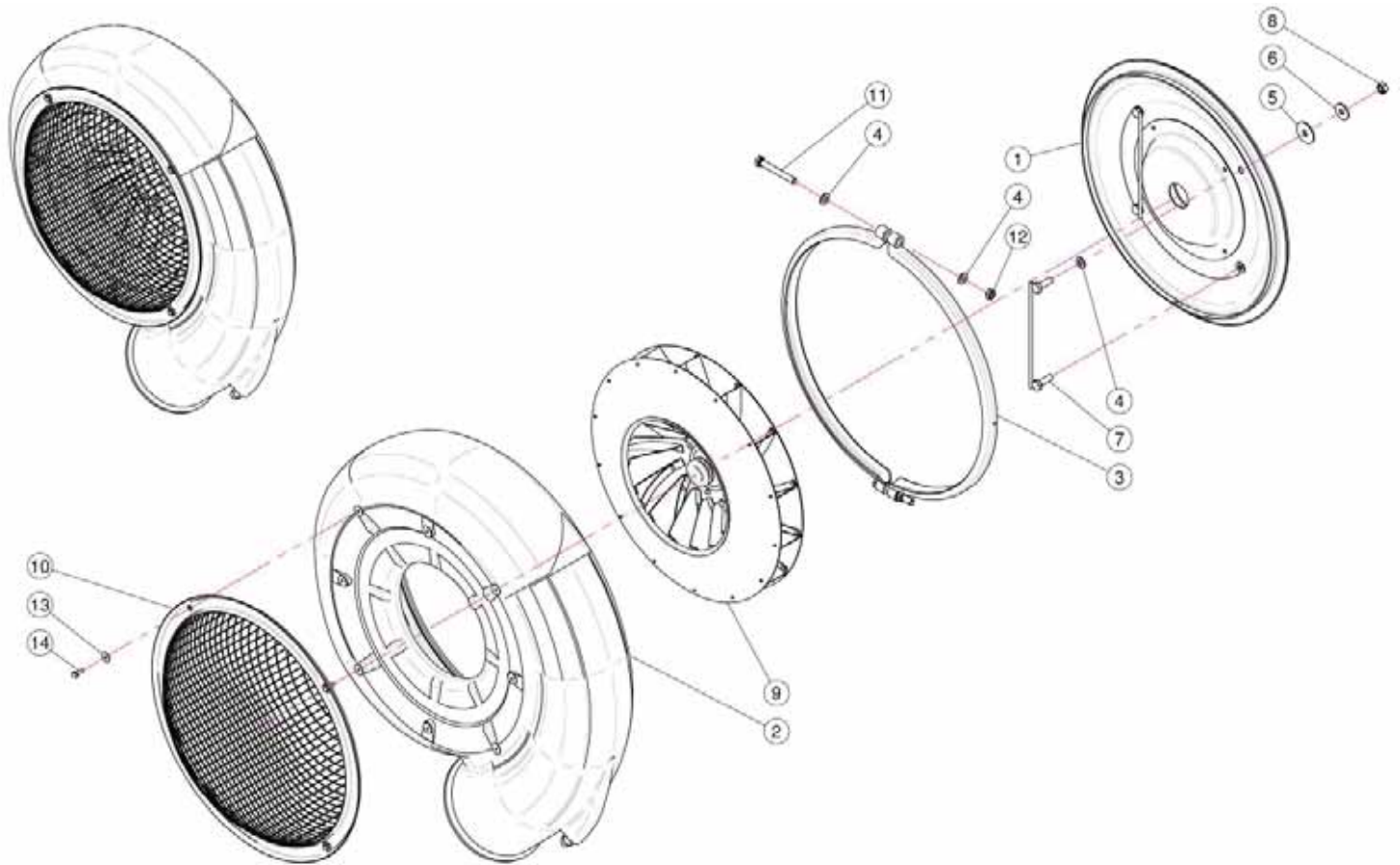

<u>REF.</u>	<u>QTY.</u>	<u>PART NO.</u>	<u>DESCRIPTION</u>
1	1	40.268.000	Fan 45 Cover
2	1	04.854.000	45 Fan Housing
3	1	04.874.000.Z	D.485 Clamp
4	8	RP.010.000	Washer D.10
5	4	RP.010.040	Washer D.10 x 40
6	4	RP.010.030	Washer D.10 x 30 mm
7	2	20.088.000	Back Cover Bracket
8	4	D0.10.5587G	Nut M10
9	1	04.720.000	Fan 450
10	1	05.654.200	Fan Net Protector
11	2	TE.010.080T	M10 x 80 Bolt
12	2	DOT.10.5587	M10 Brass Nut
13	4	RP.006.018	Washer D.6 x 18
14	4	TE.006.016T	Screw TE M6 x 16

2.7 FAN SUPPORT & BELT TENSIONER

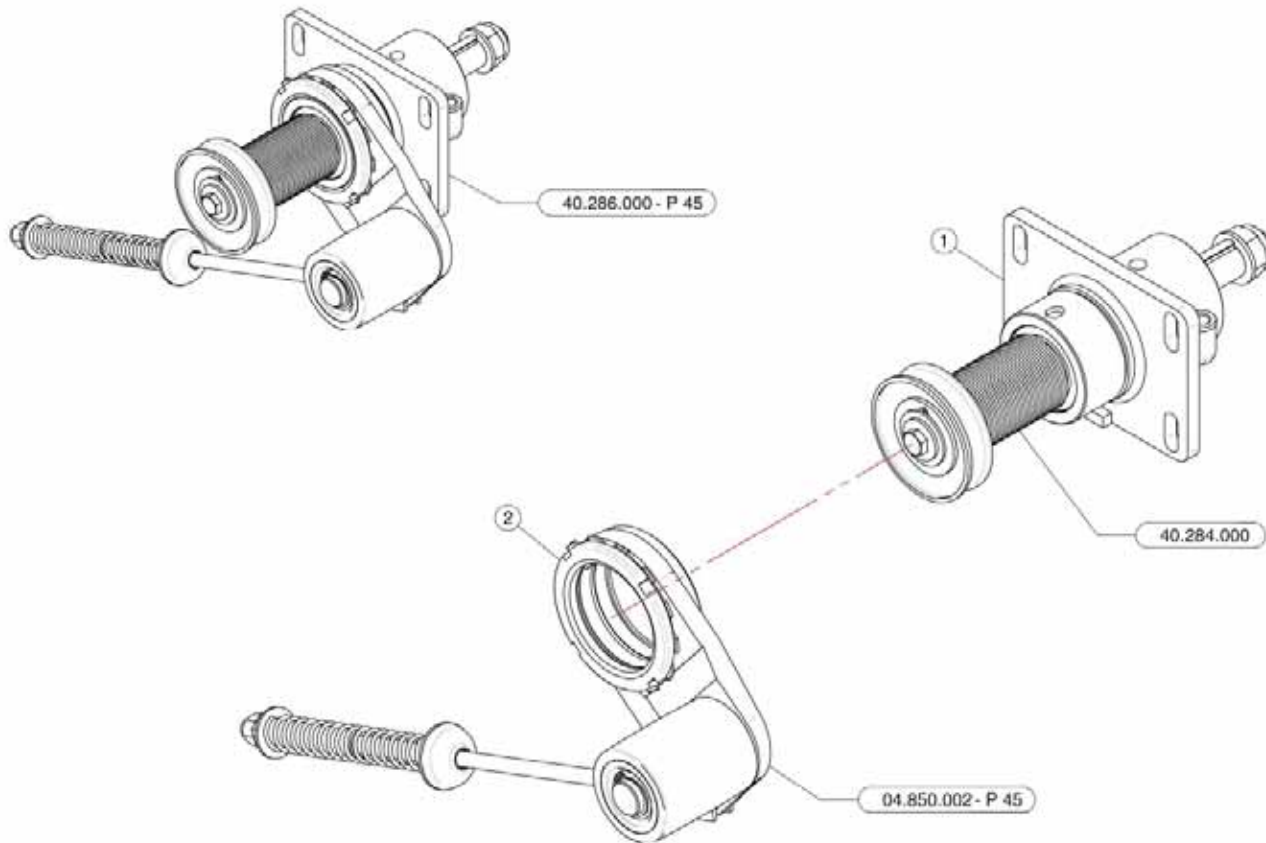

40.286.000

<u>REF.</u>	<u>QTY.</u>	<u>PART NO.</u>	<u>DESCRIPTION</u>
1	1	40.284.000	Fan Support - Pul D.54 No Disengagement
2	1	04.850.002	Automatic Belt Stretcher

40.287.000

<u>REF.</u>	<u>QTY.</u>	<u>PART NO.</u>	<u>DESCRIPTION</u>
1	1	40.284.000	Fan Support - Pul D.54 No Disengagement
2	1	04.850.000	Automatic Belt Stretcher

2.8 FAN SUPPORT BREAKDOWN

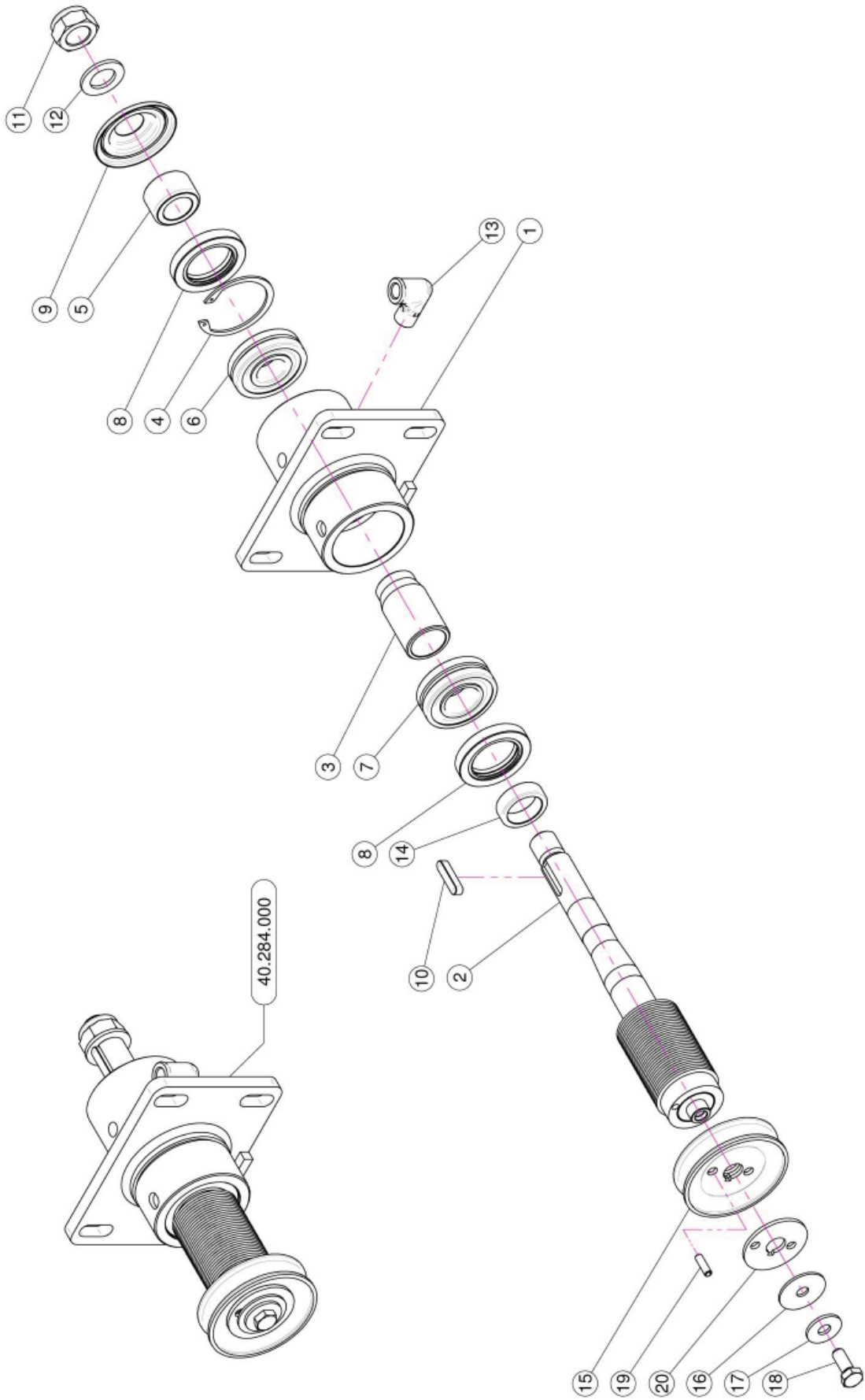

2.8 FAN SUPPORT BREAKDOWN

<u>REF.</u>	<u>QTY.</u>	<u>PART NO.</u>	<u>DESCRIPTION</u>
1	1	40.260.000	Fan Support
2	1	40.271.054	Shaft With Pulley D.54 J32
3	1	40.262.000	Spacer Fan Support
4	1	I0.062.000	Internal D.62 Circlip
5	1	40.263.000	Side Fan Seal Spacer
6	1	K0.021.305	Bearing To Oblique Seams 21.305
7	1	K0.022.206	Bearing To Oblique Seams 22.206
8	2	BASL.40.62.10	Viton Lip Seals IEL 40.62.10
9	1	40.267.000	Side Fan Cover
10	1	L.08.07.35	8 x 7 x 35 Tang
11	1	DA.022.0BF	Self Locking Nut M22 x 1.5
12	1	RP.022.000	Washer D.22
13	1	20.789.000	Male/Female 90° Elbow
14	1	40.264.000	Spacer
15	1	02.723.003	Pulley For Pump D.78 x 1.3V
16	1	RP.010.040	Washer D.10 x 40
17	1	RP.010.030	Washer D.10 x 30 mm
18	1	TE.010.025FT	Bolt TE M10 x 25
19	1	SE.006.020	Spring Pin D.6 x 20
20	1	02.723.001	Special Washer mm 3

2.9 TENSION ROLLER

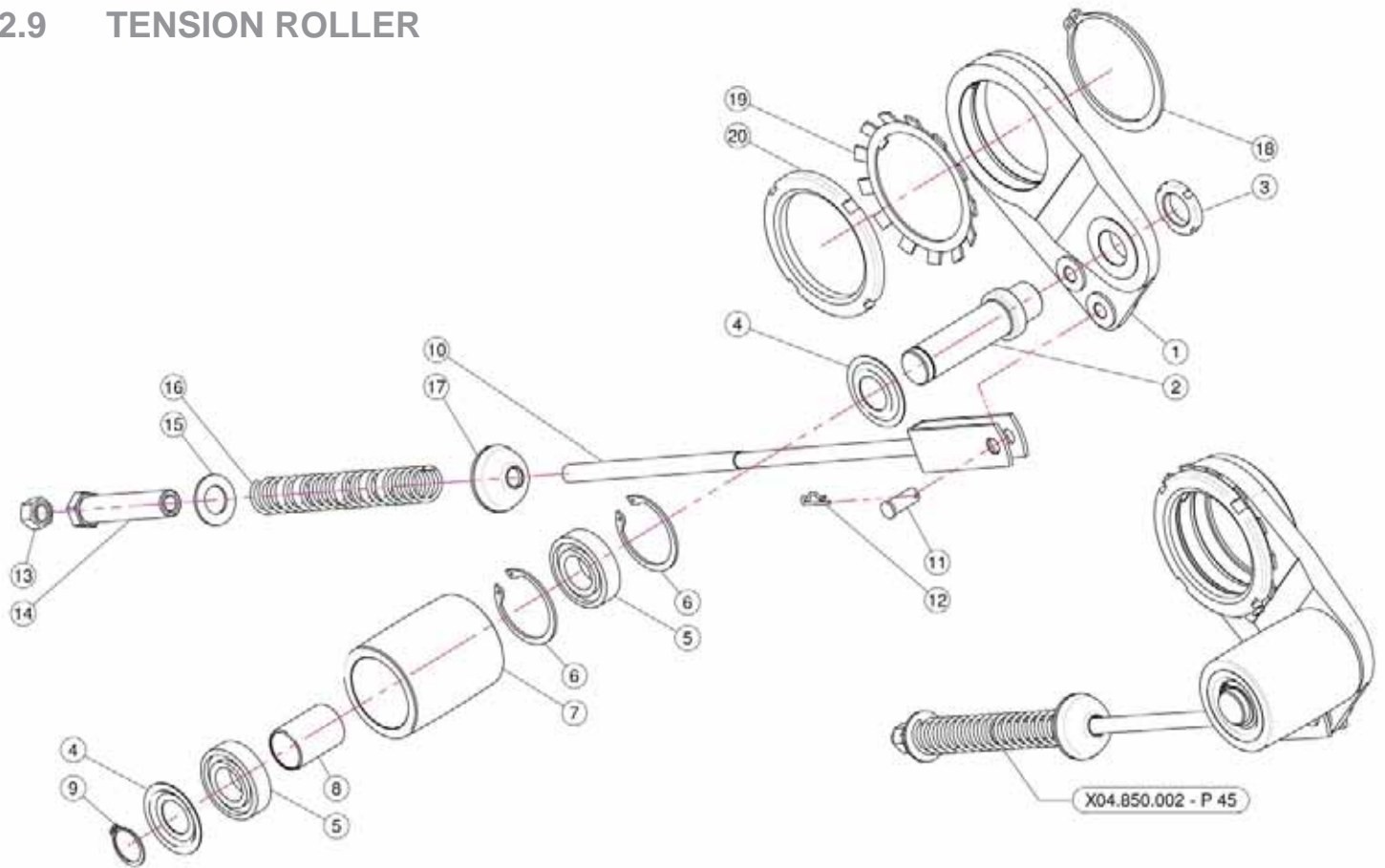

<u>REF.</u>	<u>QTY.</u>	<u>PART NO.</u>	<u>DESCRIPTION</u>
1	1	04.095.000	Belt Stretcher Housing
2	1	04.835.000	Belt Stretcher Pin
3	1	KM.005.000	Nut KM5
4	2	04.585.000	Anti-Dust Cover
5	2	K6.205.2RS	Roller Bearing 6205-2RS
6	2	I0.052.000	Internal D.52 Circlip
7	1	04.083.000	Roller For Belt Stretcher
8	1	04.084.000	Spacer For Belt Stretcher
9	1	E0.025.000	External D.25 Circlip
10	1	05.653.000	Belt Stretcher Fork
11	1	04.593.000	Pin
12	1	00.100.002	Clip
13	1	D0.12.5587G	M12 Nut
14	1	04.583.000	Special Screw
15	1	RP.019.000	Washer D.19
16	1	04.093.100	Spring
17	1	20.260.000	Special Washer D.12
18	1	E0.080.000	External D.80 Circlip
19	1	MB.016.000	Tooth Lock Washer MB 16
20	1	04.099.000	Nut M 80 x 2

2.10 LUBRICATION TUBES

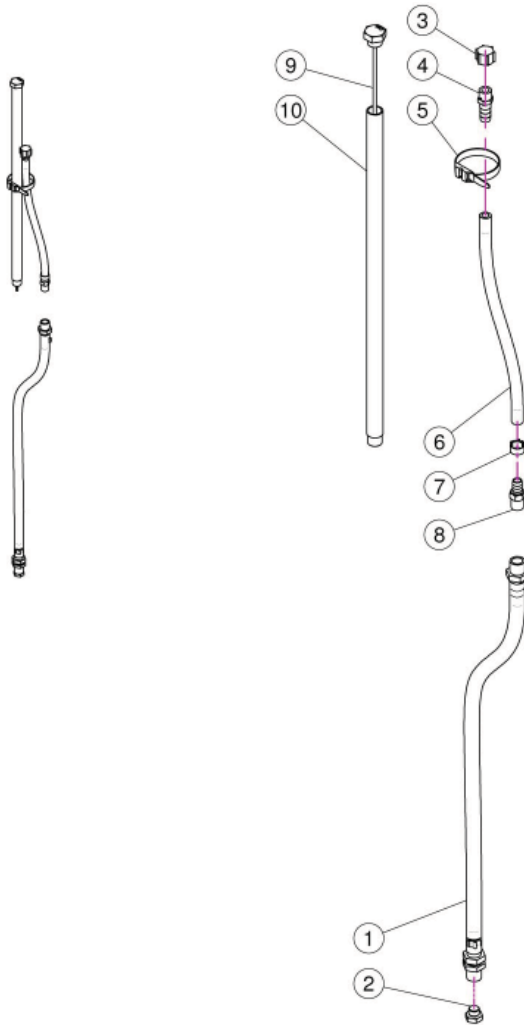

<u>REF.</u>	<u>QTY.</u>	<u>PART NO.</u>	<u>DESCRIPTION</u>
1	1	20.790.000	Drain Pipe 3/8"
2	1	40.266.000	Oil Exhaust Plug
3	1	02.013.000	Plug G1/4"
4	1	00.414.100	Straight Hose D.11 1/4" With Bleed
5	1	02.355.000	Nylon Assembly Clamp
6	1	02.217.000	Hose D.8 x 13 L=250 (Per Foot)
7	1	FC.014.5.016	Hose Clamp
8	1	20.792.000	Straight Hose D.11 G 1/4" For Breather
9	1	50.116.000	Filling Plug With Dipstick
10	1	50.122.000	Filling Pipe L=451

2.11 CLUTCH & PULLEY

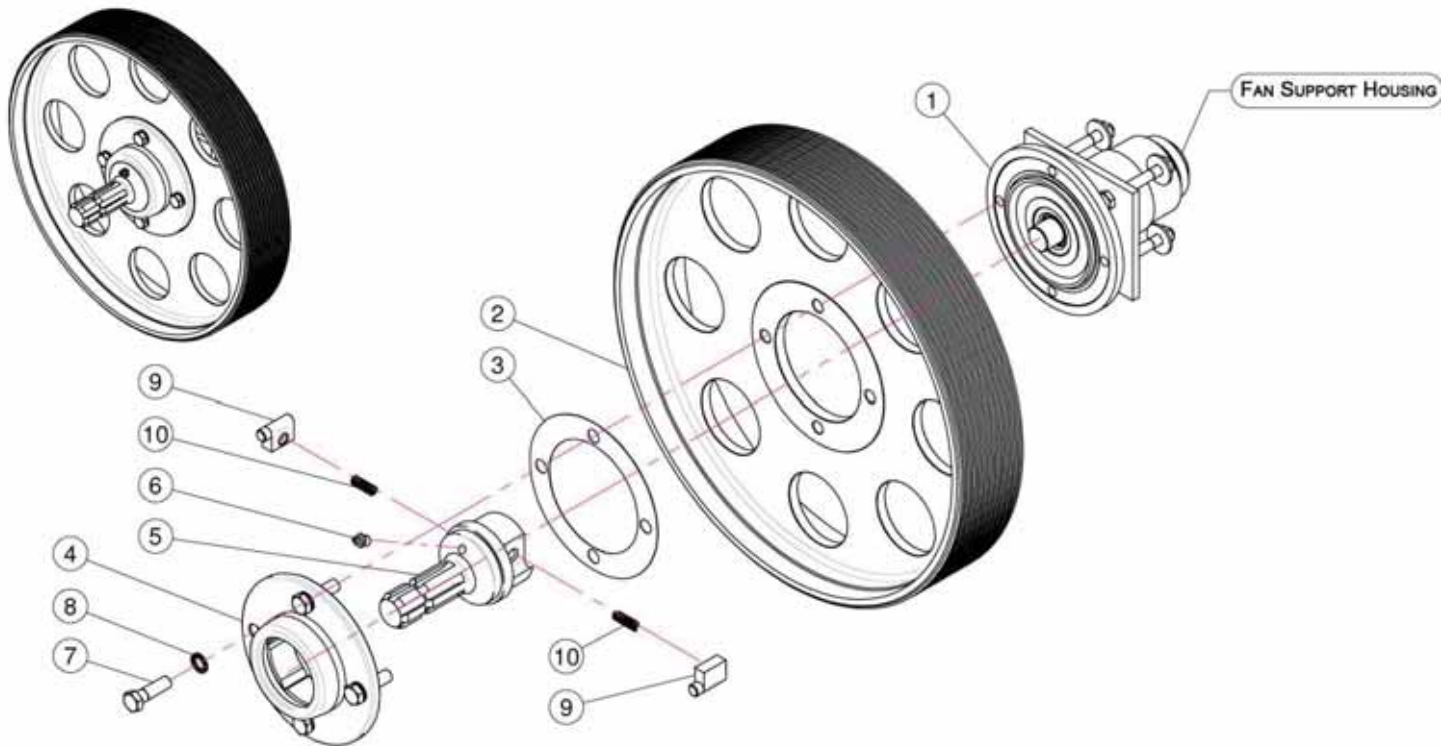

<u>REF.</u>	<u>QTY.</u>	<u>PART NO.</u>	<u>DESCRIPTION</u>
1	1	04.094.01C	Clutch
2	1	00.450.J32	Pulley
3	1	04.719.000	Gasket
4	1	04.066.000	Body
5	1	03.701.000	Rotor
6	1	ID.010.001	Grease Nipple
7	4	TE.012.040F	Bolt M12 x 40
8	4	RD.012.000	Tab Washer D.12
9	2	02.502.002	Pin
10	2	02.502.001	Spring

2.12 FAN SUPPORT HOUSING

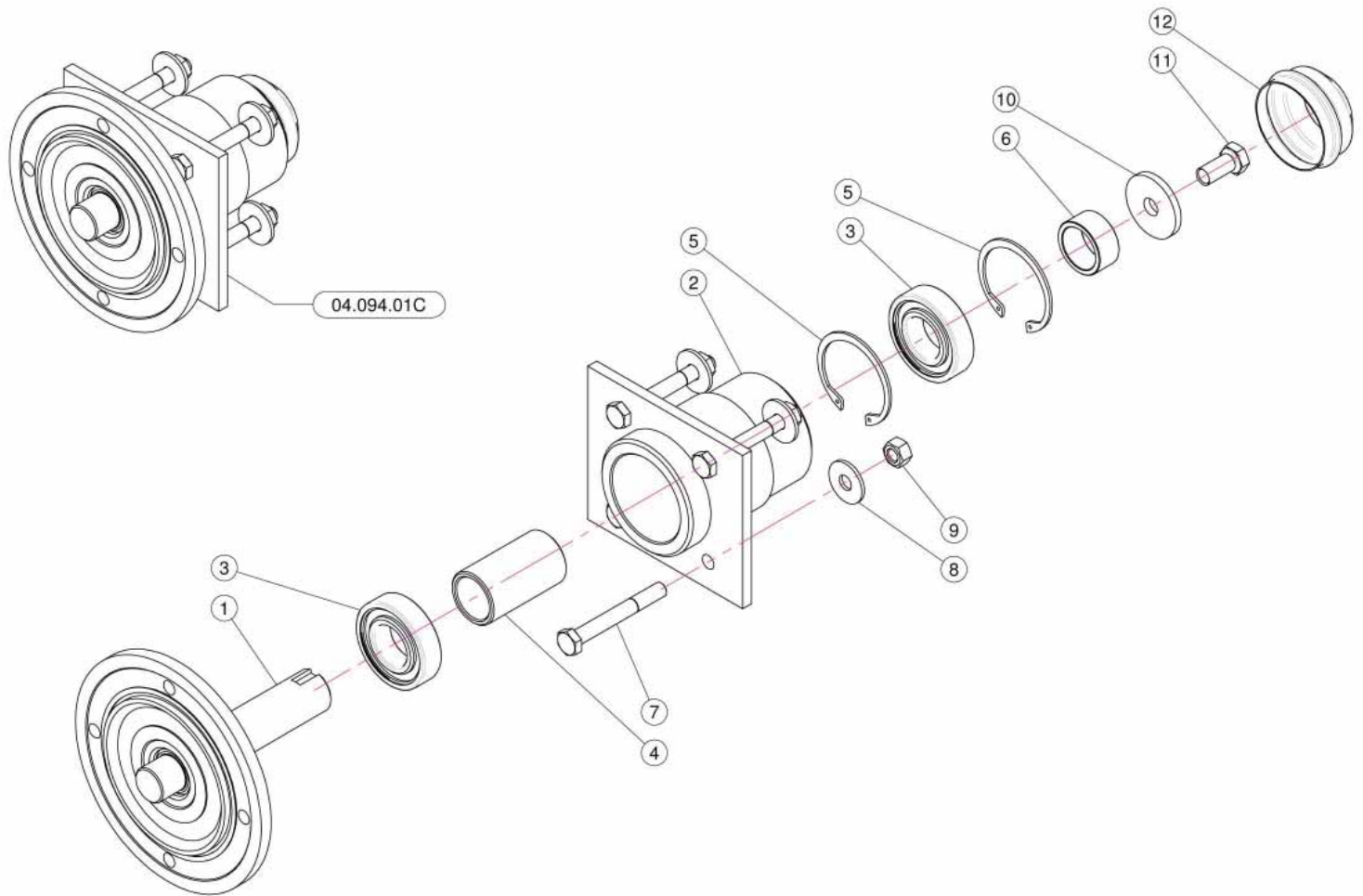

<u>REF.</u>	<u>QTY.</u>	<u>PART NO.</u>	<u>DESCRIPTION</u>
1	1	04.085.000	Shaft
2	1	04.094.000	Clutch
3	2	K6.206.2RS	Bearing
4	1	04.060.000	Spacer
5	2	I0.062.000	Internal D.62 Circlip
6	1	04.590.000	Spacer
7	4	TE.010.080	Screw TE M10 x 80
8	4	RP.010.030	Washer D.10 x 30 mm
9	4	D0.10.5587G	Nut M10
10	1	20.810.000	Special Washer For Lower Support
11	1	TE.012.025FT	Bolt TE M12 x 1.25
12	1	04.062.001	Cover

2.13 LIQUID FLOW PATH

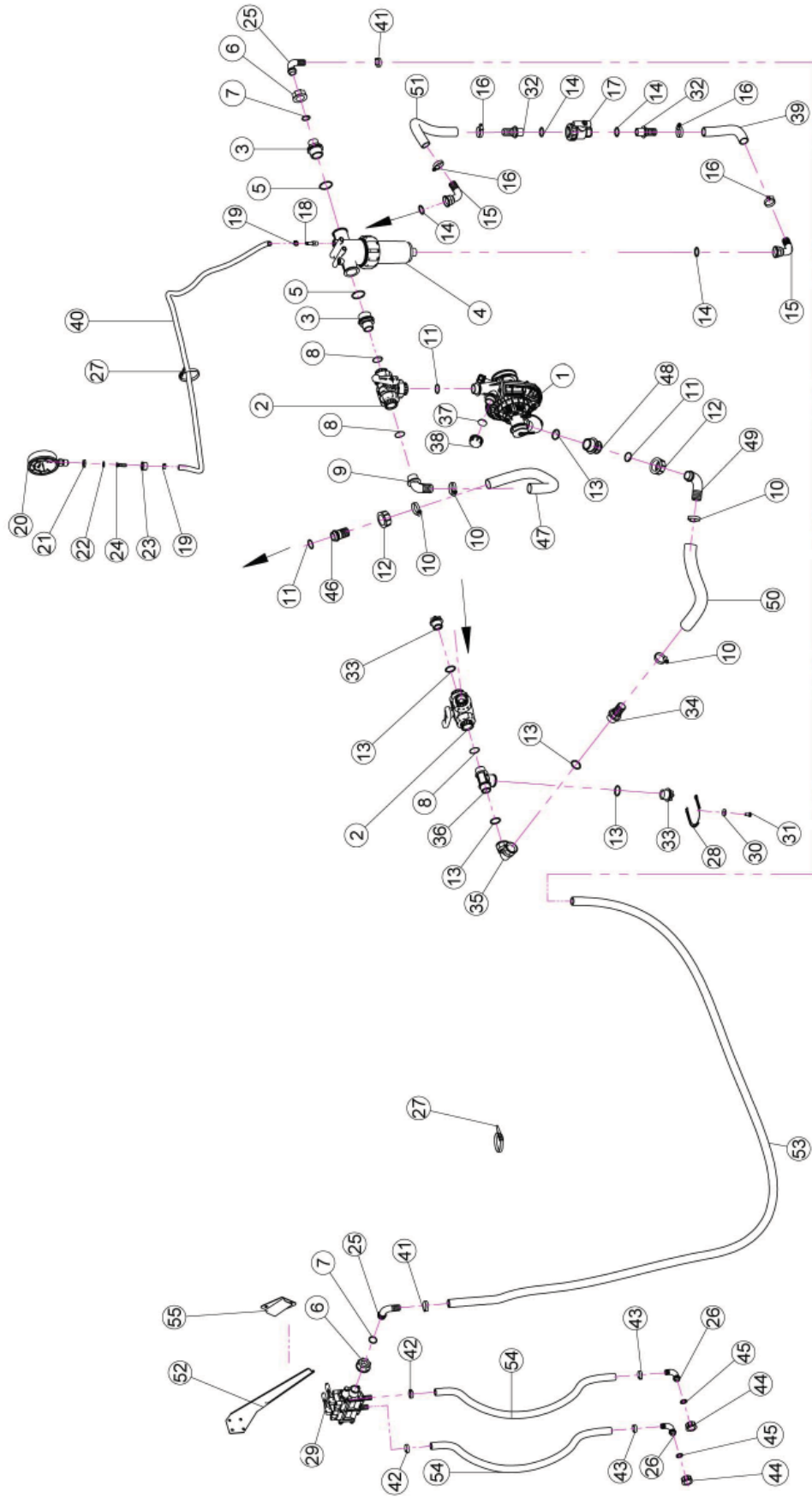

2.13 LIQUID FLOW PATH

<u>REF.</u>	<u>QTY.</u>	<u>PART NO.</u>	<u>DESCRIPTION</u>
1	1	02.157.068	Pump
2	2	21.058.100	Three Way Valve
3	2	00.045.012	1" 1/4 M-1" M Reducer Nipple
4	1	02.450.110	Line Filter 1" 1/4 Female
5	2	OR.000.144	O-Ring D.39.69 x 3.53
6	2	00.055.24.2	1" Fly Nut
7	2	OR.000.132	23.81 x 2.62 O-Ring Gasket
8	3	OR.002.125	31.47 x 1.78 O-Ring Gasket
9	1	00.465.000	Hosetail D.30 1" GAS
10	4	F0.025.040I	Stainless Steel Clip
11	3	OR.003.112	O-Ring D.28.24 x 2.62
12	2	00.058.006	1" 1/4 Fly Nut
13	6	OR.004.118	29.75 x 3.53 O-Ring Gasket
14	4	OR.000.134	O-Ring D.25.8 x 3.53
15	2	20.794.000	Pipe 90° R.H. 25 3/4" GAS F
16	4	F0.023.035I	Stainless Steel Clip
17	1	02.395.000	Valve 3/4" GAS F.F. Ball
18	1	21.084.000	Hosetail 90° WES 8/R1/4
19	2	FC.013.5.015	Hose Clamp
20	1	02.445.000	Pressure Gauge Ø100 INOX 0-6 Bar
21	1	24.072.000	Brass Fly Nut 1/2"
22	1	20.769.000	Gasket D.19.2/11.5 x 2.5
23	1	02.287.000	Fly Nut 1/2"
24	1	02.379.020	Straight Union R.H. 10
25	2	00.055.038	Curved Union With R.H. D.19
26	2	00.055.046	Curved Union With R.H. D.17
27	6	02.355.000	Nylon Assembly clamp
28	1	21.183.000	Cap Stop
29	1	20.108.101C	2 Way Manual Control Group
30	1	RP.008.024	Washer D.8 x 24
31	1	TE.008.016T	Screw TE M8 x 16
32	2	20.793.000	Hosetail R.H. D.25 3/4" GAS M
33	2	21.182.000	Packing 1" M
34	1	00.422.000	Male Connector R.H. 30 1" GAS
35	1	02.291.000	Female Hosetail Thread 1"
36	1	24.065.000	T 1" M - M 1" F
37	1	24.100.000	Gasket D.30 x 3
38	1	TF.001.000	Packing
39	1	20.770.000	Hose D.25 L=300 (Per Foot)
40	1	02.217.000	Hose D.8 x 13 L=1350 (Per Foot)

2.13 LIQUID FLOW PATH

<u>REF.</u>	<u>QTY.</u>	<u>PART NO.</u>	<u>DESCRIPTION</u>
41	2	FC.027.5.029	Hose Clamp 27.08 - W8
42	2	FC.021.5.023	Hose Clamp 21.5 - 23
43	2	FC.023.5.025	Hose Clamp 23.5 - 25
44	2	00.055.045	3/4" Fly Nut
45	2	02.349.000	17 x 23 x 3 Flat Gasket
46	1	00.058.028	Straight Hose R.H. D.30
47	1	20.852.000	Hose D.30 L=430 (Per Foot)
48	1	02.374.000	M/F 1" F / 1" 1/4 M Reduction
49	1	00.058.004	D.30 Hosetail
50	1	02.238.000	Hose D.30 L=360 (Per Foot)
51	1	20.770.000	Hose D.25 L=200 (Per Foot)
52	1	20.112.000	Support Control Assembly
53	1	02.212.000	Hose D.19 x 28 L=4000 (Per Foot)
54	2	02.211.000	Hose D.16 L=4500 (Per Foot)
55	1	20.107.000	Female Bayonet Support

2.14 PRESSURE REGULATOR & 3 WAY VALVE

PRESSURE REGULATOR

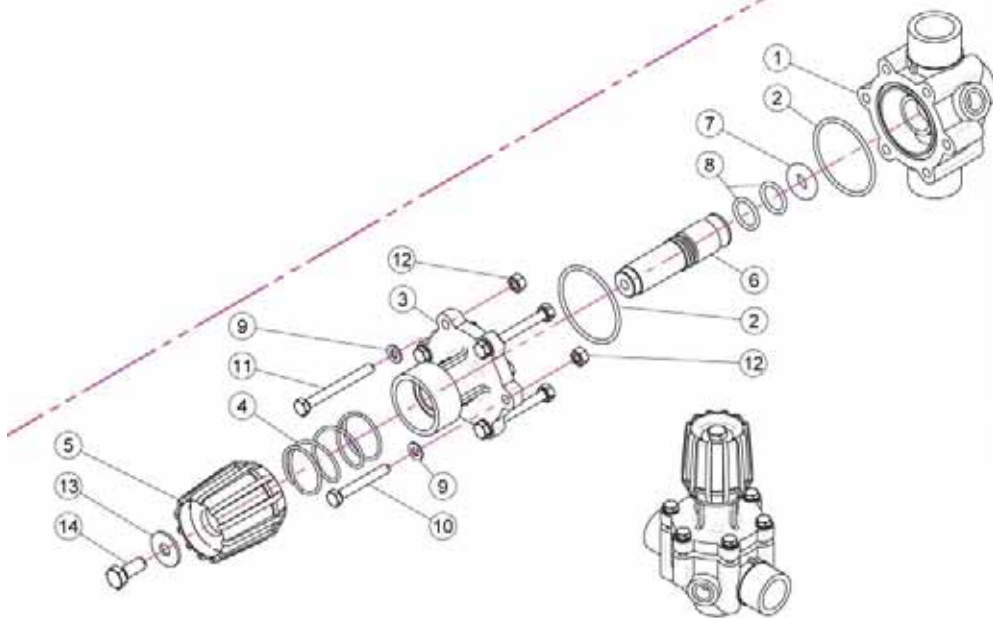

3-WAY VALVE

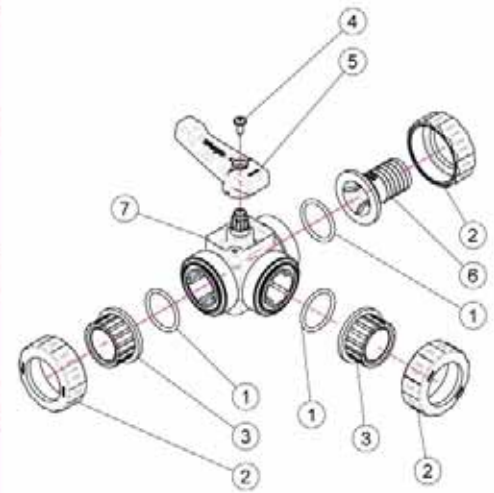

Pressure Regulator

<u>REF.</u>	<u>QTY.</u>	<u>PART NO.</u>	<u>DESCRIPTION</u>
1	1	02.447.001	Body For Regulator Valve
2	2	OR.003.193	O-Ring Gasket 48.89 x 2.62
3	1	02.447.012	Upper Flange
4	1	02.447.011	Spring
5	1	02.447.010	Regulation Valve Knob
6	1	02.447.013	Valve Pin
7	1	02.447.005	Special O-Ring For Gate 2447
8	2	OR.003.068	O-Ring Gasket 17.12 x 2.62
9	6	RP.006.000I	INOX Washer D.6
10	2	TE.006.045I	INOX M6 x 45 Screw
11	4	TE.006.060I	INOX M6 x 60 TE Screw
12	6	D0.06.5588GI	INOX M6 6S Big Lead Nut 5588
13	1	RP.008.024I	INOX Washer D.8 x 24
14	1	TE.008.025I	INOX 8 x 25 Screw

3-Way Valve

1	3	OR.004.137	O-Ring D.34.52 x 3.53
2	3	21.058.007	Valve Union Nut
3	2	21.058.006	Valve End Connector
4	1	TA.05.5.016	Self Threaded Screw M5.5 x 16
5	1	21.058.003	Valve Handle
6	1	21.058.009	Rubber Holder D.30
7	1	21.058.110	Body of Three Way Valve

2.15 INLINE FILTERS

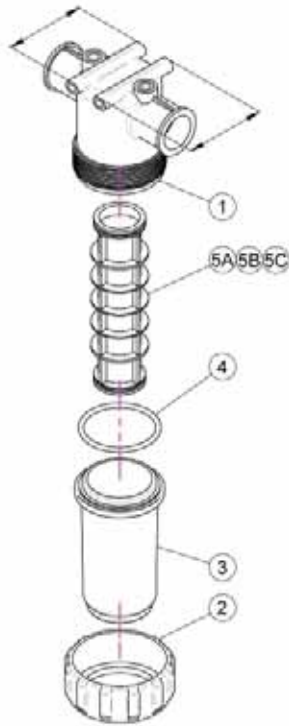

02.450.010

<u>REF.</u>	<u>QTY.</u>	<u>PART NO.</u>	<u>DESCRIPTION</u>
1	1	02.450.101	Line Filter Body
2	1	02.450.003	Ring Nut Filter In Line
3	1	02.450.002	Lid Filter
4	1	OR.000.178	O-Ring D.74.63 x 5.33
5A	1	02.450.004C	Cartridge w/ O-Ring 50 Mesh (Blue)
5B	1	02.450.204C	Cartridge w/ O-Ring 80 Mesh (Grey)
5C	1	02.450.104C	Cartridge w/ O-Ring 32 Mesh (White)

2.16 PUMP ASSEMBLY

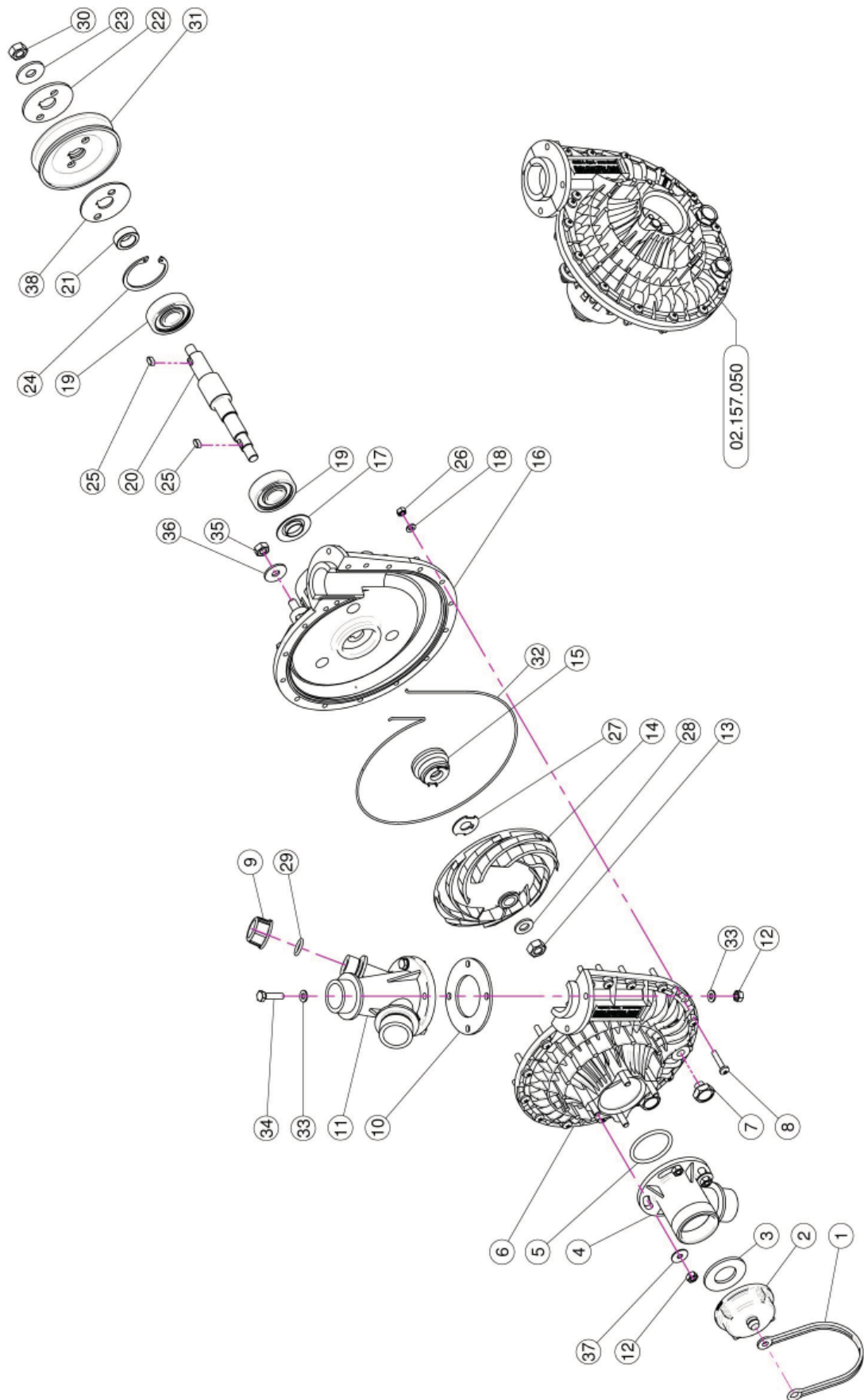

2.16 PUMP ASSEMBLY

<u>REF.</u>	<u>QTY.</u>	<u>PART NO.</u>	<u>DESCRIPTION</u>
1	1	21.183.000	Cap Stop
2	1	02.120.000	Rapid Thread Cap
3	1	02.130.000	24 x 46 x 3 Rubber Gasket
4	1	02.116.000	Suction Fitting
5	1	OR.000.144	O-Ring D.39.69 x 3.53
6	1	02.152.010	Housing
7	2	TM.010.015	M10 x 1.5 Cap
8	17	TC.05.25.85	Cross Slotted Screw M5 x 25
9	1	TF.012.000	Blank Cap 1/2"
10	1	02.179.000	Rubber Gasket
11	1	02.113.000	Delivery Fitting
12	8	DOT.06.5587	M6 Brass Nut 5587
13	1	DOT.10.5587	M10 Brass Nut
14	1	02.153.000	CD32 Pump Impeller
15	1	00.085.024CS	Mechanical Seal
16	1	02.151.010	Pump Casing
17	1	20.406.000	Special Cover For Pump
18	17	RP.005.000	Washer D.5
19	2	K6.303.2RS	Roller Bearing
20	1	02.155.010	CD32 Pump Shaft
21	1	02.722.000	Bush
22	1	02.723.001	Special Washer 3 mm
23	1	RP.010.030	Washer D.10 x 30 mm
24	1	I0.047.000	Internal D.47 Circlip
25	2	L.05.05.10	5 x 5 x 10 Tang
26	17	DOT.05.5587	M5 Brass Nut (5587)
27	1	02.114.000	INOX Special Washer
28	1	RP.010.00I	Washer D.10 INOX
29	1	OR.000.117	13.1 x 18.34 x 2.62 O-Ring Gasket
30	1	D0.10.5588G	M10 6S Big Lead Nut 5588
31	1	02.723.002	Pulley For Pump D.82.5 x 1 3 V
32	1	OR.C02.070	OR Cord D.2 L=700
33	8	RP.006.000	Washer D.6
34	4	TE.006.025T	Screw TE M6 x 25
35	3	D0.08.5588G	M8 6S Big Lead Nut 5588
36	3	RP.008.024	Washer D.8 x 24
37	3	RP.006.018	Washer D.6 x 18
38	1	02.723.005	Special Washer 2 mm

2.17 LIQUID VALVES

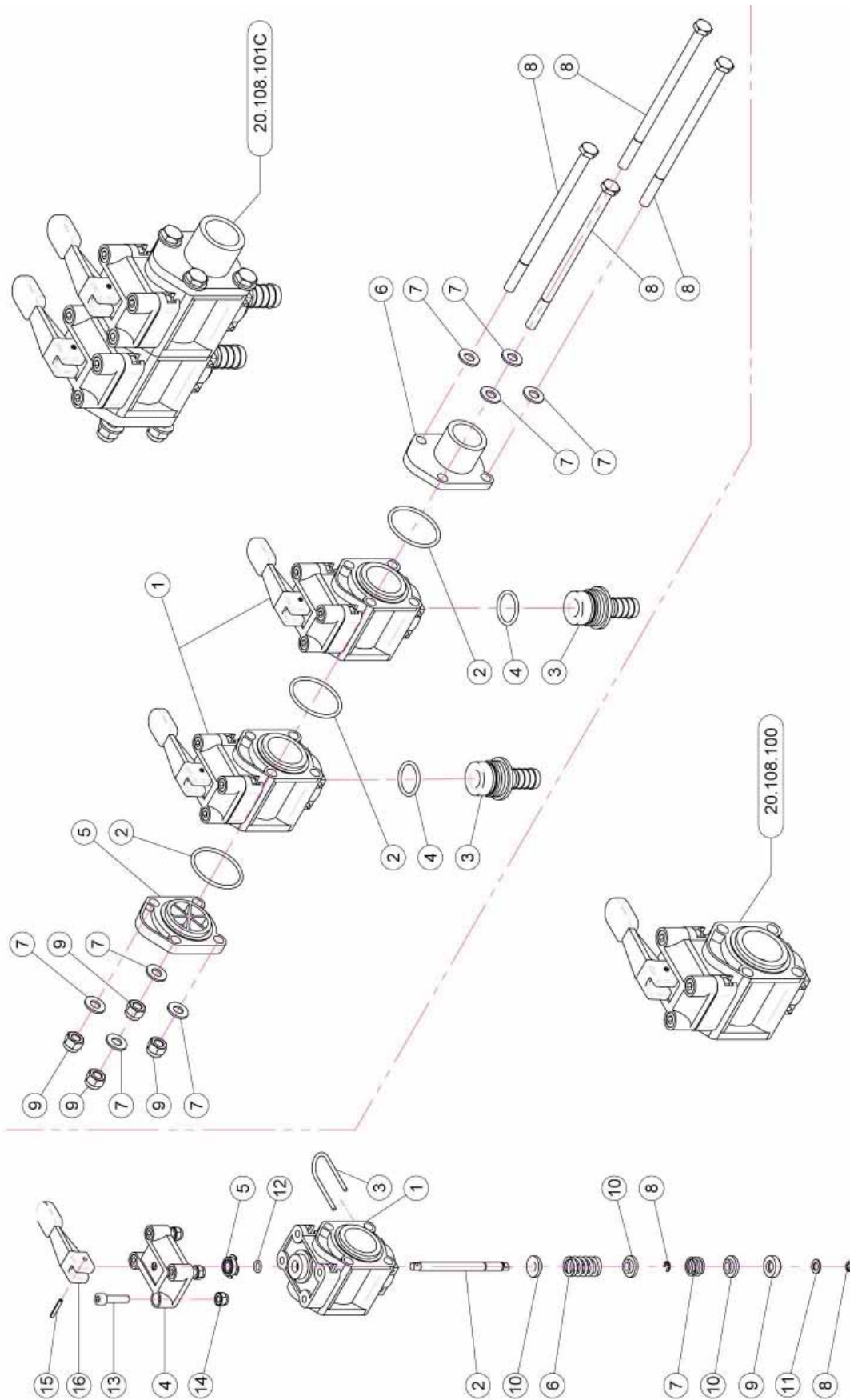

2.17 LIQUID VALVES

20.108.100

<u>REF.</u>	<u>QTY.</u>	<u>PART NO.</u>	<u>DESCRIPTION</u>
1	1	21.069.000	Valve Body
2	1	21.074.000	INOX Manual Valve Pivot
3	1	21.073.000	Fork
4	1	21.070.000	Manual Switch Valve Flange
5	1	21.075.000	Closing
6	1	21.076.000	Reserve Spring
7	1	21.077.000	Reserve Spring
8	2	AR.004.00I	Rings of Stop Expel Them D.4
9	1	02.390.015	Lower Valve
10	3	02.390.009	Superior Valves
11	1	02.390.014	Washer 7.2 x 12 INOX
12	1	02.390.016	O-Ring
13	4	TCE.006.025	Screw M6 x 25
14	4	DA.006.0AG	Self Locking Nut - High M6
15	1	SE.003.020	Spring Pin D.3 L=20
16	1	21.089.000	Lever For Manual Switch

20.108.101C

1	2	20.108.100	Simple Valve Group
2	3	OR.003.156	O-Ring Gasket 39.34 x 2.62
3	2	02.406.000	Hosetail D.16
4	2	OR.000.130	22.22 x 2.62 O-Ring Gasket
5	1	21.071.000	Valve Flange
6	1	21.072.000	Connect Flange 1 "GAS"
7	8	RP.008.000	Washer D.8
8	4	TE.008.150	Screw TE M8 x 150
9	4	DA.008.0AG	Self Locking Nut M8

2.18 LIQUID VALVES - ELECTRO (Optional)

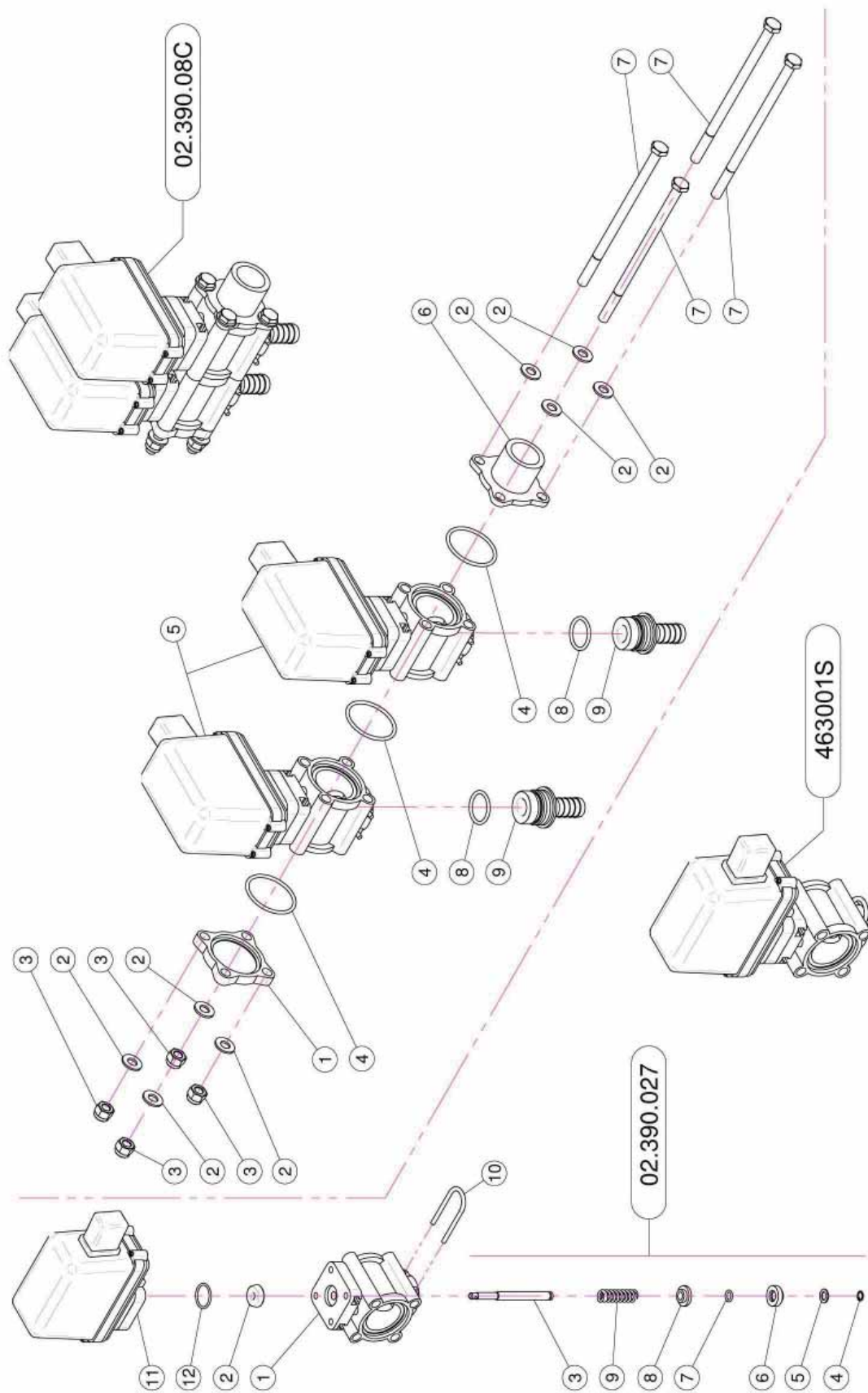

2.18 LIQUID VALVES - ELECTRO (Optional)

02.390.029

<u>REF.</u>	<u>QTY.</u>	<u>PART NO.</u>	<u>DESCRIPTION</u>
1	1	02.390.007	Valve Body
2	1	02.390.008	Gasket
3	1	02.390.020	Pin
4	1	02.390.013	Stop Ring
5	1	02.390.014	Washer 7.2 x 12 INOX
6	1	02.390.015	Lower Valve
7	1	02.390.016	O-Ring
8	1	02.390.009	Superior Valves
9	1	02.390.011	Spring
10	1	21.130.005	Fork
11	1	02.390.028	Solenoid Valve
12	1	OR.002.075	D.18.77 x 1.78 O-Ring

02.390.08C

1	1	02.390.017	Valve Flange
2	8	RP.008.000	Washer D.8
3	4	DA.008.0AG	Self Locking Nut M8
4	3	OR.003.156	O-Ring Gasket 39.34 x 2.62
5	2	02.390.029	Solenoid Valve
6	1	02.390.018	Connector
7	4	TE.008.150	Screw TE M8 x 150
8	2	OR.000.130	22.22 x 2.62 O-Ring Gasket
9	2	02.406.000	Hosetail D.16

2.19 CONTROL SWITCH (Optional)

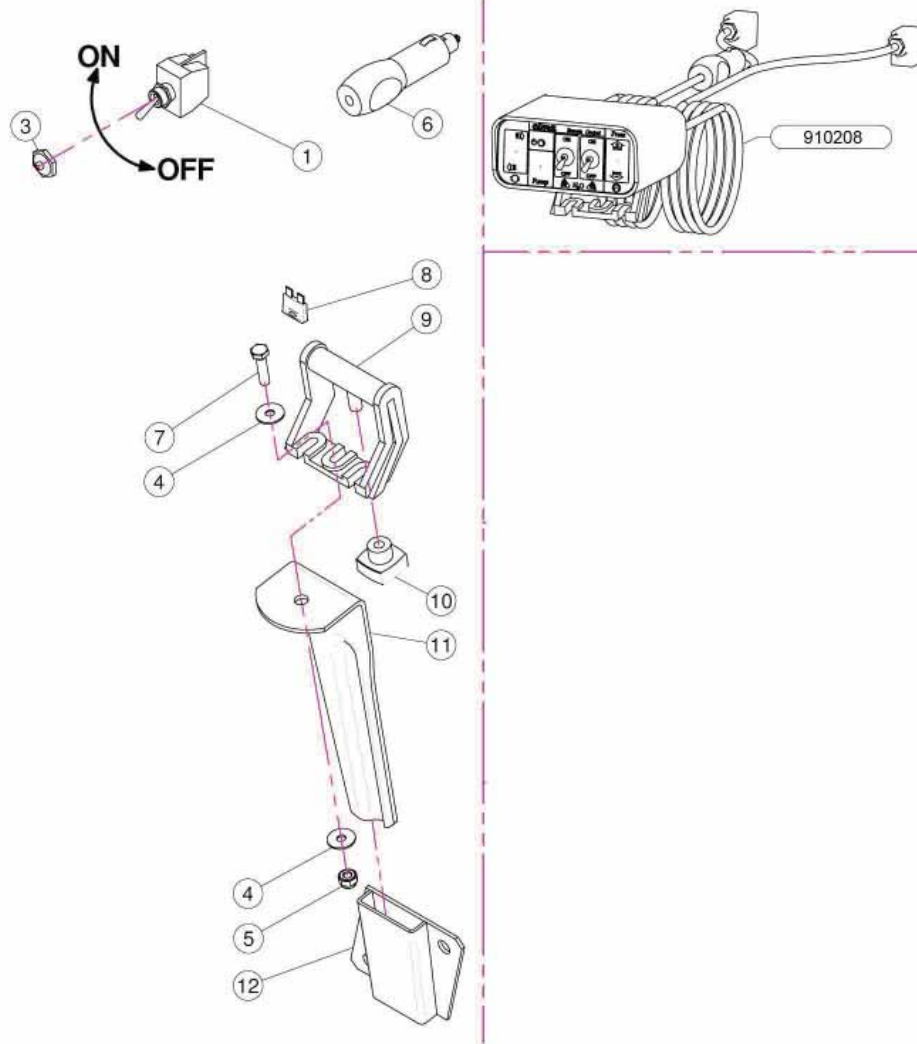

REF.	QTY.	PART NO.	DESCRIPTION
1	2	21.030.005	Switch 2V 2P On-Off 10A
3	2	21.030.007	Switch Cap D.12
4	2	RP.006.018	Washer D.6 x 18
5	1	DA.006.0AG	Self Locking Nut - High M6
6	1	21.030.008	12V Power Jack
7	1	TE.006.025T	Screw TE M6 x 25
8	1	21.030.004	10 Ah Fuse
9	1	21.030.002	Moving Fixing Bracket
10	1	21.030.003	Fixing Knob
11	1	20.111.000	Bracket
12	1	20.107.000	Female Bayonet Support

2.20 DRIVE ASSEMBLY

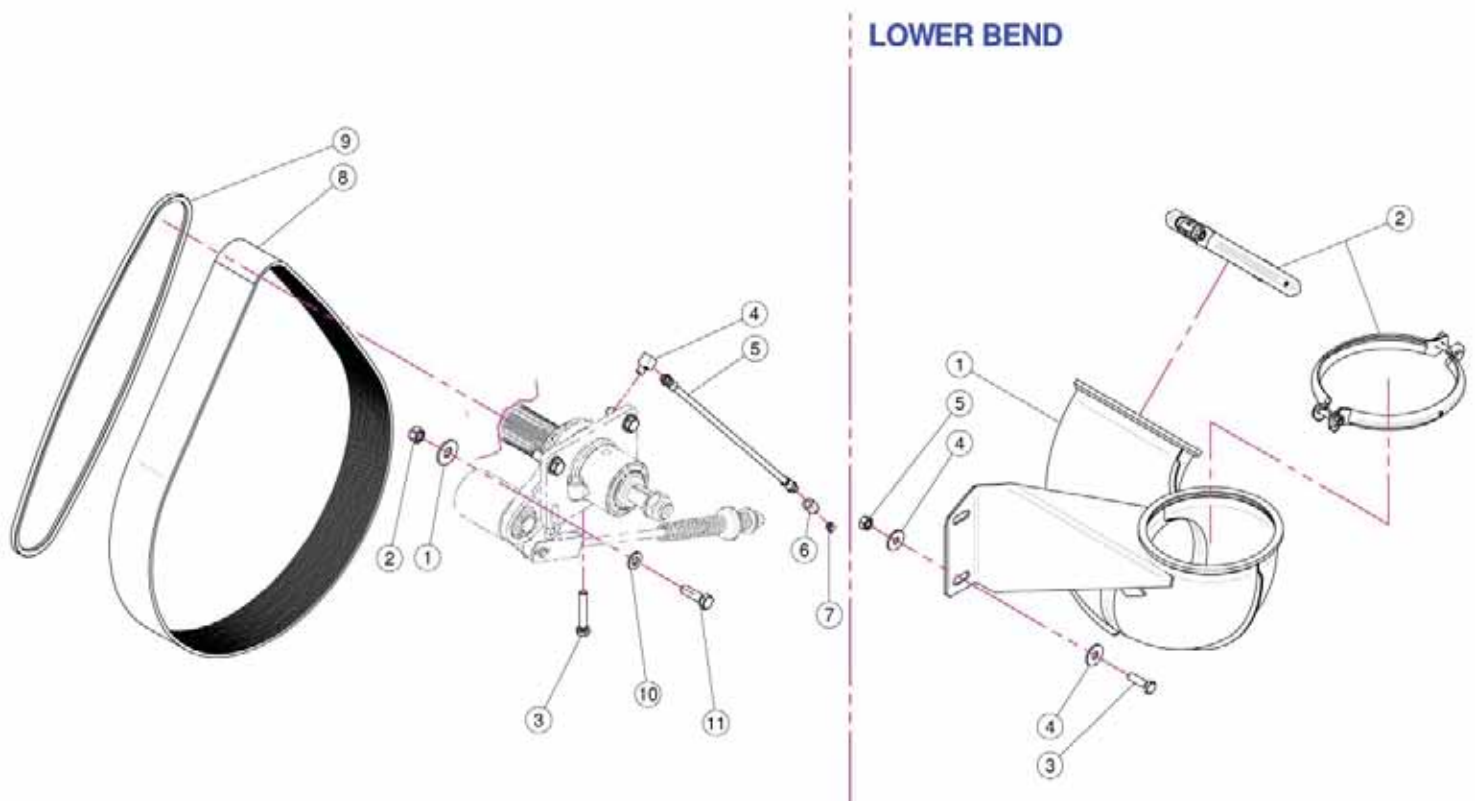

<u>REF.</u>	<u>QTY.</u>	<u>PART NO.</u>	<u>DESCRIPTION</u>
1	4	RP.012.036	Washer D12 x 36
2	4	D0.12.5587G	M12 Nut
3	1	TE.010.060T	Screw TE M10 x 60
4	1	02.736.000	90 G. M10 x 1 Fitting
5	1	02.738.040	Greaser Extension M10 x 1 L=400
6	1	02.737.000	Accessory
7	1	ID.010.001	Grease Nipple
8	1	C0.650.J32	Poly V-Belt
9	1	C0.530.03V	V-Belt
10	4	RP.012.000	Washer D.12
11	4	TE.012.040T	Bolt TE M12 x 40

LOWER BEND

1	1	04.882.000	Lower Bend D.175
2	2	05.616.000	Pipe Clamp D.175
3	2	TE.010.035T	Screw TE 10 x 35
4	4	RP.010.030	Washer D.10 x 30 mm
5	2	D0.10.5587G	Nut M10

2.21 DRIVESHAFT COMPLETE #AB6105

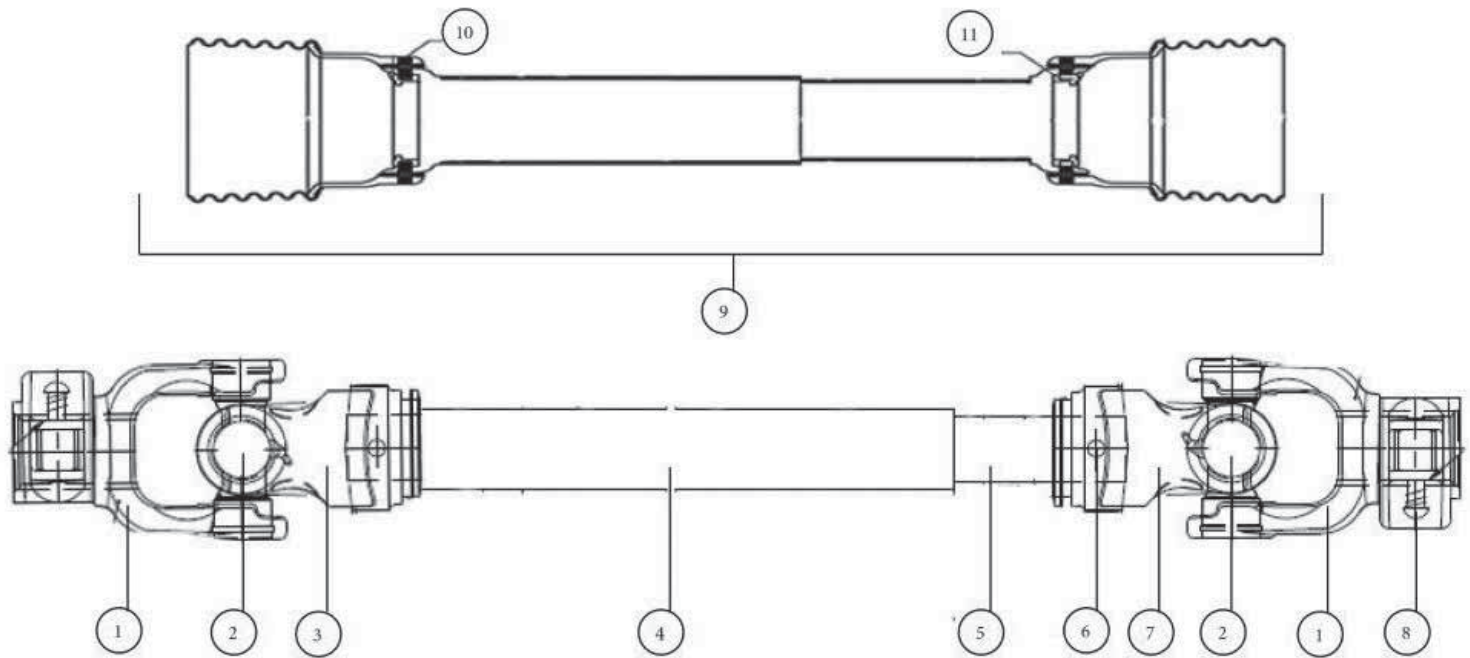

REF.	PART NO.	DESCRIPTION
1	A622138	Quick Release Yoke 1 3/8" x 6 Spline
2	A622	Cross Bearing (2 Required)
3	A6254	Outer Tube Yoke
4	A544	Outer Drive Tube
5	A454	Inner Drive Tube
6	A1065	Poll Pin (2 Required)
7	A6245	Inner Tube Yoke
8	AB121	Quick Release Button
9	AS30090	Safety Guard Complete With Bearing
10	AS301	Release Lever Kit
11	ASB3	Bearing Kit

3 LIMITED WARRANTY



GEARMORE, INC., warrants each new Gearmore product to be free from defects in material and workmanship for a period of twelve (12) months from date of purchase to the original purchaser. This warranty shall not apply to implements or parts that have been subject to misuse, negligence, accident, or that have been altered in any way.

Our obligation shall be limited to repairing or replacement of any part, provided that such part is returned within thirty (30) days from date of failure to Gearmore through the dealer from whom the purchase was made, transportation charges prepaid.

This warranty shall not be interpreted to render us liable for injury or damages of any kind or nature, direct, consequential or contingent, to person or property. This warranty does not extend to loss of crops, loss because of delay in harvesting or any other expenses, for any other reasons.

Gearmore in no way warrants engines, tires, or other trade accessories, since these items are warranted separately by these respective manufacturers.

Gearmore reserves the right to make improvements in design or changes in specification at any time, without incurring any obligations to owners or units previously sold.

Please be advised that all warranty work done by your dealer must be approved by Gearmore before work begins.

GEARMORE, INC.
13477 Benson Ave.
Chino, CA 91710

Always refer to and heed machine operating warning decals on machine.

*To validate the warranty on this product, please log-in to our website - www.gearmore.com.
You will find "warranty registration" listed at the top of our home page.*