

GEARMORE INC.

VENTURI AIR SPRAYERS

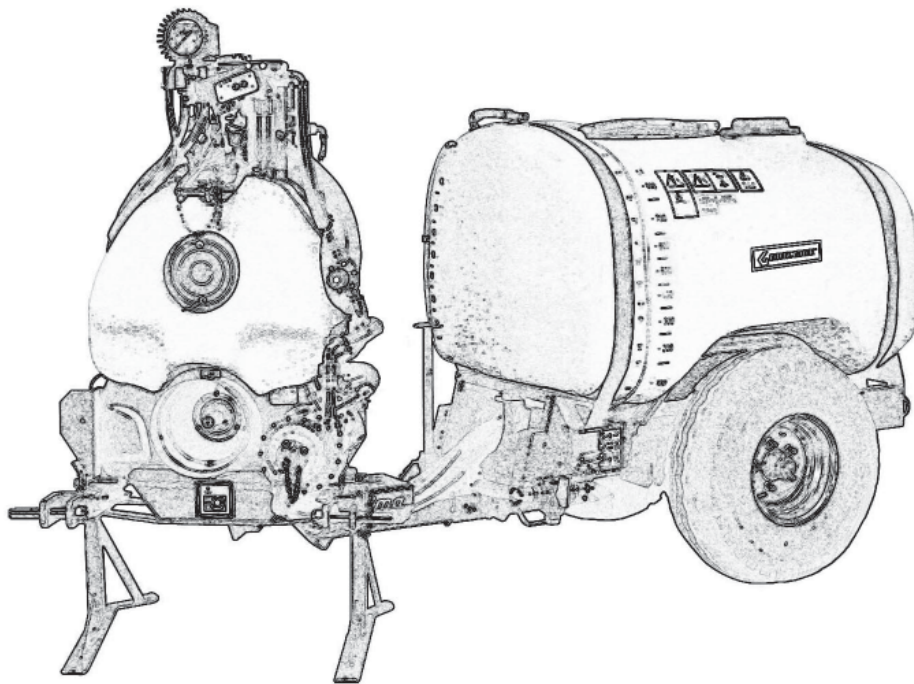

**Parts Manual For
Model L50N1-800
200 Gallon Capacity**

July 2013

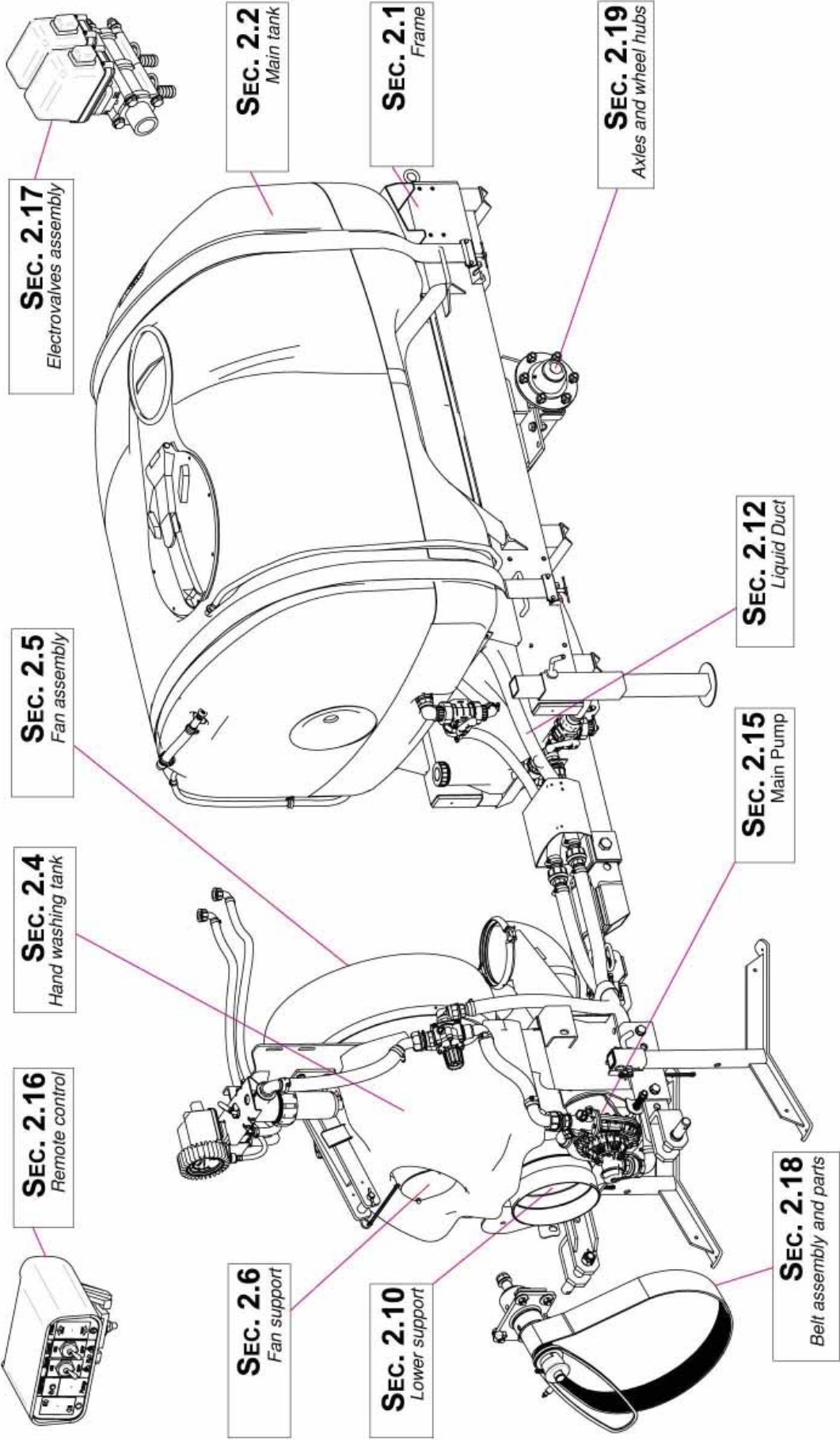

TABLE OF CONTENTS

<u>SECTION</u>	<u>DESCRIPTION</u>	<u>PAGE</u>
1	Introduction	1
1.1	Purchaser's Responsibility	1
1.2	Serial Number Information	1
2	Replacement Parts	2 - 29
2.1	Frame Assembly.....	2-4
2.2	Tank Assembly.....	5-6
2.3	Tank Fittings & Cover	7-8
2.4	Hand Wash Tank	9
2.5	Fan Housing Assembly.....	10
2.6	Fan Support Assembly.....	11
2.7	Fan Support Breakdown.....	12
2.8	Belt Tension Roller	13
2.9	Lubrication Tubing.....	14
2.10	Main Pulley	15
2.11	Overrunning Clutch	16
2.12	Liquid Flow Path	17-19
2.13	Pressure Regulator & 3 Way Valve.....	20
2.14	Suction Filter Assembly.....	21
2.15	Pump Assembly	22-23
2.16	Control Valve	24
2.17	Electro Valves.....	25-26
2.18	Pump & Fan Belts	27
2.19	Axle & Wheel Hubs	28
2.20	Driveshaft	29
3	Limited Warranty	30

1 INTRODUCTION

This manual contains parts diagrams and replacement parts lists. Do not modify the equipment in any way. Unauthorized modification may impair the function and/or safety and could affect the life of the equipment.

It is the responsibility of the owner to make sure the machine is maintained properly, and that all parts are in working order.

Where replacement parts are necessary for periodic maintenance and servicing, genuine factory replacement parts ***MUST*** be used to restore your equipment to original specifications. The manufacturer will not be responsible for injuries or damages caused by use of unapproved parts and/or accessories.

The manufacturer reserves the right to make improvements to the machinery and parts at any time and at their discretion.

OPERATOR ORIENTATION - The directions left, right, front and rear, are as seen from the driver's seat and facing in the direction of travel.

1.1 PURCHASER'S RESPONSIBILITY

It is the responsibility of the purchaser and/or operator to.....

- Inspect the equipment and replace or repair any parts that are damaged or worn which under continued operation would cause damage, wear to other parts, or cause a safety hazard.
- Return the equipment or parts to the authorized dealer, from where it was purchased, for service or replacement of defective parts that are covered by warranty. (The factory may inspect equipment or parts before warranty claims are honored.)
- Payment of all costs incurred by the dealer for traveling to or transporting the equipment for warranty inspection and or claims.

1.2 MODEL / SERIAL NUMBER

NAME: _____

PURCHASED FROM: _____

DATE OF PURCHASE: _____

MODEL NUMBER: _____

SERIAL NUMBER: _____

2 REPLACEMENT PARTS

2.1 MAIN FRAME ASSEMBLY

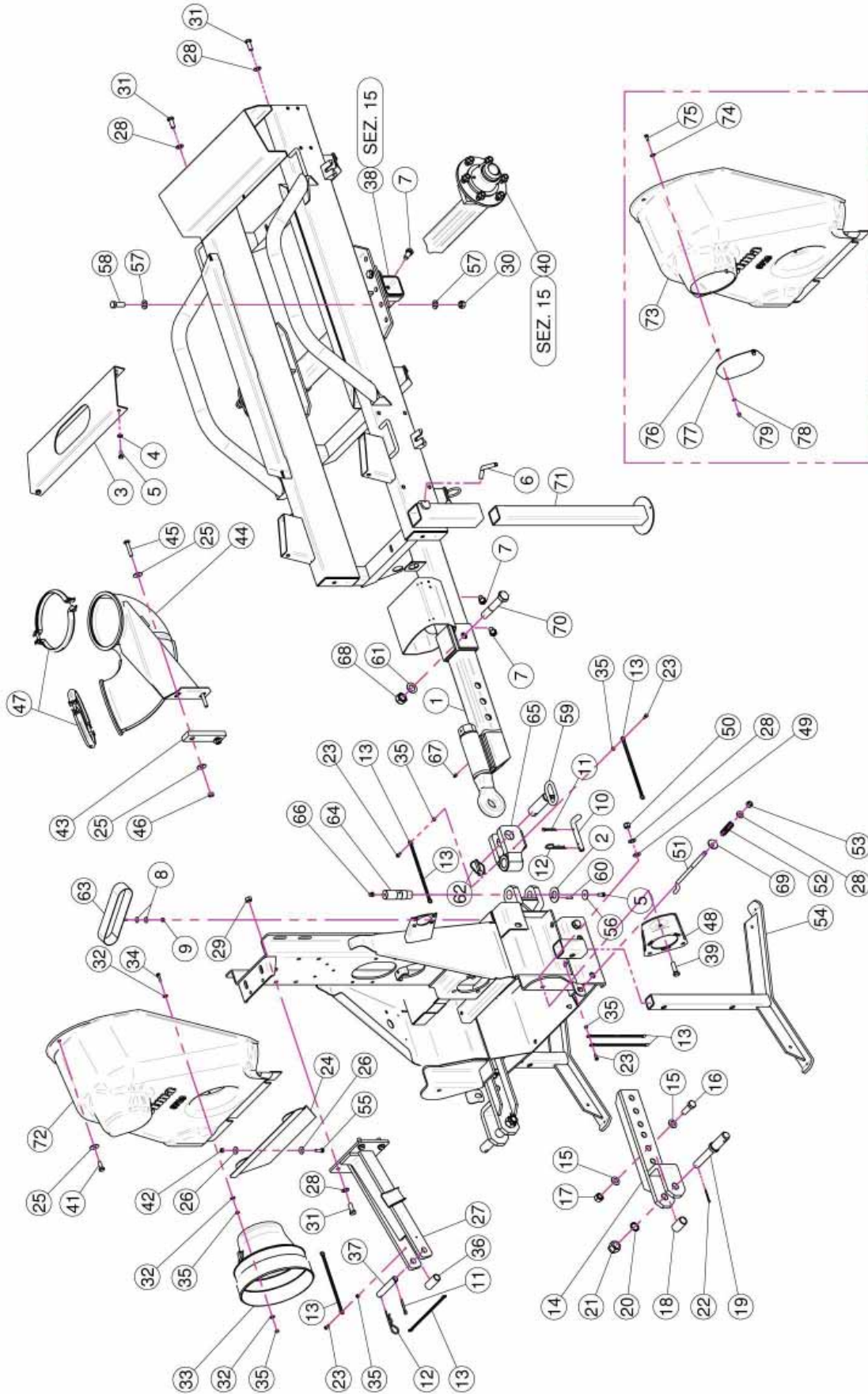

2.1 FRAME ASSEMBLY

<u>REF.</u>	<u>QTY.</u>	<u>PART NO.</u>	<u>DESCRIPTION</u>
1	1	40.131.700	Drawbar
2	1	40.206.000	Joint Washer
3	1	40.242.000	Plate
4	4	RP.008.000	Washer D.8
5	5	TE.008.020T	Screw TE 8 x 20
6	1	02.175.000	Looking Handle
7	6	TE.014.030T	Screw TE M14 x 30
8	2	RP.006.018	Washer D.6 x 18
9	1	DA.006.0AG	Self Locking Nut - High M6
10	2	20.505.000	Pin Jack Stand
11	3	CP.006.040I	Pin D.6 Lg. 40
12	3	00.100.004	Split Pin D.4
13	8	21.183.000	Cap Stop
14	2	40.203.000	Fork
15	8	RP.016.000	Washer D.16
16	4	TE.016.050T	Screw TE M16 x 50
17	4	D0.16.5587G	Nut M16
18	2	40.202.000	Bush
19	2	40.201.000	Pin Power Lift
20	2	RD.022.000	Tab Washer D.22
21	2	DI.022.5593F	Castle Nut (6 Slots) M22
22	2	CP.004.040	Split Pin D.4 L=40
23	5	TE.006.016T	Screw TE M6 x 16
24	1	05.747.000	Housing Fixing Plate
25	5	RP.010.030	Washer D.10 x 30 mm
26	4	RP.008.024	Washer D.8 x 24
27	1	40.205.001	Upper Coupling
28	8	RP.012.000	Washer D.12
29	4	D0.12.5587G	M12 Nut
30	4	D0.14.5587G	Nut M14
31	6	TE.012.030T	Screw TE 12 x 30
32	9	RD.006.000	Tab Washer D.6
33	1	02.441.000	Shaft Cone D.240
34	3	TE.006.025T	Screw TE M6 x 25
35	11	D0.06.5588G	Nut M6
36	1	20.778.000	Bush
37	1	04.076.000	Pin
38	1	40.126.000	Axle
39	1	TE.012.040T	Bolt TE M12 x 40
40	2	40.020.150	Hub 6 Colonnette
41	1	TE.010.025T	Screw TE 10 x 25T
42	2	D0.08.5588G	Nut M8

2.1 FRAME ASSEMBLY

<u>REF.</u>	<u>QTY.</u>	<u>PART NO.</u>	<u>DESCRIPTION</u>
43	1	02.992.000	Bracket
44	1	04.882.000	Lower Bend D.175
45	2	TE.010.050T	Screw M10 - 50
46	2	D0.10.5587G	Nut M10
47	2	05.616.000	Pipe Clamp D.175
48	1	02.978.000SX	Bracket
49	1	MT.012.000	Washer D.12
50	1	DA.012.0AG	Self Locking Nut M12
51	1	21.004.000	Belt Stretcher For Pump
52	1	02.964.000	CD 32 Pump Spring
53	1	DOT.12.5587	M12 Brass Nut
54	2	40.217.001	Support Foot
55	2	TE.008.025T	Screw TE M8 x 25
56	1	RP.008.032	Washer D.8 x 32
57	8	RP.014.000	Washer D.14
58	4	TE.014.040T	Screw TE M14 x 40
59	1	20.309.200	Pin Ø32
60	1	SE.005.026	Spring Pin D5 x 26
61	1	RP.022.000	Washer D.22
62	1	02.439.000	Pin D.10
63	1	20.785.100	Guide Ring
64	1	40.332.001	Vertical Pin
65	1	40.194.200	Joint
66	1	IS.010.001	Greaser
67	1	ID.006.001	Greaser
68	1	DA.022.0BG	Self Locking Nut M22
69	1	21.113.000	Washer D.12 x 36
70	1	TE.022.130	Screw DIN EN 24016 - M22 x 130
71	1	40.251.001	Support Foot
72	1	05.723.150	Front Housing For 1 Pump
73	1	05.723.050	Front Housing For 1 Pump
74	2	RD.006.000	Tab Washer D.6
75	2	TE.006.016T	Screw TE M6 x 16
76	2	D0.06.5589G	Nut M6
77	1	40.333.000	Fan Clutch Lid
78	2	RP.006.000	Washer D.6
79	2	DC.06.5721I	Nut DIN 1587 6 x 1-6-10

2.2 MAIN TANK ASSEMBLY

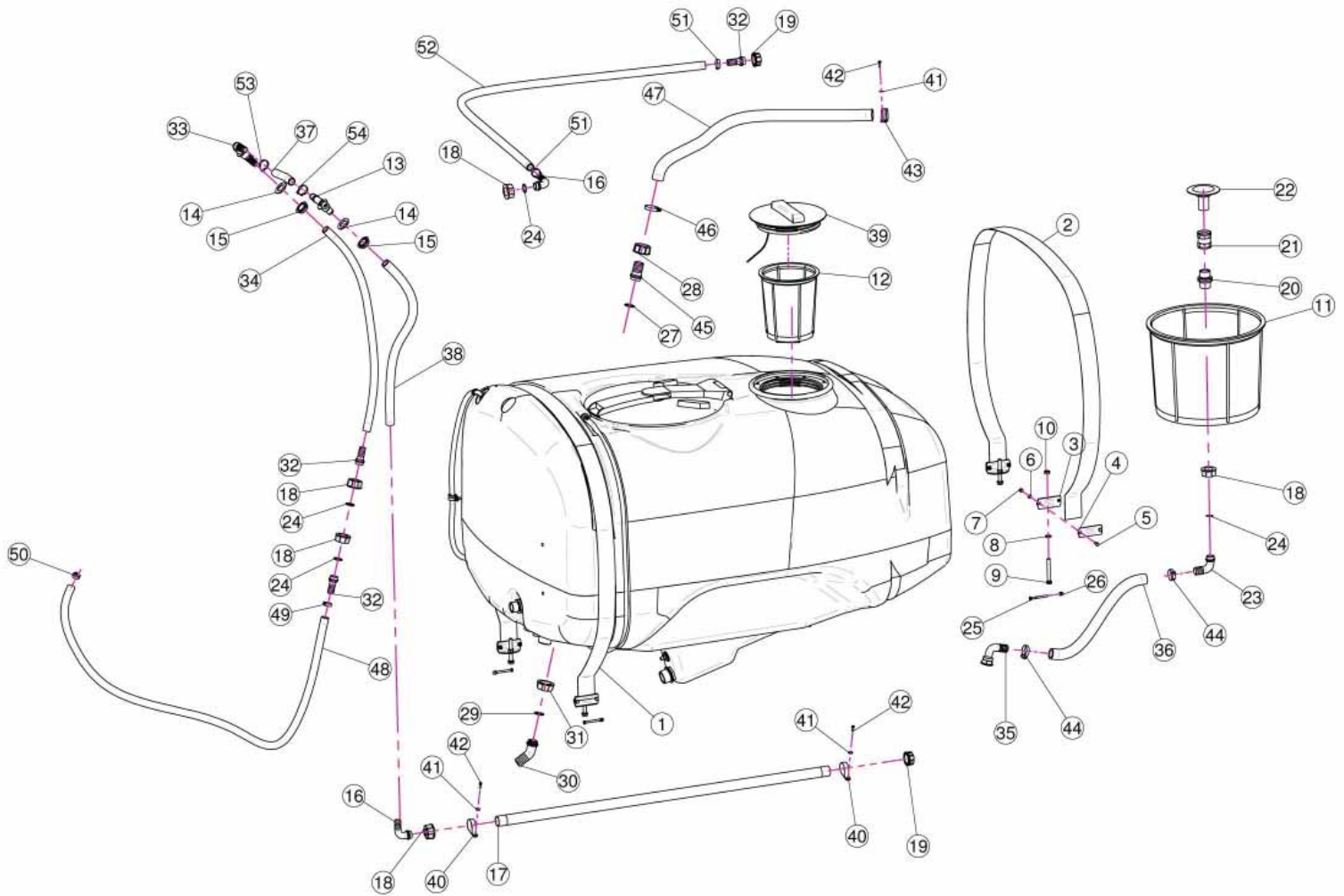

<u>REF.</u>	<u>QTY.</u>	<u>PART NO.</u>	<u>DESCRIPTION</u>
1	1	02.481.283	Nylon Band 60 mm L=2830
2	1	02.481.263	Nylon Band 60 mm L=2630
3	4	20.512.000	Bracket
4	4	20.513.000	Shaped Plate
5	8	TE.006.020T	Screw TE M6 x 20
6	8	RP.006.000	Washer D.6
7	8	DA.006.0AG	Self Locking Nut - High M6
8	4	RP.010.000	Washer D.10
9	4	TE.010.080T	Bolt M10 x 80
10	4	DOT.10.5587	M10 Brass Nut
11	1	02.404.100	Basket Filter 400 x 330
12	1	02.298.000	Basket Filter D.204
13	1	02.135.000	Complete Piston Valve
14	2	02.032.000	Gasket D.26 x 40 Sp.2
15	2	00.541.000	Nut 3/4"

2.2 MAIN TANK ASSEMBLY

<u>REF.</u>	<u>QTY.</u>	<u>PART NO.</u>	<u>DESCRIPTION</u>
16	2	00.055.038	Curved Union With R.H. D.19
17	1	40.035.001	Perforated Hose 1" L=1200
18	5	00.055.24.2	1" Fly Nut
19	2	TF.001.000	Packing
20	1	00.055.034	Nipple 1" / 1" GAS
21	1	00.373.000	1" Gas Sleeve
22	1	00.131.000	1" Vortex Damper Drive
23	1	00.055.037	D.25 Hosetail
24	4	OR.000.132	23.81 x 2.62 O-Ring Gasket
25	4	TE.006.060I	INOX M6 x 60 TE Screw
26	4	DC.06.5721I	Nut DIN 1587 6 x 1-6-10
27	1	OR.003.112	O-Ring D.28.24 x 2.62
28	1	00.058.006	1" 1/4 Fly Nut
29	1	OR.003.106	O-Ring D.26.65 x 2.62
30	1	02.339.000	45° Hosetail
31	1	00.493.000	1" 1/4 Fly Nut
32	3	00.055.022	Straight Hose R.H. D.19
33	1	02.290.000	Hosetail D.19 3/4" Male
34	As Req'd	02.212.000	Hose D.19 x 26 L=700 (Per Foot)
35	1	20.794.000	Pipe 90° R.H. 25 3/4" GAS F
36	As Req'd	20.809.000	Hose D25 x 35 L=1100 (Per Foot)
37	As Req'd	20.212.000	Hose D.19 x 26 L=200 (Per Foot)
38	As Req'd	20.212.000	Hose D.19 x 26 L=750 (Per Foot)
39	1	02.476.100	Threaded Lid D.255 With Rope
40	2	FN.035.000	Sticker
41	3	RP.005.015I	Washer D.5 x 15
42	3	TE.005.016I	Screw TE M5 x 16
43	1	FG.040.000	Sticker
44	2	F0.023.035I	Stainless Steel Clip
45	1	00.058.028	Straight Hose R.H. D.30
46	1	F0.025.040I	Stainless Steel Clip
47	As Req'd	02.238.000	Hose D.30 L=1200 (Per Foot)
48	As Req'd	02.372.000	Hose D.19 L=1600 (Per Foot)
49	2	FC.023.5.025	Hose Clamp 23.5 - 25
50	1	FC.022.5.024	Hose Clamp 22.5 - 24
51	2	FC.026.5.028	Hose Clamp 26.5 - 28
52	As Req'd	02.212.000	Hose D.19 x 26 L=700 (Per Foot)
53	1	FC.030.5.032	Hose Clamp 30.5 - 32
54	2	FC.027.5.029	Hose Clamp 27.08 - WB

2.3 TANK FITTINGS & COVERS

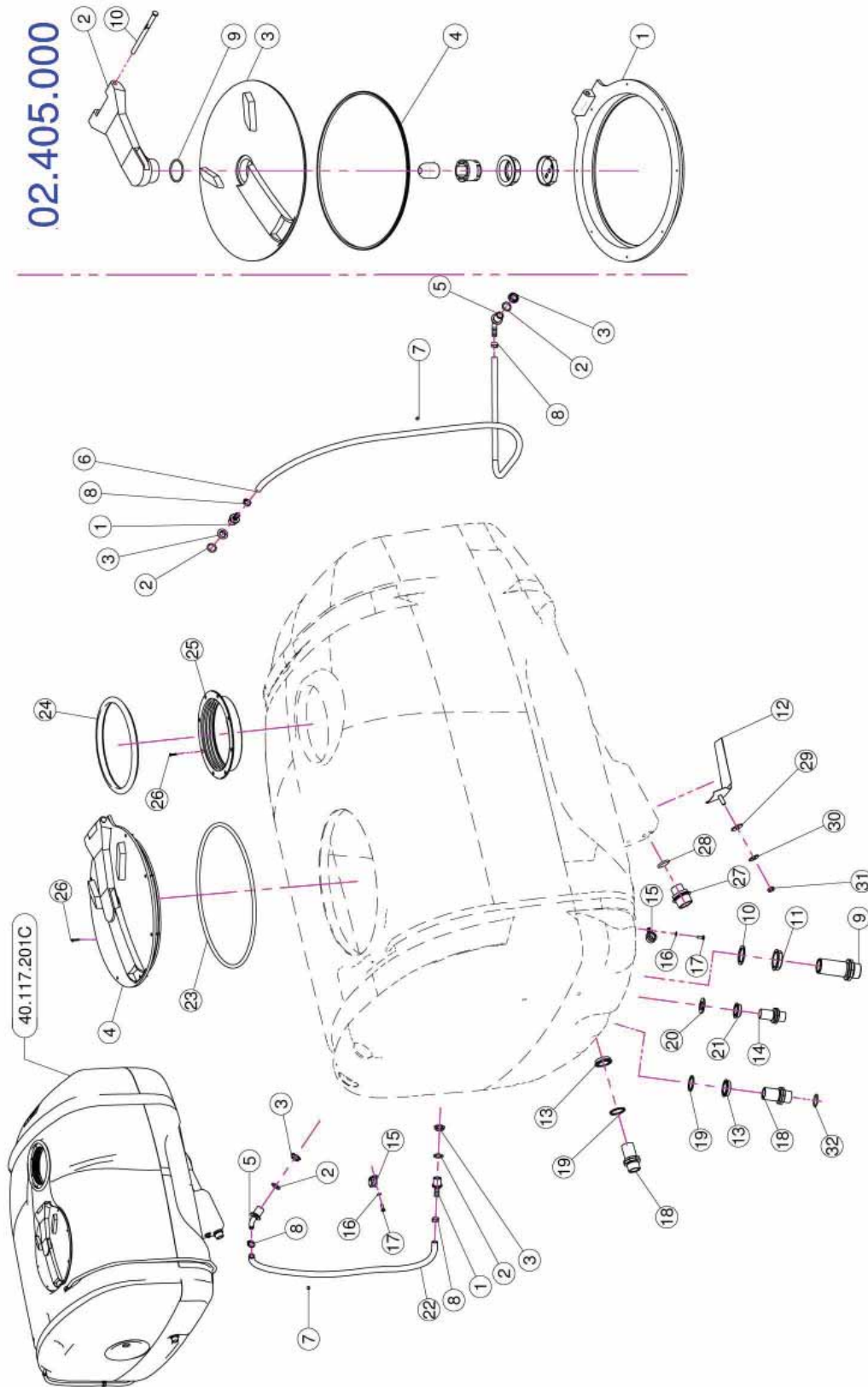

2.3 TANK FITTINGS & COVERS

<u>REF.</u>	<u>QTY.</u>	<u>PART NO.</u>	<u>DESCRIPTION</u>
1	2	02.482.000	Hosetail Male Threaded 1/2"
2	4	OR.004.081	20.22 x 3.53 O-Ring Gasket
3	4	02.458.000	Lock Ring 1/2"
4	1	02.405.000	Hinged Tank Lid
5	2	02.457.000	Hosetail D.13 90° M. 1/2"
6	1	02.378.000	Hose D.12 x 16 L=1600 (Per Foot)
7	2	02.478.000	Red Floating Ball D.8.5
8	4	FC.016.5.018	Hose Clamp 16.5 - 18
9	1	00.345.000	Nipple 1" 1/4 + 1" 1/4 GAS
10	1	02.033.000	Gasket
11	1	00.543.000	Nut 1" 1/4 GAS
12	1	20.498.002	Stainless Steel Anti-Vortex
13	2	00.542.000	Nut 1"
14	1	02.380.100	Nipple 3/4"
15	2	FG.018.000	Sticker
16	2	RP.006.000	Washer D.6
17	2	TE.006.016T	Screw TE M6 x 16
18	2	00.055.134.L	Cutted Long Nipple 1" / 1" GAS
19	2	02.066.000	Gasket D.33 x 45
20	1	02.032.000	Gasket D.26 x 40 Sp. 2
21	1	00.541.000	Nut 3/4"
22	As Req'd	02.378.000	Hose D. 12 x 16 L=850 (Per Foot)
23	1	02.405.000.L	Gasket
24	1	02.477.000.A	Threaded Ring Gasket D.255
25	2	02.477.000	Threaded Ring D.255
26	16	TAS.04.2.025I	Self Threaded Screw 4.2 x 25
27	1	00.045.012	1" 1/4 M - 1" M Reducer Nipple
28	1	OR.000.507	27 x 5 O-Ring Gasket
29	1	20.436.000	Special Garnishing For Anti-Whirl
30	1	RP.010.030	Washer D.10 x 30 mm
31	1	DOT.10.5587	M10 Brass Nut
32	1	OR.004.118	29.75 x 3.53 O-Ring Gasket

02.405.000 MAIN LID ASSEMBLY

1	1	02.405.000.B	Base Ring
2	1	02.405.001	Arm
3	1	02.405.000.A	Gripping Plate
4	1	02.405.002	Shaped Gasket
9	1	OR.000.512	51 x 3.5 O-Ring Gasket
10	1	20.787.000.D	Pin

2.4 HAND WASH TANK

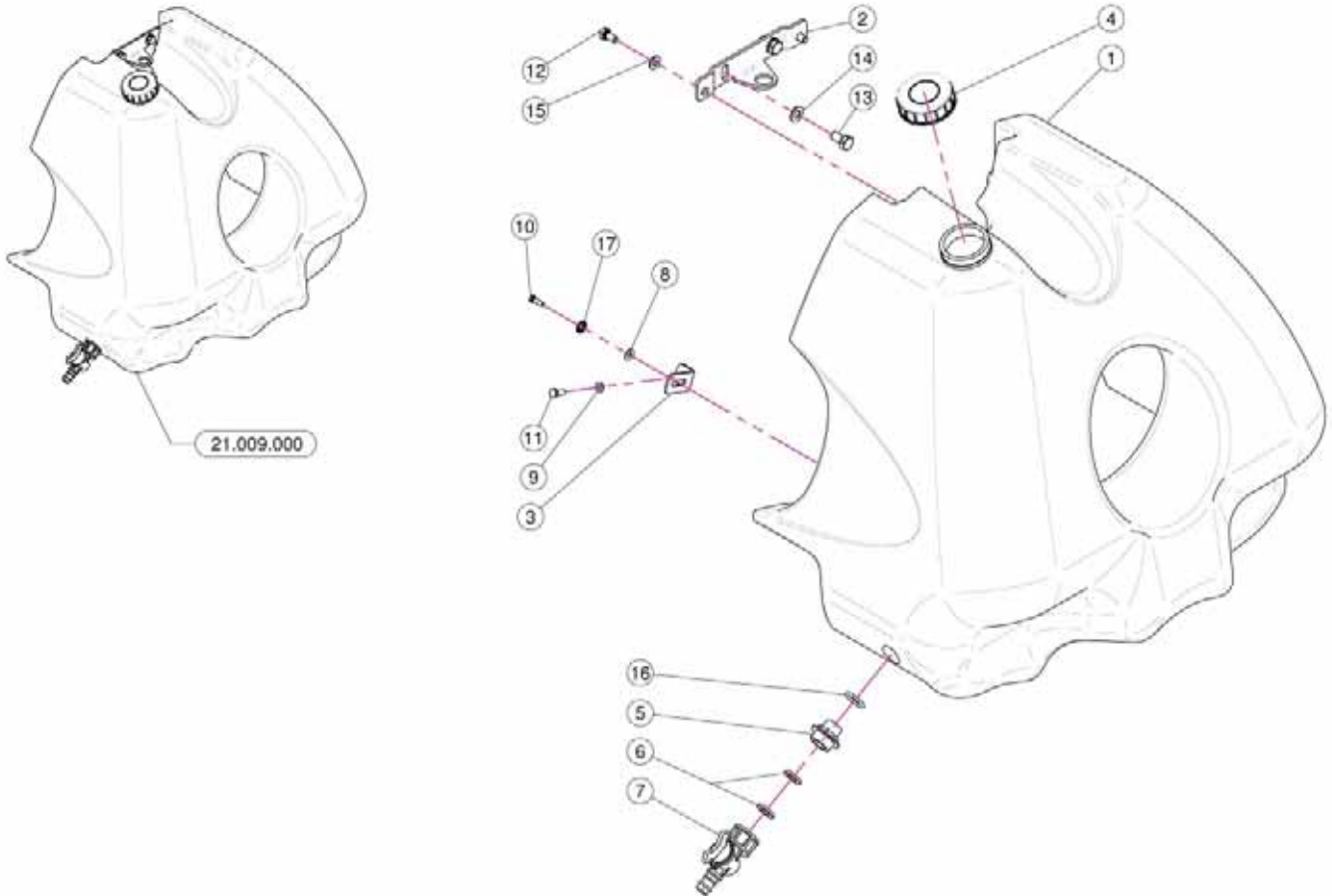

<u>REF.</u>	<u>QTY.</u>	<u>PART NO.</u>	<u>DESCRIPTION</u>
1	1	40.322.000	Hand Washing Tank
2	1	40.323.000	Fixing Bracket
3	2	40.324.100	Bracket
4	1	02.460.000	Female Threaded Tank Lid
5	1	00.055.044	Nipple 1/2" - 3/4" GAS
6	2	02.030.010	Gasket
7	1	02.497.000	3/4" Female Valve
8	2	RP.005.015I	Washer D.5 x 15
9	2	RP.006.000	Washer D.6
10	2	TE.005.016I	Screw TE M5 x 16
11	2	TE.006.016T	Screw TE M6 x 16
12	2	TE.008.016T	Screw TE M8 x 16
13	2	TE.010.020T	Screw TE M10 x 20
14	2	RP.010.000	Washer D.10
15	2	RP.008.000	Washer D.8
16	1	OR.004.081	20.22 x 3.53 O-Ring Gasket
17	2	RD.006.000	Tab Washer D.6

2.5 FAN HOUSING ASSEMBLY

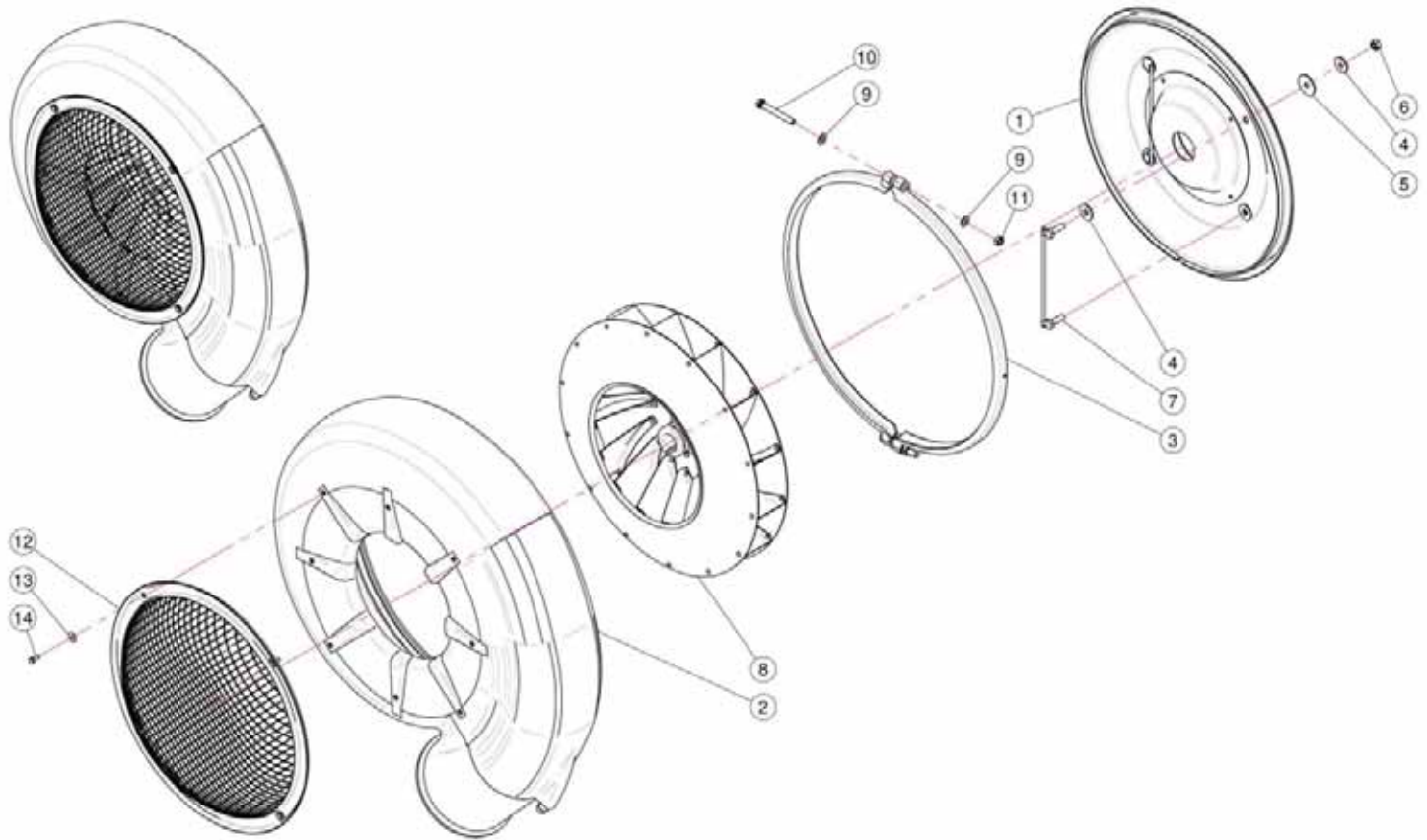

<u>REF.</u>	<u>QTY.</u>	<u>PART NO.</u>	<u>DESCRIPTION</u>
1	1	50.120.000	Fan 50 Cover
2	1	05.730.000	50 Fan Housing
3	1	05.731.000Z	D.535 Clamp
4	8	RP.010.030	Washer D.10 x 30 mm
5	4	RP.010.040	Washer D.10 x 40
6	4	D0.10.5587G	Nut M10
7	2	20.088.000	Back Cover Bracket
8	1	05.732.000	Fan 50
9	4	RP.010.000	Washer D.10
10	2	TE.010.080T	M10 x 80 Bolt
11	2	DOT.10.5587	M10 Brass Nut
12	1	05.654.200	Fan Net Protection
13	4	RP.006.018	Washer D.6 x 18
14	4	TE.006.016T	Screw TE M6 x 16

2.6 FAN SUPPORT ASSEMBLY

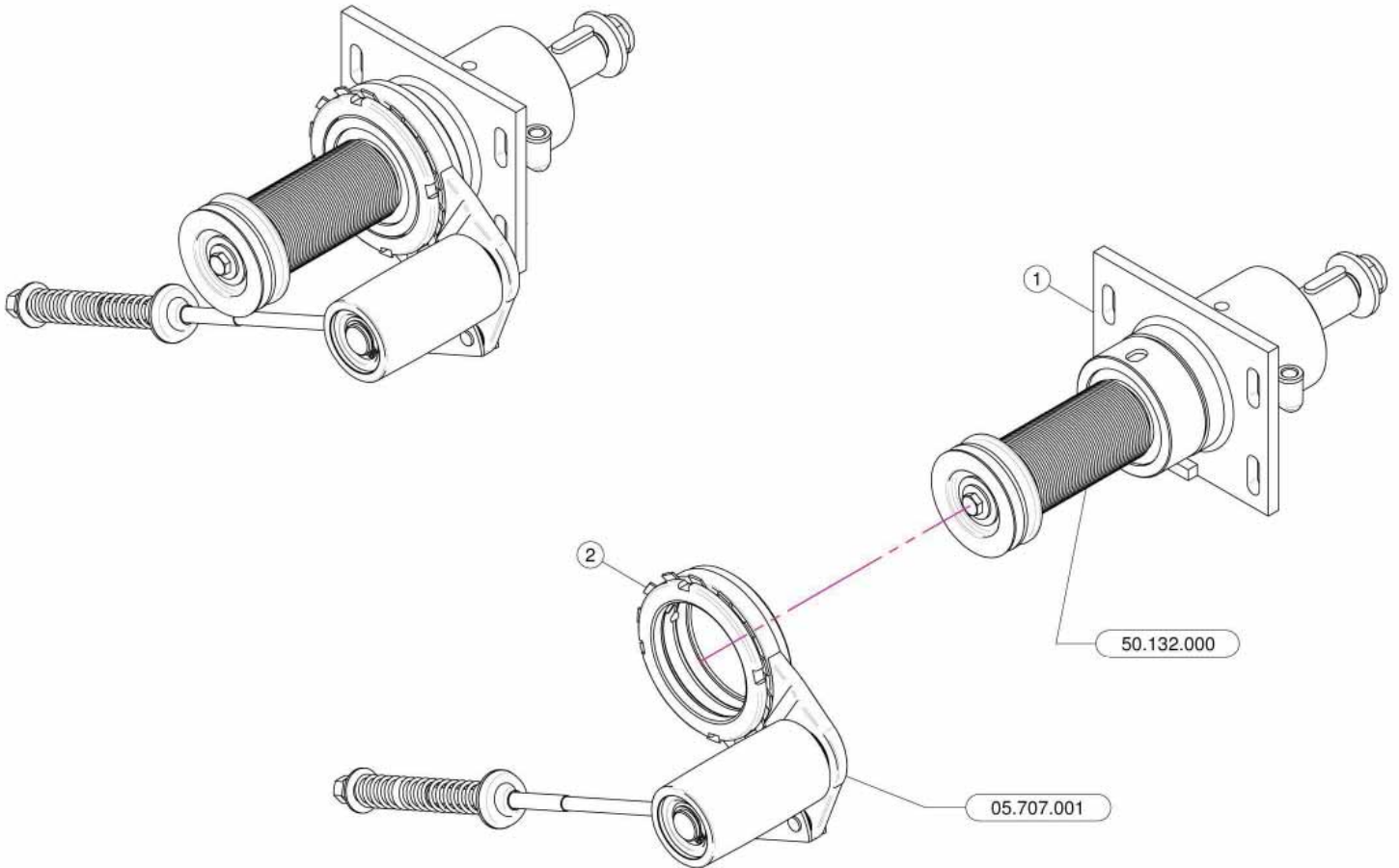

<u>REF.</u>	<u>QTY.</u>	<u>PART NO.</u>	<u>DESCRIPTION</u>
1	1	50.132.000	Fan Support With Shaft - Pul D.64.5
2	1	05.707.001	Automatic Belt Stretcher

2.7 FAN SUPPORT BREAKDOWN

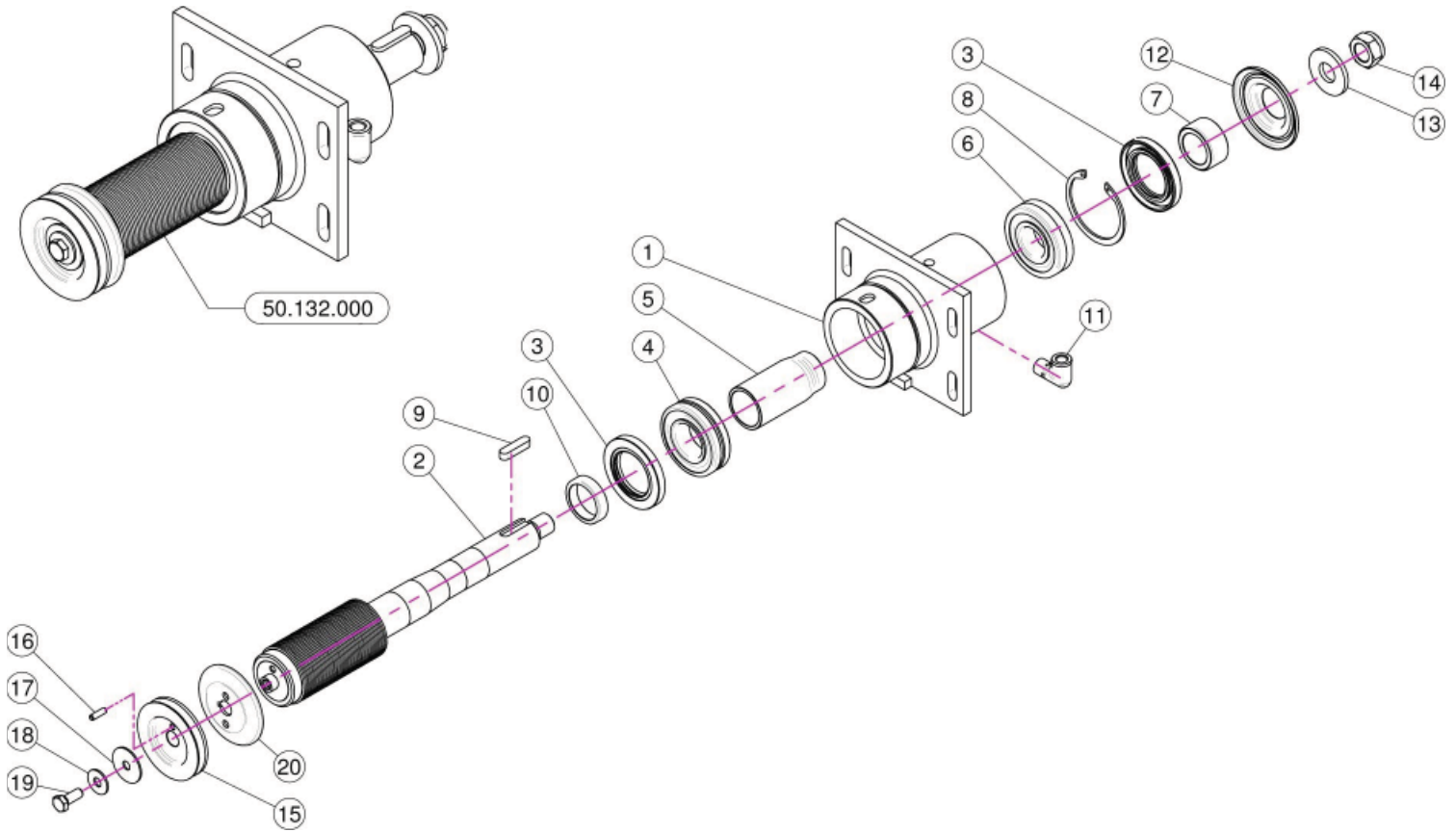

<u>REF.</u>	<u>QTY.</u>	<u>PART NO.</u>	<u>DESCRIPTION</u>
1	1	50.110.000	Housing Fan Support
2	1	50.119.064.5	Shaft With Pulley D.64.5
3	2	BASL.50.80.10	Viton Lip Seals -IEL (50-80-10)
4	1	K0.022.208	Roller Bearing 22-208
5	1	50.112.000	Spacer
6	1	K0.021.307	Roller Bearing 21-307
7	1	50.113.000	Spacer
8	1	I0.080.000	Internal D.80 Circlip
9	1	L.10.08.40	Feather Key 10 x 8 x 40
10	1	50.114.000	Spacer
11	1	20.789.000	Male/Female 90° Elbow
12	1	50.115.000	Dust Cover
13	1	20.820.000	Washer
14	1	DA.022.0BF	Self-Locking Nut M22 x 1.5
15	1	05.816.000	Pulley For Pump D.88 (1 x 3V)
16	1	SE.006.020	Spring Pin D.6 x 20
17	1	RP.010.040	Washer D.10 x 40
18	1	RP.010.028	Washer D.10 x 28
19	1	TE.010.025FT	Bolt TE M10 x 25
20	1	02.723.000A	Semi Pulley D.88

2.8 BELT TENSION ROLLER

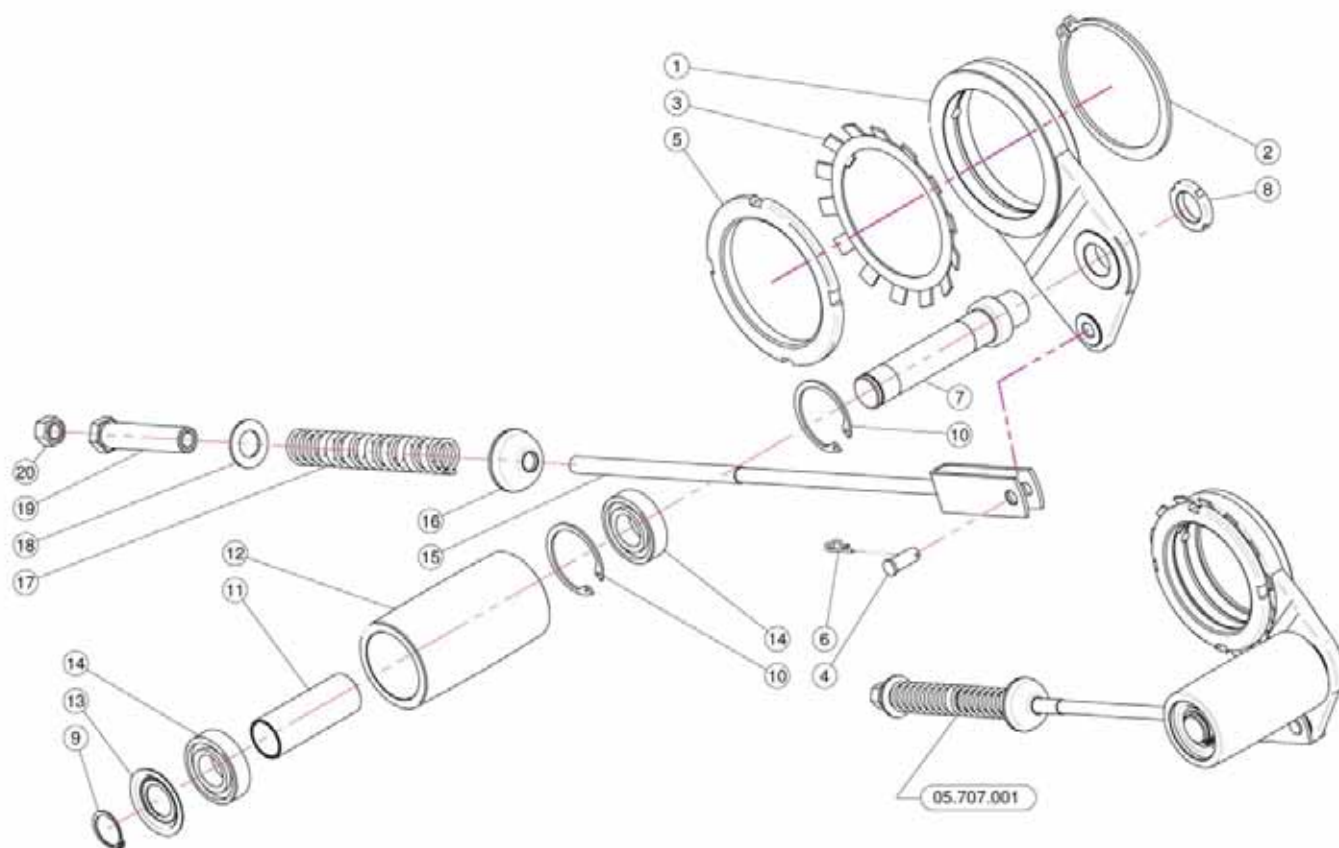

<u>REF.</u>	<u>QTY.</u>	<u>PART NO.</u>	<u>DESCRIPTION</u>
1	1	05.696.000	Idler Support
2	1	E0.100.000	External D.100 Circlip
3	1	MB.020.000	Tooth Lock Washer
4	1	04.593.000	Pin
5	1	05.704.000	Register Nut
6	1	00.100.002	Clip
7	1	05.697.000	Pivot
8	1	KM.005.000	Nut KM5
9	1	E0.025.000	External D.25 Circlip
10	2	I0.052.000	Internal D.52 Circlip
11	1	05.631.101	Spacer
12	1	05.630.000	Roller
13	1	04.585.000	Anti-Dust Cover
14	2	K6.205.2RS	Roller Bearing 6205-2RS
15	1	05.653.000	Belt Stretcher Fork
16	1	20.260.000	Special Washer D.12
17	1	04.093.000	Spring
18	1	RP.019.000	Washer D.19
19	1	04.583.000	Special Screw
20	1	D0.12.5587G	M12 Nut

2.9 LUBRICATION TUBING

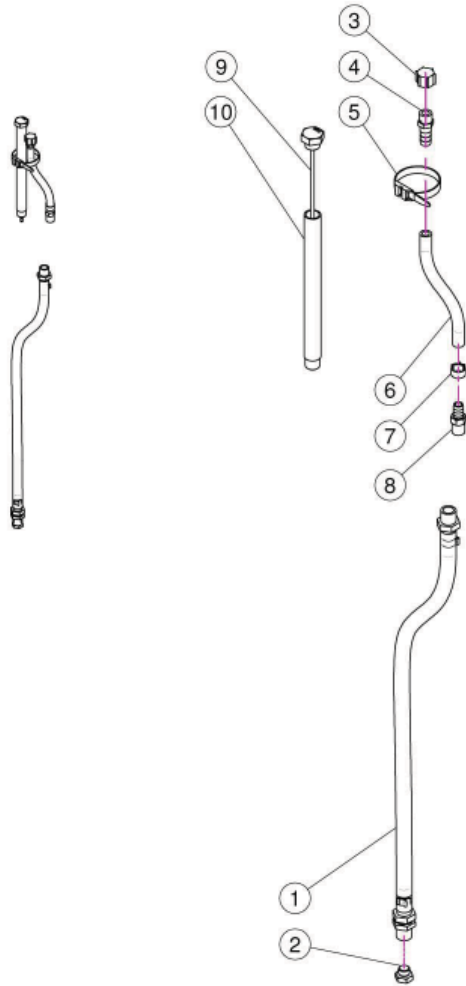

<u>REF.</u>	<u>QTY.</u>	<u>PART NO.</u>	<u>DESCRIPTION</u>
1	1	20.790.000	Drain Pipe 3/8"
2	1	40.266.000	Oil Exhaust Plug
3	1	02.013.000	Plug G1/4"
4	1	00.414.100	Straight Hose D.11 1/4" With Bleed
5	1	02.355.000	Nylon Assembly Clamp
6	As Req'd	02.217.000	Hose D.8 x 13 L=250 (Per Foot)
7	1	FC.014.5.016	Hose Clamp
8	1	20.792.000	Straight Hose D.11 G 1/4" For Breather
9	1	50.116.000	Filling Plug With Dipstick
10	1	50.122.000	Filling Pipe L=451

2.10 MAIN PULLEY

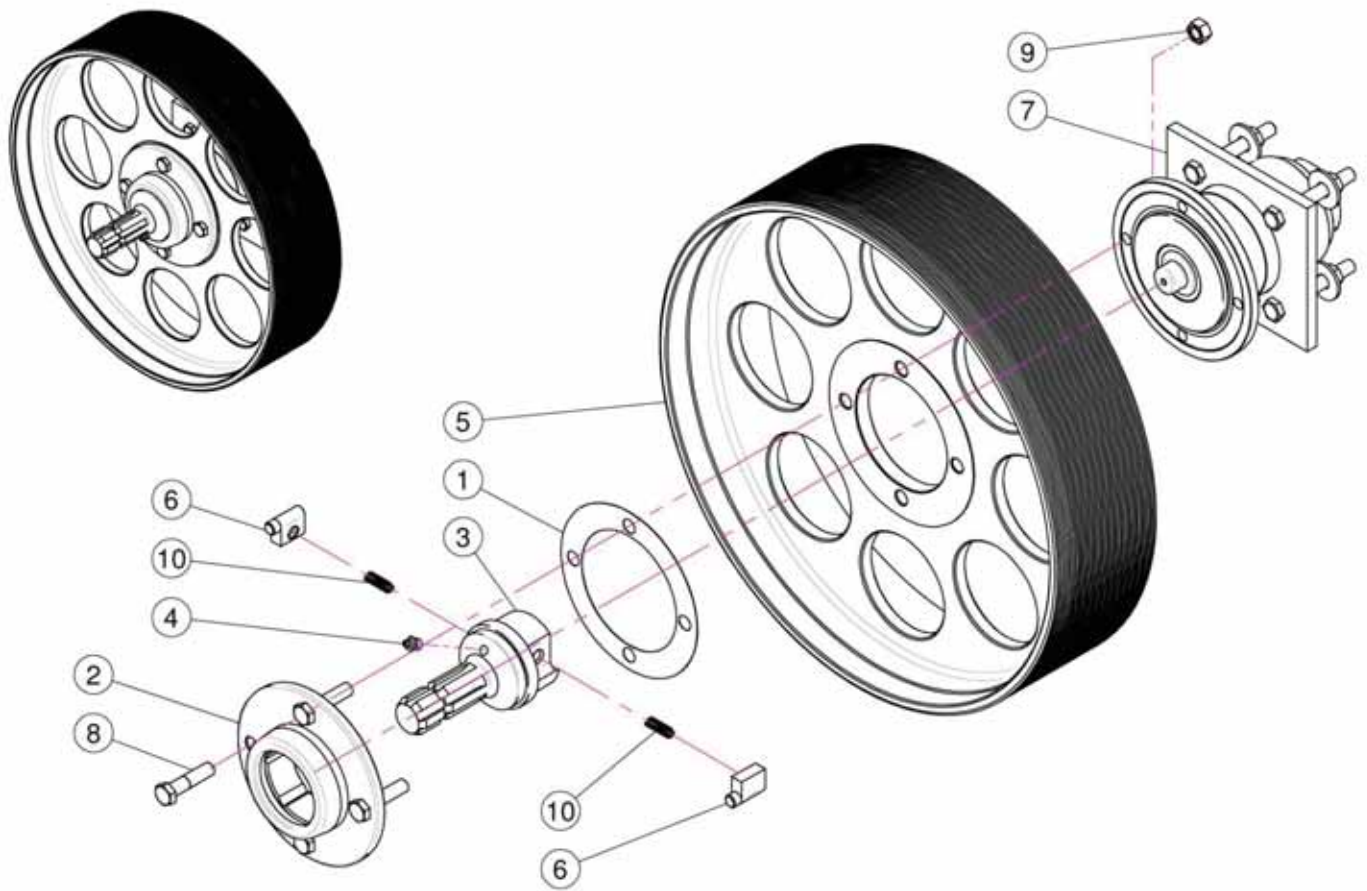

<u>REF.</u>	<u>QTY.</u>	<u>PART NO.</u>	<u>DESCRIPTION</u>
1	1	04.719.000	Gasket
2	1	04.066.000	Body
3	1	03.701.000	Rotor
4	1	ID.010.001	Grease Nipple
5	1	00.480.J50	Pulley Diameter 480 J 50
6	2	02.502.002	Pin
7	1	05.632.01C	Clutch
8	4	TE.012.050F	Bolt M12 x 50
9	4	DO.12.5587F	Nut M12 PG 5587F
10	2	02.502.001	Spring

2.11 OVERRUNNING CLUTCH

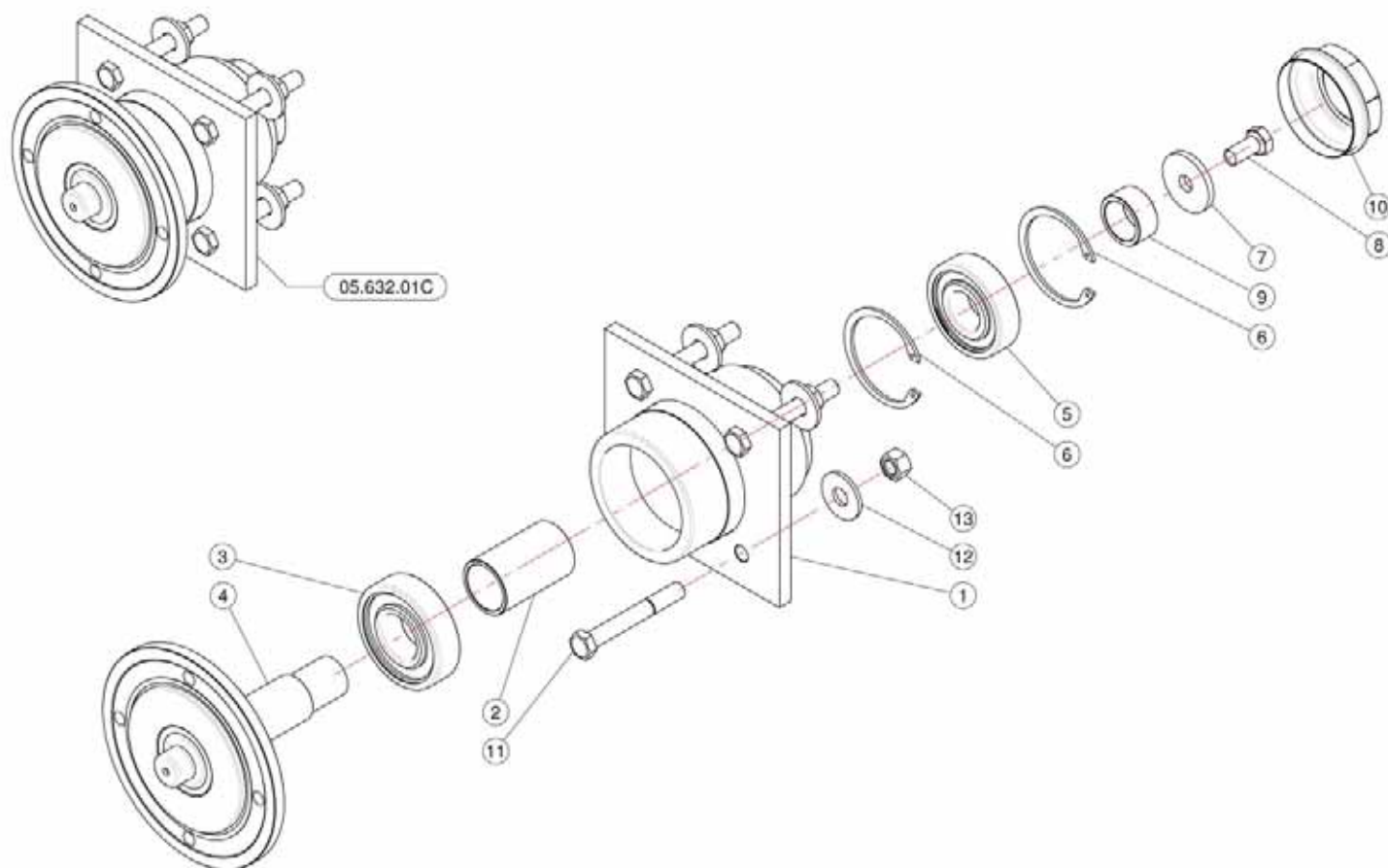

<u>REF.</u>	<u>QTY.</u>	<u>PART NO.</u>	<u>DESCRIPTION</u>
1	1	05.632.000	Lower Support
2	1	04.565.000	Lower Shaft Spacing Bar
3	1	K6.307.2RS	Bearing
4	1	04.589.000	Lower Shaft
5	1	K6.306.2RS	Bearing
6	2	I0.072.000	Spacing Bar
7	1	20.810.000	Special Washer For Lower Support
8	1	TE.012.025FT	Bolt TE M12 x 1.25
9	1	04.590.000	Spacer
10	1	04.555.001	Cover
11	4	TE.012.090	Screw TE M12 x 90
12	4	RP.012.036	Washer D12 x 36
13	4	D0.12.5587G	M12 Nut

2.12 LIQUID FLOW PATH

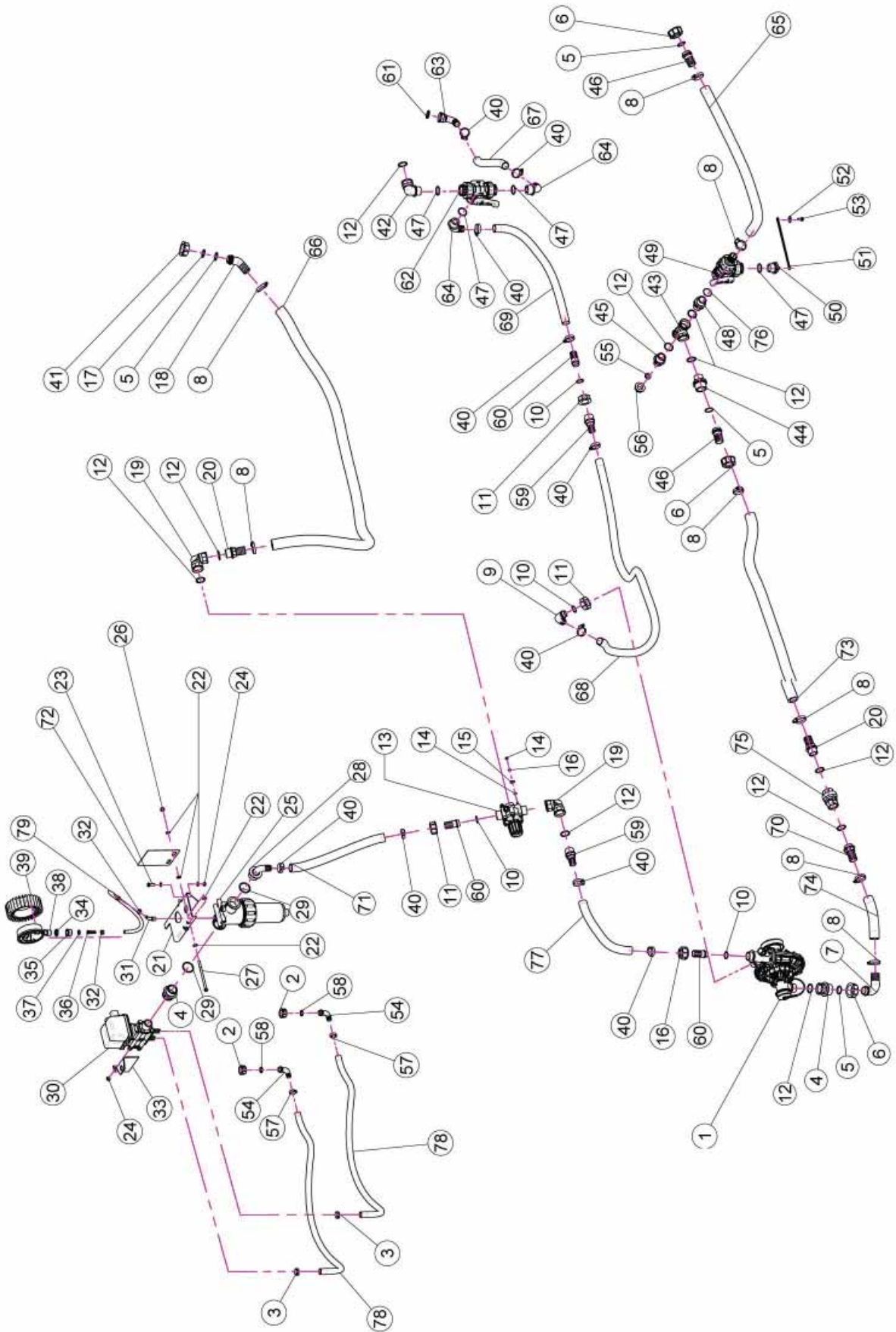

2.12 LIQUID FLOW PATH

<u>REF.</u>	<u>QTY.</u>	<u>PART NO.</u>	<u>DESCRIPTION</u>
1	1	02.157.073	Pump
2	2	00.055.045	3/4" Fly Nut
3	2	FC.021.5.023	Hose Clamp 21.5 - 23
4	2	02.374.000	M./F. 1" F/ 1"1/4M Reduction
5	4	OR.003.112	O-Ring D.28.24 x 2.62
6	3	00.058.006	1" 1/4 Fly Nut
7	1	00.058.004	D.30 Hosetail
8	8	F0.025.040I	Stainless Steel Clip
9	1	00.055.037	D.25 Hosetail
10	4	OR.000.132	23.81 x 2.62 O-Ring Gasket
11	4	00.055.24.2	1" Fly Nut
12	10	OR.004.118	29.75 x 3.53 O-Ring Gasket
13	1	02.447.000	3 Way Valve
14	8	D0.06.5588G	Nut M6
15	4	RP.006.018	Washer D.6 x 18
16	4	RP.006.000	Washer D.6
17	1	OR.003.106	O-Ring D.26.65 x 2.62
18	1	02.339.000	45° Hosetail
19	2	02.291.000	Female Hosetail Thread 1"
20	2	00.422.000	Male Connector RH 30 1" GAS
21	1	20.424.300	Bracket For Regulation Group'
22	12	RP.008.000	Washer D.8
23	2	TE.008.025T	Screw TE M8 x 25
24	4	D0.08.5588G	Nut M8
25	1	02.450.110	Line Filter 1" 1/4 Female
26	2	DA.008.0AG	Self Locking Nut M8
27	2	TE.008.130	Screw M8 x 130
28	1	20.819.000	D.25 Hosetail
29	2	OR.000.144	O-Ring D.39.69 x 3.53
30	1	02.390.08C	Electro Valves
31	1	21.084.000	Hosetail 90° Wes 8/R1/4
32	2	FC.013.5.015	Hose Clamp
33	1	40.304.000	Fixing Bracket
34	1	24.072.000	Brass Fly Nut 1/2"
35	1	02.287.000	Fly Nut 1/2"
36	1	02.379.020	Straight Union R.H. 10
37	1	20.769.000	Gasket D.19.2/11.5 x 2.5
38	1	02.445.000	Pressure Gauge Ø100 INOX 0-6 Bar
39	1	02.470.000	Pressure Gauge Guard
40	10	F0.023.035I	Stainless Steel Clip
41	1	00.493.000	1" 1/4 Fly Nut
42	1	24.054.000	Hosetail M-F 1"
43	1	02.274.000	Female Tesse 1"

2.12 LIQUID FLOW PATH

<u>REF.</u>	<u>QTY.</u>	<u>PART NO.</u>	<u>DESCRIPTION</u>
44	1	00.045.012	1" 1/4 M - 1" M Reducer Nipple
45	1	02.293.000	1" M - 3/4" M Reducer Nipple
46	2	00.058.028	Straight Hose R.H. D.30
47	4	OR.000.508	30 x 3 O-Ring Gasket
48	1	00.055.034	Nipple 1" / 1" GAS
49	1	21.058.300	Three Ways Valve
50	1	21.182.000	Packing 1" M
51	1	21.183.000	Cap Stop
52	1	RP.008.024	Washer D.8 x 24
53	1	TE.008.016T	Screw TE M8 x 16
54	2	00.055.046	Curved Union With R.H. D.17
55	1	02.030.010	Gasket
56	1	02.182.000	Female 3/4" Cap
57	2	FC.023.5.025	Hose Clamp 23.5 - 25
58	2	02.349.000	17 x 23 x 3 Flat Gasket
59	2	02.403.000	Straight Hose R.H. D.25 - 1"
60	3	00.055.021	Straight Hose R.H. D.25
61	1	OR.000.134	O-Ring D.25.8 x 3.53
62	1	21.058.100	Three Ways Valve Complete
63	1	20.794.000	Pipe 90° R.H. 25 3/4" GAS F
64	2	24.068.000	D.25 Hosetail
65	As Req'd	20.852.000	Hose D.30 x 41 L=900 (Per Foot)
66	As Req'd	20.852.000	Hose D.30 x 41 L=1540 (Per Foot)
67	As Req'd	20.809.000	Hose D.25 L=210 (Per Foot)
68	As Req'd	20.809.000	Hose D.25 L=1500 (Per Foot)
69	As Req'd	20.809.000	Hose D.25 L=550 (Per Foot)
70	1	00.422.100	Male Connector RH 30 1" GAS
71	As Req'd	20.770.000	Hose D.25 x 32 L=510 (Per Foot)
72	1	50.355.100	Product Note Support
73	As Req'd	20.852.000	Hose D.30 x 41 L=1600 (Per Foot)
74	As Req'd	20.852.000	Hose D.30 x 41 L=200 (Per Foot)
75	1	21.149.000	Valve 1" F. F.
76	1	OR.002.125	31.47 x 1.78 O-Ring Gasket
77	As Req'd	20.809.000	Hose D.25 x 32 L=380 (Per Foot)
78	As Req'd	02.211.000	Hose D.16 L=1100 (Per Foot)
79	As Req'd	02.217.000	Hose D.8 x 13 L=400 (Per Foot)

2.13 PRESSURE REGULATOR & 3 WAY VALVE

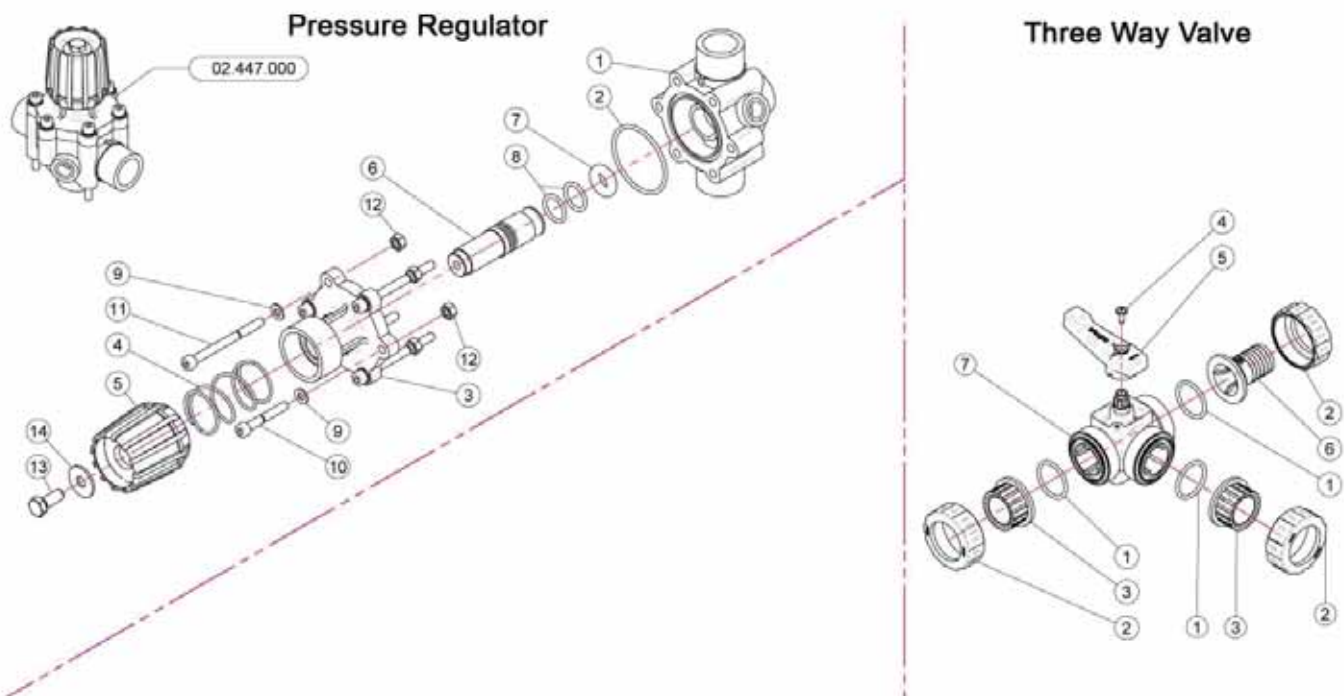

<u>REF.</u>	<u>QTY.</u>	<u>PART NO.</u>	<u>DESCRIPTION</u>
PRESSURE REGULATOR			
1	1	02.447.001	Body For Regulation Valve
2	1	OR.003.193	O-Ring Gasket 48.89 x 2.62
3	1	02.447.009	Upper Flange
4	1	02.447.011	Spring
5	1	02.447.010	Regulation Valve Knob
6	1	02.447.014	Pin
7	1	02.447.005	Special O-Ring For Gate 2447
8	2	OR.003.068	O-Ring Gasket 17.12 x 2.62
9	6	RP.006.000	Washer D.6
10	2	TCE.006.040	Bolt TCE M6 x 40
11	4	TCE.006.070	Bolt TCE M6 x 70
12	6	D0.06.5588G	Nut M6
13	1	TE.008.025I	INOX 8 x 25 Screw
14	1	RP.008.024I	INOX Washer D.8 x 24
3-WAY VALVE			
1	3	OR.004.137	O-Ring D.34.52 x 3.53
2	3	21.058.007	Valve Union Nut
3	2	21.058.006	Valve End Connector
4	1	TA.05.5.016	Self Threaded Screw M5.5 x 16
5	1	21.058.003	Valve Handle
6	1	21.058.009	Rubber Holder D.30
7	1	21.058.110	Body of Three Ways Valve

2.14 SUCTION FILTER ASSEMBLY

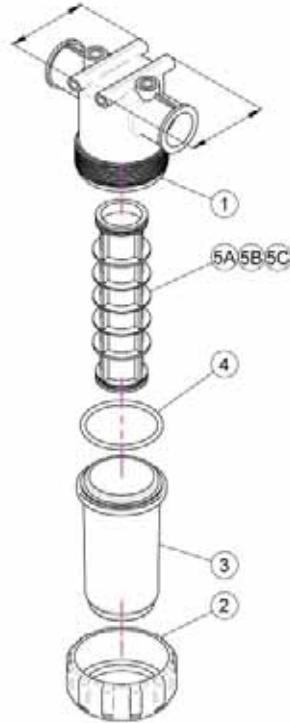

02.450.010

<u>REF.</u>	<u>QTY.</u>	<u>PART NO.</u>	<u>DESCRIPTION</u>
1	1	02.450.001	Line Filter Body
2	1	02.450.003	Ring Nut Filter In Line
3	1	02.450.011	Lid Filter With Unloading
4	1	OR.000.178	O-Ring D.74.63 x 5.33
5A	1	02.450.004C	Cartridge w/ O-Ring 50 Mesh (Blue)
5B	1	02.450.204C	Cartridge w/ O-Ring 80 Mesh (Grey)
5C	1	02.450.104C	Cartridge w/ O-Ring 32 Mesh (White)

2.15 PUMP ASSEMBLY

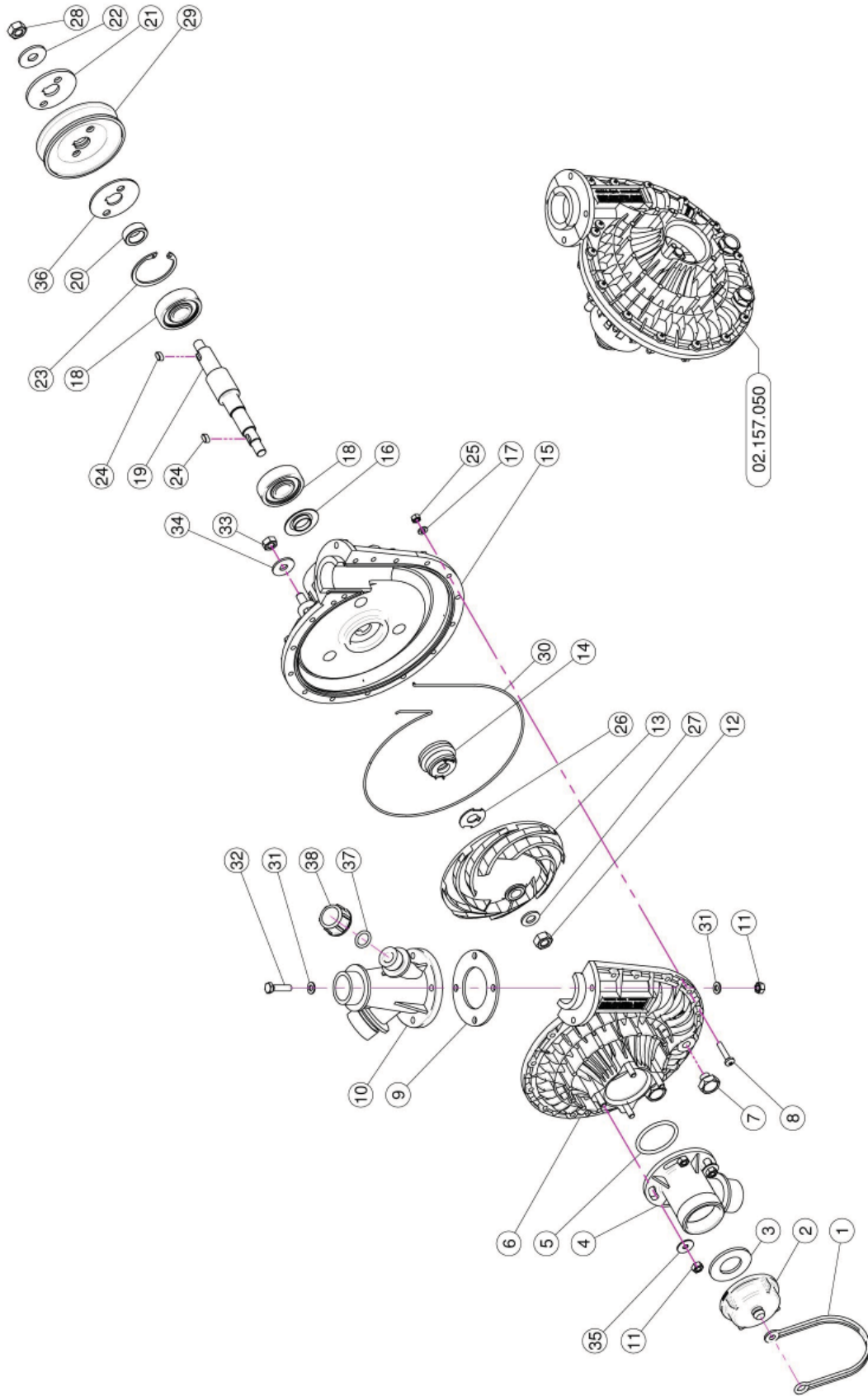

2.15 PUMP ASSEMBLY

<u>REF.</u>	<u>QTY.</u>	<u>PART NO.</u>	<u>DESCRIPTION</u>
1	1	21.183.000	Cap Stop
2	1	02.120.000	Rapid Thread Cap
3	1	02.130.000	24 x 46 x 3 Rubber Gasket
4	1	02.116.000	Suction Fitting
5	1	OR.000.144	O-Ring D.36.69 x 3.53
6	1	02.152.010	Housing
7	2	TM.010.015	M10 x 1.5 Cap
8	17	TC.05.25.85	Cross Slotted Screw M5 x 25
9	1	02.179.000	Rubber Gasket
10	1	02.113.000	Delivery Fitting
11	8	DOT.06.5587	M6 Brass Nut 5587
12	1	DOT.10.5587	M10 Brass Nut
13	1	02.153.000	CD 32 Pump Impeller
14	1	00.085.024CS	Mechanical Seal
15	1	02.151.010	Pump Casing
16	1	20.406.000	Special Cover For Pump
17	17	RP.005.000	Washer D.5
18	2	K6.303.2RS	Roller Bearing
19	1	02.155.010	CD 32 Pump Shaft
20	1	02.722.000	Bush
21	1	02.723.001	Special Washer mm3
22	1	RP.010.030	Washer D.10 x 30 mm
23	1	I0.047.000	Internal D.47 Circlip
24	2	L.05.05.10	5 x 5 x 10 Tang
25	17	DOT.05.5587	M5 Brass Nut (5587)
26	1	02.114.000	INOX Special Washer
27	1	RP.010.00I	Washer D.10 INOX
28	1	D0.10.5588G	M10 6S Big Lead Nut 5588
29	1	02.723.002	Pulley For Pump D.82.5 x 1 3V
30	1	OR.C02.070	R Cord D.2 L=700
31	8	RP.006.000	Washer D.6
32	4	TE.006.025T	Screw TE M6 x 25
33	3	D0.08.5588G	M8 6S Big Lead Nut 5588
34	3	RP.008.024	Washer D.8 x 24
35	3	RP.006.018	Washer D.8 x 18
36	1	02.723.005	Special Washer mm2
37	1	OR.000.117	13.1 x 18.34 x 2.62 O-Ring Gasket
38	1	TF.012.000	Blank Cap 1/2"

2.16 CONTROL VALVE - 910208

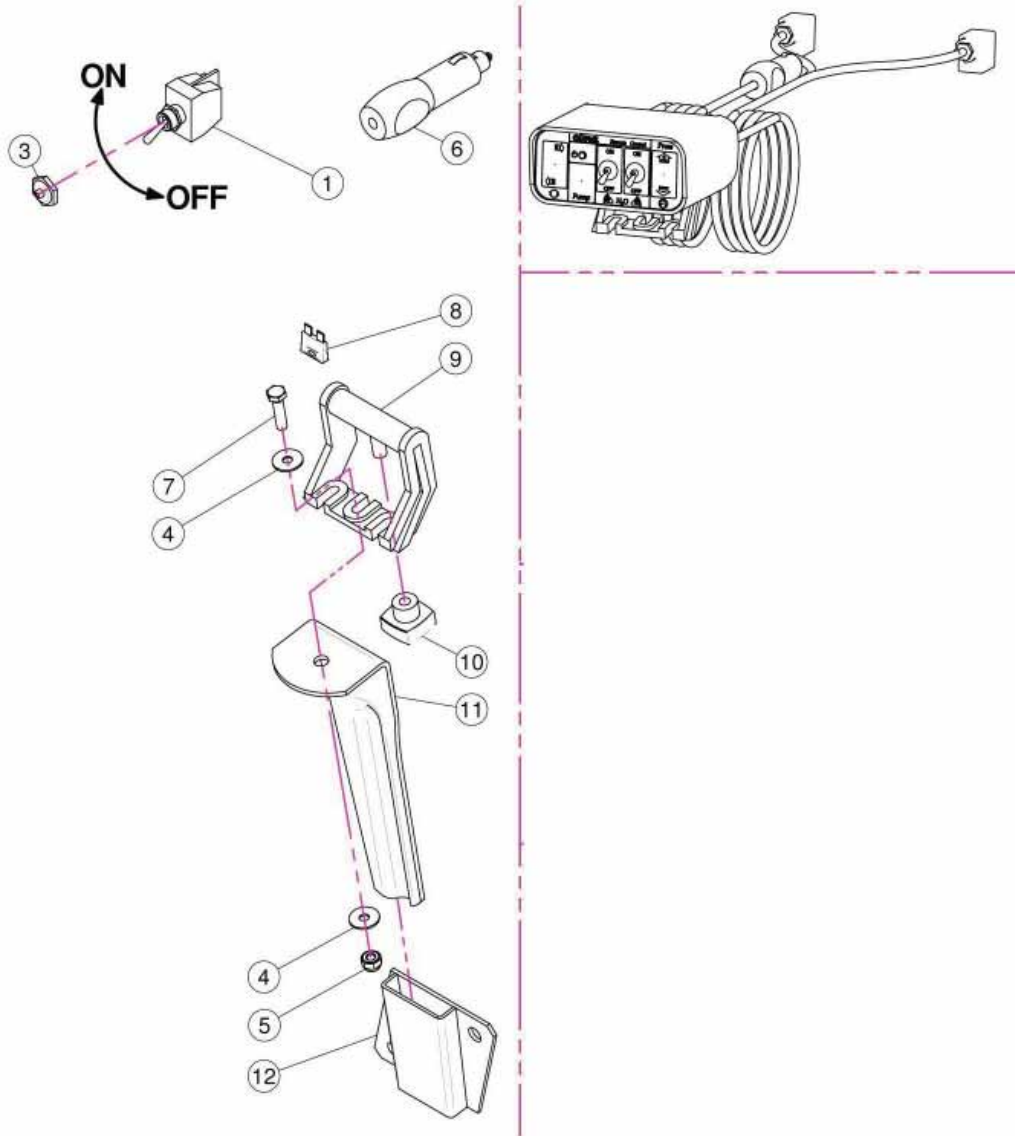

REF.	QTY.	PART NO.	DESCRIPTION
1	2	21.030.005	Switch 2V 2P On-Off 10A
3	2	21.030.007	Switch Cap D.12
4	2	RP.006.018	Washer D.6 x 18
5	1	DA.006.0AG	Self Locking Nut - High M6
6	1	21.030.008	12V Power Jack
7	1	TE.006.025T	Screw TE M6 x 25
8	1	21.030.004	10 Ah Fuse
9	1	21.030.002	Moving Fixing Bracket
10	1	21.030.003	Fixing Knob
11	1	20.111.000	Bracket
12	1	20.107.000	Female Bayonet Support

2.17 ELECTRIC VALVE ASSEMBLY

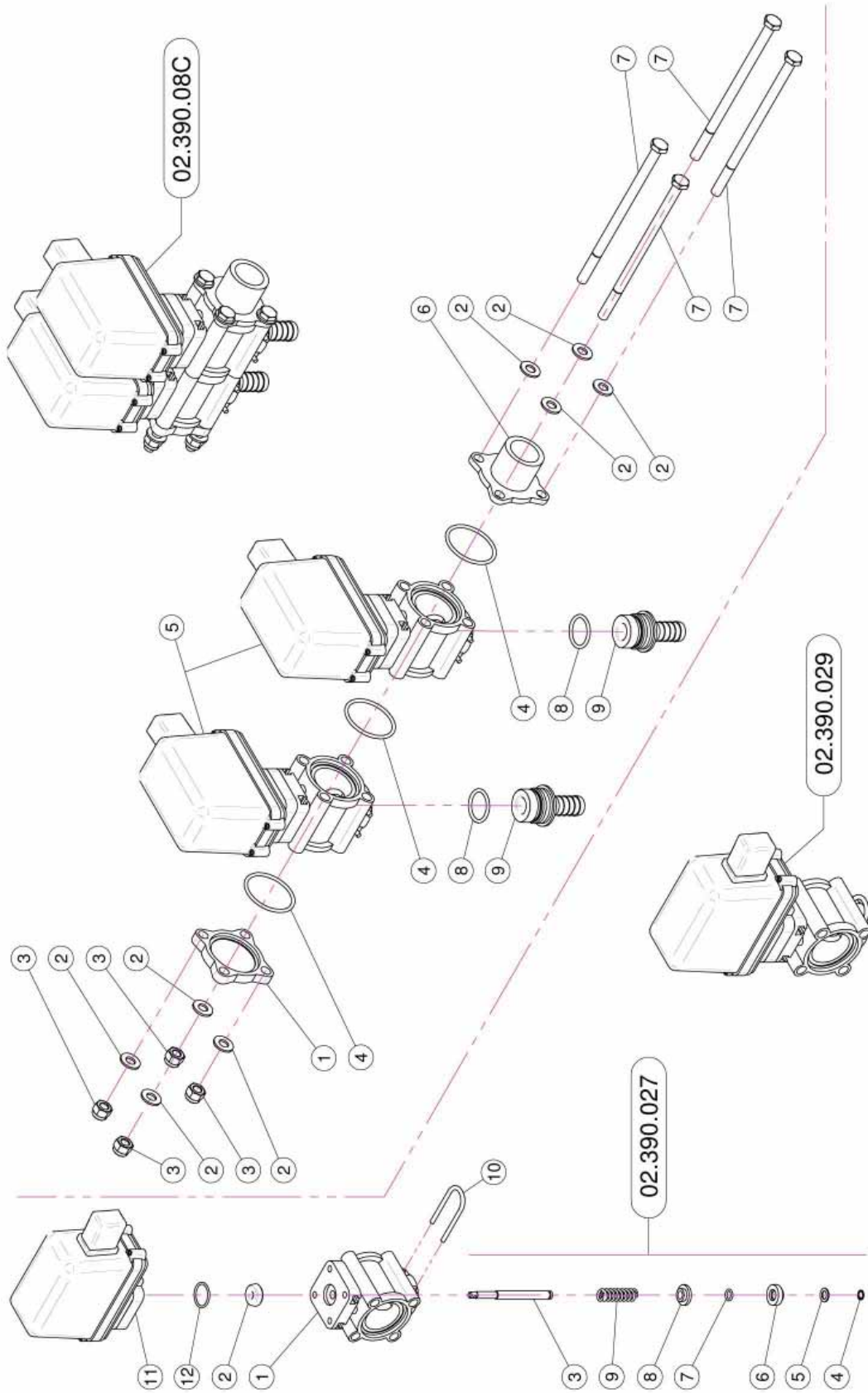

2.17 ELECTRIC VALVE ASSEMBLY

02.390.029

<u>REF.</u>	<u>QTY.</u>	<u>PART NO.</u>	<u>DESCRIPTION</u>
1	1	02.390.007	Valve Body
2	1	02.390.008	Gasket
3	1	02.390.020	Pin
4	1	02.390.013	Stop Ring
5	1	02.390.014	Washer 7.2 x 12 INOX
6	1	02.390.015	Lower Valve
7	1	02.390.016	O-Ring
8	1	02.390.009	Superior Valves
9	1	02.390.011	Spring
10	1	21.130.005	Fork
11	1	02.390.028	Solenoid Valve
12	1	OR.002.075	D.18.77 x 1.78 O-Ring

02.390.08C

1	1	02.390.017	Valve Flange
2	8	RP.008.000	Washer D.8
3	4	DA.008.0AG	Self Locking Nut M8
4	3	OR.003.156	O-Ring Gasket 39.34 x 2.62
5	2	02.390.029	Solenoid Valve
6	1	02.390.018	Connector
7	4	TE.008.150	Screw TE M8 x 150
8	2	OR.000.130	22.22 x 2.62 O-Ring Gasket
9	2	02.406.000	Hosetail D.16

2.18 PUMP & FAN BELTS

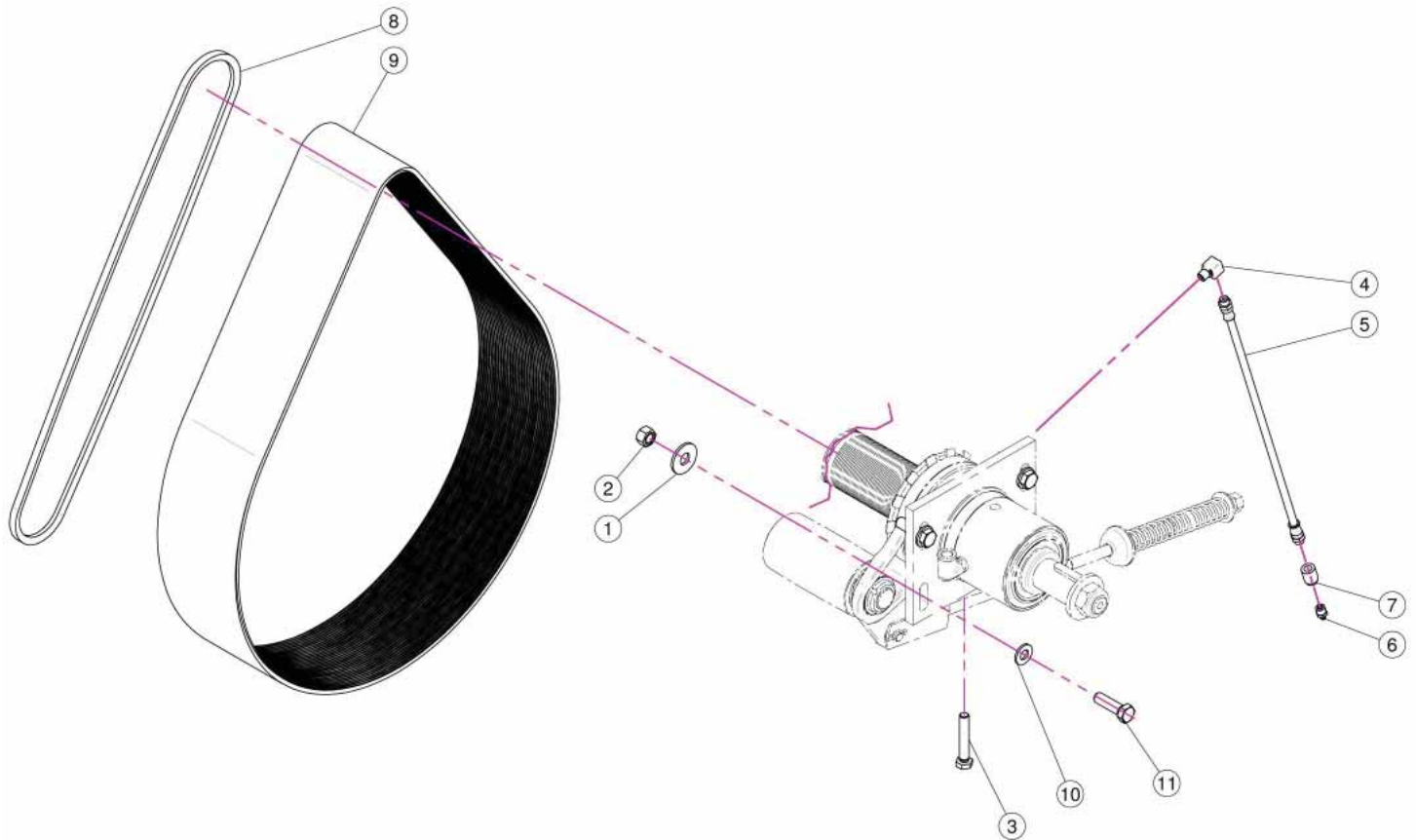

<u>REF.</u>	<u>QTY.</u>	<u>PART NO.</u>	<u>DESCRIPTION</u>
1	4	RP.012.036	Washer D12 x 36
2	4	D0.12.5587G	M12 Nut
3	1	TE.010.060T	Screw TE M10 x 60
4	1	02.736.000	90 G. M10 x 1 Fitting
5	1	02.738.040	Greaser Extension M10 x 1 L=400
6	1	ID.010.001	Grease Nipple
7	1	02.737.000	Accessori
8	2	C0.500.03V	V-Belt
9	1	C0.690.J50	Poly V-Belt
10	4	RP.012.000	Washer D.12
11	4	TE.012.040T	Bolt TE M12 x 40

2.19 AXLE & WHEEL HUBS

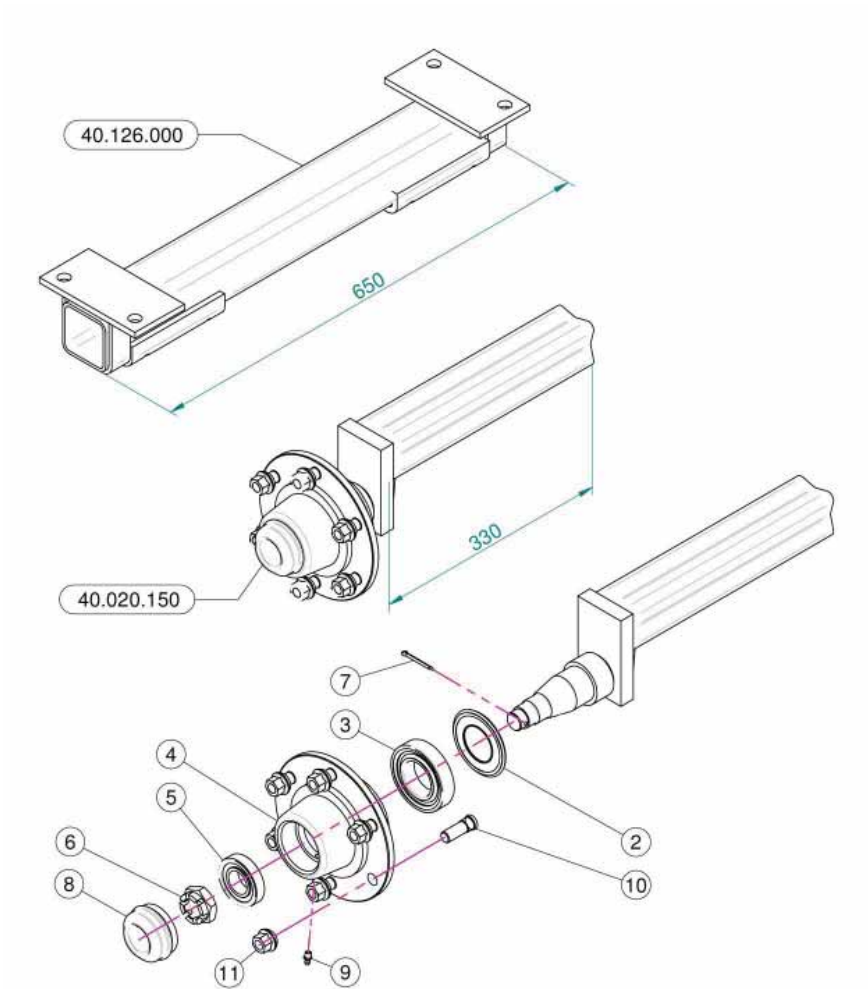

<u>REF.</u>	<u>QTY.</u>	<u>PART NO.</u>	<u>DESCRIPTION</u>
2	1	20.258.000	Oil Cover
3	1	K0.030.209	Bearing
4	1	05.903.001	Six Holes Flange
5	1	K0.030.206	Bearing
6	1	DI.027.5594F	Six Castle Nut M27
7	1	20.259.000	Split Pin
8	1	04.062.001	Cover
9	1	ID.006.001	Greaser
10	6	05.911.001	Stud
11	6	05.911.000	Special Nut

2.20 DRIVESHAFT - AB6105

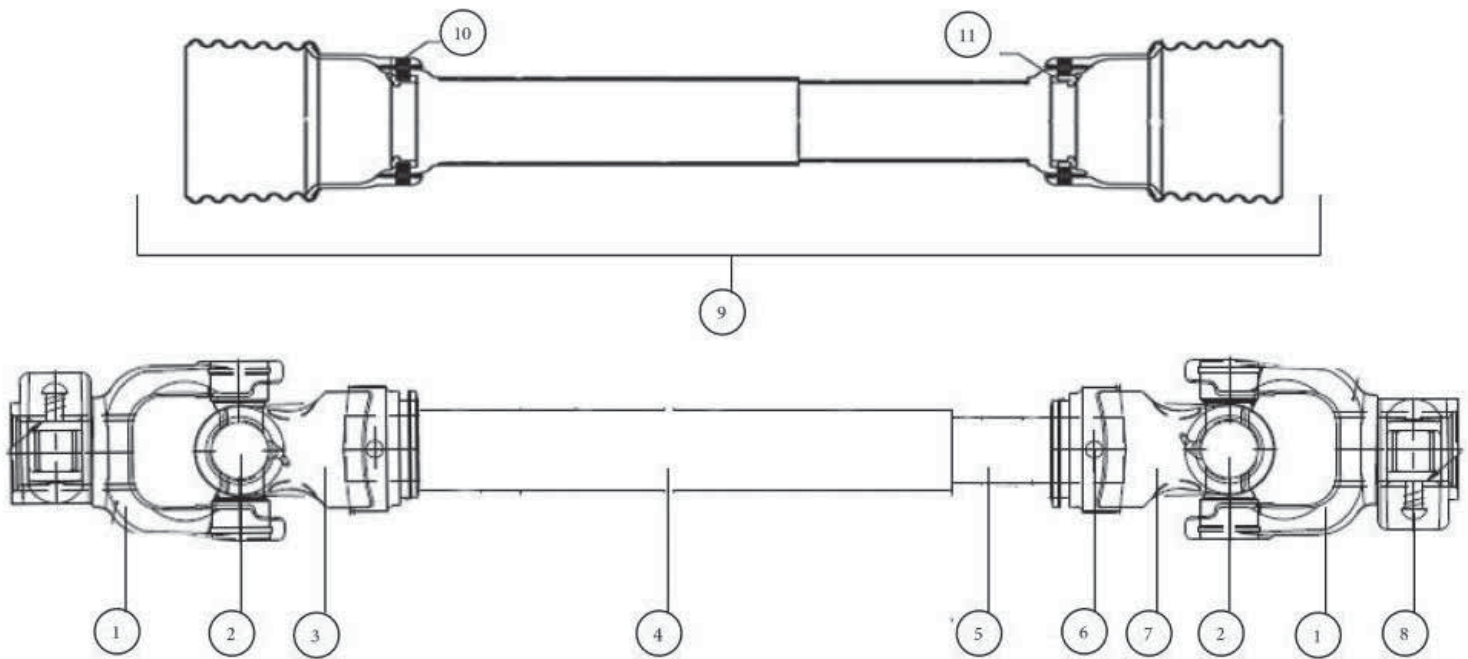

REF.	PART NO.	DESCRIPTION
1	A622138	Quick Release Yoke 1 3/8" x 6 Spline
2	A622	Cross Bearing (2 Required)
3	A6254	Outer Tube Yoke
4	A544	Outer Drive Tube
5	A454	Inner Drive Tube
6	A1065	Poll Pin (2 Required)
7	A6245	Inner Tube Yoke
8	AB121	Quick Release Button
9	AS30090	Safety Guard Complete With Bearing
10	AS301	Release Lever Kit
11	ASB3	Bearing Kit

3 LIMITED WARRANTY



GEARMORE, INC., warrants each new Gearmore product to be free from defects in material and workmanship for a period of twelve (12) months from date of purchase to the original purchaser. This warranty shall not apply to implements or parts that have been subject to misuse, negligence, accident, or that have been altered in any way.

Our obligation shall be limited to repairing or replacement of any part, provided that such part is returned within thirty (30) days from date of failure to Gearmore through the dealer from whom the purchase was made, transportation charges prepaid.

This warranty shall not be interpreted to render us liable for injury or damages of any kind or nature, direct, consequential or contingent, to person or property. This warranty does not extend to loss of crops, loss because of delay in harvesting or any other expenses, for any other reasons.

Gearmore in no way warrants engines, tires, or other trade accessories, since these items are warranted separately by these respective manufacturers.

Gearmore reserves the right to make improvements in design or changes in specification at any time, without incurring any obligations to owners or units previously sold.

Please be advised that all warranty work done by your dealer must be approved by Gearmore before work begins.

GEARMORE, INC.
13477 Benson Ave.
Chino, CA 91710

Always refer to and heed machine operating warning decals on machine.

*To validate the warranty on this product, please log-in to our website - www.gearmore.com.
You will find "warranty registration" listed at the top of our homepage.*