



ROTARY TILLER

**Operation, Service
& Parts Manual For
“H” Series**

November 1996 (Rev. 4-05)

TABLE OF CONTENTS

Preparation	1
Assembly Instructions	2
Connection to Tractor	3
General Maintenance	4
Setting Tiller Rotorshaft R.P.M.	5
Safety Information	6
Safety Decals	7-9
Troubleshooting	10
Replacing Clutch Linings	11
Tiller Assembly	12-15
Gearbox Assembly	16-17
Driveline Assembly	18
Limited Warranty	19

Date of Purchase: _____

Model Number: _____

Serial Number _____

PREPARATION

WARNING

To prevent possible personal injury or death during assembly, installation, operation, adjustment, or removal of implement, **DO NOT** wear loose clothing, always wear gloves and safety glasses or face shield. **Keep other persons a minimum of twenty-five (25) feet away from any unit under power.**



READ THIS BEFORE OPERATING TILLER

TRAINING

Know your controls. Read this operator's manual and the manual provided with your tractor. Learn how to stop the tractor engine and tiller quickly, in case of an emergency. **DO NOT** allow children to operate machine, or adults to operate it without proper instructions.

PREPARATION

- Clear area of debris.
- Never permit any person other than the operator to ride on board the tractor at any time.
- **DO NOT** allow riders on tiller at any time.
- Operate only in daylight or good artificial light.
- Ensure all safety shielding is properly installed.
- *Always* wear relatively tight and belted clothing when operating tiller. Loose clothing should not be worn, as it could get caught in the moving parts or controls.

ASSEMBLY INSTRUCTIONS

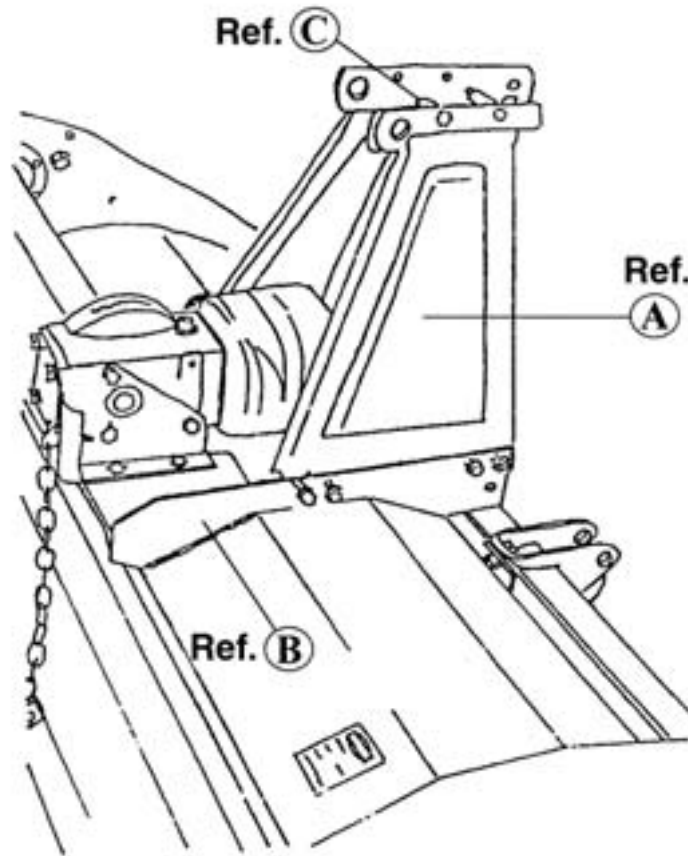

1. With Tiller on bottom pallet, install a-frame mast (Ref. A). *Note:* The mast mounts on the inside of the rails (Ref. B).
2. Install spacer (Ref. C) between the two a-frame masts using supplied bolt and nut.
3. Tighten all bolts and nuts.
4. Install PTO driveline to tiller gearbox. *Note:* The slip clutch assembly goes to the tiller gearbox.
5. Check oil in gearbox and chain case (140 SAE Lube).

CONNECTION TO TRACTOR

Your Gearmore Rotary Tiller can be attached to tractors having a 3-point hitch with category "II" length arms and category "II" hitch balls.

1. Attach the lower link arms of the tractor to the lower attaching brackets of the tiller by inserting the pins.
2. Attach the top link of the 3-point hitch to the tiller. Next, tighten the lower link arm check chains to prevent any horizontal movement of the tiller, which could cause damage during operation. Adjust the unit so the drive shaft is parallel to the ground in the working position. Adjust the tractor lift linkage or the hydraulic lever lifting stops to prevent the tiller being lifted more than 6" from the ground. This will avoid any damage to the universal joints.
3. Attach the drive shaft, first to the tiller input shaft and then to the PTO of the tractor. Make sure the yokes are locked on to the tractor and tiller shaft.

SLIP CLUTCH DRIVE SHAFT:

This tiller has a drive shaft with a slip clutch, which has been calibrated for a certain overload. To adjust the clutch, tighten or loosen bolts equally. Don't over-tighten or clutch will lock and not slip under stress, which could cause damage during operation. The clutch assembly should get warm under normal operation. If the clutch gets extremely hot, this is a sign of slippage. If the machine sits for an extended period of time with no usage, the bolts should be loosened and the PTO engaged. This will allow the clutch discs to become free again. After a few seconds, shut-off the tractor and retighten bolts equally. Recheck clutch assembly for temperature after using in tilling application. If it is too hot, the bolts need tightening. If it is too cool, loosen bolts.

SET SIDE SKIDS FOR WORKING DEPTH:

To regulate working depth, loosen the nuts of the skids and adjust them to the desired position. Set skids equally on both sides.

TRANSMISSION CHAIN TENSION:

Your Gearmore Rotary Tiller has an automatic chain tensioner, so no adjustment is necessary.

TINES:

When the complete set of tines has to be replaced, it is advisable to replace one at a time to insure that the new tines are mounted in the same position as the old ones. It is important to fit the bolts with the heads to the side of the tine and the nuts and washers to the side of the flange. It is also recommended to replace all washers with new ones at the time of tine replacement.

GENERAL MAINTENANCE

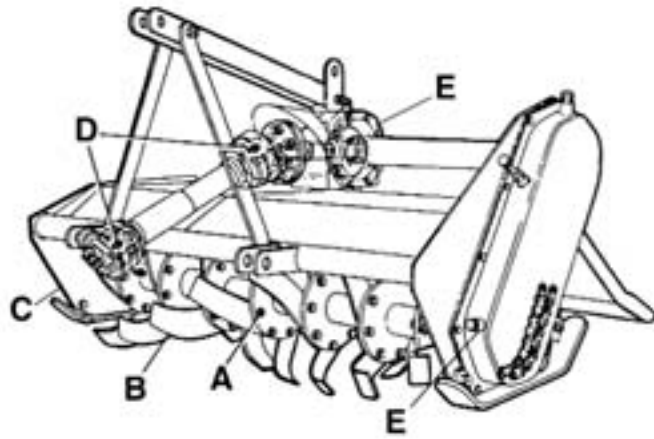

Carefully follow all instructions as stated in this operator's manual, this includes safety, assembly, operation, lubrication, and maintenance of the tiller.

1. Check lubrication - See Lubrication Section.
2. Check bolts and nuts for tightness (Ref. A).
3. Check tiller daily for loose, worn or broken tines (Ref. B).
4. Replace, **immediately**, any damaged or worn parts.

LUBRICATION

GEARBOX & CHAIN CASE:

Fill gearbox and chain case to level plug (Ref. E) with gear oil. Use SAE #140 multi-gear lubricant or equivalent. Gear oil should be checked weekly and changed *every 400 hours* of use.

ROTOR SHAFT:

Lubricate rotor spindle (Ref. C) *daily*. **NOTE:** Grease zerk located on the side of the tiller.

DRIVE SHAFT:

Grease both cross and shield bearings (Ref. D). After that grease *every 8 hours* of use. It is also necessary, from time to time, to untelescope the drive shaft to clean and re-grease tubing.

NOTE: Driveshafts with a slip clutch do not have a grease zerk on the clutch assembly.

WARNING - DO NOT OPERATE TILLER UNLESS ALL SHIELDS ARE IN PLACE

SETTING TILLER ROTOR SHAFT R.P.M.

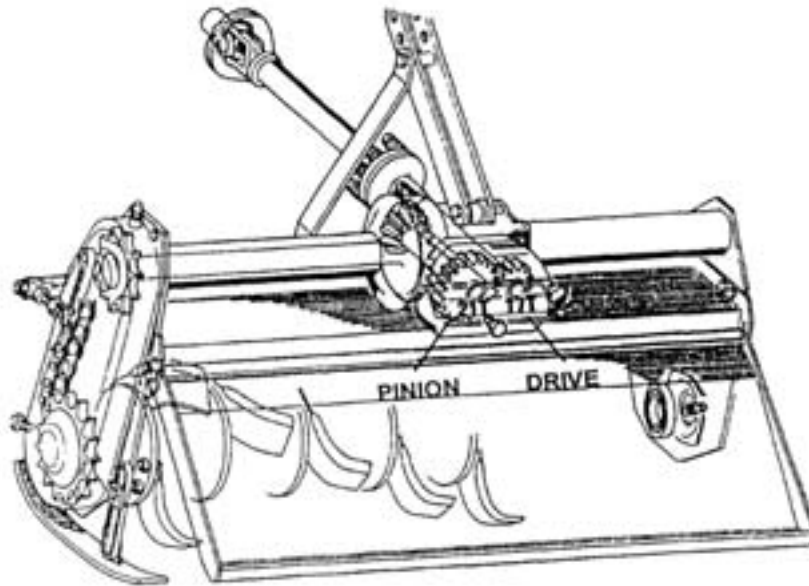

GEAR SETTING	PINION GEAR	DRIVE GEAR	540 R.P.M. SPEED	1000 R.P.M. SPEED
1	23T	17T	176 R.P.M.	325 R.P.M.
2	21T	19T	216 R.P.M.	400 R.P.M.
3	19T	21T	265 R.P.M.	
4	17T	23T	323 R.P.M.	

1. Make sure the tiller is sitting on the ground, the tractor engine off, and parking brake set. The tiller should be level or tilted slightly forward to minimize oil dripping out the back.
2. Remove cover from the back side of gearbox.
3. Verify the rotor R.P.M. you want to achieve and set the gear ration with the corresponding gears on the chart.

EXAMPLE: You want to achieve 176 R.P.M., then put the 23 tooth gear on the *pinion* side and 17 tooth gear on the *drive* side (see above picture). Run tractor P.T.O. at the 540 R.P.M. setting.

4. Install the spare gears to inside of cover and replace cover on gearbox.
5. Torque bolts on cover to 2 ft/lbs (24 inch pounds) and check the oil level of gearbox.

SAFETY INFORMATION

OPERATIONAL SAFETY:

- Guards and safety shields are for your protection. **DO NOT** operate equipment unless they are in place.
- Always operate tractor PTO (power take-off) at recommended RPM (revolutions per minute).
- Disengage tractor PTO and shift into neutral before attempting to start engine.
- Read and observe all safety decals on the tractor and tiller. (*See pages 7 - 9*)
- NEVER** allow anyone within 25' of machine while it is in operation.
- Do not stop or start suddenly when going uphill or downhill. Avoid operation on steep slopes.
- Be alert for holes in terrain and other hidden hazards. Always drive slowly over rough ground.
- Reduce speed on slopes and in sharp turns to prevent tipping or loss of control. Be careful when changing direction on slopes.
- Stop tiller and tractor immediately upon striking an obstruction. Turn off engine, inspect tiller, and repair any damage before resuming operation.
- Disengage power to tiller and stop engine before dismounting from tractor, before making any repairs or adjustments, transporting, or unclogging tiller.
- Take all possible precautions when leaving tractor unattended: Disengage PTO, lower tiller, shift into neutral, set parking brake, stop engine, and remove key from ignition.
- Front tractor weights or front tire ballast should be used to enhance front end stability on small tractors.
- Check to make sure PTO is properly connected and that the driveline is correct to prevent bottoming out or pulling apart during the full lift range of the hitch.
- Never work under tiller without safety blocks.
- This implement is designed for a one-man operation. It is the responsibility of the tractor operator to see that no one is in the proximity of the implement when it is started. **DO NOT** operate the implement with another person within 25' of the implement or PTO drive.

TILLER SAFETY DECALS

1. Keep all safety decals and signs clean and legible at all times.
2. Replace safety decals and signs that are missing or have become illegible. (Contact Gearmore at 909/548-4848 for *free* replacement safety decals.)

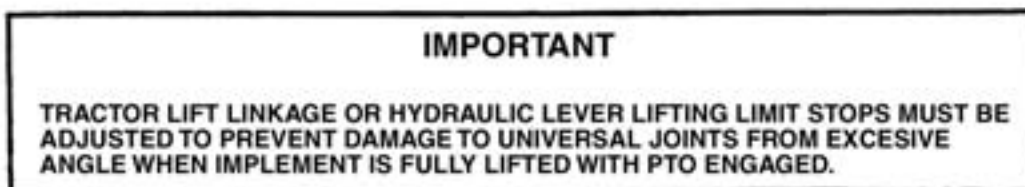
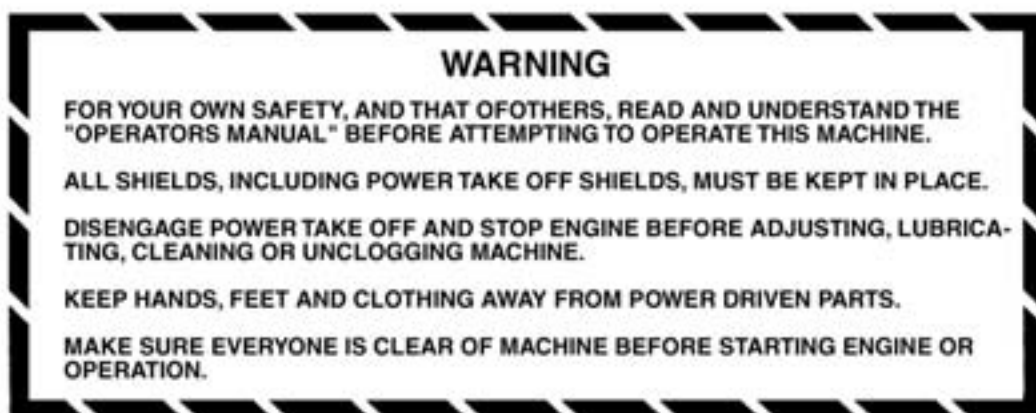

TILLER SAFETY DECALS



DANGER: Hands and feet could be severely injured. Keep away from rotating parts.



DANGER: Do not stay behind the machine as it could roll over you.



DANGER: Never get near to the PTO shaft while it is in operation. ACCIDENTAL CONTACT COULD CAUSE DEATH.

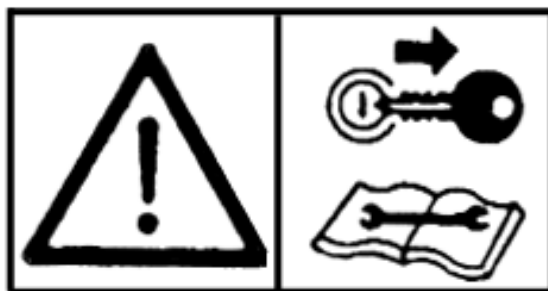

Stop both the machine and the tractor before performing any service.

TILLER SAFETY DECALS



DANGER: The machine could throw heavy or sharp objects. Keep at a safe distance from the machine.



Please carefully read and understand the operating instructions before using the machine.

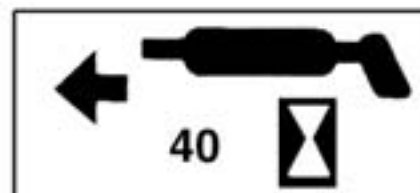

TROUBLESHOOTING CHART

PROBLEM	CAUSE	SOLUTION
Excessive vibration	Drive shaft damaged	Replace worn drive shaft
	Tines broken off	Replace damaged tines
	Bent rotor shaft	Replace rotor shaft
Rotor shaft does not turn	PTO Clutch slipping	Check slip clutch adjustment
		Replace clutch discs
Tilling deeper on one side	Tractor lower lift arm out of adjustment	Adjust lift arm
	Tiller depth skid not properly adjusted	Adjust skids to level depth
Tiller bouncing	Trying to go too deep on first pass	Raise tiller so tilling 3" deep
	Tractor in too high a gear	Tiller runs smoother in first or second gear
Leaving tire tracks	Tires set out too wide	Set in tractor tires
	Tractor too large	Offset tiller to cover right tire tracks
PTO will not untelescope	Improper lubrication	Separate and grease both halves
	PTO twisted	Replace twisted parts
	Shields damaged	Replace shields

REPLACING CLUTCH LININGS

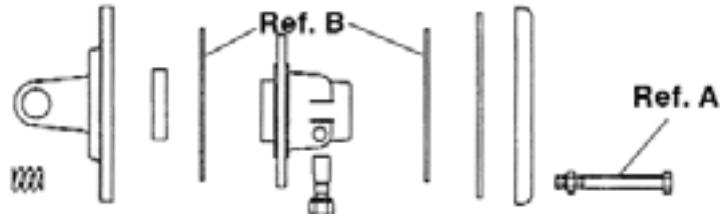

1. Mount clutch assembly in vise.
2. Remove all bolts and nuts (Ref. A).
3. Disassemble all components.
4. Check the condition of all parts, friction plates especially.
5. Replace clutch linings (Ref. B).
6. Reassemble the components, install spring with their corresponding bolts and nuts.
7. Tighten nuts following an alternating cross pattern until reaching a height of 27 mm (1.063").
8. Check that the height is the same for all springs.
9. Reinstall driveline, making sure all shields are in place.

PROTECTION GUARDS

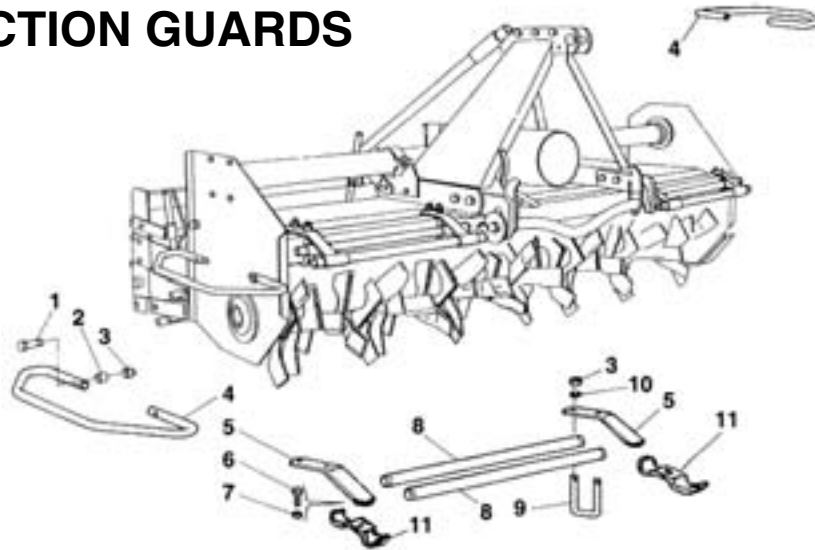

<u>REF#</u>	<u>QTY.</u>	<u>PART NO.</u>	<u>DESCRIPTION</u>
1	4	80.Z.01.069	Bolt M10 x 55
2	4	72.80.0034	Spacer
3	8	80.Z.11.012	Locknut M10
4	2	76.90.0001	Side Protection Bar
5	4	78.48.0120	Front Support Bracket
6	4	80.Z.03.137	Bolt M10 x 30
7	4	80.Z.11.012	Locknut M10
8	4	78.94.0011	Front Protection Bar
9	4	72.21.0012	Channel Bolt M10 x 100 x 81
10	8	80.Z.30.010	Flat Washer
11	4	78.44.0016	U-Clamp
12	1	65.15.0022	Complete Guard

"H" TILLER ASSEMBLY

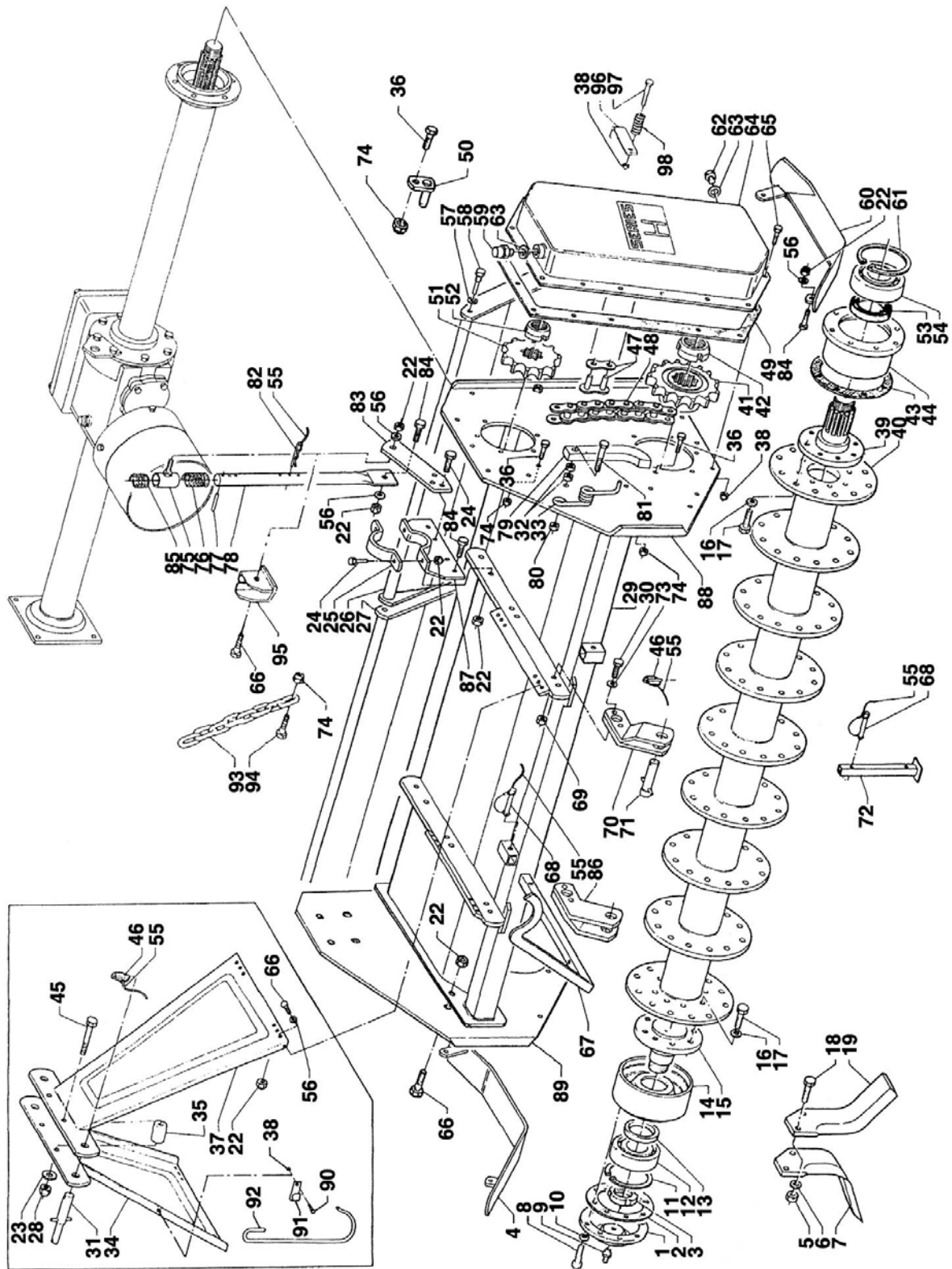

TILLER ASSEMBLY

<u>REF#</u>	<u>QTY.</u>	<u>PART NO.</u>	<u>DESCRIPTION</u>
1	1	72.44.0007	Cover, Rotor Hub
2	1	74.41.0013	Gasket
3	1	80.Z.55.014	Nut M45 x 1.5
4	1	78.16.0009	Skid R.H.
5	See Chart Pg. 15	80.Z.08.111	Nut M14 x 1.5
6	See Chart Pg. 15	80.S.35.114	Washer D.14
7	See Chart Pg. 15	79.66.0009	Tine R.H.
8	6	80.Z.03.139	Bolt M10 x 40
9	1	80.A.61.010	Grease Zerk M8 x 1.25
10	6	80.S.35.110	Washer 10.2 - 18.1 - 2.6
11	1	472110	Circlip I.110
12	1	6310	Bearing 50 - 110 - 27
13	1	65X85X10	Oil Seal 65 - 85 - 10
14	1	78.48.0007	Support, Rotor
15	1	75.92.0003	Hub, Rotor
16	16	80.S.35.112	Washer 12.2 - 21.1 - 3.2
17	16	80.Z.00.021	Bolt M12 x 1.25 x 30
18	See Chart Pg. 15	80.Z.00.033	Bolt M14 x 1.5 x 40
19	See Chart Pg. 15	79.66.0010	Tine L.H.
22	40	80.Z.11.015	Lock Nut M12
23	3	80.Z.30.016	Washer 17 - 30 - 3
24	As Req'd	80.R.01.087	Bolt M12 x 45
25	2	72.21.0005	Clamp
26	1	72.30.0032	Tailboard L.H. H205
26	1	72.30.0034	Tailboard L.H. H230
26	1	72.30.0036	Tailboard L.H. H250
26	1	72.30.0023	Tailboard H165
26	1	72.30.0024	Tailboard H185
26	1	72.30.0112	Tailboard H165 Roller Version
26	1	72.30.0113	Tailboard H185 Roller Version
26	1	72.30.0121	Tailboard L.H. H205 Roller Version
26	1	72.30.0123	Tailboard L.H. H230 Roller Version
26	1	72.30.0125	Tailboard L.H. H250 Roller Version
27	1	72.30.0033	Tailboard R.H. H230
27	1	72.30.0035	Tailboard R.H. H250
27	1	72.30.0055	Tailboard R.H. H205
27	1	72.30.0120	Tailboard R.H. H205 Roller Version
27	1	72.30.0122	Tailboard R.H. H230 Roller Version
27	1	72.30.0124	Tailboard R.H. H250 Roller Version
28	3	80.Z.11.018	Locknut M16 x 1.5
29	1	78.60.0079	Frame H165 (Before s/n 0779)
29	1	78.60.0080	Frame H185 (Before s/n 0779)
29	1	78.60.0031	Frame H205 (Before s/n 0779)
29	1	78.60.0032	Frame H230 (Before s/n 0779)
29	1	78.60.0033	Frame H250 (Before s/n 0779)

TILLER ASSEMBLY

<u>REF#</u>	<u>QTY.</u>	<u>PART NO.</u>	<u>DESCRIPTION</u>
29	1	78.60.0082	Frame H165 (After s/n 0780)
29	1	78.60.0083	Frame H185 (After s/n 0780)
29	1	78.60.0073	Frame H185
29	1	78.60.0084	Frame H205 (After s/n 0780)
29	1	78.60.0085	Frame H230 (After s/n 0780)
29	1	78.60.0086	Frame H250 (After s/n 0780)
30	4	80.Z.02.171	Bolt M20 x 1.5 x 65
31	1	76.65.0015	Pin
32	3	80.S.02.011	Nut M14
33	1	75.85.0005	Spring
34	1	73.68.0006	A-frame Mast R.H.
35	3	72.80.0015	Spacer
36	11	80.Z.03.136	Bolt M10 x 25
37	1	73.68.0007	A-frame Mast L.H.
38	18	80.Z.11.009	Nut M8
39	1	75.92.0004	Hub, Rotor
40	1	77.85.0015	Rotor Shaft H165
40	1	77.85.0016	Rotor Shaft H185
40	1	77.85.0017	Rotor Shaft H205
40	1	77.85.0018	Rotor Shaft H230
40	1	77.85.0019	Rotor Shaft H250
41	1	76.75.0027	Lower Sprocket Z12
42	1	80.Z.55.015	Nut M50 x 1.5
43	1	74.41.0010	Gasket
44	1	78.48.0008	Support, Rotor
45	3	80.Z.02.132	Bolt M16 x 1.5 x 100
46	3	80.S.77.015	Click Pin D.10
47	1	80.A.31.940	Master Link ASA 140
48	1	80.A.31.028	Chain ASA 140, 32 links
49	1	74.41.0005	Gasket
50	2	76.65.0024	Pin, Tailboard Mount (After s/n 0780)
51	1	76.65.0026	Upper Sprocket Z11
52	1	80.Z.56.013	Nut M40 x 1.5
53	1	75X95X12	Oil Seal 75 x 95 x 12
54	1	6312	Bearing 60 - 130 - 31
55	4	80.P.05.001	Tie, Rubber 6 x 40
56	14	80.Z.30.012	Washer 13 - 24 - 2.5
57	As Req'd	80.S.35.118	Washer 18.2 - 29.4 - 4 (Before s/n 0779)
58	As Req'd	76.65.0009	Pin, Tailboard (Before s/n 0779)
59	1	80.F.90.116	Breather Plug
60	1	78.16.0006	Skid L.H.
61	1	80.S.71.130	Circlip I.130
62	1	80.F.90.553	Plug 1/2"
63	2	80.S.38.232	Washer 1/2" 21.5 - 27 - 1.5
64	1	72.14.0010	Cover, Chain Case
65	16	80.R.03.112	Bolt M8 x 25
66	As Req'd	80.Z.03.159	Bolt M12 x 30

TILLER ASSEMBLY

REF#	QTY.	PART NO.	DESCRIPTION
67	1	78.48.0114	Support PTO
68	1	80.S.77.021	Pin D.10 x 70
69	4	80.Z.11.022	Nut M20 x 1.5
70	1	71.46.0013	Lift Bracket L.H.
71	2	76.65.0004	Lift Pin
72	1	76.74.0002	Stand (Optional)
73	4	80.Z.30.020	Washer 21 - 37 - 3
74	As Req'd	80.Z.11.012	Nut M10
75	As Req'd	78.48.0113	Support Tube (Before s/n 09322)
76	As Req'd	75.85.0006	Spring (Before s/n 09322)
77	As Req'd	80.Z.62.252	Roll Pin M6 x 40 (Before s/n 09322)
78	As Req'd	71.42.0014	Support Tube (Before s/n 09322)
79	1	78.63.0003	Tension Arm
80	1	80.Z.11.017	Nut M14
81	1	80.R.03.192	Bolt M14 x 80
82	As Req'd	80.Z.75.506	Clip (Before s/n 09322)
83	As Req'd	78.44.0060	Support Tube Bracket
84	10	80.Z.03.160	Bolt M12 x 35
85	As Req'd	75.85.0007	Spring (Before s/n 09322)
86	1	71.46.0011	Lift Bracket R.H.
87	2	78.48.0101	Support
88	1	73.68.0056	Side Plate L.H. (After s/n 0780)
89	1	73.68.0057	Side Plate R.H. (After s/n 0780)
90	1	80.Z.03.108	Bolt M8 x 16
91	1	73.58.0002	Lock Clip PTO Shaft Holder
92	1	74.14.0002	PTO Shaft Holder
93	As Req'd	72.20.0005	Chain, Tailboard
94	As Req'd	80.Z.03.138	Bolt M10 x 35
95	1	78.48.0108	Chain Support R.H.
95	1	78.48.0123	Chain Support L.H. (For H205, H230, & H250)
96	1	73.58.0013	Tailboard Lock
97	1	80.Z.01.047	Bolt M8 x 45
98	1	75.85.0022	Spring, Tailboard Lock

TILLER TINE CHART			
MODEL NO.	NUMBER OF TINES		NUMBER OF BOLTS & NUTS
	R.H.	L.H.	
H165	21	21	84
H185	24	24	96
H205	27	27	108
H230	30	30	120
H250	33	33	132

GEARBOX ASSEMBLY

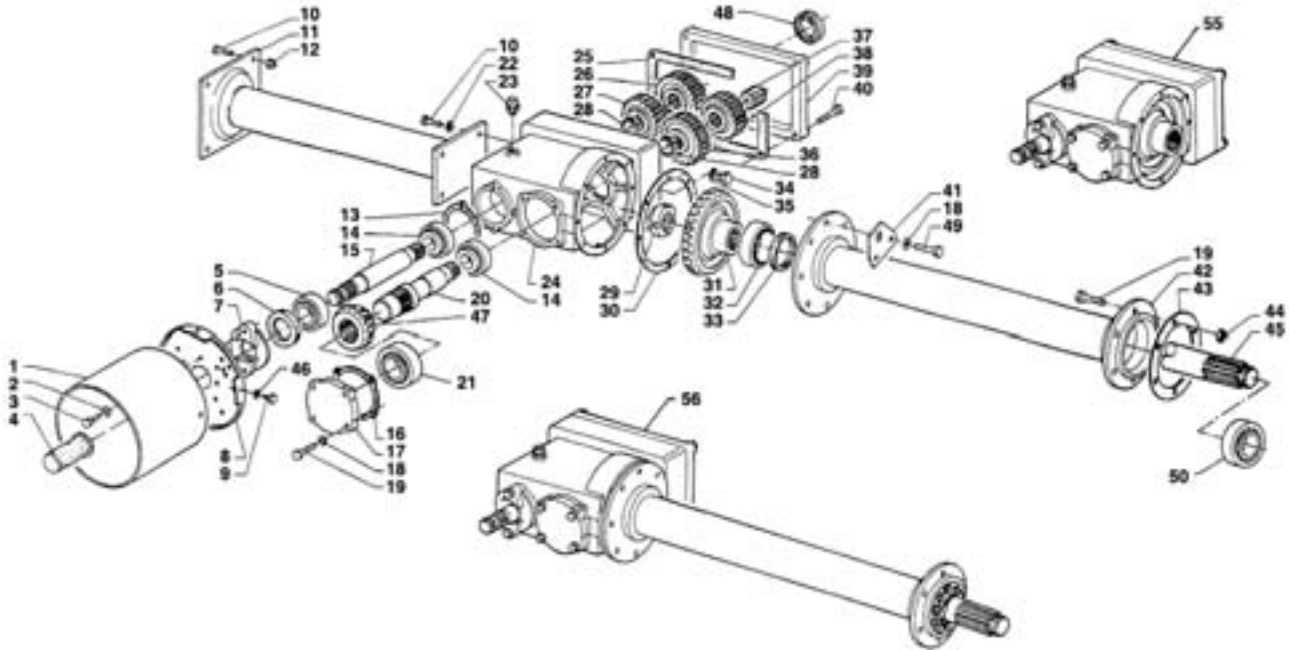

<u>REF#</u>	<u>QTY.</u>	<u>PART NO.</u>	<u>DESCRIPTION</u>
1	1	72.48.0004	Shield, PTO
2	2	80.Z.30.010	Washer 10.5 - 21 - 2
3	2	80.Z.01.067	Bolt M10 x 45
4	1	80.P.09.001	Cover, PTO
5	1	30208	Bearing 40 x 80 x 19.75
6	1	40X52X7	Oil Seal 40 x 52 x 7
7	1	72.44.0015	Cover
8	1	78.48.0111	Bracket, Shield
9	3	80.Z.03.110	Bolt M8 x 20
10	8	80.Z.03.159	Bolt M12 x 30
11	1	76.87.0082	Spacer H165
11	1	76.87.0051	Spacer H185
11	1	76.87.0053	Spacer H205
11	1	76.87.0054	Spacer H230
11	1	76.87.0055	Spacer H250
12	4	80.Z.11.015	Nut M12
13	1	74.41.0041	Gasket 0.1
13	1	74.41.0043	Gasket 0.5
14	2	33208	Bearing 40 - 80 - 32
15	1	71.12.0033	Input Shaft
16	1	74.41.0034	Gasket 0.1
16	1	74.41.0035	Gasket 0.3
17	1	72.44.0016	Cover
18	12	80.S.35.110	Washer 10.2 - 18.2 - 2.6
19	10	80.Z.03.137	Bolt M10 x 30
20	1	71.12.0060	Pinion Shaft
21	1	31310	Bearing 50 - 110 - 29.25

GEARBOX ASSEMBLY

<u>REF#</u>	<u>QTY.</u>	<u>PART NO.</u>	<u>DESCRIPTION</u>
22	4	80.S.35.112	Lockwasher D.12
23	1	80.F.90.116	Breather Plug 1/2"
24	1	78.04.0006	Housing
25	1	74.41.0032	Gasket
26	1	74.80.0018	Gear Z17
27	1	74.80.0014	Gear Z21
28	2	47140	Circlip E40
29	1	80.Z.55.014	Locknut M45 x 1.5
30	1	74.41.0038	Gasket 0.3
30	1	74.41.0039	Gasket 0.5
31	1	72.46.0010	Bevel Gear Z29
32	1	32212	Bearing 60 - 110 - 29.75
33	1	60X80X10	Oil Seal 60 - 80 - 10
34	2	80.F.90.553	Plug 1/2"
35	3	80.S.38.232	Washer 1/2" 21.5 - 27 - 1.5
36	1	74.80.0013	Gear Z19
37	1	75.92.0009	Splined Hub
38	1	74.80.0019	Gear Z23
39	1	72.44.0014	Rear Cover
40	4	80.Z.03.139	Bolt M10 x 40
41	1	78.44.0011	Plate
42	1	76.87.0057	Extension Tube H165 (Before s/n 02070)
42	1	76.87.0066	Extension Tube H185 (Before s/n 02070)
42	1	76.87.0058	Extension Tube H205 (Before s/n 02070)
42	1	76.87.0059	Extension Tube H230 (Before s/n 02070)
42	1	76.87.0060	Extension Tube H250 (Before s/n 02070)
42	1	76.87.0121	Extension Tube H165 (After s/n 02071)
42	1	76.87.0122	Extension Tube H185 (After s/n 02071)
42	1	76.87.0123	Extension Tube H205 (After s/n 02071)
42	1	76.87.0124	Extension Tube H230 (After s/n 02071)
42	1	76.87.0125	Extension Tube H250 (After s/n 02071)
43	1	74.41.0009	Gasket
44	6	80.Z.11.012	Nut M10
45	1	71.12.0050	Extension Shaft H165
45	1	71.12.0056	Extension Shaft H185
45	1	71.12.0051	Extension Shaft H205
45	1	71.12.0052	Extension Shaft H230
45	1	71.12.0053	Extension Shaft H250
46	3	80.Z.30.008	Flat Washer 8.4 - 17 - 1.6
47	1	76.75.0032	Pinion Gear Z14
48	1	80.G.13.403	Oil Seal 35 - 47 - 7
49	8	80.Z.03.136	Bolt M10 x 25
50	1	32011	Bearing 55 - 90 - 23 (Before s/n 02070)
50	1	2211-EC	Bearing 55 - 100 - 25 (After s/n 02071)
55	1	72.39.0012	Complete Gearbox
56	1	72.39.0025	Complete Gearbox w/Ext. Tube H165
56	1	72.39.0026	Complete Gearbox w/Ext. Tube H185
56	1	72.39.0027	Complete Gearbox w/Ext. Tube H205
56	1	72.39.0028	Complete Gearbox w/Ext. Tube H230
56	1	72.39.0029	Complete Gearbox w/Ext. Tube H250

PTO DRIVELINE ASSEMBLY

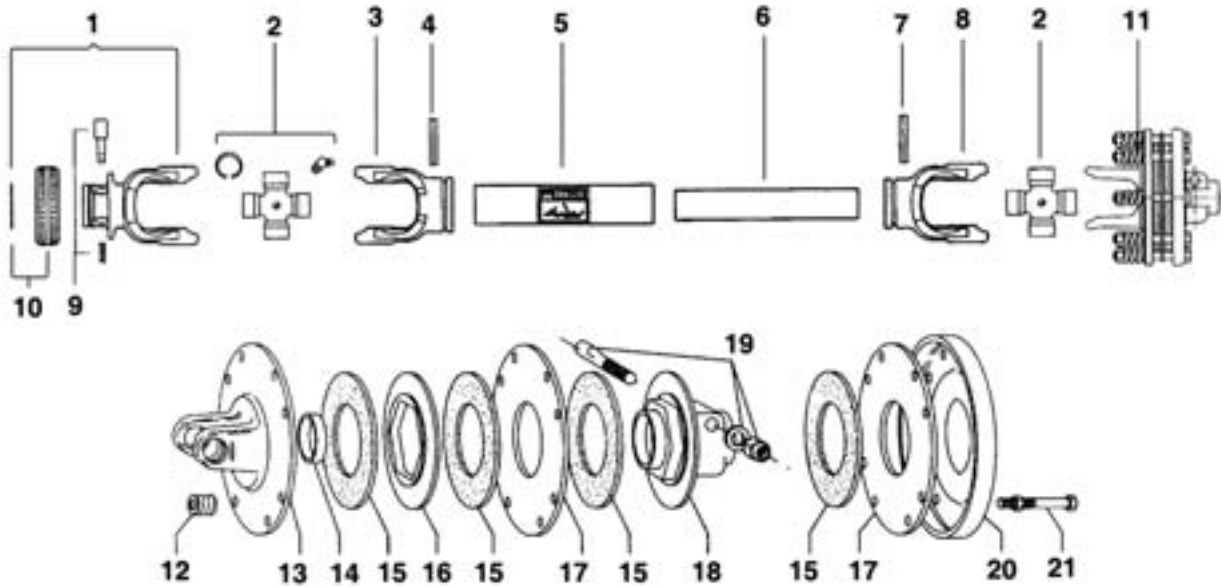

REF#	QTY.	PART NO.	DESCRIPTION
1	1	5720M0376	Yoke 1-3/8" 6-Spline Ball Type Coupler
2	2	41208	Cross Journal Kit #6
3	1	204086860	Yoke, Outer Tube
4	1	341054000	Roll Pin O.T.
5	1	225730860	Tube,Outer Drive
6	1	225690860	Tube, Inner Drive
7	1	341055000	Roll Pin I.T.
8	1	204086861	Yoke, Inner Tube
9	1	403000001	Pin Kit
10	1	240003551	RS Collar Kit
11	1	641460003	Complete Clutch 1 3/8 6-Spline
12	8	351013370	Spring 7mm
13	1	253082302	Flanged Yoke
14	1	258005320	Bushing
15	4	247000061R08	Lining 160mm x 97mm
16	1	275230004	Intermediate Lining Support
17	2	248230002	Pressure Plate 4mm
18	1	515230311	Hub 1 3/8" 6-Spline
19	1	408000060	Tapered Bolt Kit
20	1	248230006	Cover
21	8	432000007	Bolt & Nut
22	1	5F08086F6	Complete Shield (not shown)

LIMITED WARRANTY



GEARMORE, INC., warrants each new Gearmore product to be free from defects in material and workmanship for a period of twelve (12) months from date of purchase to the original purchaser. This warranty shall not apply to implements or parts that have been subject to misuse, negligence, accident, or that have been altered in any way.

Our obligation shall be limited to repairing or replacement of any part, provided that such part is returned within thirty (30) days from date of failure to Gearmore through the dealer from whom the purchase was made, transportation charges prepaid.

This warranty shall not be interpreted to render us liable for injury or damages of any kind or nature, direct, consequential or contingent, to person or property. This warranty does not extend to loss of crops, loss because of delay in harvesting or any other expenses, for any other reasons.

Gearmore in no way warrants engines, tires, or other trade accessories, since these items are warranted separately by these respective manufacturers.

Gearmore reserves the right to make improvements in design or changes in specification at any time, without incurring any obligations to owners or units previously sold.

GEARMORE, INC.
13477 Benson Ave.
Chino, CA 91710

Always refer to and heed machine operating warning decals on machine.

The serial number of this product is stored in our computer database, thus submitting a warranty registration card is not required.