



ECONOMY ARENA ROTARY HARROWS

Operation/Parts Manual

For Models

GRH4E & GRH5E

March 2004 (rev. 3-12)

TABLE OF CONTENTS

SECTION	DESCRIPTION	PAGE
1	Introduction	1
2	Safety.....	2
2.1	General Safety	3
2.2	Equipment Safety Guidelines	4
2.3	Safety Training	5
2.4	Safety Signs	5
2.5	Preparation	6
2.6	Operating Safety.....	7
2.7	Transport Safety	8
2.8	Storage Safety	8
2.9	Maintenance Safety	8
3	Safety Sign Locations.....	9
4	Operation	10
4.1	To the New Operator or Owner	10
4.2	Field Operation	11
4.3	Transporting	14
4.4	Storage	14
5	Assembly.....	15
6	Replacement Parts.....	16
6.1	Parts Diagram.....	16
6.2	Parts List.....	17
7	Specifications	18
7.1	Mechanical	18
7.2	Bolt Torque.....	18
8	Troubleshooting	19
9	Limited Warranty.....	20

1 INTRODUCTION

Congratulations on your choice of Arena-Harrows to complement your harrowing operation. This equipment has been designed and manufactured to meet the needs of a discriminating buyer for the efficient harrowing of horse arenas and racetracks.

Safe, efficient and trouble free operation of your Arena-Harrow requires that you and anyone else who will be operating or maintaining the machine, read and understand the Safety, Operation, Maintenance and Trouble Shooting information contained within the Operator's Manual.

Keep this manual handy for frequent reference and to pass on to new operators or owners. Call your dealer, distributor or the factory if you need assistance, information or additional copies of the manuals.

OPERATOR ORIENTATION - The directions left, right, front and rear, as mentioned throughout this manual, are as seen from the driver's seat and facing in the direction of travel.

2 SAFETY

SAFETY ALERT SYMBOL

This Safety Alert symbol means **ATTENTION! BECOME ALERT! YOUR SAFETY IS INVOLVED!**



The Safety Alert symbol identifies important safety messages on the Arena-Harrow and in the manual. When you see this symbol, be alert to the possibility of personal injury or death. Follow the instructions in the safety message.

Why is SAFETY important to you?

3 Big Reasons

Accidents Disable and Kill

Accidents Cost

Accidents Can Be Avoided

SIGNAL WORDS:

Note the use of the signal words **DANGER**, **WARNING** and **CAUTION** with the safety messages. The appropriate signal word for each message has been selected using the following guide-lines:

DANGER - Indicates an imminently hazardous situation that, if not avoided, will result in death or serious injury. This signal word is to be limited to the most extreme situations typically for machine components which, for functional purposes, cannot be guarded.

WARNING - Indicates a potentially hazardous situation that, if not avoided, could result in death or serious injury, and includes hazards that are exposed when guards are removed. It may also be used to alert against unsafe practices.

CAUTION - Indicates a potentially hazardous situation that, if not avoided, may result in minor or moderate injury. It may also be used to alert against unsafe practices.

If you have any questions not answered in this manual or require additional copies or the manual is damaged, please contact your dealer.

SAFETY

YOU are responsible for the **SAFE** operation and maintenance of your Arena-Harrow. **YOU** must ensure that you and anyone else who is going to operate, maintain or work around the Rotary Harrow be familiar with the operating and maintenance procedures and related **SAFETY** information contained in this manual. This manual will take you step-by-step through your working day and alerts you to all good safety practices that should be adhered to while operating the Harrow.

Remember, **YOU** are the key to safety. Good safety practices not only protect you but also the people around you. Make these practices a working part of your safety program. Be certain that **EVERYONE** operating this equipment is familiar with the recommended operating and maintenance procedures and follows all the safety precautions. Most accidents can be prevented. Do not risk injury or death by ignoring good safety practices.

- Harrow owners must give operating instructions to operators or employees before allowing them to operate the machine, and at least annually thereafter per OSHA (Occupational Safety and Health Administration) regulation 1928.57.
- The most important safety feature on this equipment is a **SAFE** operator. It is the operator's responsibility to read and understand **ALL** Safety and Operating instructions in the manual and to follow these. Most accidents can be avoided.
- A person who has not read and understood all operating and safety instructions is not qualified to operate the machine. An untrained operator exposes himself and bystanders to possible serious injury or death.
- Do not modify the equipment in any way. Unauthorized modification may impair the function and/or safety and could affect the life of the equipment.
- Think **SAFETY!** Work **SAFELY!**

2.1 GENERAL SAFETY

1. Read and understand the Operator's Manual and all safety signs before operating, maintaining, adjusting or unplugging the Harrow.



2. Have a first-aid kit available for use should the need arise and know how to use it.



3. Have a fire extinguisher available for use should the need arise and know how to use it.



4. Wear appropriate protective gear. This list includes but is not limited to:

- A hard hat
- Protective shoes with slip resistant soles
- Protective goggles, glasses or face shield
- Heavy gloves
- Protective clothing



5. Install and secure all guards before starting.
6. Do not allow riders.
7. Wear suitable ear protection for prolonged exposure to excessive noise.
8. Place all controls in neutral, stop tractor engine, set park brake, remove ignition key and wait for all moving parts to stop before servicing, adjusting, repairing or unplugging.
9. Clear the area of people, especially small children, before starting.
10. Review safety related items annually with all personnel who will operating or maintaining the Harrow.



2.2 EQUIPMENT SAFETY GUIDELINES

1. Safety of the operator and bystanders is one of the main concerns in designing and developing a machine. However, every year many accidents occur which could have been avoided by a few seconds of thought and a more careful approach to handling equipment. You, the operator, can avoid many accidents by observing the following precautions in this section. To avoid personal injury or death, study the following precautions and insist those working with you, or for you, follow them.
2. In order to provide a better view, certain photographs or illustrations in this manual may show an assembly with a safety shield removed. However, equipment should never be operated in this condition. Keep all shields in place. If shield removal becomes necessary for repairs, replace the shield prior to use.
3. Replace any safety sign or instruction sign that is not readable or is missing. Location of such safety signs is indicated in this manual.
4. Never use alcoholic beverages or drugs which can hinder alertness or coordination while operating this equipment. Consult your doctor about operating this machine while taking prescription medications.
5. **Under no circumstances should young children be allowed to work with this equipment. Do not allow persons to operate or assemble this unit until they have read this manual and have developed a thorough understanding of the safety precautions and of how it works.** Review the safety instructions with all users annually.
6. This equipment is dangerous to children and persons unfamiliar with its operation. The operator should be a responsible, properly trained and physically able person familiar with farm machinery and trained in this equipment's operations. If the elderly are assisting with farm work, their physical limitations need to be recognized and accommodated.
7. Use a tractor equipped with a Roll Over Protective Structure (ROPS) and a seat belt.
8. Never exceed the limits of a piece of machinery. If its ability to do a job, or to do so safely, is in question - **DON'T TRY IT.**
9. Do not modify the equipment in any way. Unauthorized modification result in serious injury or death and may impair the function and life of the equipment.
10. In addition to the design and configuration of this implement, including Safety Signs and Safety Equipment, hazard control and accident prevention are dependent upon the awareness, concern, prudence, and proper training of personnel involved in the operation, transport, maintenance, and storage of the machine. Refer also to Safety Messages and operation instruction in each of the appropriate sections of the Tractor and machine Manuals. Pay close attention to the Safety Signs affixed to the Tractor and the machine.

2.3 SAFETY TRAINING

1. Safety is a primary concern in the design and manufacture of our products. Unfortunately, our efforts to provide safe equipment can be wiped out by a single careless act of an operator or bystander.
2. In addition to the design and configuration of equipment, hazard control and accident prevention are dependent upon the awareness, concern, prudence and proper training of personnel involved in the operation, transport, maintenance and storage of this equipment.
3. It has been said, "The best safety feature is an informed, careful operator." We ask you to be that kind of an operator. It is the operator's responsibility to read and understand ALL Safety and Operating instructions in the manual and to follow these. Accidents can be avoided.
4. Working with unfamiliar equipment can lead to careless injuries. Read this manual, and the manual for your tractor, before assembly or operating, to acquaint yourself with the machines. If this machine is used by any person other than yourself, or is loaned or rented, it is the machine owner's responsibility to make certain that the operator, prior to operating:
 - a. Reads and understands the operator's manuals.
 - b. Is instructed in safe and proper use.
5. Know your controls and how to stop tractor, engine, and machine quickly in an emergency. Read this manual and the one provided with your tractor.
6. Train all new personnel and review instructions frequently with existing workers. Be certain only a properly trained and physically able person will operate the machinery. A person who has not read and understood all operating and safety instructions is not qualified to operate the machine. An untrained operator exposes himself and bystanders to possible serious injury or death. If the elderly are assisting with farm work, their physical limitations need to be recognized and accommodated.

2.4 SAFETY SIGNS

1. Keep safety signs clean and legible at all times.
2. Replace safety signs that are missing or have become illegible.
3. Replaced parts that displayed a safety sign should also display the current sign.
4. Safety signs are available from your authorized Distributor or Dealer Parts Department or the factory.

How to Install Safety Signs:

- Be sure that the installation area is clean and dry.
- Be sure temperature is above 50°F (10°C).
- Determine exact position before you remove the backing paper. (See Section 3).
- Remove the smallest portion of the split backing paper.
- Align the sign over the specified area and carefully press the small portion with the exposed sticky backing in place.
- Slowly peel back the remaining paper and carefully smooth the remaining portion of the sign in place.
- Small air pockets can be pierced with a pin and smoothed out using the piece of sign backing paper.

2.5 PREPARATION

1. Never operate the tractor and machine until you have read and completely understand this manual, the Tractor Operator's Manual, and each of the Safety Messages found on the safety signs on the tractor and machine.

2. Personal protection equipment including hard hat, safety glasses, safety shoes, and gloves are recommended during assembly, installation, operation, adjustment, maintaining, repairing, removal, or moving the implement. Do not allow long hair, loose fitting clothing or jewelry to be around equipment.



3. **PROLONGED EXPOSURE TO LOUD NOISE MAY CAUSE PERMANENT HEARING LOSS!**

Tractors with or without equipment attached can often be noisy enough to cause permanent, partial hearing loss. We recommend that you wear hearing protection on a full-time basis if the noise in the Operator's position exceeds 80db. Noise over 85db on a long-term basis can cause severe hearing loss. Noise over 90db adjacent to the Operator over a long-term basis may cause permanent, total hearing loss. **NOTE:** Hearing loss from loud noise (from tractors, chain saws, radios, and other such sources close to the ear) is cumulative over a lifetime without hope of natural recovery.



4. Operate the machine only with a tractor equipped with an approved Roll-Over-Protective Structure (ROPS). Always wear your seat belt. Serious injury or even death could result from falling off the tractor ---particularly during a turnover when the operator could be pinned under the ROPS or the tractor.
5. Clear working area of stones, branches or hidden obstacles that might be hooked or snagged, causing injury or damage.
6. Operate only in daylight or good artificial light.
7. Be sure machine is properly mounted, adjusted and in good operating condition.
8. Ensure that all safety shielding and safety signs are properly installed and in good condition.



2.6 OPERATING SAFETY

1. Please remember it is important that you read and heed the safety signs on the Rotary Harrow. Clean or replace all safety signs if they cannot be clearly read and understood. They are there for your safety, as well as the safety of others. The safe use of this machine is strictly up to you, the operator.
2. All things with moving parts are potentially hazardous. There is no substitute for a cautious, safe-minded operator who recognizes potential hazards and follows reasonable safety practices. The manufacturer has designed this Rotary Harrow to be used with all its safety equipment properly attached, to minimize the chance of accidents. Study this manual to make sure you have all safety equipment attached.
3. If a safety shield or guard is removed for any reason, it must be replaced before the machine is again operated.
4. When the use of hand tools is required to perform any part of assembly, installation, adjustment, maintaining, repairing, removal, or moving, be sure the tools used are designed and recommended by the tool manufacturer for that specific task.
5. Personal protection equipment including hard hat, safety glasses, safety shoes, and gloves are recommended during assembly, installation, operation, adjustment, maintaining, repairing, removal, or moving. Do not allow long hair, loose fitting clothing, or jewelry to be around moving parts.
6. Always use two people to handle heavy, unwieldy components during assembly, installation, removal or moving.
7. Never place any part of your body where it would be in danger if movement should occur during assembly, installation, operation, maintaining, repairing, removal or moving.
8. Never place yourself between the tractor and machine while implement is in operation.
9. Do not walk or work under a raised machine or attachment unless it is securely blocked or held in position. Do not depend on the tractor hydraulic system to hold the machine or attachment in place.
10. A heavy load can cause instability of the tractor. Use extreme care during travel. Slow down on turns and watch out for bumps. The tractor may need front counterweights to counterbalance the weight of the machine.
11. Never use alcoholic beverages or drugs which can hinder alertness or coordination while operating this equipment. Consult your doctor about operating this machine while taking prescription medications.
12. Do not allow riders on the machine or tractor at any time. There is no safe place for any riders.
13. Before you operate the machine, check over all pins, bolts, and connections to be sure all are securely in place. Replace any damaged or worn parts immediately.
14. Do not allow anyone who is not familiar with the safety rules and operation instructions to use this machine.
15. Never allow children to operate or be around this machine.
16. Use stabilizer bars, adjustable sway chains, or sway blocks on the tractor lift arms to keep the machine from swinging side to side. Adjust as tightly as practical for best performance.
17. Clear the work area of objects which might be picked up and snagged or entangled in the machine.
18. Keep hands, feet, hair, jewelry, and clothing away from all moving and/or rotating parts.

2.7 TRANSPORT SAFETY

1. Comply with state and local laws governing highway safety and movement of farm machinery on public roads.
2. The use of flashing amber lights is acceptable in most localities. However, some localities prohibit their use. Local laws should be checked for all highway lighting and marking requirements.
3. At all times, when driving the tractor and equipment on the road or highway under 20 mph (32 kph) use flashing amber warning lights and a slow moving vehicle (SMV) identification emblem. Do not exceed 20 mph (32 kph). Reduce speed on rough roads and surfaces.
4. Plan your route to avoid heavy traffic.
5. Always install transport locks, pins or brackets before transporting.
6. Do not drink and drive.
7. Be a safe and courteous driver. Always yield to oncoming traffic in all situations, including narrow bridges, intersections, etc. Watch for traffic when operating near or crossing roadways.
8. Turn into curves or go up or down hills only at a low speed and at a gradual steering angle. Make certain that at least 20% of the tractor's weight is on the front wheels to maintain safe steering. Slow down on rough or uneven surfaces.
9. Never allow riders on either tractor or machine.

2.8 STORAGE SAFETY

1. Store the unit in an area away from human activity.
2. Do not permit children to play on or around the stored machine.
3. Store the unit in a dry, level area. Support the frame with planks if required.

2.9 MAINTENANCE SAFETY

1. Good maintenance is your responsibility. Poor maintenance is an invitation to trouble.
2. Follow good shop practices.

- Keep service area clean and dry.
- Be sure electrical outlets and tools are properly grounded.
- Use adequate light for the job at hand.



3. Make sure there is plenty of ventilation. Never operate the engine of the towing vehicle in a closed building. The exhaust fumes may cause asphyxiation.
4. Before working on this machine, shut off the engine, set the brakes, and remove the ignition keys.
6. Never work under equipment unless it is blocked securely.
7. Use personal protection devices such as eye, hand and hearing protectors, when performing any service or maintenance work.
8. Where replacement parts are necessary for periodic maintenance and servicing, genuine factory replacement parts must be used to restore your equipment to original specifications. The manufacturer will not be responsible for injuries or damages caused by use of unapproved parts and/or accessories.
9. A fire extinguisher and first aid kit should be kept readily accessible while performing maintenance on this equipment.



10. Periodically tighten all bolts, nuts and screws and check that all cotter pins are properly installed to ensure unit is in a safe condition.
11. When completing a maintenance or service function, make sure all safety shields and devices are installed before placing unit in service.

3 SAFETY SIGN LOCATIONS

Good safety requires that you familiarize yourself with the various safety signs, the type of warning and the area, or particular function related to that area, that requires your SAFETY AWARENESS.

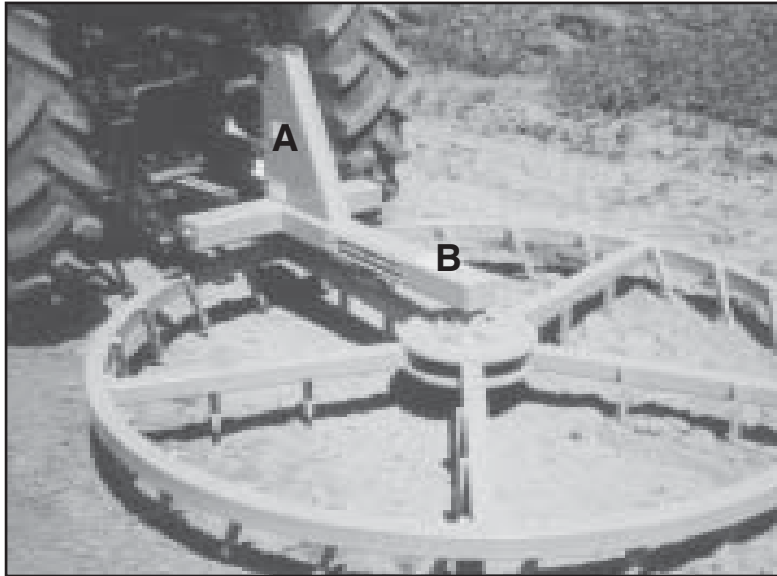

A

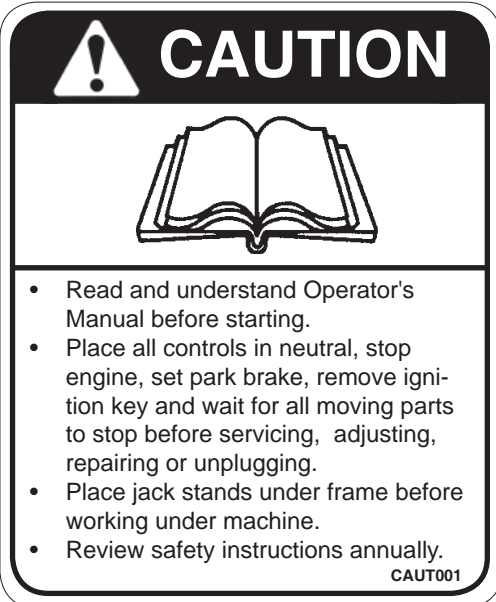

CAUTION



- Read and understand Operator's Manual before starting.
- Place all controls in neutral, stop engine, set park brake, remove ignition key and wait for all moving parts to stop before servicing, adjusting, repairing or unplugging.
- Place jack stands under frame before working under machine.
- Review safety instructions annually.

CAUT001

B



WARNING



**PINCH POINT HAZARD
KEEP AWAY**

To prevent serious injury or death from pinch point hazard:

- Place all controls in neutral, stop engine, set park brake, remove ignition key and wait for all moving parts to stop before servicing, adjusting, repairing or unplugging.
- Keep hands, feet, hair and clothing away from moving parts.
- Keep others away.

WARN001

REMEMBER - If safety signs have been damaged, removed, become illegible or parts replaced without signs, new signs must be applied. New signs are available from your authorized dealer.

4 OPERATION



OPERATING SAFETY

1. Read and understand the Operator's Manual and all safety signs before operating, servicing, adjusting, repairing or unplugging.
2. Do not allow riders.
3. Install and secure all guards and shields before starting or operating.
4. Keep hands, feet, hair and clothing away from moving parts.
5. Place all controls in neutral, stop tractor engine, set park brake, remove ignition key and wait for all moving parts to stop before servicing, adjusting, repairing or unplugging.
6. Place all tractor and machine controls in neutral before starting.
7. Never start or operate machine unless sitting on tractor seat.
8. Clear the area of bystanders, especially small children, before starting.
9. Clean reflectors, SMV and lights before transporting.
10. Use hazard flashers on tractor when transporting.
11. Do not put hands or feet under machine while tractor engine is running.
12. Review safety instructions with all operators annually.

4.1 TO THE NEW OPERATOR OR OWNER

Arena-Harrows are designed as a light duty rotating harrow for leveling and smoothing the surface in horse arenas and racetracks. Be familiar with the machine before starting.

It is the responsibility of the owner or operator to read this manual and to train all other operators before they start working with the machine. Follow all safety instructions exactly. Safety is everyone's business. By following recommended procedures, a safe working environment is provided for the operator, bystanders and the area around the worksite. Untrained operators are not qualified to operate the machine.

Many features incorporated into this machine are the result of suggestions made by customers like you. Read this manual carefully to learn how to operate the machine safely and how to set it to provide maximum field efficiency. By following the operating instructions in conjunction with a good maintenance program, your Arena-Harrows will provide many years of trouble-free service.

4.2 FIELD OPERATION



OPERATING SAFETY

1. Read and understand the Operator's Manual and all safety signs before operating, servicing, adjusting, repairing or unplugging.
2. Do not allow riders.
3. Install and secure all guards and shields before starting or operating.
4. Keep hands, feet, hair and clothing away from moving parts.
5. Place all controls in neutral, stop tractor engine, set park brake, remove ignition key and wait for all moving parts to stop before servicing, adjusting, repairing or unplugging.
6. Place all tractor and machine controls in neutral before starting.
7. Never start or operate machine unless sitting on tractor seat.
8. Clear the area of bystanders, especially small children, before starting.
9. Clean reflectors, SMV and lights before transporting.
10. Use hazard flashers on tractor when transporting.
11. Do not put hands or feet under machine while tractor engine is running.
12. Review safety instructions with all operators annually.

Arena-Harrows are designed as light to moderate duty harrows that rotate while moving forward to level and smooth the surface in horse arenas and race tracks. However the operator has the responsibility of being familiar with all operating and safety procedures and following them.

Each operator should review this section of the manual at the start of the season and as often as required to be familiar with the machine. When using, follow this procedure:

1. Review and follow the Pre-Operation Checklist.
2. Attach the tractor to the machine.
 - a. Lift the machine and slide the balls over the mounting pins. Install the retainers.
 - b. Attach the top link to the mast. Install the retainer.

IMPORTANT

Do not use on a tractor of more than 60 horsepower. Larger tractors can overload and bend the frame or teeth.

- c. Always engage the anti-sway components on each lift arm to keep the unit from moving from side-to-side during operation.

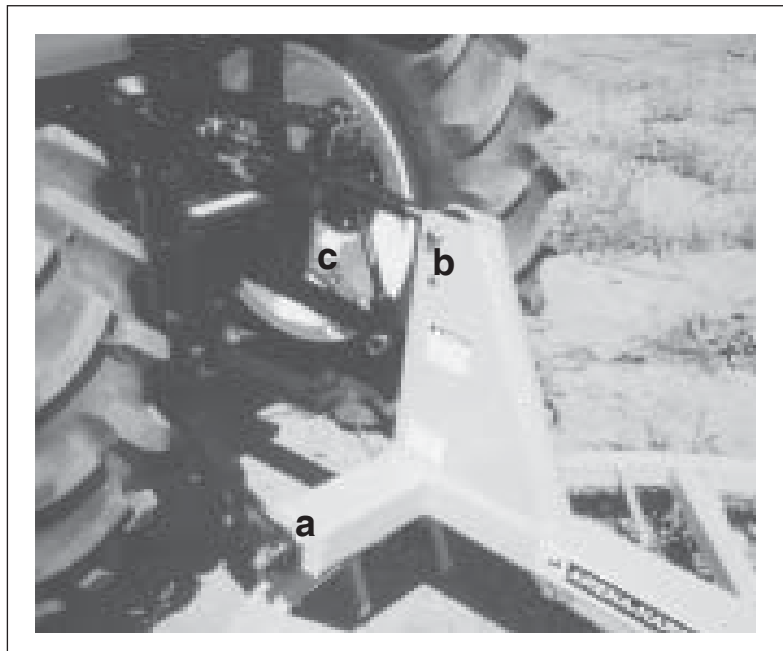

Fig. 2 ATTACHED

3. Before going to the working area review Section 4.3 Transporting.
4. Drive to the working area and stop in a level area.
5. Lower into working position.
6. **Set the Machine:**

- a. **Angle the Frame:**
Use the screw jack on the right lift arm to angle the frame from side-to-side. Set so the right side of the circular frame is 5 to 10 inches lower than the left.

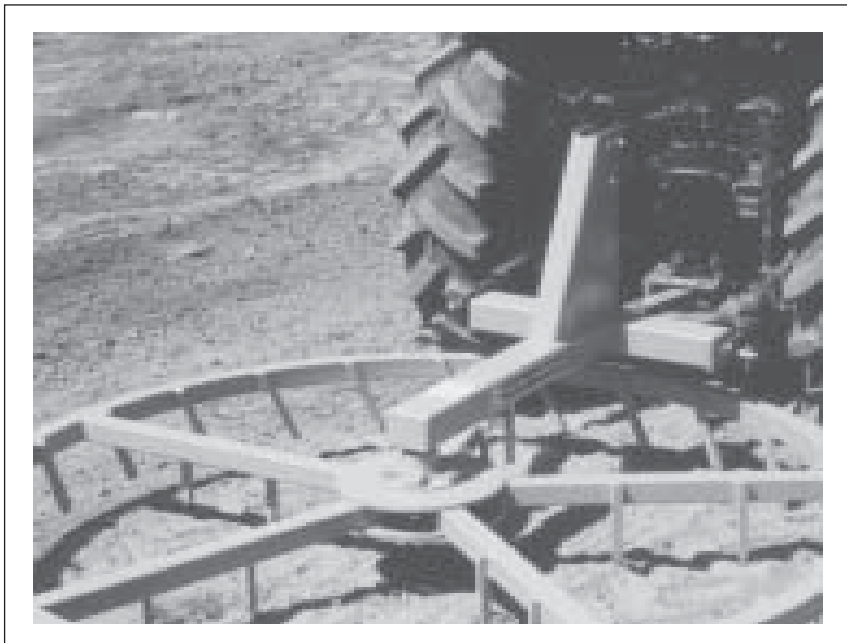

Fig. 3 FRAME ANGLE

- b. **Frame Angle:**
Use the turnbuckle on the top link to set the frame angle. Normally the frame should be set so the front and right side of the circular frame is 3 to 6 inches lower than its opposite side.

- c. **3 Point Hitch:**
Set the 3 point hitch on the tractor into the "float" mode to allow the teeth to follow the contour of the ground. This will maintain constant teeth pressure at all times.

- d. **Category:**
The Harrow is designed with a Category I, 3 point hitch. Always use the appropriate pins and retainers when hooking to the tractor.

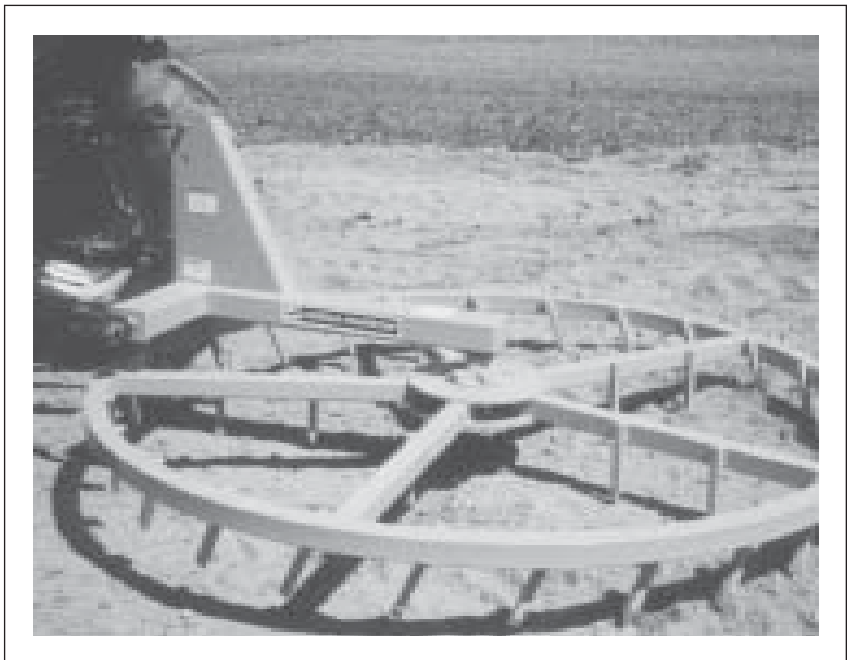

Fig. 4 HARROWING

7. Drive over the area to be harrowed.

8. **Ground Speed:**

Although the Arena-Harrow can be operated at any speed, it is recommended that slow speeds be used. High speeds can lead to skipping by the harrow teeth and doing an uneven job. Two to four mph will give the best results. The operator will have to experiment a little to determine the best speed. Use the type of job being done as a guide.

9. **Operating Hints:**

a. The Arena-Harrow works well to spread and level material over a surface. Make several passes to spread and level the surface evenly.

b. When working in an area with vegetation or weeds, raise the Arena-Harrow to allow any material to drop off the teeth. Do not let material accumulate on the teeth. It can affect the leveling action by the teeth.

c. Make several passes to distribute material into ruts or low spots. Approach the rut from more than one angle to obtain the best distribution.

d. Always set the circular frame 3 to 6 inches off from level in both side-to-side and for-aft to get the best harrowing action.



Fig. 5 WORKING

4.3 TRANSPORTING



TRANSPORT SAFETY

1. **Make sure you are in compliance with all local regulations regarding transporting equipment on public roads and highways.**
2. **Make sure the SMV (Slow Moving Vehicle) emblem and all the lights and reflectors that are required by the local highway and transport authorities are in place, are clean and can be seen clearly by all overtaking and oncoming traffic.**
3. **Do not allow anyone to ride on the Rotary Harrow or tractor during transport.**
4. **Do not exceed 20 mph (32 kph). Reduce speed on rough roads and surfaces.**
5. **Use retainers on the mounting pins when attaching.**
6. **Always use hazard flashers on the tractor when transporting unless prohibited by law.**

When transporting the machine, review and follow these instructions:

1. Be sure all bystanders are clear of the machine.
2. Be sure that the machine is securely attached to the tractor and all retainer pins are installed.
3. Be sure you have installed extra weights on the front of the tractor if required.
4. Clean the SMV emblem, lights and reflectors and be sure they are working.
5. Be sure you are in compliance with all applicable lighting and marking regulations when transporting. Check with your local authorities.
6. Be sure your machine can clearly be seen by overtaking and oncoming traffic.
7. Keep to the right and yield the right-of-way to allow faster traffic to pass. Drive on the road shoulder if permitted by law.
8. Do not allow riders.
9. Always use hazard flashers on the tractor when transporting unless prohibited by law.

4.4 STORAGE



STORAGE SAFETY

1. **Store the unit in an area away from human activity.**
2. **Do not permit children to play on or around the stored machine.**
3. **Store the unit in a dry, level area. Support the frame with planks if required.**

After the season's use, the machine should be thoroughly inspected and prepared for storage. Repair or replace any worn or damaged components to prevent any unnecessary down time at the start of next season. To insure a long, trouble free life, this procedure should be followed when preparing the unit for storage:

1. Clear the area of bystanders, especially small children.
2. Thoroughly wash the machine using a pressure washer to remove all dirt, mud, debris and residue.
3. Inspect the teeth and pivot for damage or entangled material. Repair or replace damaged parts. Remove all entangled material.
4. Touch up all paint nicks and scratches to prevent rusting.
5. Move to storage area.
6. Select an area that is dry, level and free of debris.
7. Unhook from tractor.
8. If the machine cannot be placed inside, cover with a waterproof tarpaulin and tie securely in place.
9. Store the machine in an area away from human activity.
10. Do not allow children to play on or around the stored machine.

5 ASSEMBLY

The machine is shipped from the factory in a partially disassembled form that allows for easy and convenient shipping.

When preparing for the customer, follow this procedure:

1. Clear the area of bystanders, especially small children.
2. Use 2 men to guide or direct and handle the heavy and bulky components.
3. Use a crane, hoist or forklift of sufficient capacity and stability to handle the components.
4. Attach to the lifting device, remove tie-downs, lift from the truck and move to the assembly area. Drive slow and keep the machine close to the ground.
5. Remove the pallet tie downs.
6. Place the circular frame on blocks that are high enough to provide access to the hub bolts.
7. Mount the hub to the center frame.
8. Tighten fasteners to their specified torque.
9. Install tines onto circular frame.
10. Check tightness of all bolts and nuts.



Fig. 6 SHIPPING CONFIGURATION



Fig. 7 HUB BOLTS

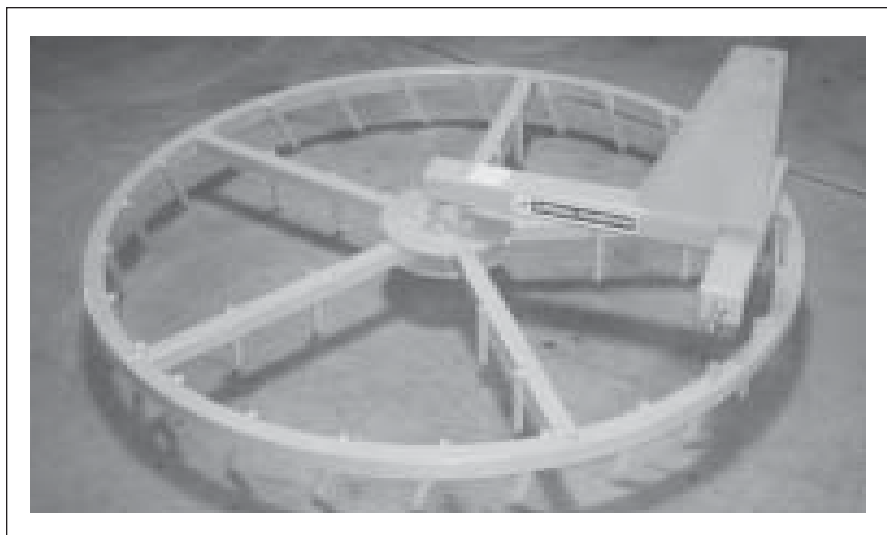
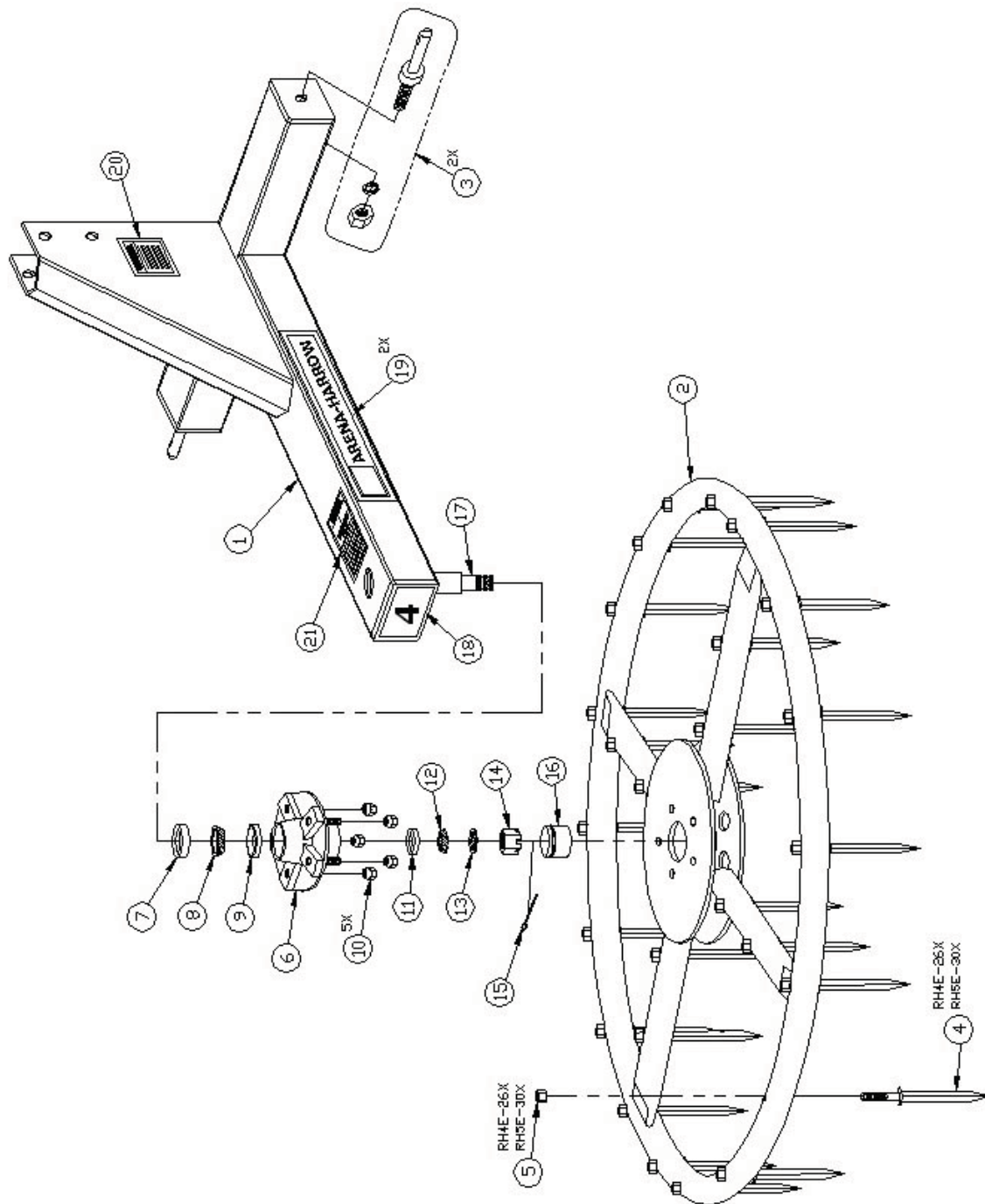

Fig. 8 ASSEMBLED

6 REPLACEMENT PARTS

6.1 PARTS DIAGRAM



6.2 PARTS LIST

<u>REF.</u>	<u>QTY.</u>	<u>PART NO.</u>	<u>DESCRIPTION</u>
1	1	RHE-2400	A-frame Assembly
2	1	RHE-2200	4' Ring Assembly
2	1	RHE-2300	5' Ring Assembly (Not Shown)
3	2	RHE-0406	P-728 Hitch Pin
4	26-30	FD8525D	7/16" Spike
5	26-30	RHE-0205	7/16" NC Rev. Lock Nut
6	1	RHE-0408	CH-0011 5 Bolt Ag. Hub, Complete
7	1	RHE-0409	CH-0041 2 9/16" O.D. SL173 Seal
8	1	RHE-0410	L68149 Inner Bearing
9	1	RHE-0411	L68111 Inner Race
10	5	RHE-0412	CH-0042 9/16" NF Lug Nut
11	1	RHE-0413	L44610 Outer Race
12	1	RHE-0414	L44649 Outer Bearing
13	1	RHE-0415	CH-0031 Washer
14	1	RHE-0416	CH-0032 Slotted Nut
15	1	RHE-0417	CH-0033 Cotter Pin
16	1	RHE-0418	CH-0034 Grease Cap
17	1	RHE-0419	CH-0014 Ag Spindle
18	1	RHE-0420	GRHE4 Decal
18	1	RHE-0421	GRHE5 Decal (Not Shown)
19	2	RHE-0422	Arena-Harrow Decal
20	1	CAUT-001	Caution Decal
21	1	WARN-001	Warning Decal

7 SPECIFICATIONS

7.1 MECHANICAL

MODELS	RRH5	RRH6	RRH7	RRH8
RING DIAMETER	5'	6'	7'	8'
HITCH CATEGROY	CAT. 1	CAT. 1	CAT. 1	CAT. 1
TOOTH SIZE	3/4" X 8"	3/4" X 8"	3/4" X 8"	3/4" X 8"
RING SIZE	2" X 2"	2" X 2"	2" X 2"	2" X 2"
WEIGHT	210	250	295	335

SPECIFICATIONS ARE SUBJECT TO CHANGE WITHOUT NOTICE

7.2 BOLT TORQUE

CHECKING BOLT TORQUE

The tables shown below give correct torque values for various bolts and capscrews. Tighten all bolts to the torques specified in chart unless otherwise noted. Check tightness of bolts periodically, using bolt torque chart as a guide. Replace hardware with the same strength bolt.

ENGLISH TORQUE SPECIFICATIONS

Bolt Diameter "A"	Bolt Torque *					
	SAE 2		SAE 5		SAE 8	
	N.m	(lb-ft)	N.m	(lb-ft)	N.m	(lb-ft)
1/4"	8	(6)	12	(9)	17	(12)
5/16"	13	(10)	25	(19)	36	(27)
3/8"	27	(20)	45	(33)	63	(45)
7/16"	41	(30)	72	(53)	100	(75)
1/2"	61	(45)	110	(80)	155	(115)
9/16"	95	(70)	155	(115)	220	(165)
5/8"	128	(95)	215	(160)	305	(220)
3/4"	225	(165)	390	(290)	540	(400)
7/8"	230	(170)	570	(420)	880	(650)
1"	345	(225)	850	(630)	1320	(970)

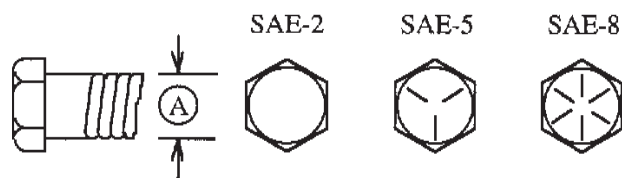

Torque figures indicated above are valid for non-greased or non-oiled threads and heads unless otherwise specified. Therefore, do not grease or oil bolts or capscrews unless otherwise specified in this manual. When using locking elements, increase torque values by 5%.

* Torque value for bolts and capscrews are identified by their head markings.

8 TROUBLE SHOOTING

Arena-Harrows are a large circular, rotating frame equipped with teeth for leveling soil. It is a simple and reliable system that requires minimal maintenance.

In the following section, we have listed many of the problems, causes and solutions to the problems that you may encounter.

If you encounter a problem that is difficult to solve, even after having read through this trouble shooting section, please call your local dealer, distributor or the factory. Before you call, please have this Operator's Manual and the serial number from your Arena-Harrow ready.

PROBLEM:	CAUSE:	SOLUTION:
Soil does not move ahead of teeth	Teeth skip over ground	Driving too fast, slow down
		Set hitch in "float" mode
	Wrong frame angle	Increase frame angle to give a more aggressive turning action

9 LIMITED WARRANTY



GEARMORE, INC., warrants each new Gearmore product to be free from defects in material and workmanship for a period of twelve (12) months from date of purchase to the original purchaser. This warranty shall not apply to implements or parts that have been subject to misuse, negligence, accident, or that have been altered in any way.

Our obligation shall be limited to repairing or replacement of any part, provided that such part is returned within thirty (30) days from date of failure to Gearmore through the dealer from whom the purchase was made, transportation charges prepaid.

This warranty shall not be interpreted to render us liable for injury or damages of any kind or nature, direct, consequential or contingent, to person or property. This warranty does not extend to loss of crops, loss because of delay in harvesting or any other expenses, for any other reasons.

Gearmore in no way warrants engines, tires, or other trade accessories, since these items are warranted separately by these respective manufacturers.

Gearmore reserves the right to make improvements in design or changes in specification at any time, without incurring any obligations to owners or units previously sold.

GEARMORE, INC.
13477 Benson Ave.
Chino, CA 91710

Always refer to and heed machine operating warning decals on machine.

The serial number of this product is stored in our computer database, thus submitting a warranty registration card is not required.