



FLAIL MOWER SHREDDER

**Operation, Service,
& Parts Manual
For Models:
GML41, 49, 61,
69, & 79**

February 2006

TABLE OF CONTENTS

Installation	1
Lubrication	2
Pre-Operation Check	3
Roller Height Control	4
Drive Belt Tension Adjustment	5
Troubleshooting	6
Safety Precautions	6
Deck Assembly	7 - 8
A-Frame Assembly	9
Parking Stand	10
Rotor Shaft Assembly	11 - 12
Quantity Matching Chart	13
Roller Assembly	14
Drive Assembly	15 - 16
Gearbox Assembly	17 - 18
Driveline Assembly	19
PTO Shaft	20 - 21
Limited Warranty	22

Date of Purchase:_____

Model Number:_____

Serial Number:_____

INSTALLATION

BEFORE ATTACHING THE MOWER TO THE TRACTOR

1. Make sure that the mower is suitable for your tractor's horsepower.

<u>MODELS</u>	<u>YOUR TRACTOR'S MAX. H.P.</u>
All GML Models	50



CAUTION: Please note that if these limits are exceeded, it will invalidate your warranty.

2. Make sure the lower links and top link on the 3-point hitch arms of your tractor are the correct size (Cat. I), so that they correspond to the size of the hitch on the mower you have purchased.

3. ***P.T.O. Installation:***

First, connect the P.T.O. shaft to the tractor. With the shaft in its shortest position, there should be about a 2" clearance between the end of the gearbox shaft and the end of the P.T.O. shaft. Should it be necessary to shorten the P.T.O. shaft, shorten both male and female shafts equally, keeping the protective tube covers 1" shorter than the steel tubes.

Particular attention should be given to carefully removing all burrs and to clean and lubricate the steel tubes and protective covers. There must be sufficient telescopic movement so that the two tubes do not touch the end of the P.T.O. shaft.

It is most important to carefully raise and lower the mower with the tractor hydraulic system, making sure that the P.T.O. shaft does not bottom or disengage the telescopic shaft tubes, otherwise damage may occur.

LUBRICATION



Grease all fittings according to the following schedule:

1. **CUTTING SHAFT (Ref. 1):** Grease at both ends lightly *after 8 hours* of operation. **DO NOT** overgrease. Left hand grease zerk is located on backside of belt housing.
2. **EXTENSION SHAFT (Ref. 2):** Grease extension shaft bearing *every 40 hours*.
3. **P.T.O. SHAFT:** The universal joints and overrunning clutch (option) need to be greased *every 8 hours*. The telescopic tubes should be greased *every 16 hours* and the shield retaining bearing should be greased *every 40 hours*.

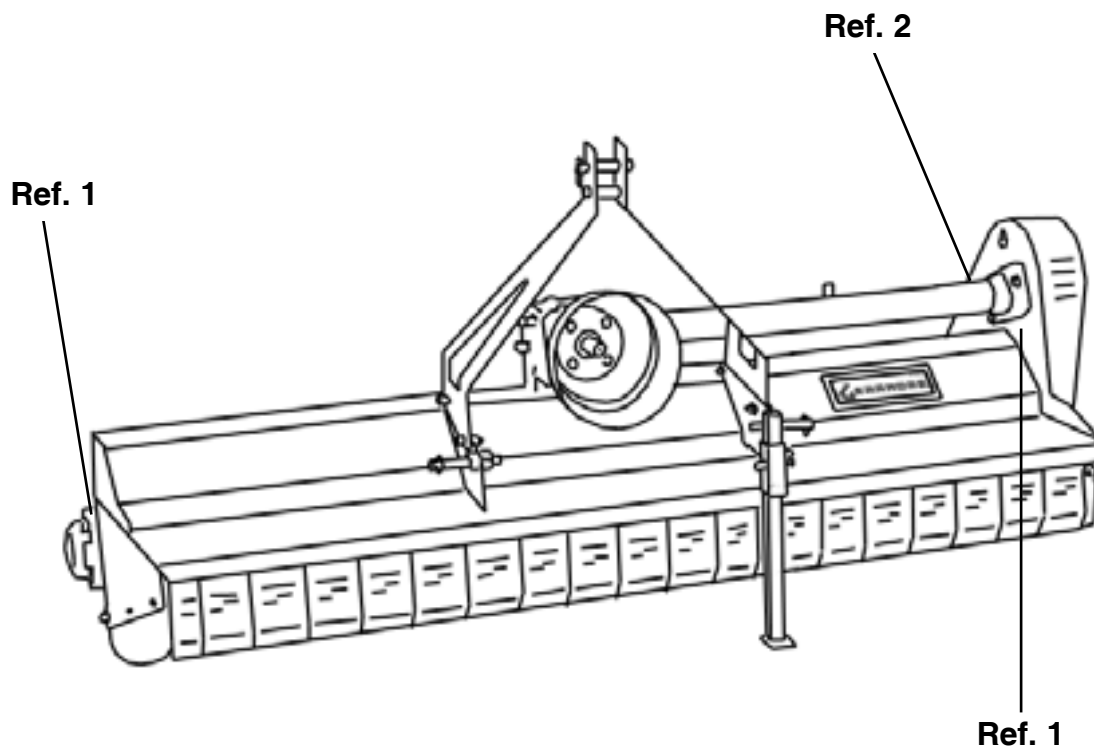

PRE-OPERATION CHECK

- ✓ Check tightness of all bolts and nuts.
- ✓ Check gearbox oil level (Grade SAE80W-90 gear oil).
- ✓ Grease all points, on all GML mowers.
- ✓ P.T.O. (power take-off) speed should not exceed 540 RPM (revolutions per minute).
- ✓ Check correct length of P.T.O. shaft. When fitted, there should be 3 3/4" free travel on male and female tubing (check in fully raised and fully lowered positions).
- ✓ The recommended cutting height, with the hammer or blade in its lowest position, is between 2" and 4" (*Ref. 1*). Basically, the fine height adjustment is achieved with the top link of the 3-point hitch. For a greater height adjustment, it is necessary to raise or lower the roller (*Ref. 2*).
- ✓ Drive belt should flex 3/8" (1 cm.) when pushed firmly with the finger.
- ✓ Mower should be completely cleaned after use and before storage.

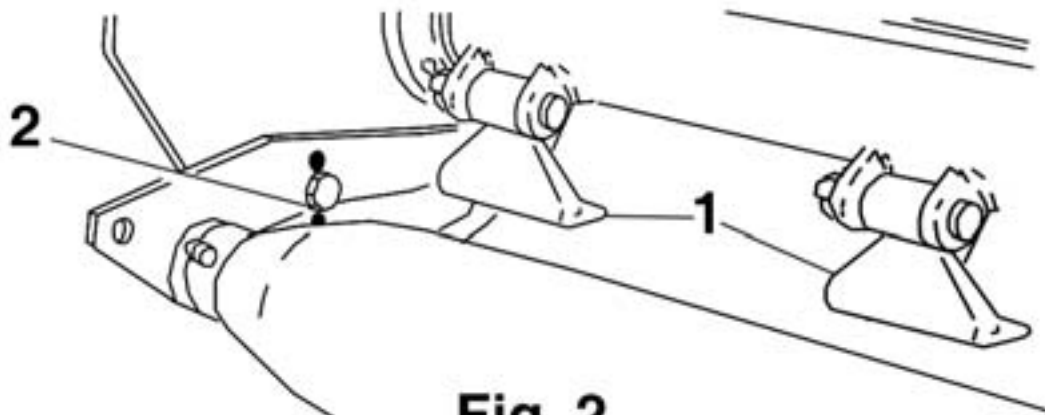

Fig. 2

ROLLER HEIGHT CONTROL

The roller can be adjusted for 2 or 3 cutting heights. By raising the roller, you get a shorter cut, by lowering it, a longer cut is achieved. You can also fine adjust the cutting height with the top link arm. By shortening the link arm, your cut is further from the ground.

A suggested cutting height is having the hammer tips about 2" from the ground.

You can control the power needed and the amount of wear on the hammers by this adjustment.

1. There is also an adjustment that can be made on the roller to control mulch size and power needed. By moving the roller toward the cutting shaft (*Fig. 7*), a finer mulch is produced, but requires more H.P.
2. By moving the roller away from the cutting shaft (*Fig. 7*), a coarser mulch is produced, requiring less H.P. In this case, we suggest closing the hatch to mulch prunings.
3. For more precise work and performance, we recommend spending 5 minutes adjusting your mower for the job, this can be done according to the previous recommendations.

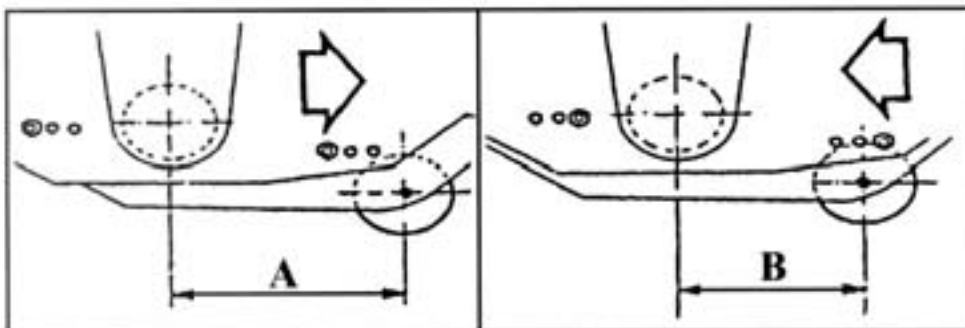

Fig. 7

DRIVE BELT TENSION ADJUSTMENT

1. Check belt tension before each use (*Fig. 8*). The tension is correct when you can depress one belt 1 cm ($3/8$ ") between the two pulleys. It is possible for you to insert a tool through the belt cover (*Fig. 9*), with mower stopped, to check the tension.
2. To adjust the belt tension, loosen bolts 1, 2, 3 & 4 and locknut 6 (*Fig. 9*). To adjust tension, move bolt 5. Do not forget to tighten all bolts after correct belt tension is achieved. If a belt requires replacement, replace all other belts as well.

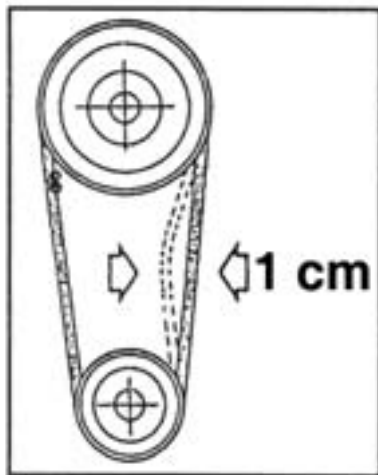

Fig. 8

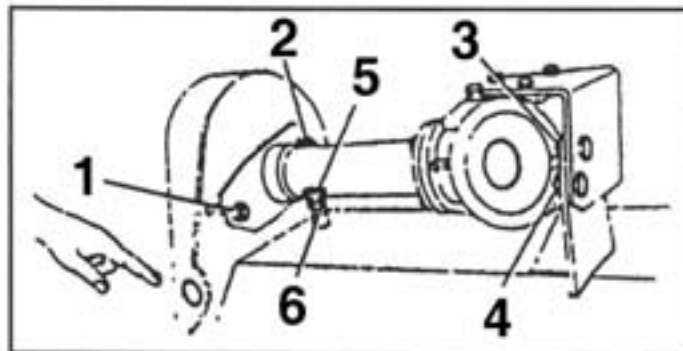

Fig. 9

TROUBLESHOOTING

1. Cutting shaft does not rotate properly:
 - a. Tighten drive belts to correct tension (*see page 5*).
 - b. Replace belts if they no longer can be adjusted properly.
2. Mower vibrates:
 - a. Check for loose or missing hammers or bolts.
 - b. Check for hammers that are unevenly worn. If one or more hammers is badly worn, replace all the hammers the first time. Keep the hammers that are in good shape for future replacement in worn series of hammers. For example: when replacing a worn hammer, replace it with a hammer of similar shape and weight. This will insure a balanced and vibration free cutting.
3. If the cutting shaft becomes jammed, reverse the rotation of the shaft to loosen and release the obstruction.
4. If the hammer mounting ears break off, they must be welded back in their exact position, otherwise the cutting shaft will be unbalanced.
5. If you have any questions or problems, it is always best to contact your dealer immediately.
6. When ordering spare parts, you must contact your authorized Gearmore dealer for original replacement parts. When doing so, please include the following information:
 - a. Model Number
 - b. Serial Number

SAFETY PRECAUTIONS

1. All adjustments, inspections and repairs must be made with tractor and mower completely stopped.
 - a. When the mower is in operation, make sure that there is no one near the flying debris from the mower, to prevent the possibility of serious injuries.
 - b. **ALWAYS** keep hands and feet away from a mower that is in operation.
 - c. Check that all guards and safety features are in place and in good operating condition.
2. While mowing, take the necessary precautions to insure operator's and others safety.
3. **DO NOT** make height adjustment using only the top link. This will cause flying debris to come out the front of the mower and toward the operator. Use the roller adjustment.

We thank you again for your choice of mowers and we remind you that the safety points outlined in this manual will help you do your work in a safe and efficient manner.

GML DECK ASSEMBLY

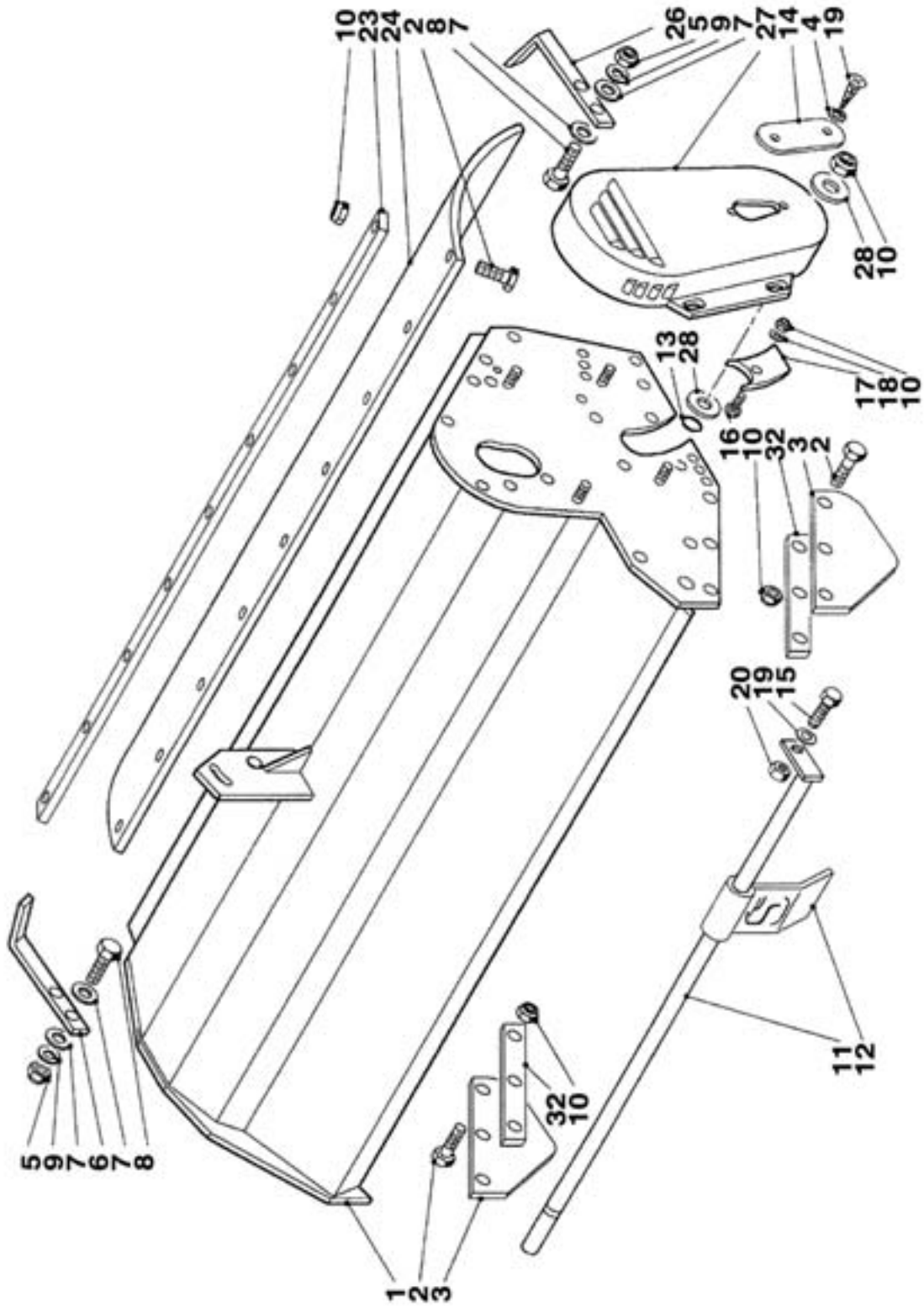

GML DECK ASSEMBLY

<u>REF#</u>	<u>QTY.</u>	<u>PART NO.</u>	<u>DESCRIPTION</u>
1	1	11301001	Deck Frame GML41
1	1	11301003	Deck Frame GML49
1	1	11301005	Deck Frame GML61
1	1	11301006	Deck Frame GML69
1	1	11301007	Deck Frame GML79
2	1	96605721	Bolt M8 x 30
3	1	13010033	Side Rubber Guard
4	1	97708871	Washer 5.3 x 10
5	1	97971821	Lock Nut M10
6	1	11310012	Support, Rubber Guard RH
7	1	97095111	Washer M10 Flat
8	1	96607721	Bolt M10 x 30
9	1	97494931	Washer M10 x 18
10	1	97971721	Lock Nut M8
11	1	15010005	Shaft, Stone Guard GML41
11	1	13010006	Shaft, Stone Guard GML49
11	1	15010008	Shaft, Stone Guard GML61
11	1	13010008	Shaft, Stone Guard GML69
11	1	13010009	Shaft, Stone Guard GML79
12	See Page 13	13010038	Stone Guard Standard
13	4	97277980	O-Ring 9.25 x 1.78
14	1	13010039	Cover
15	1	96612321	Bolt M14 x 35
16	1	96605721	Bolt M8 x 30
17	1	11301028	Plate
18	1	97494831	Washer M8
19	2	96964401	Sheet Metal Screw M4 x 9.5
20	1	97972321	Locknut M14
23	1	15008053	Clamp Strip GML41
23	1	14008021	Clamp Strip GML49
23	1	15008056	Clamp Strip GML61
23	1	14008023	Clamp Strip GML69
23	1	14008024	Clamp Strip GML79
24	1	11310020	Rubber Rear Guard GML41
24	1	11310021	Rubber Rear Guard GML49
24	1	11310022	Rubber Rear Guard GML61
24	1	11310023	Rubber Rear Guard GML69
24	1	11310024	Rubber Rear Guard GML79
26	1	11310011	Support, Rubber Guard LH
27	1	12010003	Belt Cover
28	1	97094921	Washer M8 x 24 x 2
32	2	13010034	Clamp Strip Front Rubber

GML A-FRAME ASSEMBLY

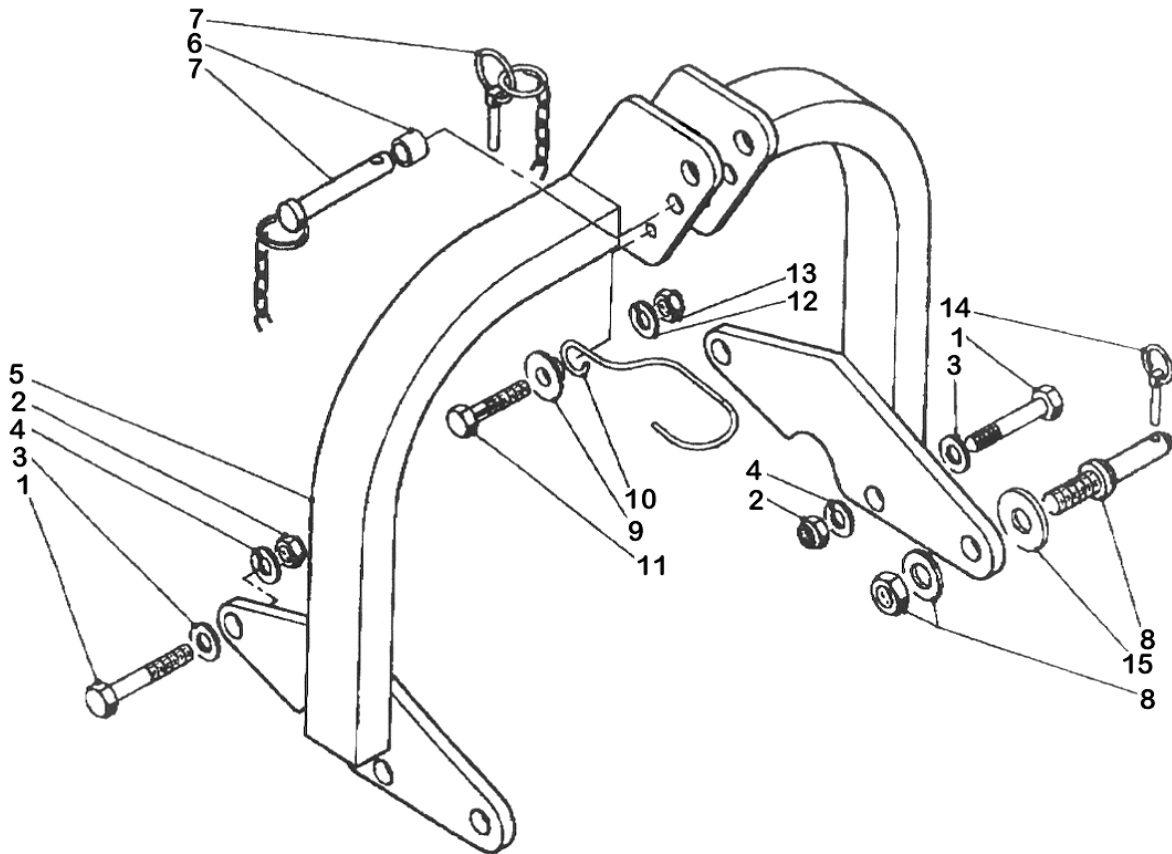

<u>REF#</u>	<u>QTY.</u>	<u>PART NO.</u>	<u>DESCRIPTION</u>
1	1	96612721	Bolt M14 x 55
2	1	97972321	Locknut M14
3	1	97095511	Washer M14
4	1	97495131	Spring Washer M14 x 24
5	1	11004095	3-Point Frame - Prior to 2008
5	1	11004149	3-Point Frame - After 2008
6	1	13004060	Spacer Cat. I to II
7	1	19704005	Top Link Pin c/w Lynch Pin
8	1	16004020	Bottom Link Pin c/w Nut & Washer
9	1	13004139	Spacer
10	1	14404021	PTO Shaft Rest
11	1	96609521	Bolt M12 x 50
12	1	97495031	Spring Washer M12
13	1	97972021	Nut M12
14	1	16004014	Lynch Pin
15	1	97096211	Washer M25 x 44 x 4

GML PARKING STAND

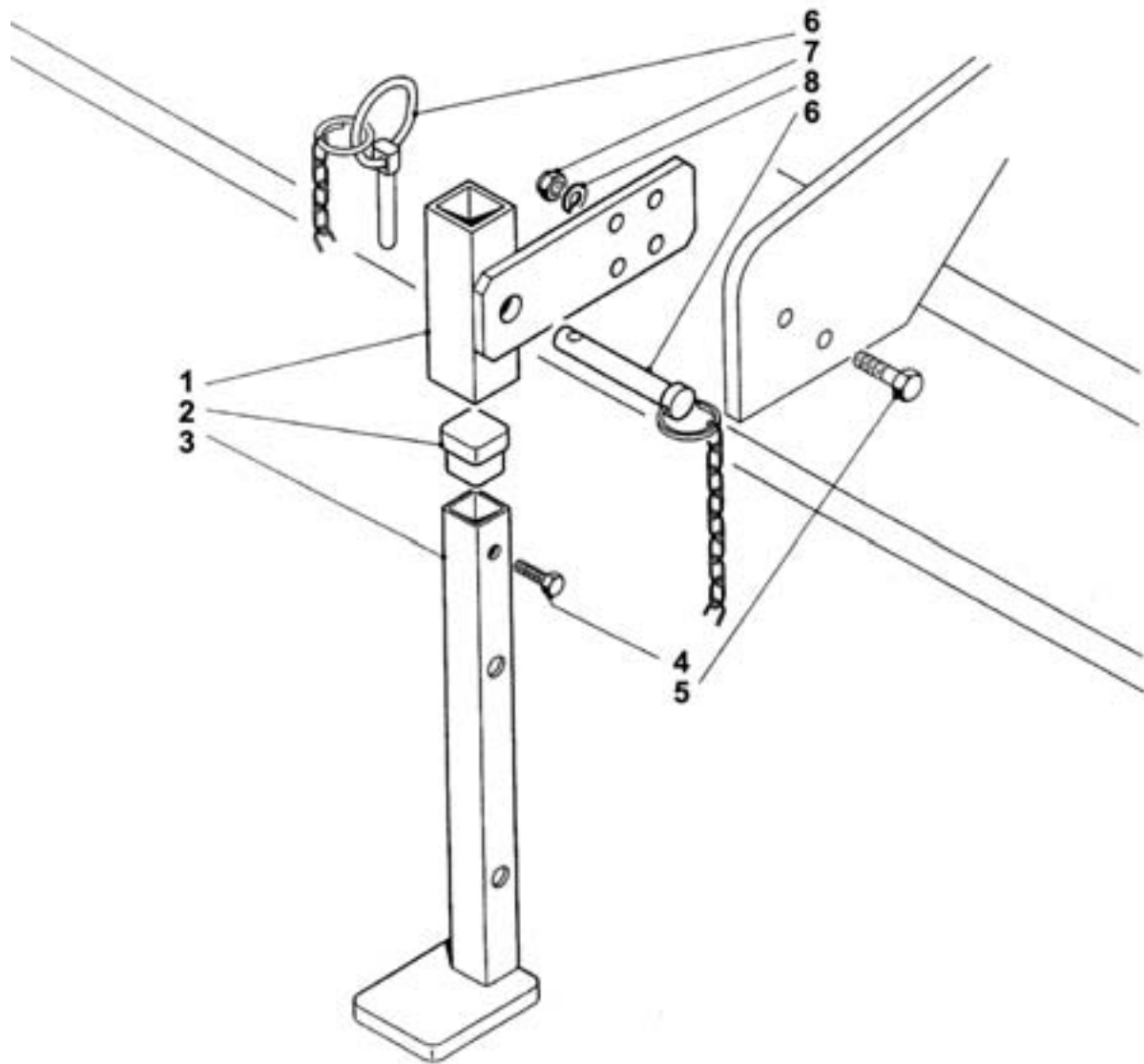

<u>REF#</u>	<u>QTY.</u>	<u>PART NO.</u>	<u>DESCRIPTION</u>
1	1	11011001	Leg Bracket
2	1	13011019	Rubber Cap
3	1	13011009	Leg
4	1	97486611	Bolt 6.3 x 19 Sheet Metal Screw
5	1	96610021	Bolt M12
6	1	14311010	Pin c/w Lynch Pin
7	1	97972031	Nut M12
8	1	97495031	Washer 12.2 x 21

GML ROTOR SHAFT ASSEMBLY

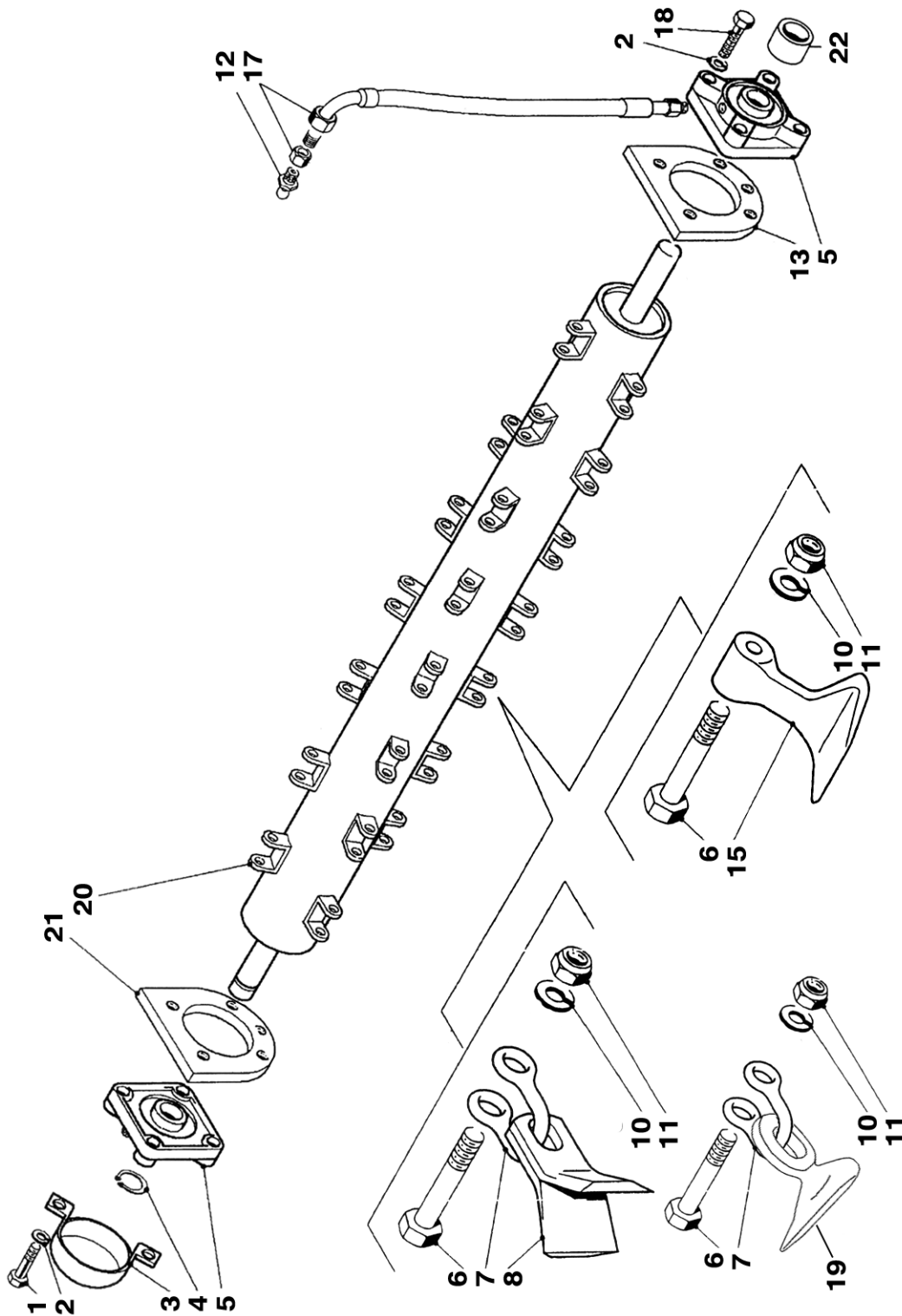

GML ROTOR SHAFT ASSEMBLY

<u>REF#</u>	<u>QTY.</u>	<u>PART NO.</u>	<u>DESCRIPTION</u>
1	8	97052121	Bolt M14 x 45
2	1	97495134	Washer M14 x 24
3	1	11310025	Rotor End Cover
4	1	47140	Circlip E40 x 1.75
5	2	UCF208	Bearing Assy - UCF208
6	See Page 13	11302004	Bolt M12 x 80
7	See Page 13	13002100	Shackle
8	See Page 13	15002049	Y Flail Blade
10	1	97495034	Spring Washer A13
11	See Page 13	97972021	Lock Nut M12
12	1	97036611	Grease Zerk M6
13	1	11302022	Clamp Plate L.H.
14	1	11302001	Rotor Assembly GML41 Fixed Hammer
14	1	11302003	Rotor Assembly GML49 Fixed Hammer
14	1	11302005	Rotor Assembly GML61 Fixed Hammer
14	1	11302006	Rotor Assembly GML69 Fixed Hammer
14	1	11302007	Rotor Assembly GML79 Fixed Hammer
14	1	11302052	Y Flail Rotor Assembly GML41
14	1	11302053	Y Flail Rotor Assembly GML49
14	1	11302054	Y Flail Rotor Assembly GML61
14	1	11302055	Y Flail Rotor Assembly GML69
14	1	11302056	Y Flail Rotor Assembly GML79
14	1	11302096	Rotor Assembly Swinging Hammer GML41
14	1	11302097	Rotor Assembly Swinging Hammer GML49
14	1	11302098	Rotor Assembly Swinging Hammer GML61
14	1	11302099	Rotor Assembly Swinging Hammer GML69
14	1	11302100	Rotor Assembly Swinging Hammer GML79
15	See Page 13	11302040	GML Hammer/Blade
17	1	21002020	External Greaser Assembly Kit
18	4	96612421	Bolt M14 x 40
19	See Page 13	11302002	Swinging Hammer
20	See Page 13	21002006	Rotor Lug
21	1	11302008	Clamp Plate R.H.
22	1	11302030	Spacer Bushing

QUANTITY MATCHING CHART

PART NO.	DESCRIPTION	MODELS				
		GML41	GML49	GML61	GML69	GML79
13010003	Deflector 4"	10	11	14	16	19
11302002	Swinging Hammer	18	24	27	33	39
11302040	Hammer Knife	18	24	27	33	39
99020001	Bolt, Knife M12 x , 8.8	18	24	27	33	39
97972021	Lock Nut, Knife M12	18	24	27	33	39
13002100	Shackle, Y Knife	18	24	27	33	39
15002049	Y Flail Only	36	48	54	66	78
21002006	Rotor Lug	18	24	27	33	39

GML ROLLER ASSEMBLY

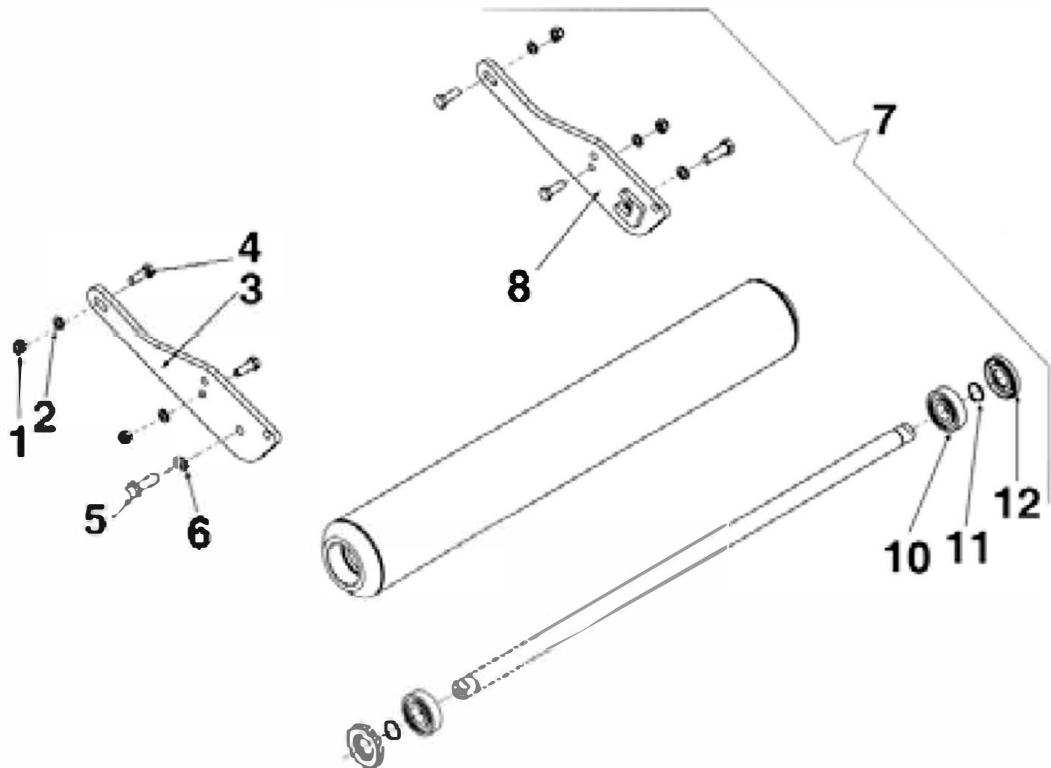

<u>REF#</u>	<u>QTY.</u>	<u>PART NO.</u>	<u>DESCRIPTION</u>
1	1	97972021	Lock Nut M12
2	1	97495034	Lock Washer D12
3	1	11305017	Roller Support L.H.
4	1	96610021	Bolt M12 x 35
5	1	96612221	Bolt M14 x 30
6	1	97495134	Washer D14
7	1	11305011	Roller GML41
7	1	11305012	Roller GML49
7	1	11305013	Roller GML61
7	1	11305014	Roller GML69
7	1	11305015	Roller GML79
8	1	11305016	Roller Support R.H.
9	1	11305024	Rod GML41
10	2	6306-2RS	Bearing 30 x 72 x 19
10	2	6206-2RS	Bearing 30 x 62 x 19 (Old Style - Before 2001)
11	2	47130	Circlip E30
12	2	30X72X10	Oil Seal
12	2	30X62X10	Oil Seal (Old Style - Before 2001)

GML DRIVE ASSEMBLY

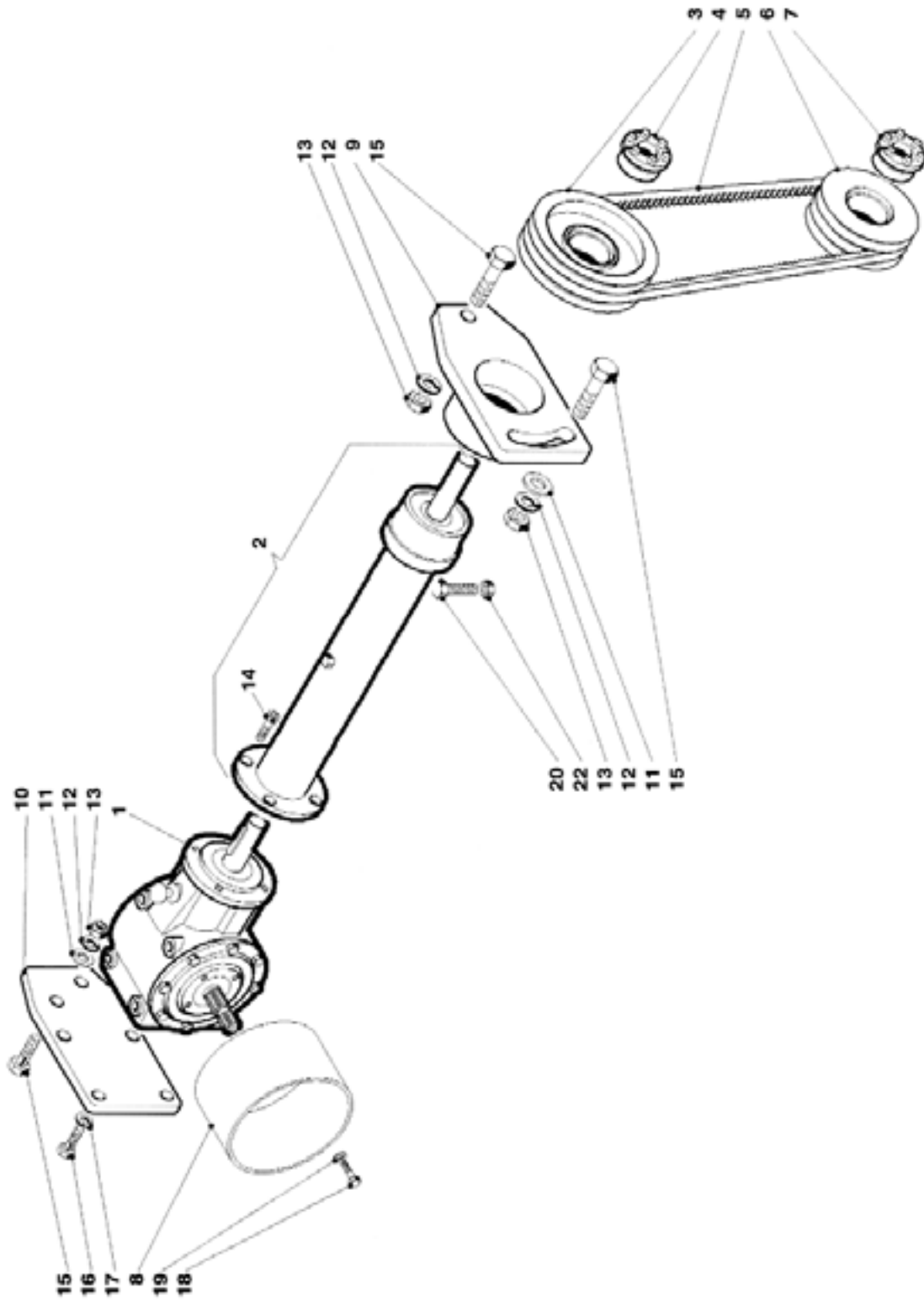

GML DRIVE ASSEMBLY

<u>REF#</u>	<u>QTY.</u>	<u>PART NO.</u>	<u>DESCRIPTION</u>
1	1	11303010	Gearbox
2	1	11303017	Extension Shaft GML41
2	1	11303018	Extension Shaft GML49
2	1	11303019	Extension Shaft GML61
2	1	11303016	Extension Shaft GML69
2	1	11303020	Extension Shaft GML79
3	1	11303034	Top Pulley 3SPB200
4	1	13003005	Taper Lock 35 x 80
5	3	15003060	Belts BX44
6	1	11303033	Bottom Pulley 3SPB140
7	1	15003054	Taper Lock 40 x 80
8	1	14310012	Circular Protection
9	1	11303032	Extension Shaft Adaptor
10	1	11003014	Plate F/Gearbox
11	1	97093311	Washer M14
12	1	97495134	Washer 14.2 x 24
13	1	97972321	Locknut M14-6S
14	1	96692223	Bolt M10 x 30 Allan
15	1	96612421	Bolt M14 x 40
16	1	96609827	Bolt M12 x 25
17	1	97495034	Washer 12.2 x 21
18	1	96605321	Bolt M8 x 12
19	1	97094921	Smooth Washer M8 9 x 24 x 2
20	1	96610121	Bolt M12 x 40
22	1	96979971	Nut M12

GML GEARBOX ASSEMBLY

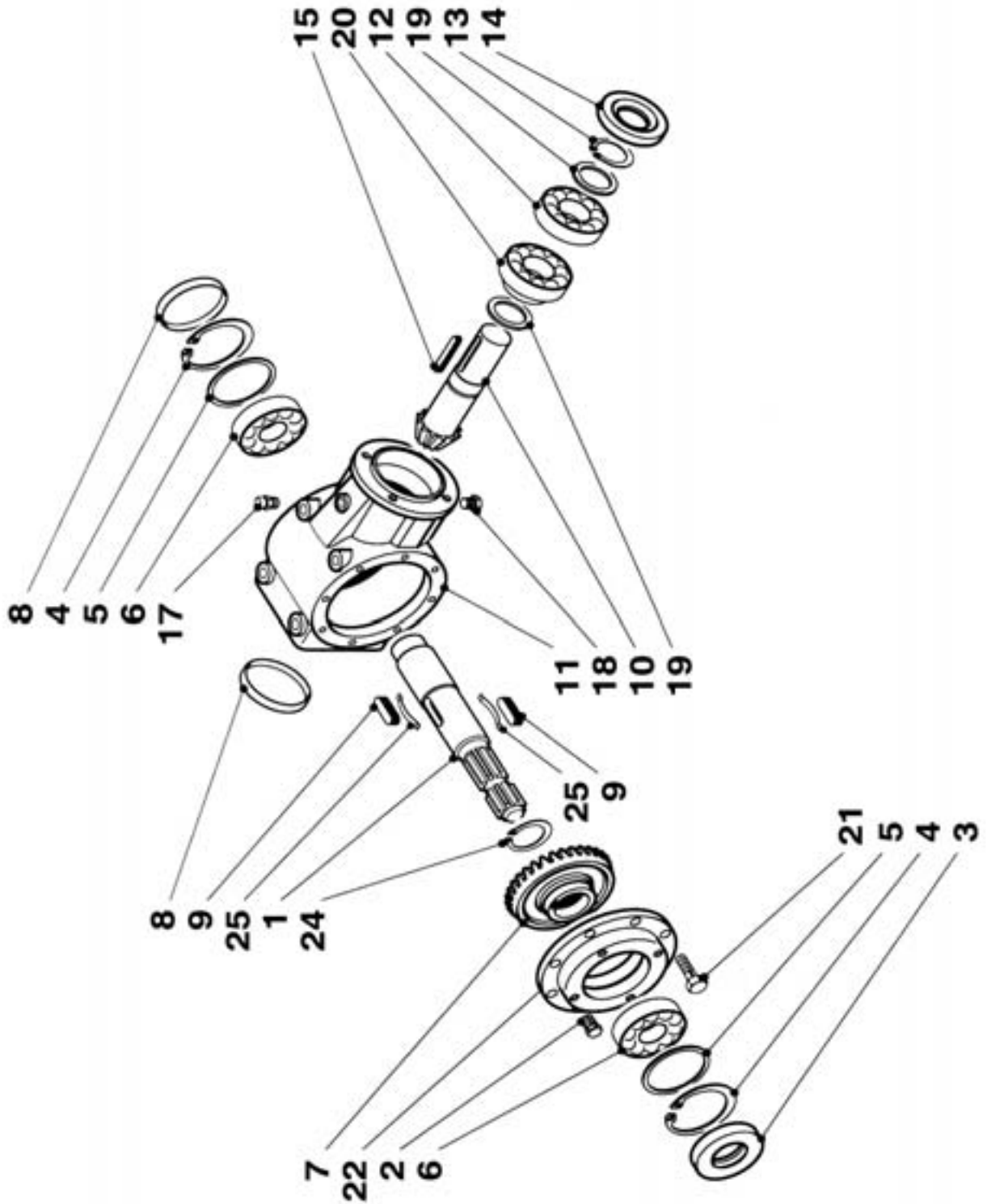

GML GEARBOX ASSEMBLY

<u>REF#</u>	<u>QTY.</u>	<u>PART NO.</u>	<u>DESCRIPTION</u>
1	1	48030615	Spl. Shaft F.W. 1" 3/8 Z6
1	1	48030993	Cros. Splin. Shaft F.W.
2	1	48403230	Plug 1/4 GAS
3	1	35X80X10	Oil Seal
4	1	47180	Circlip E80
5	1	48030884	Spacer 69 x 79.9
6	1	6307	Bearing 35 x 80 x 21
7	1	48030618	Taper Crown
8	1	48030267	Closing Cap 80 x 10
9	1	48030799	Key For Free Wheel
10	1	48030889	Pinion Shaft Z=12; M=3.45
11	1	48403046	Gearbox
12	1	6207	Bearing 35 x 72 x 17
13	1	47135	Circlip E35
14	1	35X72X10	Oil Seal
15	1	48030900	Key A10 x 8 x 45
16	1	96607627	Bolt M10 x 25
17	1	48030003	Breather Plug
18	1	48030246	Plut 3/8 NPT
19	1	48030281	Spacer 35.3 x 48
20	1	30207	Bearing
21	1	48030788	Bolt M10 x 22
22	1	48030887	Cover
24	1	47242	Circlip E42
25	1	48030983	Spring For Free Wheel

GML DRIVELINE ASSEMBLY

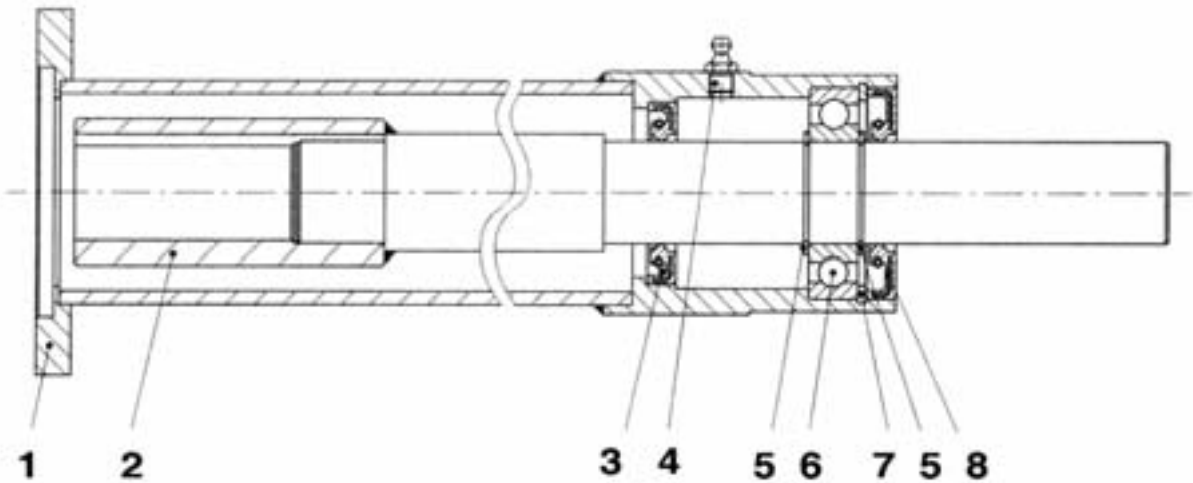

<u>REF#</u>	<u>QTY.</u>	<u>PART NO.</u>	<u>DESCRIPTION</u>
1	1	11303050	Ext. Sh. L=276
1	1	11303051	Ext. Sh. L=396 GML41
1	1	11303052	Ext. Sh. L=496 GML49
1	1	11303053	Ext. Sh. L=646 GML61
1	1	11303054	Ext. Sh. L=746 GML69
1	1	11303055	Ext. Sh. L=871 GML79
2	1	11303056	Cpl. Shaft Ext. L=276
2	1	11303057	Cpl. Shaft Ext. L=396 GML41
2	1	11303058	Cpl. Shaft Ext. L=496 GML49
2	1	11303059	Cpl. Shaft Ext. L=646 GML61
2	1	11303060	Cpl. Shaft Ext. L=746 GML69
2	1	11303061	Cpl. Shaft Ext. L=871 GML79
3	1	35X62X10	Oil Seal
4	1	97036711	Grease Nipple UNI 7663
5	1	47135	Circlip E35
6	1	6207	Bearing 35 x 72 x 17
7	1	47172	Circlip E72
8	1	35X72X10	Oil Seal

GML PTO SHAFT

Bondioli & Pavesi

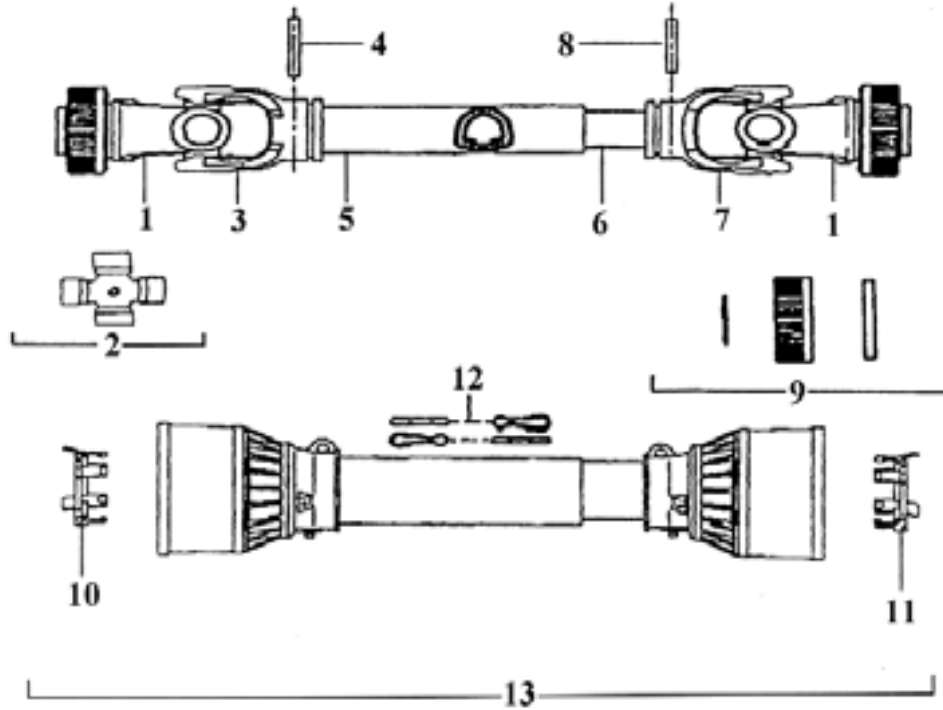

<u>REF#</u>	<u>QTY.</u>	<u>PART NO.</u>	<u>DESCRIPTION</u>
1	2	572040351	RS Yoke 1-3/8 6-Spline
2	2	41204	#4 Cross Kit
3	1	204046851	Outer Tube Yoke
4	1	341038000	Roll Pin O.T.
5	1	225120860	Outer Drive Tube 860mm
6	1	225100860	Inner Drive Tube 860mm
7	1	204046852	Inner Tube Yoke
8	1	341048000	Roll Pin I.T.
9	2	240002451	RS Collar Kit
10	1	255040005	Shield Bearing Outer
11	1	255040006	Shield Bearing Inner
12	2	252000001	Safety Chain
13	1	5F04086F6	Complete Shield w/Bearings
	1	7104071UCR07R07	Complete Driveline Assembly

Please specify driveline manufacturer when ordering parts.

GML PTO SHAFT

Weasler

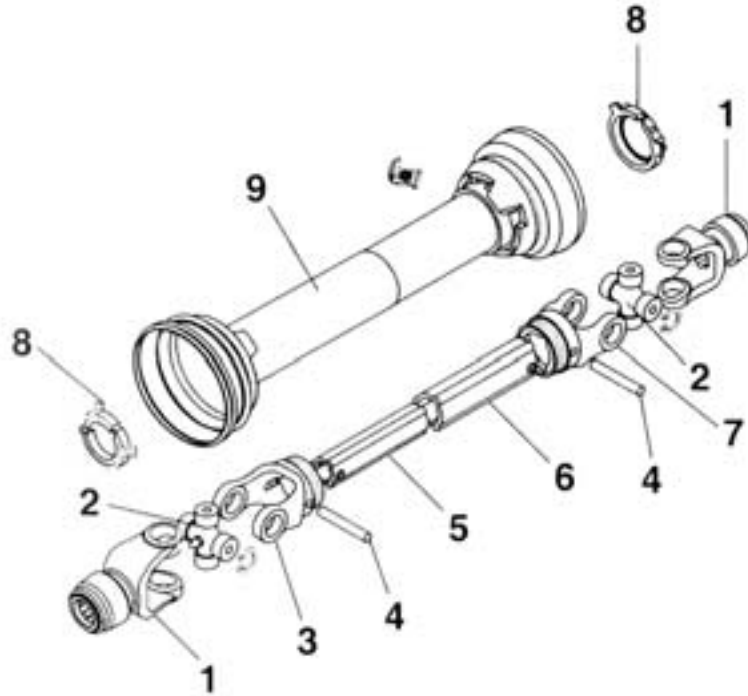

<u>REF#</u>	<u>QTY.</u>	<u>PART NO.</u>	<u>DESCRIPTION</u>
1	2	400.421638	Yoke Auto Lock
2	2	201-8474	Cross and Bearing Kit
3	1	410.400236	Yoke Inner Tube
4	2	795.0865	Spring Pin 8 x 65
5	1	710.364	Inner Tube
6	1	710.433	Outer Tube
7	1	410.400243	Yoke Outer Tube
8	2	961-2543	Bearing Kit
9	1	900-2560	Shield Kit
	1	13006500	Safety Chain Kit (Not Shown)
	1	ZB4071638	Complete Driveline Assembly

Please specify driveline manufacturer when ordering parts.

LIMITED WARRANTY



GEARMORE, INC., warrants each new Gearmore product to be free from defects in material and workmanship for a period of twelve (12) months from date of purchase to the original purchaser. This warranty shall not apply to implements or parts that have been subject to misuse, negligence, accident, or that have been altered in any way.

Our obligation shall be limited to repairing or replacement of any part, provided that such part is returned within thirty (30) days from date of failure to Gearmore through the dealer from whom the purchase was made, transportation charges prepaid.

This warranty shall not be interpreted to render us liable for injury or damages of any kind or nature, direct, consequential or contingent, to person or property. This warranty does not extend to loss of crops, loss because of delay in harvesting or any other expenses, for any other reasons.

Gearmore in no way warrants engines, tires, or other trade accessories, since these items are warranted separately by these respective manufacturers.

Gearmore reserves the right to make improvements in design or changes in specification at any time, without incurring any obligations to owners or units previously sold.

GEARMORE, INC.
13477 Benson Ave.
Chino, CA 91710

Always refer to and heed machine operating warning decals on machine.

The serial number of this product is stored in our computer database, thus submitting a warranty registration card is not required.