



# **HAMMER KNIFE FLAIL MOWER SHREDDER**

**Operation & Service  
Manual For Models:  
GCF41, 45, 53, 61,  
69, & 79**

**December 2007**



# TABLE OF CONTENTS

Installation .....	1
Safety Information .....	2
Lubrication .....	3
Pre-operation Check List .....	4
Mower Adjustments .....	5-6
Roller Height Control .....	7
Drive Belt Tension Adjustment .....	8
Troubleshooting & Safety Precautions .....	9
GCF Deck Assembly .....	10-11
GCF A-Frame Assembly .....	12
GCF Rake Hatch Assembly .....	13
GCF41-61 Rotor Assembly .....	14
GCF69-79 Rotor Assembly .....	15
Rotor Assembly .....	16-17
Quantity Matching Table .....	18
GCF Roller Assembly .....	19-20
GCF Drive Assembly .....	21-24
GCF41-61 Gearbox Assembly .....	25
GCF69-79 Gearbox Assembly .....	26
GCF41-61 PTO Shaft (Bondioli & Pavesi) .....	27
GCF69-79 PTO Shaft (Bondioli & Pavesi) .....	28
GCF41-61 PTO Shaft (Weasler) .....	29
GCF69-79 PTO Shaft (Weasler) .....	30
Limited Warranty .....	31

Date of Purchase: \_\_\_\_\_

Model Number: \_\_\_\_\_

Serial Number: \_\_\_\_\_

# INSTALLATION

## BEFORE ATTACHING THE MOWER TO THE TRACTOR

1. Make sure that the mower is suitable for your tractor's horsepower.

<u>MODELS</u>	<u>YOUR TRACTOR'S MAX. H.P.</u>
---------------	-------------------------------------

All

72



**CAUTION:** Please note that if these limits are exceeded, it will invalidate your warranty.

2. Make sure the lower links and top link on the 3-point hitch arms of your tractor are the correct size (Cat. I), so that they correspond to the size of the hitch on the mower you have purchased.

3. *P.T.O. Installation:*

First, connect the P.T.O. shaft to the tractor. With the shaft in its shortest position, there should be about a 2" clearance between the end of the gearbox shaft and the end of the P.T.O. shaft. Should it be necessary to shorten the P.T.O. shaft, shorten both male and female shafts equally, keeping the protective tube covers 1" shorter than the steel tubes.

Particular attention should be given to carefully removing all burrs and to clean and lubricate the steel tubes and protective covers. There must be sufficient telescopic movement so that the two tubes do not touch the end of the P.T.O. shaft.

It is most important to carefully raise and lower the mower with the tractor hydraulic system, making sure that the P.T.O. shaft does not bottom or disengage the telescopic shaft tubes, otherwise damage may occur.

# SAFETY INFORMATION



## OPERATIONAL SAFETY:

- ❑ Guards and safety shields are for your protection. **DO NOT** operate equipment unless they are in place.
- ❑ Always operate tractor PTO (power-take-off) at recommended RPM (revolutions per minute).
- ❑ Disengage tractor PTO and shift into neutral before attempting to start engine.
- ❑ Read and observe all safety decals on the tractor and mower.
- ❑ **NEVER** allow anyone within 25' of machine while it is in operation.
- ❑ **DO NOT** stop or start suddenly when going uphill or downhill. Avoid operation on steep slopes.
- ❑ Be alert for holes in terrain and other hidden hazards. Always drive slowly over rough ground.
- ❑ Reduce speed on slopes and in sharp turns to prevent tipping or loss of control. Be careful when changing direction on slopes.
- ❑ Stop mower and tractor immediately upon striking an obstruction. Turn off engine, inspect mower and repair any damage before resuming operation.
- ❑ Disengage power to mower and stop engine before dismounting from tractor, before making any repairs or adjustments, transporting or unclogging mower.
- ❑ Take all possible precautions when leaving tractor unattended: Disengage PTO, lower mower, shift into neutral, set parking brake, stop engine and remove key from ignition.
- ❑ Front tractor weights or front tire ballast should be used to enhance front end stability on small tractors.
- ❑ Check to make sure PTO is properly connected and that the driveline is correct to prevent bottoming out or pulling apart during the full lift range of the hitch.
- ❑ This implement is designed for a one-man operation. It is the responsibility of the tractor operator to see that no one is in the proximity of the implement when it is started. **DO NOT** operate the implement with another person within 25' of the implement.
- ❑ **NEVER** operate mower with hatch in the wrong working position.
- ❑ **NEVER** run mower with rotorshaft out of balance.

# LUBRICATION

Grease all fittings according to the following schedule:

1. **ROLLER** - Grease at both ends *after 4 hours* of operation, until excess grease is visible (*Ref. 1*).
2. **CUTTING SHAFT** - Grease at both ends lightly *after 8 hours* of operation (*Ref. 2*). **DO NOT** over grease.
3. **P.T.O. SHAFT** - Male and female telescopic tubes and universal joints should be cleaned and greased monthly, or more frequently in extreme operating conditions.

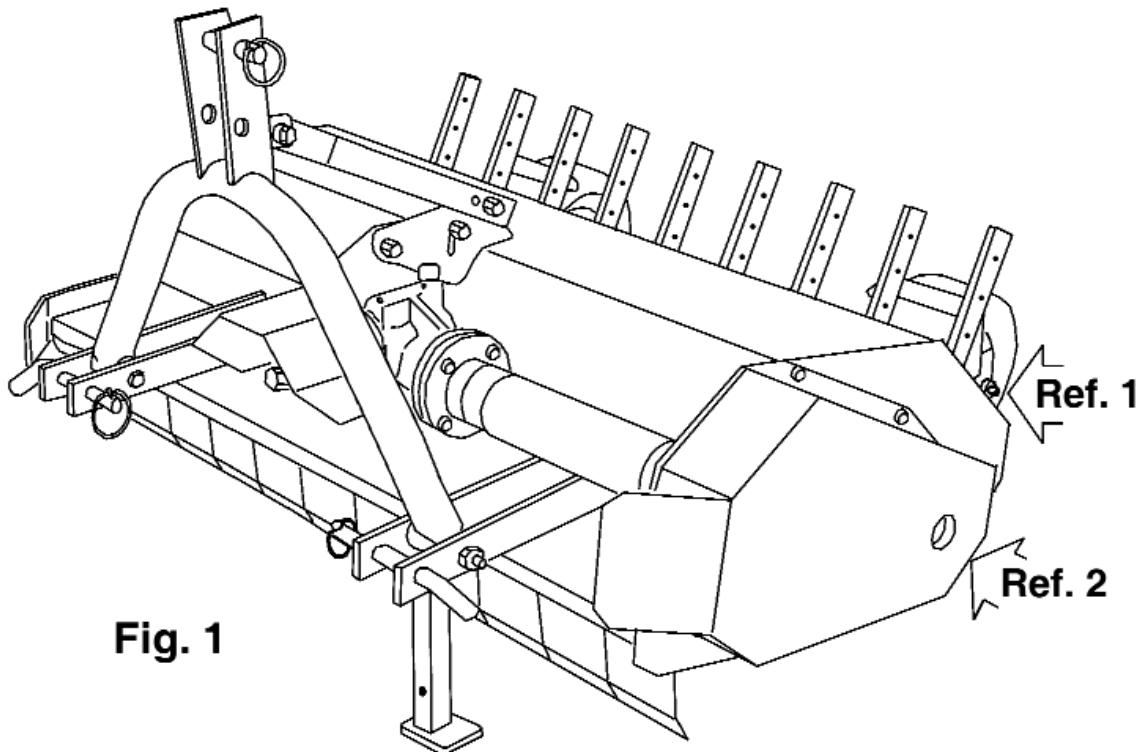

# PRE-OPERATION CHECK

- ✓ Check tightness of all bolts and nuts.
- ✓ Check gearbox oil level (Grade SAE80W-90 gear oil).
- ✓ Grease all points, on all GCF mowers.
- ✓ P.T.O. (power take-off) speed should not exceed 540 RPM (revolutions per minute).
- ✓ Check correct length of P.T.O. shaft. When fitted, there should be 3 3/4" free travel on male and female tubing (check in fully raised and fully lowered positions).
- ✓ The recommended cutting height, with the hammer or blade in its lowest position, is between 2" and 4" (Ref. 1). Basically, the fine height adjustment is achieved with the top link of the 3-point hitch. For a greater height adjustment, it is necessary to raise or lower the roller (Ref. 2).
- ✓ Drive belt should flex 3/8" (1 cm.) when pushed firmly with the finger.
- ✓ If your tractor does not have a double clutch, or has a hydraulic P.T.O., an overrunning P.T.O. shaft is required.
- ✓ Mower should be completely cleaned after use and before storage.

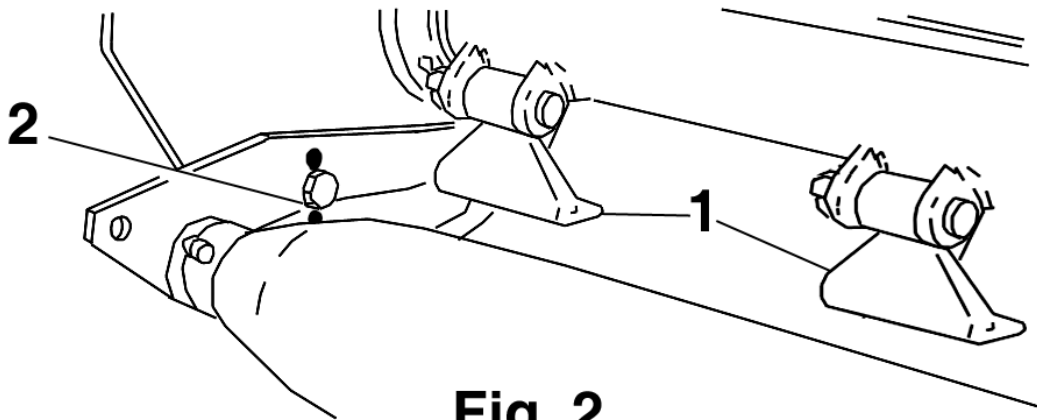

**Fig. 2**

# MOWER ADJUSTMENTS

## FOR VARIOUS TYPES OF MOWING

There is an adjustable rear hatch (Fig. 3) that can be set in one of seven positions to control the amount of power needed to do the work.

## FOR BEST MOWING OPERATION, OPEN REAR HATCH FULLY TO ALLOW MATERIAL TO EXIT

1. Adjustment of the rear hatch can be made by removing the two bolts at the side (Fig. 13, ref. 1). Loosen the nut (Fig. 13, ref. 2) until the hatch can be pivoted around bolt (Fig. 13, ref. 3). To fix the hatch in the desired position, align the hole in the side of the casing of the machine with the appropriate hole in the hatch. Insert the bolt and tighten the self-locking nut (Fig. 13, ref. 1). Tighten the pivot bolt (Fig. 13, ref. 3) with the self-locking nut (Fig. 13, ref. 2).
2. The rear hatch should be in a completely closed position (Fig. 4) when used for mulching of prunings, or pulverizing debris.
3. The hatch is used in position (Fig. 5) to allow the grass clippings to escape above the roller.
4. The hatch should be in a completely open position when the mower is used for grass, cover crop, weed abatement, vegetables, corn stalk and cotton cutting operations (Fig. 6). An open hatch enables the clippings to be discharged quickly, thus allowing a faster mowing speed and lower H.P. requirements.

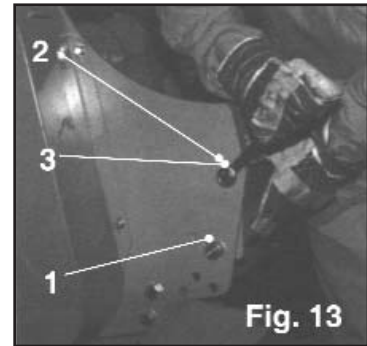

**DANGER:** When the hatch is in the fully open position, objects may be thrown out of the machine. Make sure that **NO ONE** is in the operation area.

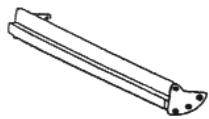

Fig. 3

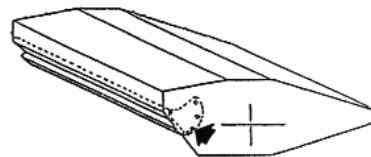

Fig. 4

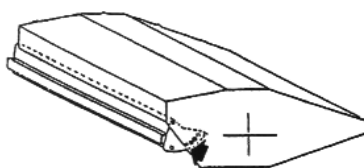

Fig. 5

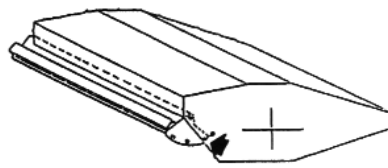
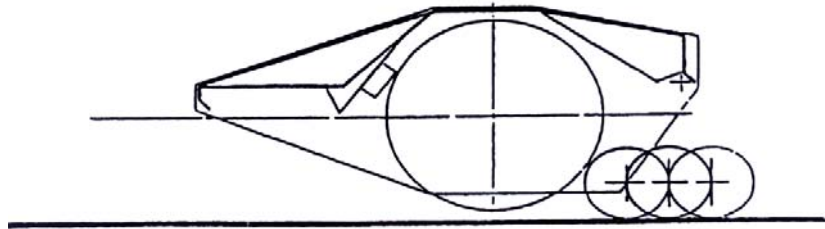

Fig. 6



# MOWER ADJUSTMENTS

1. Various roller adjustments  
3 positions



2. Used for mulching  
of prunings

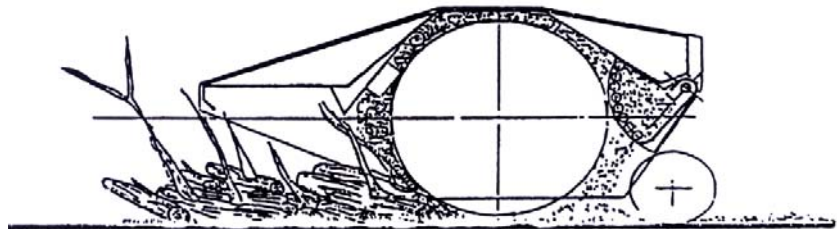

3. Used with rakes to  
mulch prunings

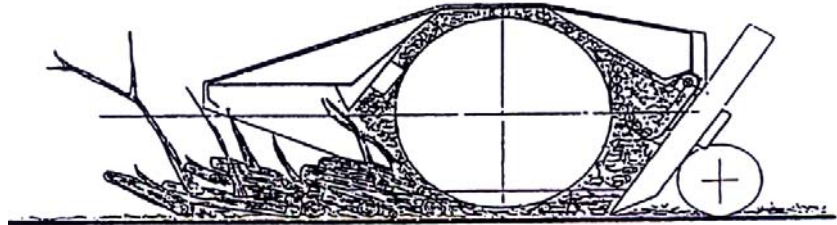

4. Used for cutting  
grass

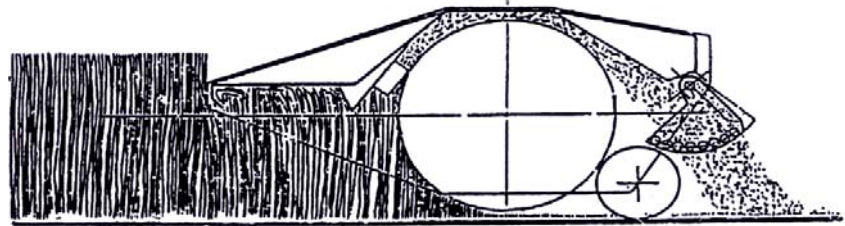

5. Used to mulch  
cornstalk

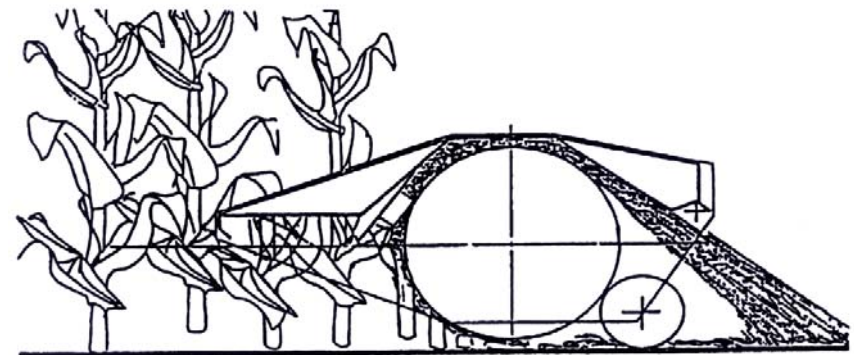

# ROLLER HEIGHT CONTROL

The roller can be adjusted for 2 or 3 cutting heights. By raising the roller, you get a shorter cut, by lowering it, a longer cut is achieved. You can also fine adjust the cutting height with the top link arm. By shortening the link arm, your cut is further from the ground.

A suggested cutting height is having the hammer tips about 2" from the ground.

You can control the power needed and the amount of wear on the hammers by this adjustment.

## ADJUSTING REAR ROLLER:

To adjust roller, loosen (*Fig. 1, ref. 1*). Completely remove (*Fig. 1, ref. 2 & 3*). Align the appropriate hole in the support bracket with the hole in the deck to achieve roller position desired.

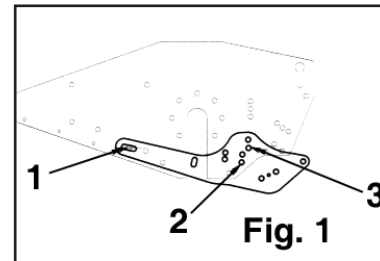

1. There is also an adjustment that can be made on the roller to control mulch size and power needed. By moving the roller toward the cutting shaft (*Fig. 7*), a finer mulch is produced, requiring less H.P. In this case, we suggest opening the hatch to cut grass, vegetables, cornstalk, cotton, etc.
2. By moving the roller away from the cutting shaft (*Fig. 7*), a coarser mulch is produced, requiring more H.P. In this case, we suggest closing the hatch to mulch prunings.
3. The third position, or furthest from the cutting shaft, is used only to allow room for rakes on the mower, if needed. Rakes are used when the prunings are laying close to the ground and have to be drawn out.
4. For more precise work and performance, we recommend spending 5 minutes adjusting your mower for the job, this can be done according to the previous recommendations.
5. The roller scraper can be removed when cutting grass, because close positioning of the roller to the cutting shaft permits the hammers to act as a roller cleaning device.

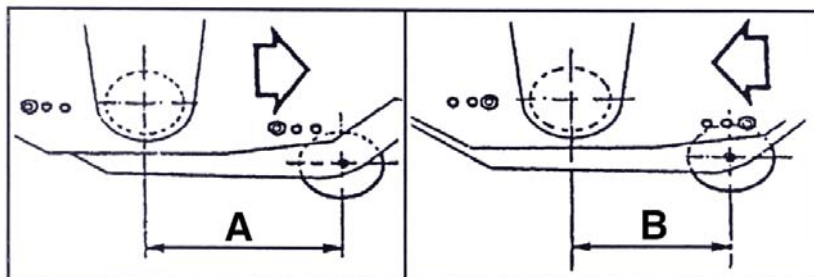
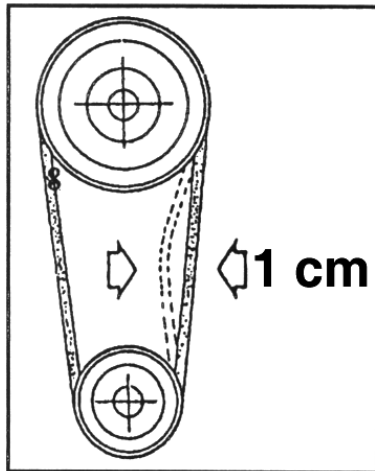

Fig. 7

# DRIVE BELT TENSION ADJUSTMENT

1. Check belt tension before each use (*Fig. 8*). The tension is correct when you can depress one belt 1 cm ( $3/8$ " ) between the two pulleys. It is possible for you to insert a tool through the belt cover (*Fig. 9*), with mower stopped, to check the tension.
2. To adjust the belt tension, loosen bolts 1, 2, 3 & 4 and locknut 6 (*Fig. 9*). To adjust tension, move bolt 5. Do not forget to tighten all bolts after correct belt tension is achieved. If a belt requires replacement, replace all other belts as well.



**Fig. 8**

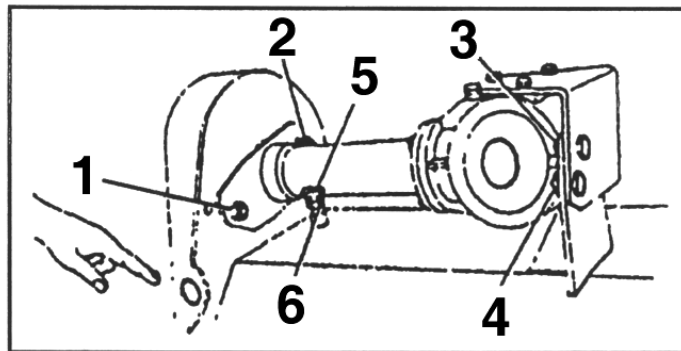

**Fig. 9**

# TROUBLESHOOTING

1. Cutting shaft does not rotate properly:
  - a. Tighten drive belts to correct tension (*see page 9*).
  - b. Replace belts if they no longer can be adjusted properly.
2. Mower vibrates:
  - a. Check for loose or missing hammers or bolts.
  - b. Check for hammers that are unevenly worn. If one or more hammers is badly worn, replace all the hammers the first time. Keep the hammers that are in good shape for future replacement in worn series of hammers. For example: when replacing a worn hammer, replace it with a hammer of similar shape and weight. This will insure a balanced and vibration free cutting.
3. If the cutting shaft becomes jammed, reverse the rotation of the shaft to loosen and release the obstruction.
4. If the hammer mounting ears break off, they must be welded back in their exact position, otherwise the cutting shaft will be unbalanced.
5. If you have any questions or problems, it is always best to contact your dealer immediately.
6. When ordering spare parts, you must contact your authorized Gearmore dealer for original replacement parts. When doing so, please include the following information:
  - a. Model Number
  - b. Serial Number

## SAFETY PRECAUTIONS

1. All adjustments, inspections and repairs must be made with tractor and mower completely stopped.
  - a. When the mower is in operation, make sure that there is no one near the flying debris from the mower, to prevent the possibility of serious injuries.
  - b. **ALWAYS** keep hands and feet away from a mower that is in operation.
  - c. Check that all guards and safety features are in place and in good operating condition.
2. While mowing, take the necessary precautions to insure operator's and others safety.
3. **DO NOT** make height adjustment using only the top link. This will cause flying debris to come out the front of the mower and toward the operator. Use the roller adjustment.

We thank you again for your choice of mowers and we remind you that the safety points outlined in this manual will help you do your work in a safe and efficient manner.

# GCF DECK ASSEMBLY

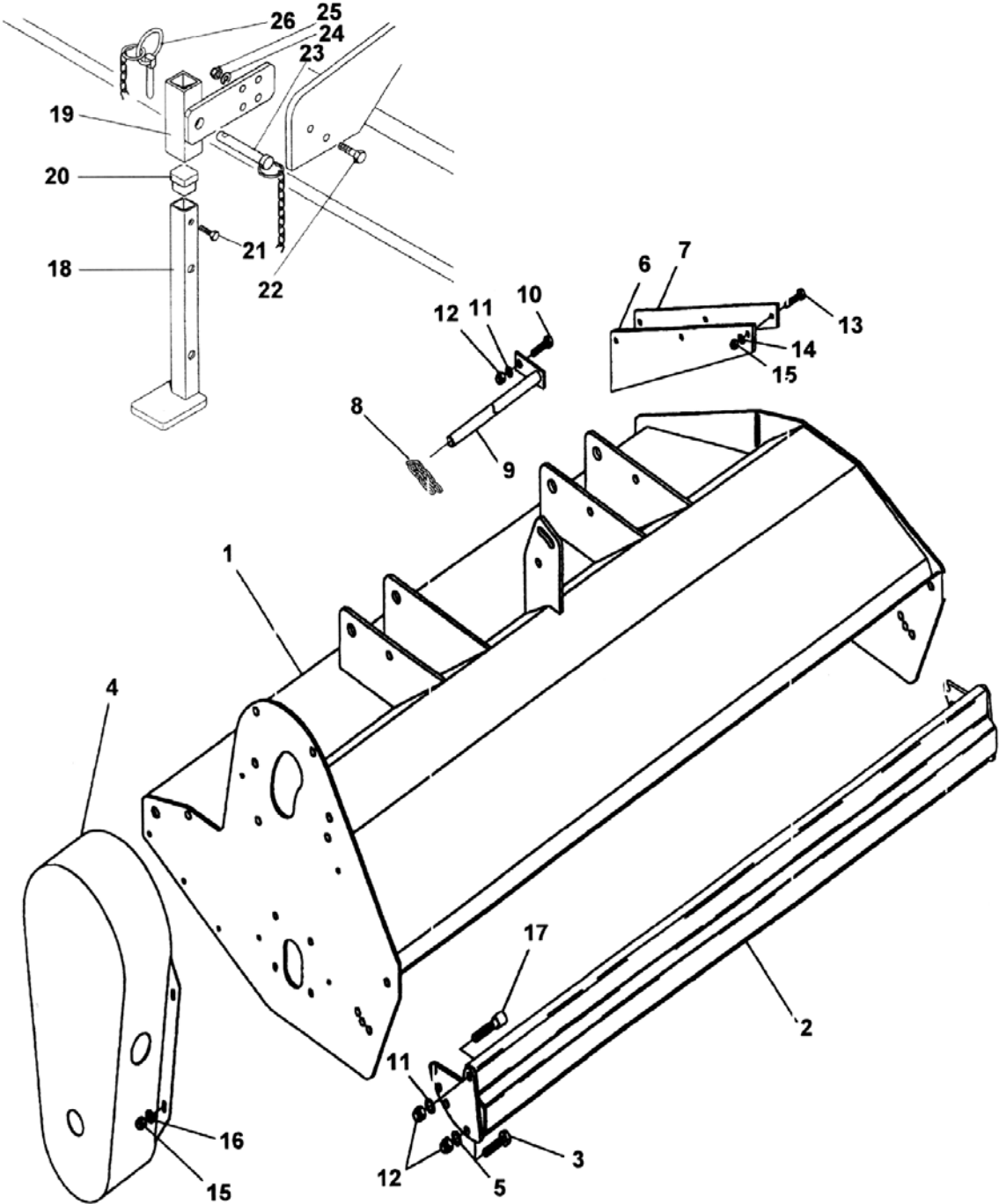

# GCF DECK ASSEMBLY

<u>REF#</u>	<u>QTY.</u>	<u>PART NO.</u>	<u>DESCRIPTION</u>
1	1	11001034	Deck Frame GCF41
1	1	11001035	Deck Frame GCF45
1	1	11001037	Deck Frame GCF53
1	1	11001038	Deck Frame GCF61
1	1	11001039	Deck Frame GCF69
2	1	15008022	Grass Hatch GCF41 (Optional)
2	1	15008023	Grass Hatch GCF45 (Optional)
2	1	15008025	Grass Hatch GCF53 (Optional)
2	1	15008026	Grass Hatch GCF61 (Optional)
2	1	13008019	Grass Hatch GCF69 (Optional)
3	2	96612421	Bolt M14 x 40
4	1	12010002	Belt Guard GCF41-61
4	1	12010003	Belt Guard GCF69 & 79
5	4	97495131	Washer M.15
6	1	13010033	Rubber Gasket
7	1	13010034	Side Plate
8	See Pg. 16	14310004	Deflector Chains From s/n 601100325
9	1	13010008	Shaft, Deflector Chain GCF41-69
9	1	13010012	Shaft, Deflector Chain GCF79
10	1	96612221	Bolt M14 x 30
11	1	97095511	Washer 15 x 28
12	1	97972321	Lock Nut M14
13	3	96605921	Bolt M8 x 40
14	3	97494831	Lock Washer M8
15	7	97971721	Lock Nut M8
16	4	97094911	Washer 8.4 x 16
17	2	96695723	Bolt M14 x 40
18	1	13011009	Parking Stand
19	1	11011001	Bracket
20	1	13011019	Cap, Plastic
21	1	97486611	Screw 6.3 x 19
22	2	96610021	Bolt M12 x 35
23	1	14311010	Pin
24	2	97495031	Lock Washer
25	2	97972031	Lock Nut
26	1	14311010	Lynch Pin

# GCF A-FRAME ASSEMBLY

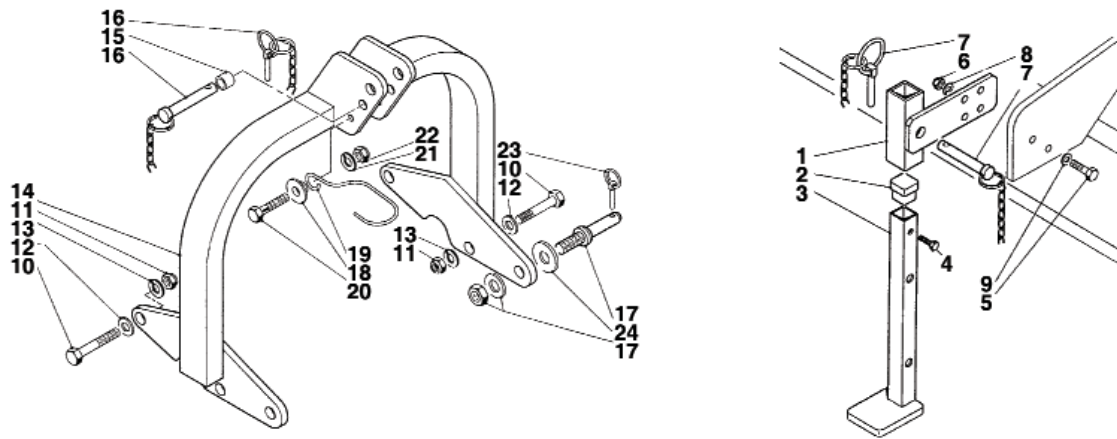

<u>REF#</u>	<u>QTY.</u>	<u>PART NO.</u>	<u>DESCRIPTION</u>
1	1	11011001	CPL Sleeve For Small Support
2	1	13011019	Cap F.Small Support QUIA 30 x 30
3	1	13011009	Support Foot
4	1	97486611	Bolt AUTOE. Type C 6.3 x 19 UNI 8117
5	1	96610021	Bolt TE M12 x 035 UNI 5739 8.8 ZN
6	1	97972021	Low Selfblock Nut M12-6S UNI 7474
7	1	14311010	Pin For Support (VS.COD. 33541)
8	1	97495034	Washer ELSP ASA B-27 12.2 x 21.2 x 2.5 N
9	1	97095311	Smooth Washer UNI 6592 12 x 24 x 2.5 ZN
10	1	96612721	Bolt TE M14 x 055 UNI 5739 8.8 ZN
11	1	97972321	Low Selfblock Nut M14-6S UNI 7474
12	1	97093311	Smooth Washer M14 UNI 5714 ZN
13	1	97495134	Washer ELSP ASA B-27 14.2 x 24.1 x 3 N
14	1	11004095	3-Point Linkage (Mod. 99) Prior to 2008
14	1	11004149	3-Point Linkage (Mod. 99) I & II Cat After 2008
15	1	13004060	Converter Bushing 25 x 2.5 x 50
16	1	19704005	Cat. I Pin 3° Point +Chain+Pin 19
17	1	13004147	Cat. I & II Pin 1° E 2° Point '96
17	1	16004020	Cat. I Pin 1° E 2° Point RIMA 33481
18	1	13004139	Boccola Per P.T.O. Shaft Support
19	1	14404021	P.T.O. Shaft Support
20	1	96609621	Bolt TE M12 x 050 UNI 5737 8.8 ZN
21	1	97495034	Washer ELSP ASA B-27 12.2 x 21.2 x 2.5 N
22	1	97972021	Low. Selfblock Nut M12-6S UNI 7474
23	1	16004014	Pin D.10
24	1	97096211	Smooth Washer UNI 6592 25 x 44 x 4.0 ZN

# RAKE HATCH ASSEMBLY

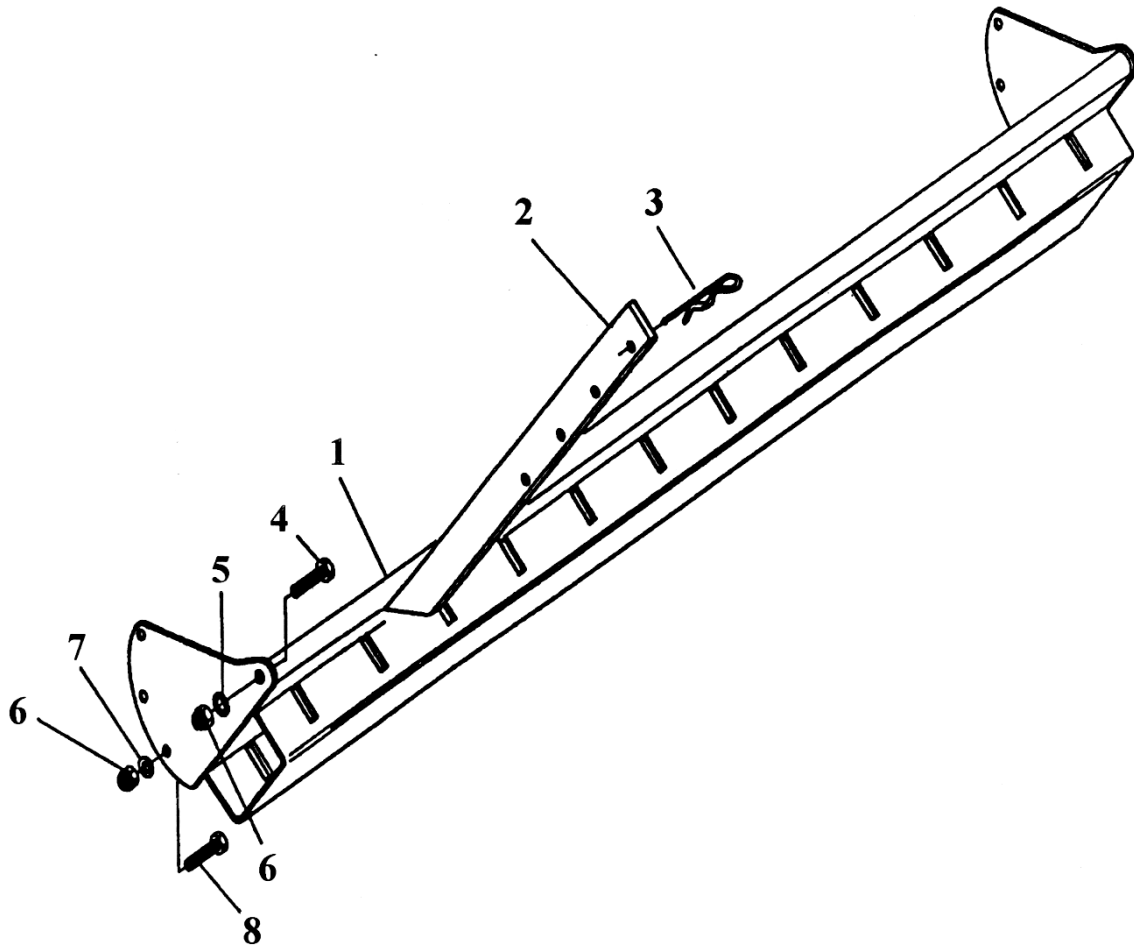

<u>REF#</u>	<u>QTY.</u>	<u>PART NO.</u>	<u>DESCRIPTION</u>
1	1	15008032	Rake Hatch GCF41
1	1	15008033	Rake Hatch GCF45
1	1	15008035	Rake Hatch GCF53
1	1	15008036	Rake Hatch GCF61
1	1	13008027	Rake Hatch GCF69
1	1	13008028	Rake Hatch GCF79
2	As Req'd	13008050	Rake 1/2 x 1-9/16 x 20
3	As Req'd	91009060	Hair Pin
4	2	96695723	Bolt M14 x 40
5	2	97095511	Washer 15 x 28
6	4	97972321	Lock Nut M14
7	2	97495131	Lock Washer
8	2	96612421	Bolt M14 x 40



# ROTOR ASSEMBLY GCF41-61

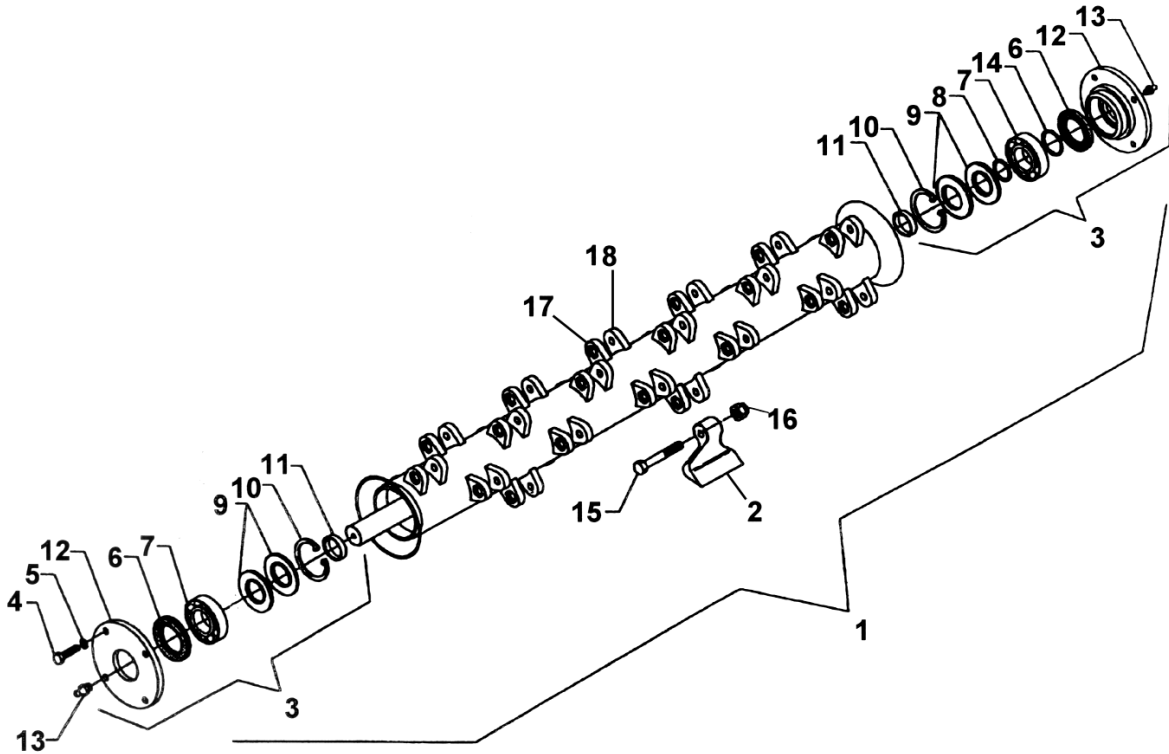

<u>REF#</u>	<u>QTY.</u>	<u>PART NO.</u>	<u>DESCRIPTION</u>
1	1	15002003	Complete Rotor Assy GCF41
1	1	15002004	Complete Rotor Assy GCF45
1	1	15002006	Complete Rotor Assy GCF53
1	1	15002007	Complete Rotor Assy GCF61
2	See Pg. 16	48020001	Flail Knife SMW
3	2	15002103	Rotor Support (Less Ref. 8, 11, & 14)
4	8	96609821	Bolt M12 x 25
5	8	97495031	Lock Washer
6	2	40x62x7	Oil Seal
7	2	22208	Bearing
8	2	98045516	Spacer 40 x 50 x 2.5
9	2	15002044	2 pcs. Metal Seal 40 x 80 x 6
10	2	47280	Circlip 80 x 2.5 Int.
11	2	15002046	Spacer
12	2	15002042	Support Hub
13	2	97036711	Grease Zerk M8
14	1	47140	Circlip 40 x 1.75 R.H. Only Ext.
15	See Pg. 16	13002075	Special Bolt M16 x 1.5 x 90
16	See Pg. 16	13002076	Special Lock Nut M16 x 1.5
17	See Pg. 16	15002039	Hex Ear Flail Knife
18	See Pg. 16	15002038	Ear Flail Knife

# ROTOR ASSEMBLY GCF69 & 79

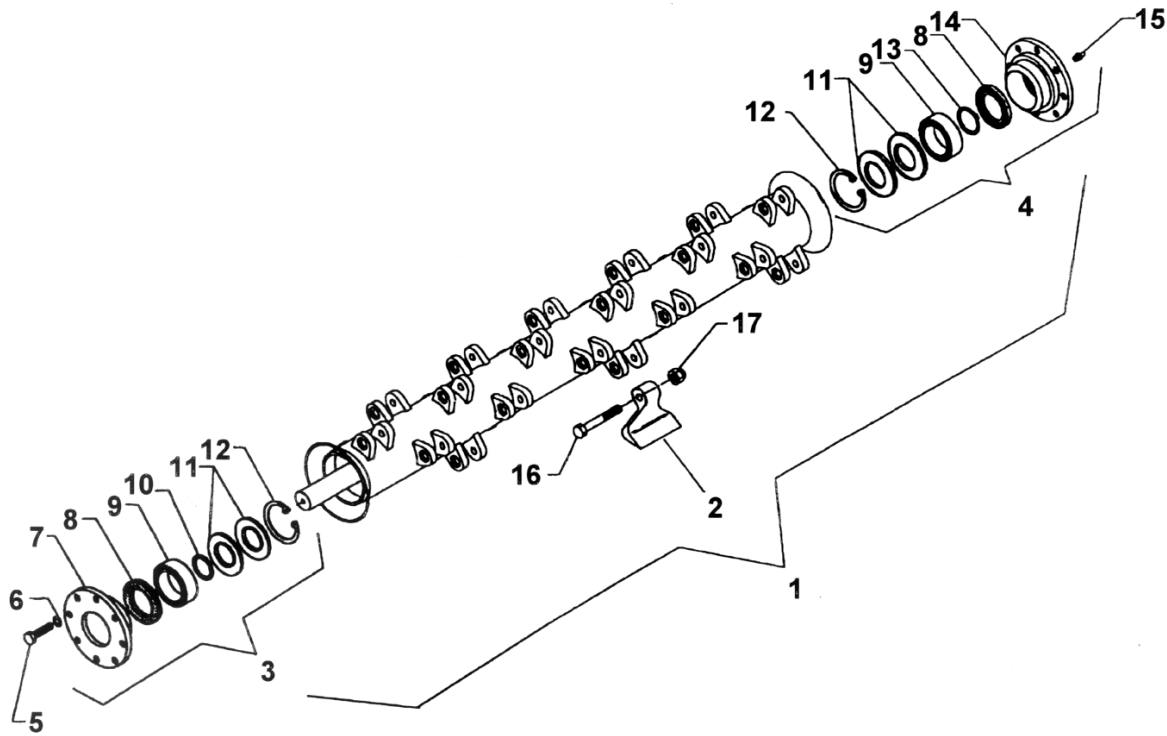

<u>REF#</u>	<u>QTY.</u>	<u>PART NO.</u>	<u>DESCRIPTION</u>
1	1	12002001	Complete Rotor Assembly GCF 69
1	1	12002002	Complete Rotor Assembly GCF 79
2	See Pg. 16	48020001	Flail Knife SMW
3	1	13002035	L.H. Rotor Support Assembly
4	1	13002034	R.H. Rotor Support Assembly
5	See Pg. 16	96612221	Bolt M14 x3 0
6	See Pg. 16	97495131	Lock Washer M14
7	1	13002014	Support Hub L.H.
8	2	50x90x10	Oil Seal
9	2	22209	Bearing
10	1	98045816	Spacer 45 x 55 x 2.5
11	2	13002037	2 pcs. Metal Seal 50 x 85 x 6
12	2	47285	Snap Ring 85 x 3 Int.
13	1	96867676	Circlip 45 x 1.75 R.H. Only
14	1	13002013	Support Hub R.H.
15	2	97036711	Grease Zerk
16	See Pg. 16	13002075	Special Bolt M16 x 1.5 x 90
17	See Pg. 16	13002076	Special Lock Nut M16 x 1.5

# ROTOR ASSEMBLY

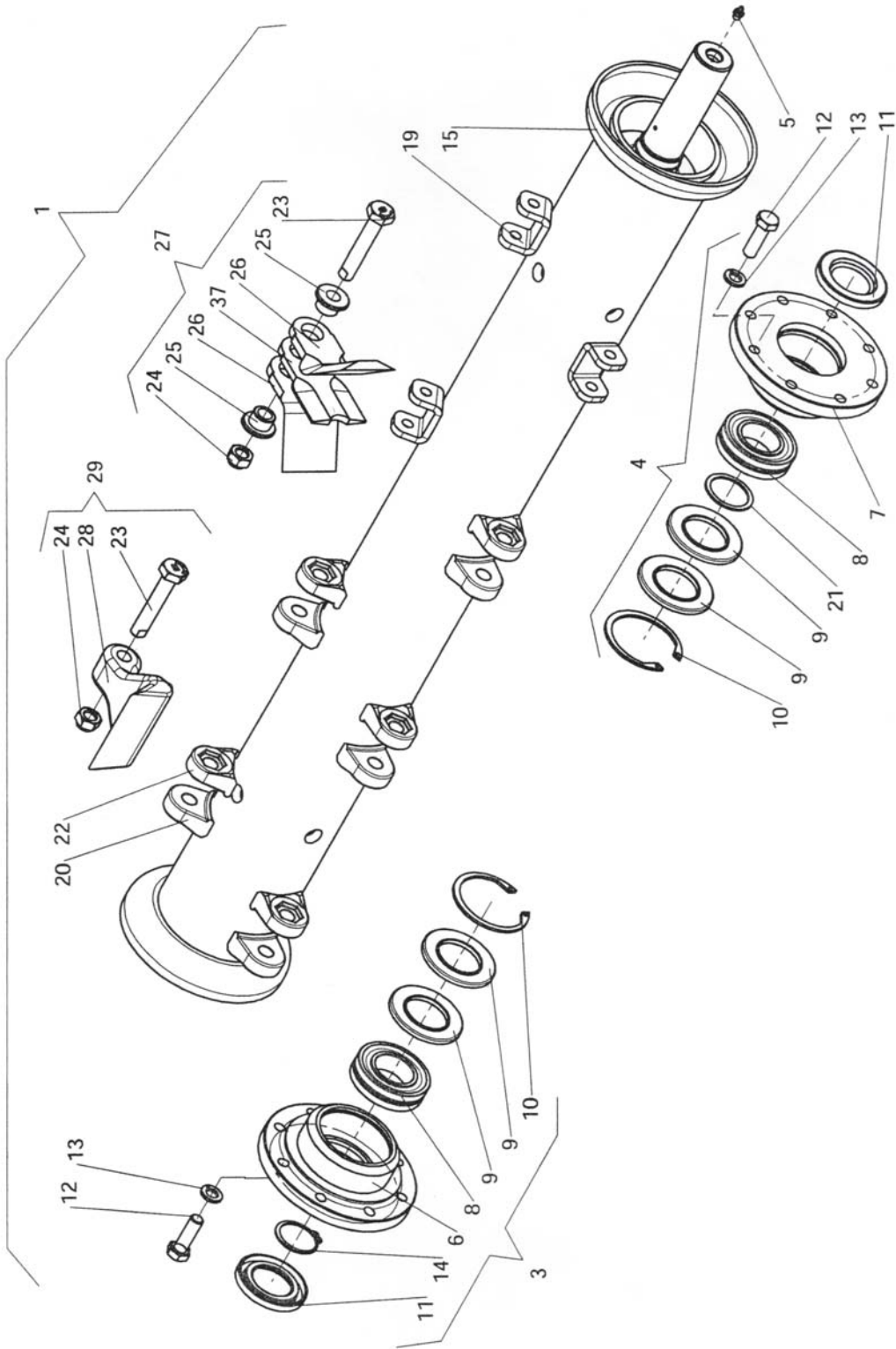

# ROTOR ASSEMBLY

<u>REF#</u>	<u>QTY.</u>	<u>PART NO.</u>	<u>DESCRIPTION</u>
1	1	12002001	Rotor Group (L=175)
1	1	12002002	Rotor Group (L=200)
1	1	12002005	Rotor Group w/flails "SMW" (L=175)
1	1	12002006	Rotor Group w/flails "SMW" (L=200)
1	1	12002009	Rotor Group w/flails f/Shakel L=175
1	1	12002010	Rotor Group w/flails f/Shakel L=200
1	1	15002195	Gruppo Rotore SMW-FORST 175
1	1	15002196	Gruppo Rotore SMW-FORST 200
2		48020004	Hammer SMW-FORST Double Sided
3		13002034	CPL Support with Rabbet D.085
4		13002035	CPL Support without Rabbet D.085
5		97036711	Grease Nipple UNI 7663 AM M8X1.25
6		13002013	Support D.085 with Rabbet
7		13002014	Support D.085 no Rabbet
8		13002041	Revolving Roller Bearing 22209 E
9		13002037	Labyrinth 50/85/6
10		96874976	Elastic Ring for Holes 85x3
11		13002047	Oil Seal 45 x 80 x 10
12		96612227	Bolt TE M 14 x 030 UNI 5739 8.8 Black
13		97495131	Washer ELSP ASA B-27-14.2x24.1x3 ZN
14		96867676	El. Ring F/Shafts 45 x 1.75
15		13002102	Protection Cap D=125 (L=125-200)
16		15002202	Barra Rotore SMW-FORST 200
18		97971721	Low. Self Block Nut M 8-6S UNI 7474
19		21002005	Supporto Per Grillo Portalame SP.10
20		15002038	Smooth Flail Knife Ear
21		98045816	Spacer 45 055 x 2
22		15002039	Flail Knives Ears w/Hexagonal Seat
23		13002075	Special Bolt M16 x 1.5 x 90 10.9
24		13002076	Special Nut M16 x 1.5-10.9
25		13002044	Boccola Per 3 Lame (SP. 10-8-10)
26		15002048	Flail Replacing Hammer for SMW
27		48020009	CPL. Kit Flails Replacing Hammers SMW
28		15002041	Hammer SMW/A/O85-155 SMO/WM 225-275
29		48020001	CPL. Kit Hammer SMW (Nut + Bolt)
37		15002256	Center Blade

# QUANTITY MATCHING CHART

PART NO.	DESCRIPTION	MODELS					
		GCF41	GCF45	GCF53	GCF61	GCF69	GCF79
14310004	Deflector Chain	29	32	40	48	56	64
48020001	Flail Knife	9	12	12	15	18	21
13002075	Bolt, Knife	9	12	12	15	18	21
13002076	Lock Nut, Knife	9	12	12	15	18	21
15002039	Hex Knife Ear	9	12	12	15	18	21
15002038	Knife Ear	9	12	12	15	18	21

# ROLLER ASSY (Prior to s/n 701100007)

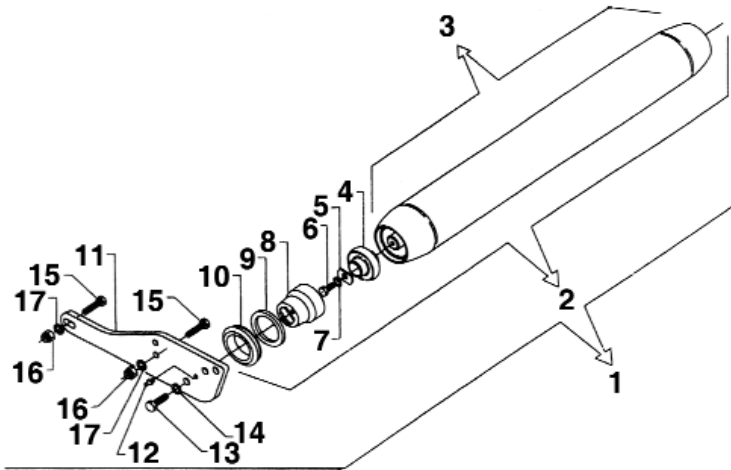

<u>REF#</u>	<u>QTY.</u>	<u>PART NO.</u>	<u>DESCRIPTION</u>
1	1	11005004	Roller Assy. w/Bearings GCF41
1	1	11005005	Roller Assy. w/Bearings GCF45
1	1	11005007	Roller Assy. w/Bearings GCF53
1	1	11005008	Roller Assy. w/Bearings GCF61
1	1	11005009	Roller Assy. w/Bearings GCF69
1	1	13005005	Roller Assy. w/Bearings GCF79
2	1	11005021	Roller w/Bearings GCF41
2	1	11005022	Roller w/Bearings GCF45
2	1	11005024	Roller w/Bearings GCF53
2	1	11005025	Roller w/Bearings GCF61
2	1	11005026	Roller w/Bearings GCF69
2	1	71114200	Roller w/Bearings GCF79
3	1	11005029	Roller GCF41
3	1	11005030	Roller GCF45
3	1	11005032	Roller GCF53
3	1	11005033	Roller GCF61
3	1	11005034	Roller GCF69
3	1	13005019	Roller GCF79
4	2	UC207-35	Bearing
5	2	11005061	Washer 48 x 25 x 5
6	2	96607521	Bolt M10 x 20
7	2	97494931	Lock Washer M10
8	2	11005035	Bearing Support
9	2	11005065	Labyrinth 70/92/5
10	2	11005071	Bushing
11	2	11005037	Roller Support
12	2	97036711	Grease Zerk 8 x 5.8
13	4	96612221	Bolt M14 x 30
14	4	97495131	Lock Washer M15
15	6	96610021	Bolt M12 x 35
16	6	97972021	Lock Nut M12
17	6	97495031	Lock Washer M13

# ROLLER ASSY (After s/n 701100007)

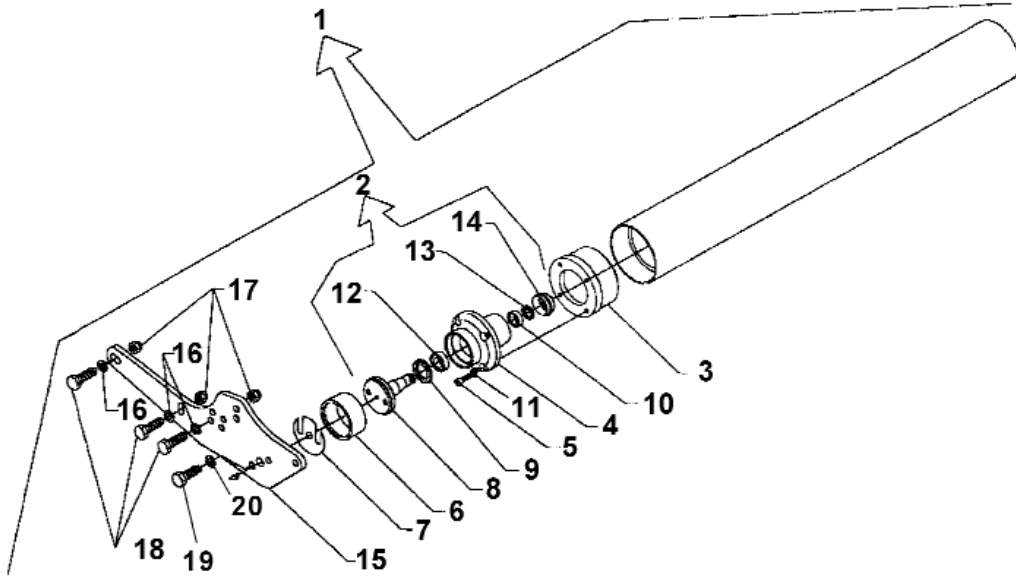

<u>REF#</u>	<u>QTY.</u>	<u>PART NO.</u>	<u>DESCRIPTION</u>
1	1	11005104	Complete Roller Assembly GCF41
1	1	11005105	Complete Roller Assembly GCF45
1	1	11005107	Complete Roller Assembly GCF53
1	1	11005108	Complete Roller Assembly GCF61
1	1	11005109	Complete Roller Assembly GCF69
1	1	11005110	Complete Roller Assembly GCF79
2	2	13005000	Hub Assembly
3	2	13005163	Bearing Hub Support Weld-on
4	2	13005160	Hub
5	8	96692223	Bolt M10 x 30
6	2	13005165	Spacer
7	As Req'd	11005069	Shim 0.5 mm
7	As Req'd	11005068	Shim 1.0 mm
8	2	13005143	Axle
9	2	58X72X8	Oil Seal
10	2	30205	Bearing
11	8	97494934	Washer D.10
12	2	32207	Bearing
13	2	13005088	Nut M25 x 1.5
14	2	13005162	Dust Cap
15	2	11005037	Roller Support
16	8	97495031	Washer
17	8	97972021	Lock Nut M12
18	8	96610021	Bolt M12 x 30
19	4	96612221	Bolt M14 x 30
20	4	97495131	Washer M15

# GCF DRIVE ASSEMBLY GCF41-61

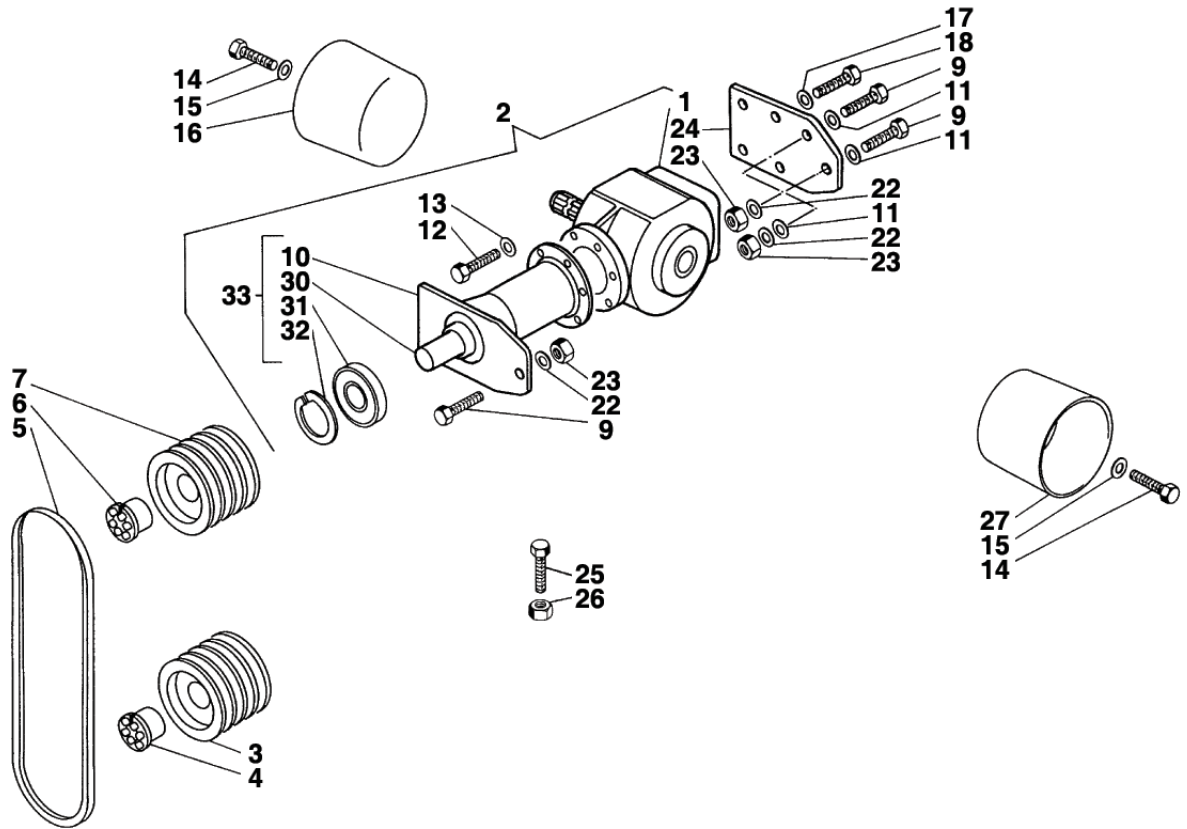

<u>REF#</u>	<u>QTY.</u>	<u>PART NO.</u>	<u>DESCRIPTION</u>
1	1	11203025	Gearbox Box TL 311 (9.311.781.00) RL AP 1/
1	1	12003006	Gearbox Box TL 311 (9.311.780.00) RL R=1:3
2	1	11003005	Gear TL 311 R1:3 LP=170 (N. Cross. SH)
2	1	11003006	Gear TL 311 R1:3 LP=240 (N. Cross. SH)
2	1	11003015	Gear TL 311 R1:3 LP=270 (N. Cross. SH)
2	1	11003016	Gear TL 311 R1:3 LP=320 (N. Cross. SH)
2	1	11003017	Gear TL 311 R1:3 LP=370 (N. Cross. SH)
2	1	11003018	Gear TL 311 R1:3 LP=420 (N. Cross. SH)
2	1	11003019	Gear TL 311 R1:3 LP=520 (N. Cross. SH)
2	1	11003030	Gear TL 311 A. Pass R1:3 LP=520
2	1	15003070	Gear TL 311 R1:3 LP=470 (N. Cross. SH)
2	1	15003071	Gear TL 311 R1:3 LP=620 (N. Cross. SH)
3	1	15003056	Pulley 3SPB 140
4	1	15003054	Taper Lock Viblock VK 156 40 x 80 Std.
5	3	12003001	Belt BX43
6	1	13003005	Taper Lock Viblock VK 156 35 x 80
7	1	15003055	Pulley 3SPB 180



# GCF DRIVE ASSEMBLY GCF41-61

<u>REF#</u>	<u>QTY.</u>	<u>PART NO.</u>	<u>DESCRIPTION</u>
9	3	96612421	Bolt TE M14 x 040 UNI 5739 8.8 ZN
10	1	11003001	Ext. Sh. DA170
10	1	11003002	Ext. Sh. DA240
10	1	15003018	Ext. Sh. DA270
10	1	15003019	Ext. Sh. DA320
10	1	15003020	Ext. Sh. DA370
10	1	15003021	Ext. Sh. DA420
10	1	15003022	Ext. Sh. DA470
10	1	15003023	Ext. Sh. DA520
10	1	15003024	Ext. Sh. DA620
11	1	97093311	Smooth Washer M14 UNI 5714 ZN
12	1	96610027	Bolt TE M12 x 035 UNI 5739 8.8 Black
13	1	97495034	Washer ELSP ASA B-27-12.2 x 21.2 x 2.5 N
14	4	96605321	Bolt TE M08 x 012 UNI 5739 8.8 ZN
15	4	97094921	Smooth Washer M8 9 x 24 x 2 ZN
16	1	14310012	Circular Protection (30/211)
17	4	97495034	Washer ELSP ASA B-27 12.2 x 21.2 x 2.5 N
18	4	96609827	Bolt TE M12 x 025 UNI 5739 8.8 Black
22	3	97495134	Washer ELSP ASA B-27 14.2 x 24.1 x 3 N
23	3	97972321	Low Self Block Nut M14-6S UNI 7474
24	1	11003014	Plate F.Gearbox 6 mm
24	1	13003467	Plate
25	1	96610121	Bolt TE M12 x 040 UNI 5739 8.8 ZN
26	1	96979971	Nut M12-6SS UNI 5589 BASSO H=07
30	1	11003007	CPL. Shaft L=215
30	1	11003008	CPL. Shaft L=285
30	1	15003026	CPL. Shaft L=315
30	1	15003027	CPL. Shaft L=365
30	1	15003028	CPL. Shaft L=415
30	1	15003029	CPL. Shaft L=465
30	1	15003030	CPL. Shaft L=515
30	1	15003031	CPL. Shaft L=565
30	1	15003032	CPL. Shaft L=665
31	1	15003052	Bearing 6208 2RS1 40 x 80 x 18
32	1	96867476	El. Ring F.Shafts 40 x 1.75
33	1	11003011	CPL Ext. Shaft DA170
33	1	11003012	CPL Ext. Shaft DA240
33	1	15003008	CPL Ext. Shaft DA270
33	1	15003009	CPL Ext. Shaft DA320
33	1	15003010	CPL Ext. Shaft DA370
33	1	15003011	CPL Ext. Shaft DA420
33	1	15003012	CPL Ext. Shaft DA470
33	1	15003013	CPL Ext. Shaft DA520
33	1	15003014	CPL Ext. Shaft DA620

# GCF DRIVE ASSEMBLY GCF69-79

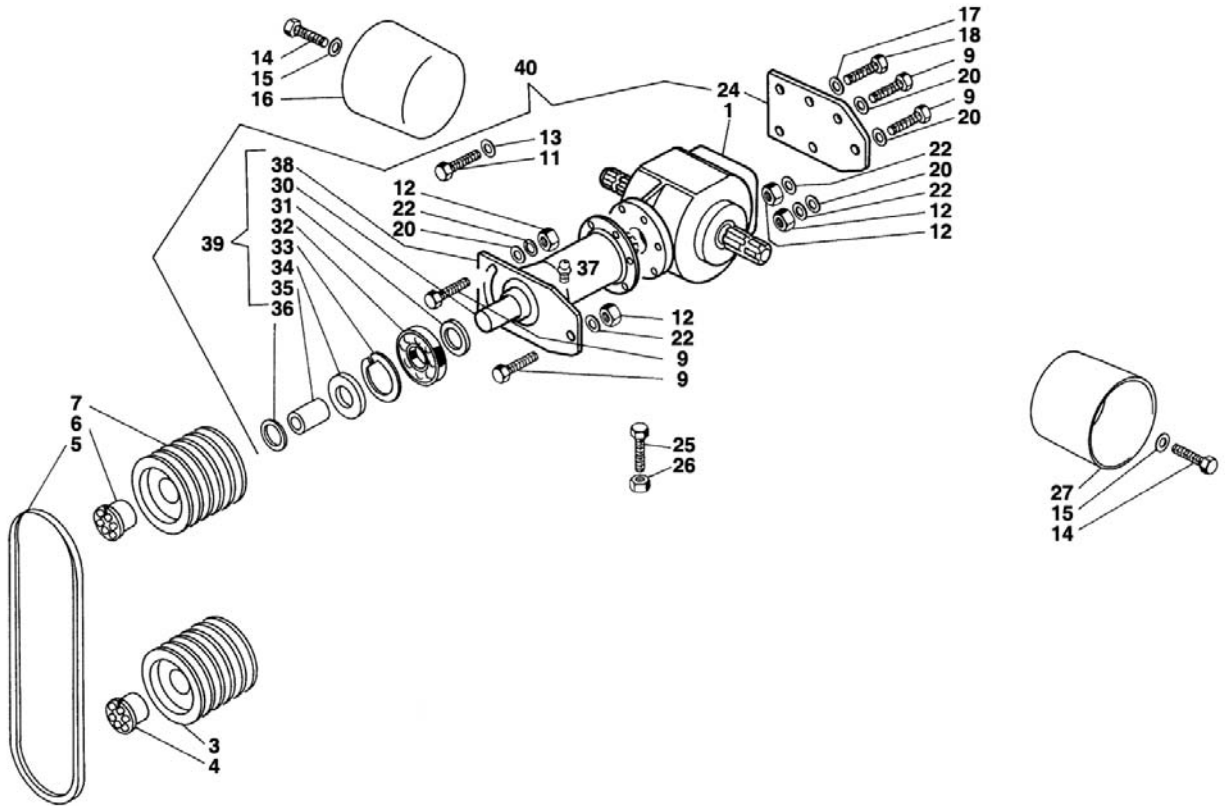

<u>REF#</u>	<u>QTY.</u>	<u>PART NO.</u>	<u>DESCRIPTION</u>
1	1	48030942	Gearbox Box TL 311 (9.311.784.00) RL AP R2
1	1	48030943	Gearbox Box TL 311 (9.311.785.00) RL R=1:2
3	1	13003012	Pulley 4SPB 160
4	1	13003006	Taper Lock Viblock VK156 45 x 80
4	1	15003054	Taper Lock Viblock VK156 40 x 80 Std.
5	1	48030761	Belt BX49
6	1	13003005	Taper Lock Viblock VK165 35 x 80
7	1	75000307	Pulley 4SPB 250
9	1	96612421	Bolt TE M14 x 040 UNI 5739 8.8 ZN
11	1	96610027	Bolt TE M12 x 035 UNI 5739 8.8 Black
12	1	97972321	Low Selfblock Nut M14-6S UNI 7474
13	1	97495034	Washer ELSP ASA B-27 12.2 x 21.2 x 2.5 N
14	1	96605321	Bolt TE M08 x 012 UNI 5739 8.8 ZN
15	1	97094921	Smooth Washer M8 9 x 24 x 2 ZN
16	1	14310012	Circular Protection (30/211)
17	1	97495034	Washer ELSP ASA B-27 12.2 x 21.2 x 2.5 N
18	1	96609827	Bolt TE M12 x 025 UNI 5739 8.8 Black
20	1	97093311	Smooth Washer M14 UNI 5714 ZN

# GCF DRIVE ASSEMBLY GCF69-79

<u>REF#</u>	<u>QTY.</u>	<u>PART NO.</u>	<u>DESCRIPTION</u>
22	1	97495134	Washer ELSP ASA B-27 14.2 x 24.1 x 3 N
24	1	13003003	Plate F.Gearbox
24	1	13003467	Plate
25	1	96610121	Bolt TE M12 x 040 UNI 5739 8.8 ZN
26	1	96979971	Nut M12-6S UNI 5589 BASSO H=07
30	1	13003206	CPL. Shaft L=790 TL 311 Key
30	1	13003304	CPL. Shaft L=645 TL 311 Key
30	1	13003320	CPL. Shaft L=915 TL 311 Key
31	1	48030085	Oil Seal 45 x 72 x 10
32	1	19403058	Bearing 22208 E 40/80/23
33	1	96874776	El. Ring F.Holes 80 x 2.5
34	1	48030181	Oil Seal 50 x 80 x 10
35	1	13003310	Spacer F.Ext. Shaft TL311
36	1	13003290	Spacer L=20
37	1	97036611	Grease Nipple UNI 7663 AM 6-5.8
38	1	13003203	Ext. Sh. L=710 x TL 311
38	1	13003305	Ext. Sh. L=565 x TL 311
38	1	13003312	Ext. Sh. L=835 x TL 311
39	1	13003308	CPL Ext. Sh. L=710 x TL 311
39	1	13003309	CPL Ext. Sh. L=565 x TL 311
39	1	13003313	CPL Ext. Sh. L=835 x TL 311
40	1	11003050	Gear. TL 311 1:2,54 LP=565 (No Cr. Shaft)
40	1	11103002	Gear. TL 311 A.Pass. 1:2,54 LP=565
40	1	13003427	Gear. TL 311 1:2,54 LP=710 (No Cr. Shaft)
40	1	13003428	Gear. TL 311 1:2,54 LP=835 (No Cr. Shaft)
40	1	13003443	Gear. TL 311 A.Pass. 1:2,54 LP=710

# GCF GEARBOX ASSEMBLY GCF41-61

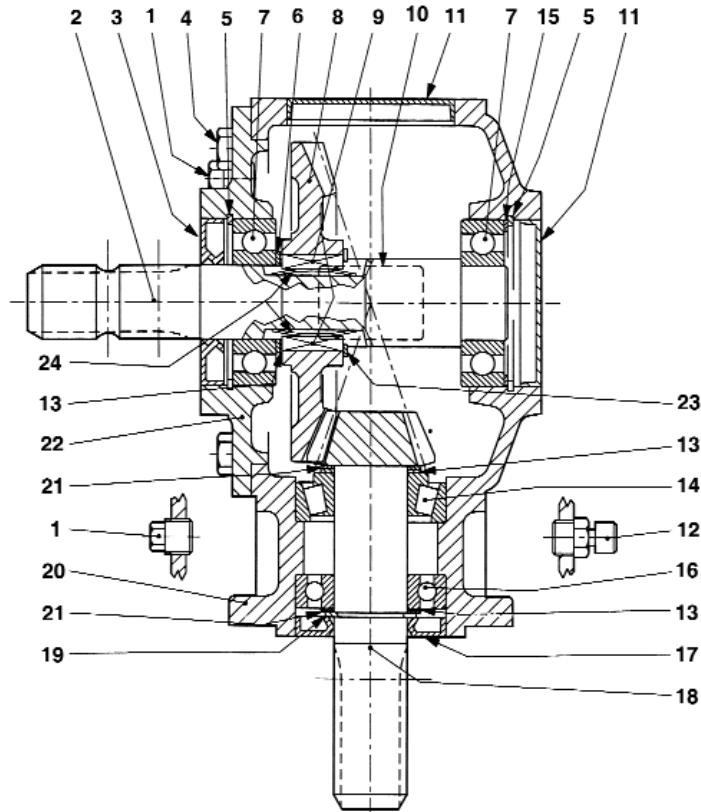

<u>REF#</u>	<u>QTY.</u>	<u>PART NO.</u>	<u>DESCRIPTION</u>
1	1	48030292	Plug
2	1	48030615	Spl. Shaft F.W. 1" 3/8 Z6 (0.311.3201.00)
3	1	10503016	Oil Seal 35 x 80 x 10
4	1	96607627	Bolt TE M10 x 025 UNI 5739 8.8 Black
5	1	96874776	El. Ring F.Holes 80 x 2.5
6	1	48030984	Spacer 35.3 x 48 x 1 (0.259.7510.00)
7	1	75000029	Bearing 6307 A SFERE
8	1	48030616	Taper Crown WH.Z 36 M5 (0.311.6200.00)
9	1	48030799	Feather For Free Wheel (0.267.7109.00)
11	1	48030267	Closing Cap 80 x 10 (8.7.0.00790)
12	1	48030003	Cap 3/8" G (8.6.7.00161) NPT
13	1	48030415	Spacer 48.0 x 35.3 x 0.3 (0.259.7503.00)
14	1	48030411	Bearing 32207 A RULLI CON.
15	1	48030884	Spacer 69.0 x 79.9 (0.267.7503.00)
16	1	36902003	Bearing 6207 35 x 72 x 17 Ball Bearing
17	1	48030180	Oil Seal 35 x 72 x 10
18	1	48030538	Pinion Shaft Z12 M4.35 (0.304.5015.00)
19	1	96864576	El. Ring F.Shafts 35 x 2.5
20	1	48030991	Gearbox T2 (0.311.0300.00)
21	1	48030535	Spacer 48.0 x 35.3 x 1.3 (0.259.7513.00)
22	1	48030992	Open Cover Prot. (0.311.1300.00) T2
23	1	48030982	El. Ring F. Shafts 42 (8.5.1.00712)
24	1	48030983	Spring For Free Wheel (0.267.7110.00)

# GCF GEARBOX ASSEMBLY GCF69-79

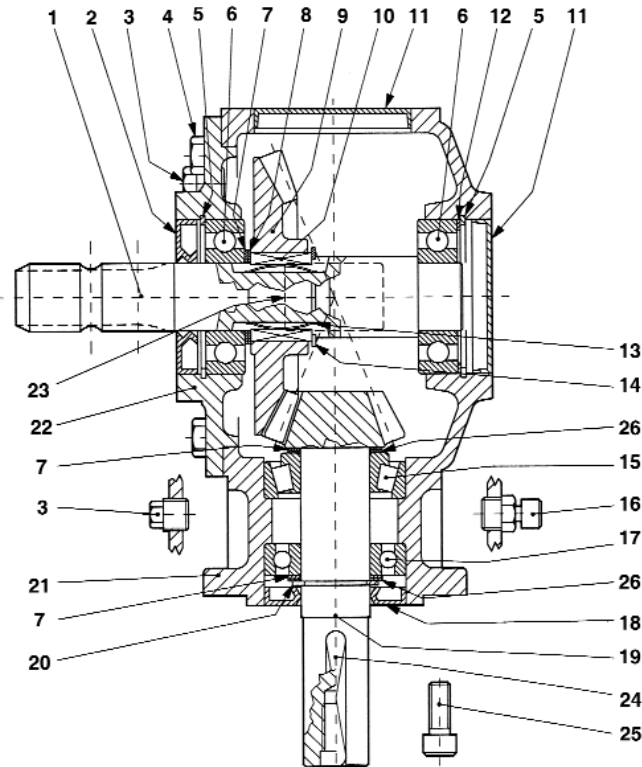

<u>REF#</u>	<u>QTY.</u>	<u>PART NO.</u>	<u>DESCRIPTION</u>
1	1	48030615	SPL. Shaft F.W. 1" 3/8 Z6 (0.311.3201.00)
2	1	48030811	Oil Seal 40 x 80 x 12 (8.7.1.00748)
3	1	48030246	Cap Ext. Hex. 3/8 NPT (8.6.5.00006)
4	1	96607627	Bolt TE M10 x 025 UNI 5739 8.8 Black
5	1	96874776	El. Ring F.Holes 80 x 2.5
6	1	75000029	Bearing 6307 A SFERE
7	1	48030281	Spacer 35.3 x 48 (0.259.7500.00)
8	1	48030984	Spacer 35.3 x 48 x 1 (0.259.7510.00)
9	1	48403053	Taper Crown WH.Z 28 M5.35 (0.311.6206.00)R
10	1	48030799	Feather For Free Wheel (0.267.7109.00)
11	1	48030267	Closing Cap 80 x 10 (8.7.0.00790)
12	1	48030884	Spacer 69.0 x 79.9 (0.267.7503.00)
13	1	48030983	Spring For Free Wheel (0.267.7110.00)
14	1	48030982	El. Ring F.Shafts 42 (8.5.1.00712)
15	1	48030411	Bearing 32207 A RULLI CON.
16	1	48030003	Cap 3/8" G (8.6.7.00161) NPT
17	1	36902003	Bearing 6207 35 x 72 x 17 Ball Bearing
18	1	48030180	Oil Seal 35 x 72 x 10
19	1	48403054	Albero Pinion Z11 M5.35 (0.304.5014.00)
20	1	96864576	El. Ring F. Shafts 35 x 2.5
21	1	48030991	Gearbox T2 (0.311.0300.00)
22	1	48030992	Open Cover Protection (0.311.1300.00) T2
24	1	48030753	Feather A 10 x 8 x 65 (8.4.1.01689)
25	1	96693823	Bolt TCEI M12 x 030 UNI 5931 8.8 Black
26	1	48030535	Spacer 48.0 x 35.3 x 1.3 (0.259.7513.00)

# GCF41-61 PTO SHAFT

Bondioli & Pavesi

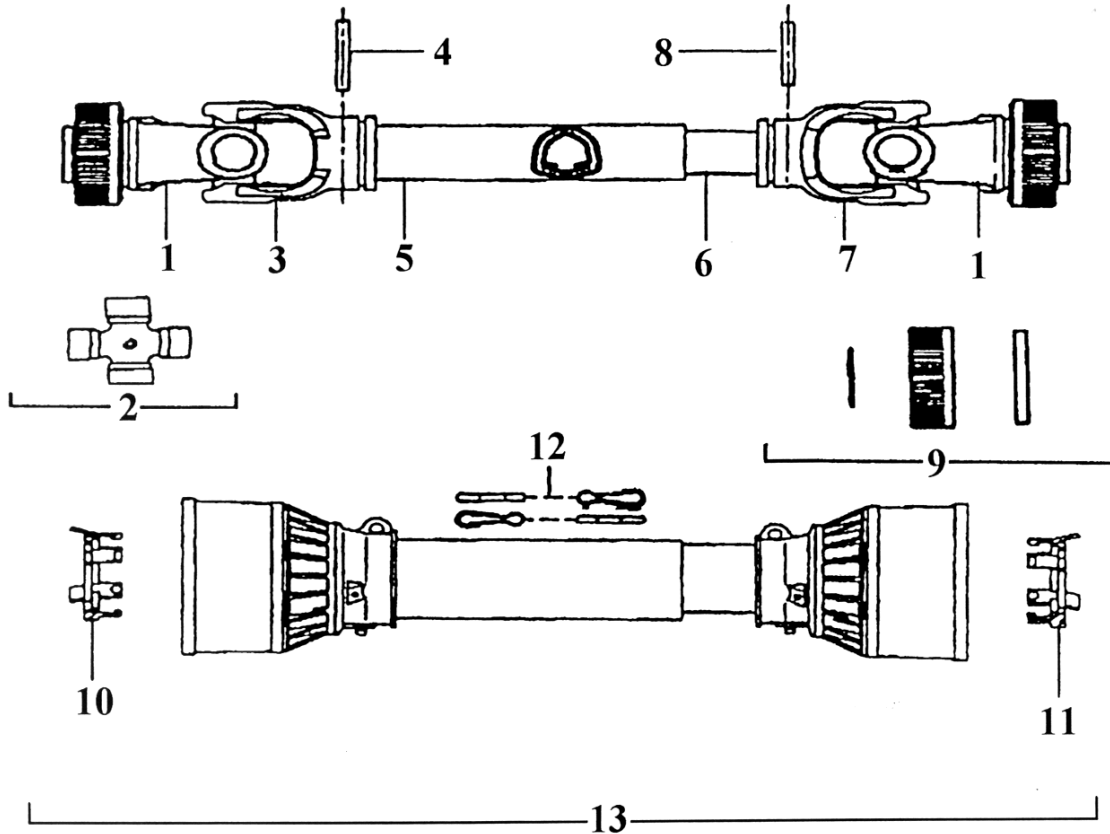

<u>REF#</u>	<u>QTY.</u>	<u>PART NO.</u>	<u>DESCRIPTION</u>
1	2	572040351	RS Yoke 1-3/8 6 Spline
2	2	41204	#4 Cross Kit
3	1	204046851	Outer Tube Yoke
4	1	341038000	Roll Pin O.T.
5	1	225120860	Outer Drive Tube 860 mm
6	1	225100860	Inner Drive Tube 860 mm
7	1	204046852	Inner Tube Yoke
8	1	341048000	Roll Pin I.T.
9	2	240002451	RS Collar Kit
10	1	255040005	Shield Bearing Outer
11	1	255040006	Shield Bearing Inner
12	2	252000001	Safety Chain
13	1	5F04086F6	Complete Shield w/Bearings
	1	7104071UCR07R07	Complete Driveline Assembly

*Please specify driveline manufacturer when ordering parts.*

# GCF69-79 PTO SHAFT

Bondioli & Pavesi

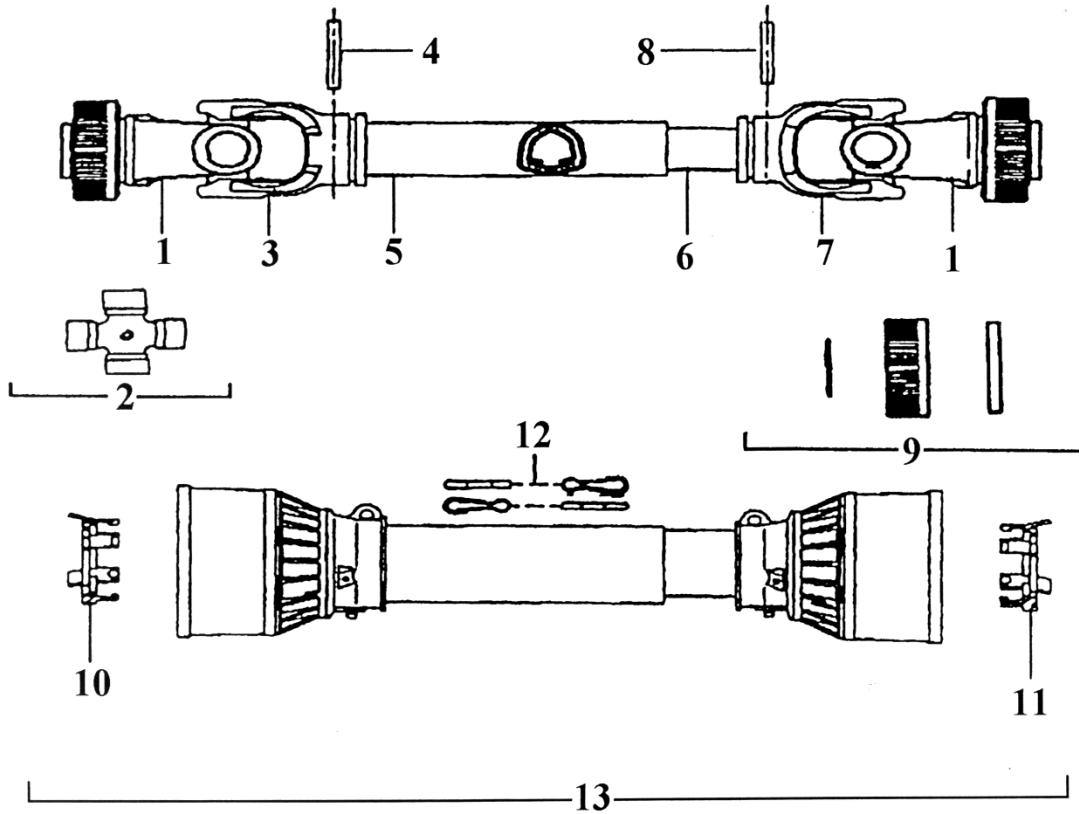

<u>REF#</u>	<u>QTY.</u>	<u>PART NO.</u>	<u>DESCRIPTION</u>
1	2	572060351	RS Yoke 1-3/8 6 Spline
2	2	41206	#6 Cross Kit
3	1	204066851	Outer Tube Yoke
4	1	341042000	Roll Pin O.T.
5	1	225690860	Outer Drive Tube 860 mm
6	1	225110860	Inner Drive Tube 860 mm
7	1	204066852	Inner Tube Yoke
8	1	341043000	Roll Pin I.T.
9	2	240003051	RS Collar Kit
10	1	255060005	Shield Bearing Outer
11	1	255060006	Shield Bearing Inner
12	2	252000001	Safety Chain
13	1	5F06086FF	Complete Shield w/Bearings
	1	7106086T07S07	Complete Driveline Assembly

*Please specify driveline manufacturer when ordering parts.*

# GCF41-61 PTO SHAFT

## Weasler

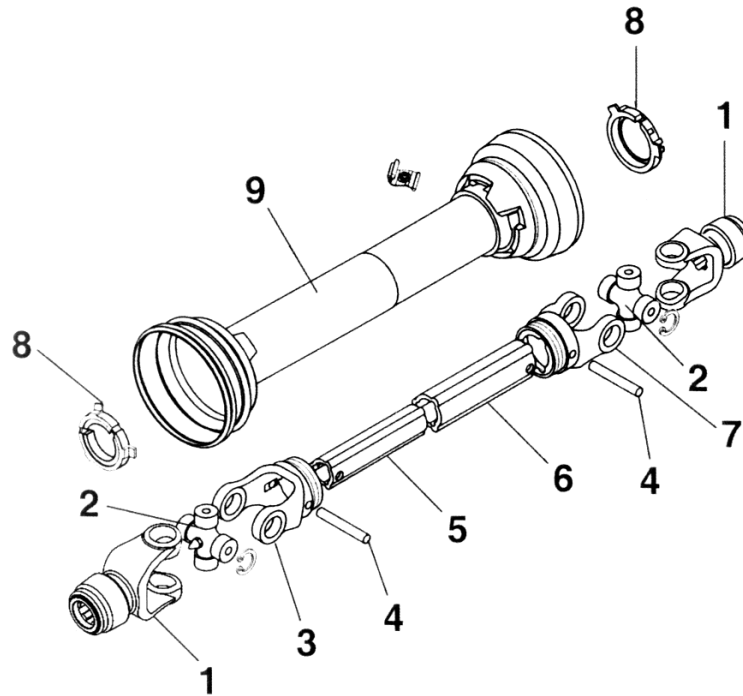

<u>REF#</u>	<u>QTY.</u>	<u>PART NO.</u>	<u>DESCRIPTION</u>
1	2	400.421638	Yoke Auto Lock
2	2	201-8474	Cross and Bearing Kit
3	1	410.400236	Yoke Inner Tube
4	2	795.0865	Spring Pin 8 x 65
5	1	710.364	Inner Tube
6	1	710.433	Outer Tube
7	1	410.400243	Yoke Outer Tube
8	2	961-2543	Bearing Kit
9	1	900-2560	Shield Kit
	1	13006500	Safety Chain Kit (Not Shown)
	1	ZB4071638	Complete Driveline Assembly

*Please specify driveline manufacturer when ordering parts.*



# GCF69-79 PTO SHAFT

## Weasler

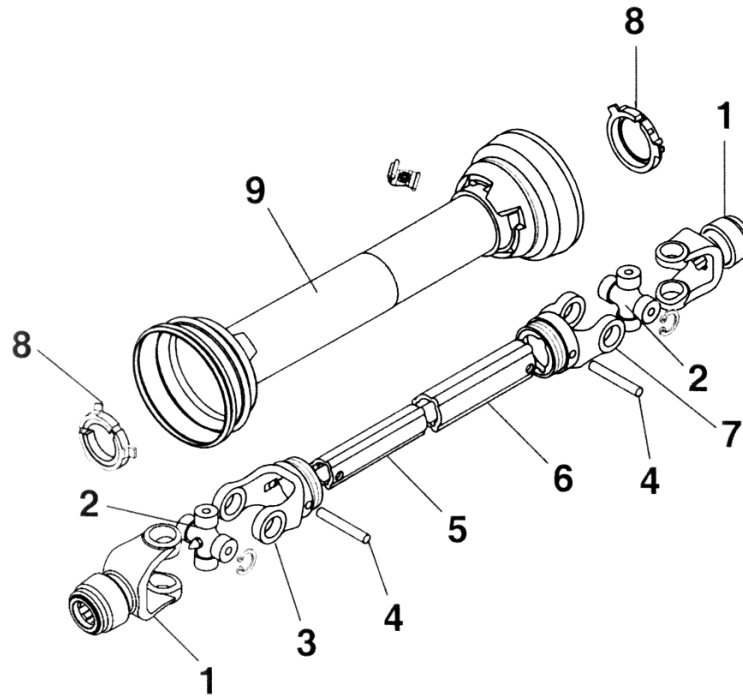

<u>REF#</u>	<u>QTY.</u>	<u>PART NO.</u>	<u>DESCRIPTION</u>
1	2	110-8606	Yoke Auto Lock
2	2	201-8692	Cross and Bearing Kit
3	1	410.600245	Yoke Inner Tube
4	2	795.1080	Spring Pin 10 x 80
5	1	710.454	Inner Tube
6	1	710.544	Outer Tube
7	1	410.600254	Yoke Outer Tube
8	2	961-3567	Bearing Kit
9	1	902-3560	Shield Kit
	1	13006500	Safety Chain Kit (Not Shown)
	1	AB608363	Complete Driveline Assembly

*Please specify driveline manufacturer when ordering parts.*

# LIMITED WARRANTY



GEARMORE, INC., warrants each new Gearmore product to be free from defects in material and workmanship for a period of twelve (12) months from date of purchase to the original purchaser. This warranty shall not apply to implements or parts that have been subject to misuse, negligence, accident, or that have been altered in any way.

Our obligation shall be limited to repairing or replacement of any part, provided that such part is returned within thirty (30) days from date of failure to Gearmore through the dealer from whom the purchase was made, transportation charges prepaid.

This warranty shall not be interpreted to render us liable for injury or damages of any kind or nature, direct, consequential or contingent, to person or property. This warranty does not extend to loss of crops, loss because of delay in harvesting or any other expenses, for any other reasons.

Gearmore in no way warranties engines, tires, or other trade accessories, since these items are warranted separately by these respective manufacturers.

Gearmore reserves the right to make improvements in design or changes in specification at any time, without incurring any obligations to owners or units previously sold.

GEARMORE, INC.  
13477 Benson Ave.  
Chino, CA 91710

Always refer to and heed machine operating warning decals on machine.

*The serial number of this product is stored in our computer database, thus submitting a warranty registration card is not required.*