



BOX SCRAPER

**Operation, Service
& Parts Manual For
GBS-R Retractable &
GBS-H Hydraulic
Series Scrapers**

December 2014 Rev.

TABLE OF CONTENTS

Training & Preparation	1
Operational Safety	2
Set-Up & Servicing	3
Retractable Scraper Parts Breakdown	4-5
Hydraulic Scraper Parts Breakdown	6-7
Limited Warranty	8

Date of Purchase: _____

Model Number: _____

Serial Number _____

INTRODUCTION

We welcome you as an owner of a Gearmore box scraper. Please read the following instructions and refer to them when required:

TRAINING

With normal maintenance you should receive years of use out of the box scraper.

1. Safety instructions are important! Read this manual, the tractor manual and all safety rules.
2. Know your controls and how to stop tractor engine quickly in an emergency.
3. Operators **must** be instructed in and be capable of the safe operation of the equipment, its attachments and all controls. **Do not** allow anyone to operate this equipment without proper instructions.
4. **Do not** allow children or unqualified persons to operate equipment

PREPARATION

1. **Always** wear relatively tight and belted clothing to avoid entanglement in moving parts. Wear sturdy, rough-soled work shoes and protective equipment for eyes, hands, hearing and head.
2. Ensure box scraper is properly mounted, adjusted and in good operating condition.
3. Ensure all safety decals are installed and in good condition.
4. A minimum 20% of tractor and equipment weight **must** be on tractor from wheels with box scraper in transport position. Without this weight, tractor could tip over causing personal injury or death. The weight may be attained with front wheel weights, ballast in tires or front tractor weights. When attaining the minimum 20% weight on the front wheels, you **must not** exceed the Roll Over Protection Structure (ROPS) weight certification. Weight tractor and equipment. **Do not** guess or estimate.

OPERATIONAL SAFETY

Know your controls and how to stop tractor engine and box scraper quickly in an emergency. ***READ THIS OPERATOR'S MANUAL AND THE MANUAL PROVIDED WITH YOUR TRACTOR.***

- Keep bystanders away from equipment while it is in operation.
- Operate only in daylight or good artificial light.
- Keep hands and feet away from box scraper while tractor engine is running. Stay clear of all moving parts.
- If your tractor is equipped with a ROPS, you ***must*** wear your seat belt.
- Always*** comply with all state and local lighting and marking requirements.
- No riders*** are allowed on tractor or box scraper.
- Start engine from operator's seat after placing transmission in neutral.
- Make sure area behind your tractor is clear before operating in reverse.
- Do not*** operate on steep slopes.
- Do not*** stop, start or change directions suddenly on slopes.
- Use ***extreme*** care and reduce ground speed on slopes and rough terrain.
- Watch for hidden hazards on the terrain during operation.
- Keep alert and watch ahead as well as behind the tractor when working with the box scraper.
- Ensure equipment is properly mounted to tractor before making adjustments.
- Always*** be sure the box scraper is in the fully raised position when in transport.
- When turning close to buildings or passing through narrow areas, be sure to allow sufficient clearance for the box scraper.
- Make adjustments using hydraulic controls only when seated in operator's position.
- Set parking brake, lower equipment close to ground, turn tractor engine off and remove key before making manual adjustments. Keep yourself behind and out from underneath equipment to make adjustments. Be aware gravity forces can rotate or lower equipment and trap or pinch you.
- Stop tractor immediately upon striking an obstruction. Turn off engine, remove key, inspect and repair any damage before resuming operation.
- Block box scraper securely before working underneath.
- Lower box scraper to ground, stop engine, set parking brake and remove key before dismounting tractor.

SERVICING INSTRUCTIONS

MAINTENANCE SAFETY

1. Lower box scraper to ground, turn tractor engine off and remove key before performing any service or maintenance.
2. Block box scraper securely before working underneath.
3. Keep all persons away from operator control area while performing adjustments, service or maintenance.
4. Periodically tighten all bolts, nuts and screws to ensure blade is in a safe condition.
5. Ensure all safety decals are installed and in good condition.

SET-UP INSTRUCTIONS

TOP HOLE: The top hole is designed for use in the retractable shank and hydraulic shank box scrapers only. *Do not* use any other hole in the shank except the top hole.

On the GBS-R Retractable Shank Box Scraper you manually raise and lower the shank bar by pulling the handle.

On the GBS-H Hydraulic Shank Box Scraper you activate the hydraulic control valve to raise and lower the shank bar.

SERVICING INSTRUCTIONS

CUTTING EDGE:

For reversing the cutting edge, remove 5/8" plow bolts. Remove the cutting edge from moldboard and reinstall with the sharp edge down. Replace it when both edges are worn.

BOLTS:

Keep all the bolts tight at all times by checking them periodically. Replace the bolts only with those having the same marks on the heads as on original bolt. Marks on bolt head indicate high strength.

GBS-R PARTS DRAWING

19 SIDE VIEW

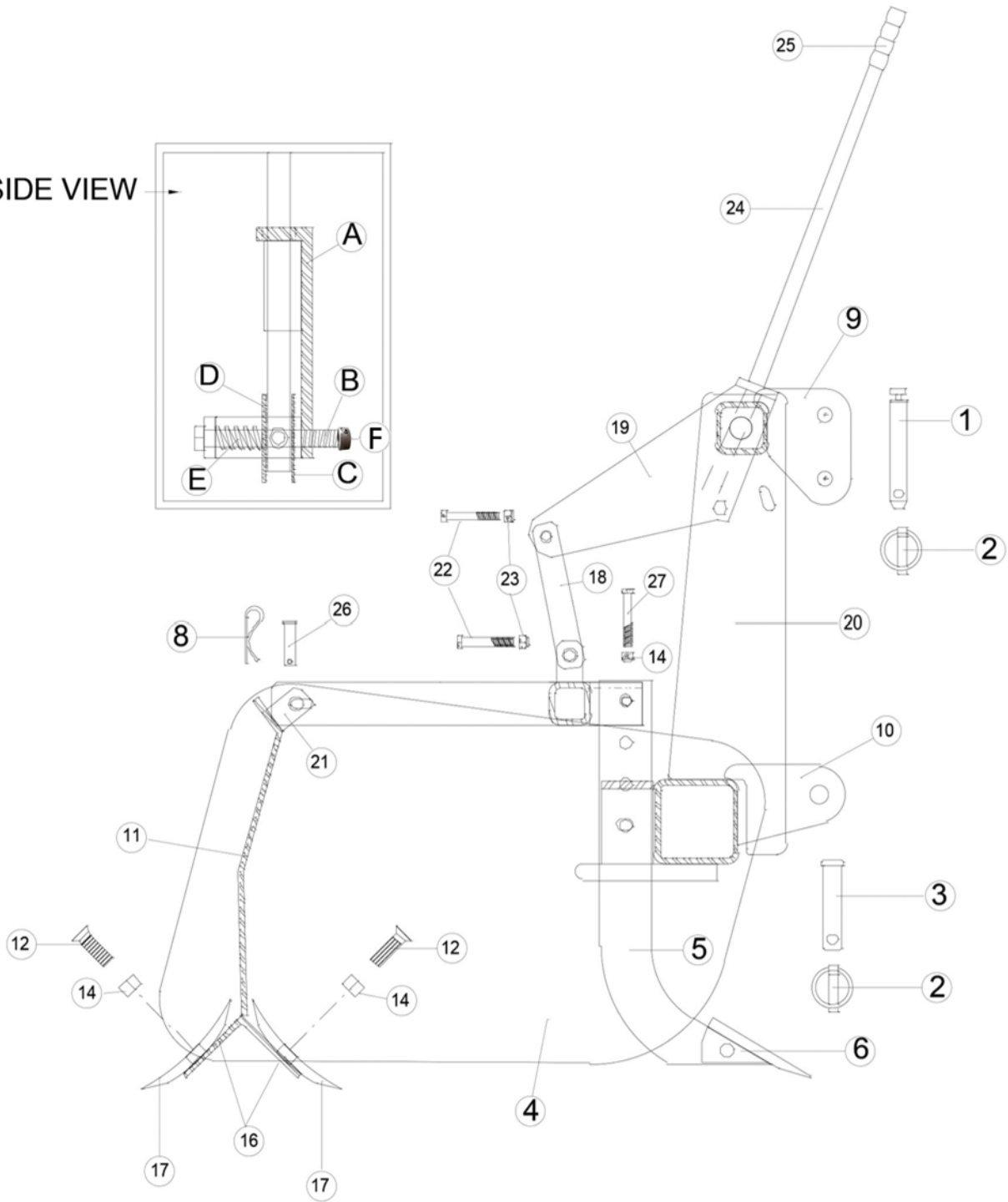

GBS-R PARTS LIST

<u>REF.</u>	<u>QTY.</u>	<u>PART NO.</u>	<u>DESCRIPTION</u>
1	1	P075500C1TL	Cat I Top Link Pin
2	3	P716175LY	7/16" x 1 3/4" Lynch Pin
3	2	P078375C1D	Cat. I Draw Pins
4	2	P01011	Side Plate 42" - 66"
4	2	P02011	Side Plate 72" - 84"
5	As Req'd	H434	Shank with Tip
6	As Req'd	RPS76931	Replaceable Tip
8	5	P11	Hair Pin
9	2	P030201	Cat. I Top Link Ear
10	4	P030191	Cat. I Draw Ear
11	1	XXXXXX	Back Plate
12	As Req'd	GR85/8X2	5/8" Plow Bolt
14	As Req'd	GR85/8NC	5/8" Hex Nut
17	2	CE42	42" Cutting Edge
17	2	CE48	48" Cutting Edge
17	2	CE54	54" Cutting Edge
17	2	CE60	60" Cutting Edge
17	2	CE66	66" Cutting Edge
17	2	CE72	72" Cutting Edge
17	2	CE76	76" Cutting Edge
17	2	CE80	80" Cutting Edge
17	2	CE84	84" Cutting Edge
18	2	F03004	Tall Mast Lift Arm Link
19	1	P02BSR01	"L" Bracket
19A	1	F1101	"L" Bracket
19B	1	B050600RT	1/2" x 6" Bolt
19C	1	P11	Hair Pin
19D	1	W050F	1/2" Flat Washer
19E	1	S050250COM	Compression Spring
19F	1	SC100050SS	Lock Collar w/Set Screw
20	2	P03217R	Tall Mast
21	4	F11002	Lift Arm Ear
22	2	B05175	1/2" x 1 3/4" Bolt
23	2	N050L	1/2" Nylock
24	1	X01001	Retractable Handle
25	1	14505S	Handle Grips
26	2	P050150CL	1/2" x 1 1/2" Clevis Pin
27	3	B038250S	3/8" x 2 1/2" Shank Bolt

As Required

Part Number	42"	48"	54"	60"	66"	72"	76"	80"	84"
H434	3	4	4	5	6	6	7	7	7
RPS76931	3	4	4	5	6	6	7	7	7
GR85/8X2	8	8	10	10	12	12	14	14	14
GR85/8NC	8	8	10	10	12	12	14	14	14

GBS-H PARTS DRAWING

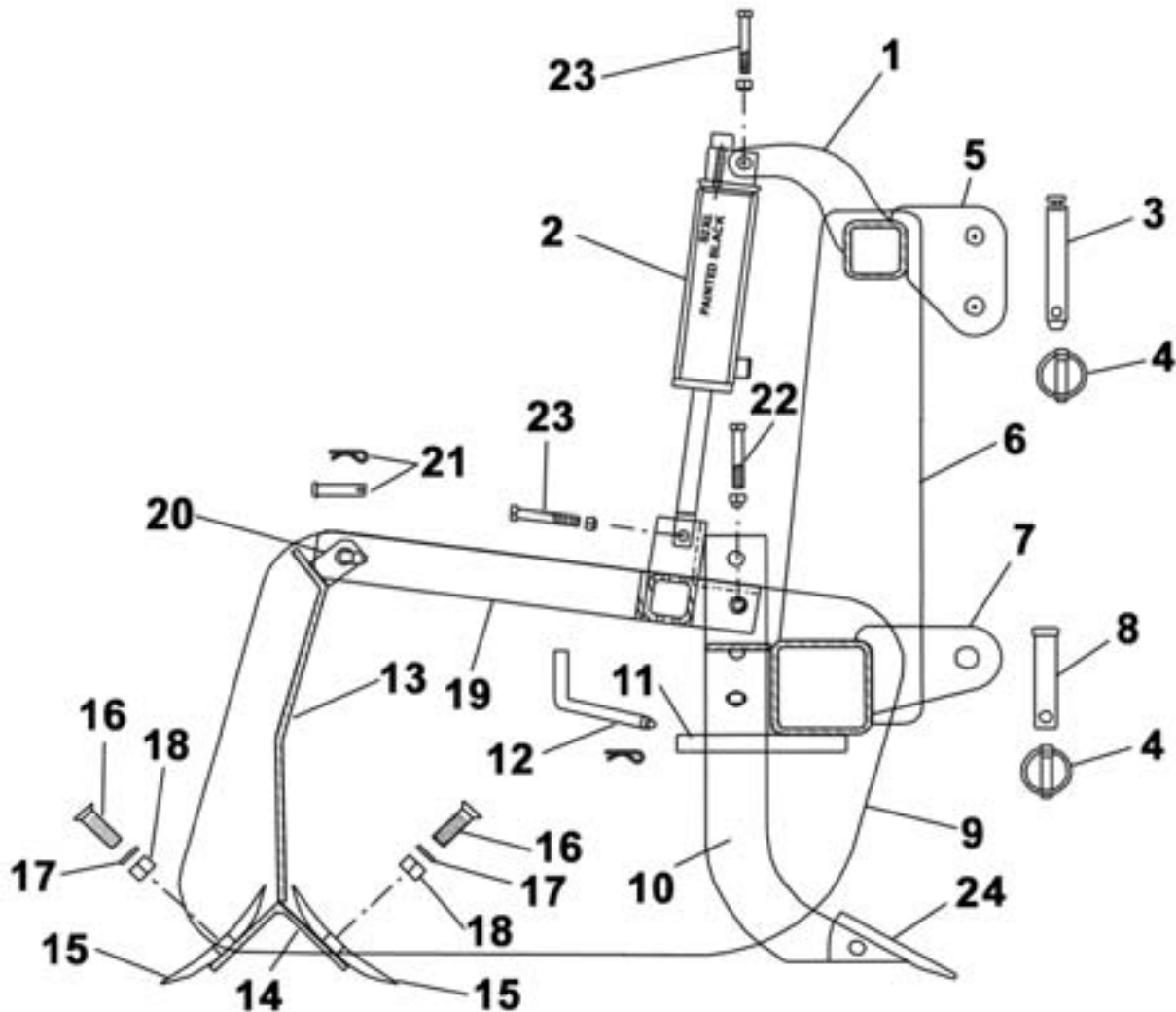

REF. #	QTY.	PART NO.	DESCRIPTION
1	2	P02006	Top Cylinder Ear
2	1	S2X6	2" x 6" Hydraulic Cylinder
3	1	P075500C1TL	Cat. 1 Top Link Pin
4	3	P716175LY	Lynch Pin
5	2	P03020	Top Link Ear
6	2	P03217	Mast
7	4	P03019	Draw Ear
8	2	P078375C1D	Lower Lift Pin
9	2	P01011	1/4" Side Plate f/42", 48", 54", 60", & 66"
9	2	P02011	3/8" Side Plate f/72", 76", 80", 84", & 96"
10	As Req'd*	H434	4 Hole Shank w/Tip

GBS-H PARTS DRAWING

<u>REF. #</u>	<u>QTY.</u>	<u>PART NO.</u>	<u>DESCRIPTION</u>
11	As Req'd*	A07014WA	Shank Pocket Assembly
12	As Req'd*	P050300BL	Shank Pin w/Clip
13	1	P01002	Back Plate 42"
13	1	P01012	Back Plate 48"
13	1	P01022	Back Plate 54"
13	1	P01031	Back Plate 60"
13	1	P01042	Back Plate 66"
13	1	P01054	Back Plate 72"
13	1	P01062	Back Plate 76"
13	1	P01072	Back Plate 80"
13	1	P01082	Back Plate 84"
13	1	P01092	Back Plate 96"
14	1	A05003	Cutting Edge Angle 42"
14	1	A05013	Cutting Edge Angle 48"
14	1	A05023	Cutting Edge Angle 54"
14	1	A05033	Cutting Edge Angle 60"
14	1	A05043	Cutting Edge Angle 66"
14	1	A05053	Cutting Edge Angle 72"
14	1	A05063	Cutting Edge Angle 76"
14	1	A05073	Cutting Edge Angle 80"
14	1	A05083	Cutting Edge Angle 84"
14	1	A05093	Cutting Edge Angle 96"
15	1	CE42	Cutting Edge 42"
15	1	CE48	Cutting Edge 48"
15	1	CE54	Cutting Edge 54"
15	1	CE60	Cutting Edge 60"
15	1	CE66	Cutting Edge 66"
15	1	CE72	Cutting Edge 72"
15	1	CE76	Cutting Edge 76"
15	1	CE80	Cutting Edge 80"
15	1	CE84	Cutting Edge 84"
15	1	CE96	Cutting Edge 96"
16	As Req'd*	GR85/8X2	5/8" x 2" Plow Bolt
17	As Req'd*	W058L	5/8" Flat Washer Grade 5
18	As Req'd*	GR85/8NC	5/8" Hex Nut Grade 5
19	1	T01011HA	Shank Bar Assy 42"
19	1	T010111HA	Shank Bar Assy 48"
19	1	T010211HA	Shank Bar Assy 54"
19	1	T010311HA	Shank Bar Assy 60"
19	1	T010411HA	Shank Bar Assy 66"

GBS-H PARTS DRAWING

<u>REF. #</u>	<u>QTY.</u>	<u>PART NO.</u>	<u>DESCRIPTION</u>
19	1	T010511HA	Shank Bar Assy 72"
19	1	T010611HA	Shank Bar Assy 76"
19	1	T010711HA	Shank Bar Assy 80"
19	1	T010811HA	Shank Bar Assy 84"
19	1	T010911HA	Shank Bar Assy 96"
20	4	F11002	Lift Arm Ear
21	2	P050150CL	1/2" x 1 1/2" Clevis Pin w/Hair Pin
22	As Req'd*	B038250S	Shank Bolt w/Nut
23	2	P100325	Cylinder Pin w/Nut
24	As Req'd*	RPS76931	Tooth, Shank

*QUANTITY CHART

MODEL NO.	NUMBER OF SHANKS W/TIP (H434)	NO. OF SHANK POCKET ASSY (A07014WA)	NO. OF SHANK PIN W/CLIP (P050300BL)	NO. OF 5/8" PLOW BOLT (B058200P)	NO. OF 5/8" FLAT WASHER (W058L)	NO. OF 5/8" HEX NUT (N058H)	SHANK BOLT W/NUT (B038250S)
GBS42H	3	3	3	8	8	8	3
GBS48H	4	4	4	8	8	8	4
GBS54H	4	4	4	10	10	10	4
GBS60H	5	5	5	10	10	10	5
GBS66H	5	5	5	12	12	12	5
GBS72H	6	6	6	12	12	12	6
GBS76H	6	6	6	14	14	14	6
GBS80H	6	6	6	14	14	14	6
GBS84H	7	7	7	14	14	14	7
GBS96H	8	8	8	16	16	16	8

LIMITED WARRANTY



GEARMORE, INC., warrants each new Gearmore product to be free from defects in material and workmanship for a period of twelve (12) months from date of purchase to the original purchaser. This warranty shall not apply to implements or parts that have been subject to misuse, negligence, accident, or that have been altered in any way.

Our obligation shall be limited to repairing or replacement of any part, provided that such part is returned within thirty (30) days from date of failure to Gearmore through the dealer from whom the purchase was made, transportation charges prepaid.

This warranty shall not be interpreted to render us liable for injury or damages of any kind or nature, direct, consequential or contingent, to person or property. This warranty does not extend to loss of crops, loss because of delay in harvesting or any other expenses, for any other reasons.

Gearmore in no way warrants engines, tires, or other trade accessories, since these items are warranted separately by these respective manufacturers.

Gearmore reserves the right to make improvements in design or changes in specification at any time, without incurring any obligations to owners or units previously sold.

GEARMORE, INC.
13477 Benson Ave.
Chino, CA 91710

Always refer to and heed machine operating warning decals on machine.

The serial number of this product is stored in our computer database, thus submitting a warranty registration card is not required.