

GEARMORE INC.

FLEX HITCH ROTARY MOWERS

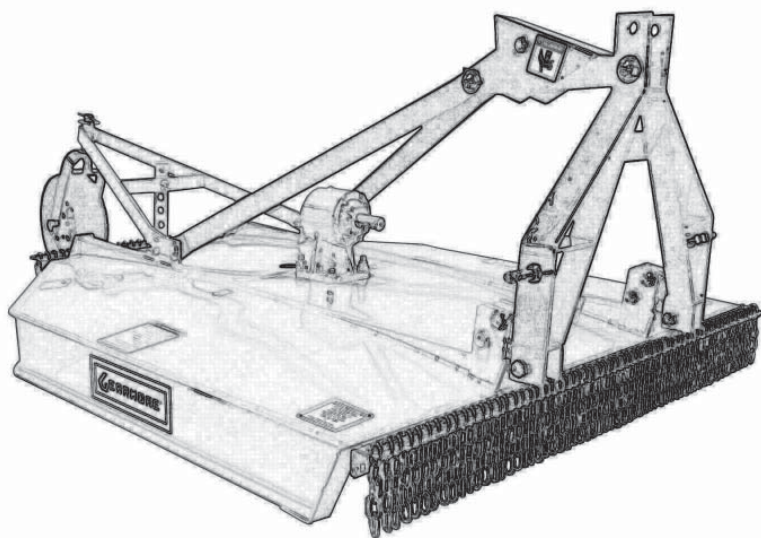

**Assembly, Operation, & Parts Manual
For Models: L-48-40-P-FH,
L-60-40-P-FL, L-60-40-SC-P-FH,
L-72-40-P-FH, & L-72-40-SC-P-FH**

January 2011

TABLE OF CONTENTS

<u>SECTION</u>	<u>DESCRIPTION</u>	<u>PAGE</u>
1	Introduction	1
1.1	Purchaser's Responsibility	1
2	Safety	2
2.1	General Safety	3
2.2	Equipment Safety Guidelines	4
2.3	Safety Training	5
2.4	Safety Signs	5
2.5	Preparation	6
2.5.1	Starting & Stopping	6
2.6	Operational Safety	7
2.7	Transport Safety	8
2.8	Storage Safety	8
2.9	Maintenance Safety	8
3	Safety Sign Decals	9 - 11
4	Assembly	12
4.1	Assembly Instructions	12
4.2	Before Putting Mower Into Service	13
4.3	Attaching To Tractor	14
4.4	Sizing PTO Shaft	15
5	Operating Instructions	16
5.1	Pre-Operational Adjustments	16
5.2	Cutting Height Adjustment	16
5.3	Rotary Mower Operation	17
6	Maintenance	18
6.1	Service Record	18
7	Replacement Parts	19
7.1	Parts Lists - Flex Hitch Rotary Mower	19
7.2	Parts Lists - Shear Pin PTO Shaft	20
7.3	Parts Lists - Slip Clutch PTO Shaft	21
7.4	Parts Lists - Slip Clutch Assembly	21
7.5	PTO Shafts Cover Removal	22 - 23
7.6	40 Horsepower Gearbox	24
8	Limited Warranty	25

1 INTRODUCTION

This manual contains valuable information about your new Gearmore Mower. It has been carefully prepared to give you helpful suggestions for operating, adjusting, servicing and ordering repair parts.

Keep this manual in a convenient place for quick and easy reference. Study it carefully. You have purchased a dependable and sturdy mower, but only by proper care and operation can you expect to receive the service and long life designed and built into it.

Sometime in the future your mower may need new parts to replace those that are worn or broken. If so, go to your dealer and provide him with the model and part number.

OPERATOR ORIENTATION - The directions left, right, front and rear, as mentioned throughout this manual, are as seen from the driver's seat and facing in the direction of travel.

1.1 PURCHASER'S RESPONSIBILITY

It is the responsibility of the purchaser and/or operator to.....

- Read and understand the information contained in this manual.
- Operate, lubricate, assemble and maintain the equipment in accordance with all instructions and safety procedures in this manual.
- Inspect the equipment and replace or repair any parts that are damaged or worn which under continued operation would cause damage, wear to other parts, or cause a safety hazard.
- Return the equipment or parts to the authorized dealer, from where it was purchased, for service or replacement of defective parts that are covered by warranty. (The factory may inspect equipment or parts before warranty claims are honored.)
- Payment of all costs incurred by the dealer for traveling to or transporting the equipment for warranty inspection and or claims.

NAME: _____

PURCHASED FROM: _____

DATE OF PURCHASE: _____

MODEL NUMBER: _____

SERIAL NUMBER: _____

2 SAFETY

SAFETY ALERT SYMBOL

This Safety Alert symbol means **ATTENTION! BECOME ALERT! YOUR SAFETY IS INVOLVED!**

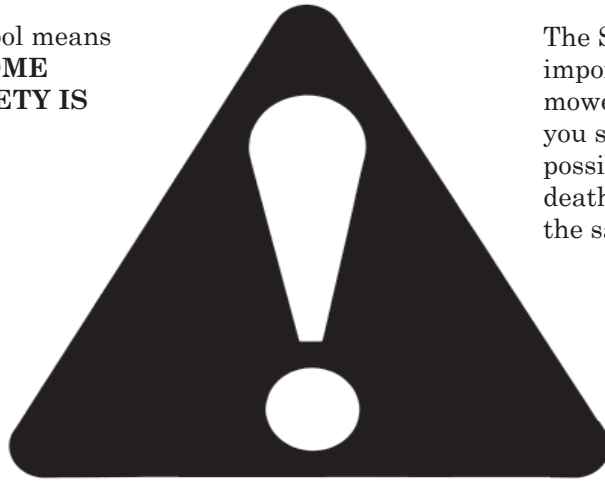

The Safety Alert symbol identifies important safety messages on the mower and in the manual. When you see this symbol, be alert to the possibility of personal injury or death. Follow the instructions in the safety message.

Why is SAFETY important to you?

3 Big Reasons

Accidents Disable and Kill
Accidents Cost
Accidents Can Be Avoided

SIGNAL WORDS:

Note the use of the signal words **DANGER**, **WARNING** and **CAUTION** with the safety messages. The appropriate signal word for each message has been selected using the following guide-lines:

SI NO LEE INGLES, PIDA AYUDA A AIGUIEN QUE SI LO LEA PARA QUE LE TRADUZCA LAS MIDIDAS DE SEGURIDAD.

DANGER - Indicates an imminently hazardous situation that, if not avoided, will result in death or serious injury. This signal word is to be limited to the most extreme situations typically for machine components which, for functional purposes, cannot be guarded.

WARNING - Indicates a potentially hazardous situation that, if not avoided, could result in death or serious injury, and includes hazards that are exposed when guards are removed. It may also be used to alert against unsafe practices.

CAUTION - Indicates a potentially hazardous situation that, if not avoided, may result in minor or moderate injury. It may also be used to alert against unsafe practices.

If you have any questions not answered in this manual or require additional copies or the manual is damaged, please contact your dealer.

2.1 GENERAL SAFETY

YOU are responsible for the **SAFE** operation and maintenance of your mower. **YOU** must ensure that you and anyone else who is going to operate, maintain or work around the mower be familiar with the operating and maintenance procedures and related **SAFETY** information contained in this manual. This manual will take you step-by-step through your working day and alerts you to all good safety practices that should be adhered to while operating the mower.

Remember, **YOU** are the key to safety. Good safety practices not only protect you, but also the people around you. Make these practices a working part of your safety program. Be certain that **EVERYONE** operating this equipment is familiar with the recommended operating and maintenance procedures and follows all the safety precautions. Most accidents can be prevented. Do not risk injury or death by ignoring good safety practices.

- Mower owners must give operating instructions to operators or employees before allowing them to operate the machine, and at least annually there after per OSHA (Occupational Safety and Health Administration) regulation 1928.57.
- The most important safety feature on this equipment is a **SAFE** operator. It is the operator's responsibility to read and understand **ALL** Safety and Operating instructions in the manual and to follow these. Most accidents can be avoided.
- A person who has not read and understood all operating and safety instructions is not qualified to operate the machine. An untrained operator exposes himself and bystanders to possible serious injury or death.
- **DO NOT** modify the equipment in any way. Unauthorized modification may impair the function and/or safety and could affect the life of the equipment.
- **Think SAFETY! Work SAFELY!**

1. Read and understand the Operator's Manual and all safety signs before operating, maintaining, or adjusting the mower.



2. Have a first-aid kit available for use should the need arise and know how to use it.



3. Have a fire extinguisher available for use should the need arise and know how to use it.



4. Wear appropriate protective gear. This list includes but is not limited to:

- A hard hat
- Protective shoes with slip resistant soles
- Protective goggles, glasses or face shield
- Heavy gloves
- Protective clothing

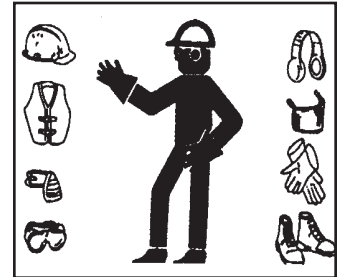

5. Install and secure all guards before starting.

6. **DO NOT** allow riders.

7. Wear suitable ear protection for prolonged exposure to excessive noise.



8. Place all controls in neutral, stop tractor engine, set park brake, remove ignition key and wait for all moving parts to stop before servicing, adjusting, repairing, or unplugging.

9. Clear the area of people, especially small children, before starting.

10. Review safety related items annually with all personnel who will be operating or maintaining the mower.

2.2 EQUIPMENT SAFETY GUIDELINES

Safety of the operator and bystanders is one of the main concerns in designing and developing a mower. However, every year many accidents occur which could have been avoided by a few seconds of thought and a more careful approach to handling equipment. You, the operator, can avoid many accidents by observing the following precautions in this section. To avoid personal injury or death, study the following precautions and insist those working with you, or for you, follow them.

- In order to provide a better view, certain photographs or illustrations in this manual may show an assembly with a safety shield removed. However, equipment should **never** be operated in this condition. Keep all shields in place. If shield removal becomes necessary for repairs, replace the shield prior to use.
- Replace any safety sign or instruction sign that is not readable or is missing. Location of such safety signs is indicated in this manual.
- **NEVER** use alcoholic beverages or drugs which can hinder alertness or coordination while operating this equipment. Consult your doctor about operating this machine while taking prescription medications.
- **Under no circumstances should young children be allowed to work with this equipment. Do not allow persons to operate or assemble this unit until they have read this manual and have developed a thorough understanding of the safety precautions and of how it works. Review the safety instructions with all users annually.**

- This equipment is dangerous to children and persons unfamiliar with its operation. The operator should be a responsible, properly trained and physically able person familiar with farm machinery and trained in this equipment's operations. If the elderly are assisting with farm work, their physical limitations need to be recognized and accommodated.
- Use a tractor equipped with a Roll Over Protective Structure (ROPS) and a seat belt.
- **NEVER** exceed the limits of a piece of machinery. If its ability to do a job, or to do so safely, is in question - **DON'T TRY IT.**
- Do not modify the equipment in any way. Unauthorized modification may impair the function and/or safety and could affect the life of the equipment.

In addition to the design and configuration of this implement, including Safety Signs and Safety Equipment, hazard control and accident prevention are dependent upon the awareness, concern, prudence and proper training of personnel involved in the operation, transport, maintenance and storage of the machine. Refer also to Safety Messages and operation instruction in each of the appropriate sections of the tractor and machine manuals. Pay close attention to the Safety Signs affixed to the tractor and the rotary mower.

Think SAFETY! Work SAFELY!

! WARNING



Before operating your machine, stop and read this owners manual. Do not attempt to operate the unit until you fully understand the material covered in this manual. Without the knowledge contained in this manual, injury or death can result.

2.3 SAFETY TRAINING

Safety is a primary concern in the design and manufacture of our products. Unfortunately, our efforts to provide safe equipment can be wiped out by a single careless act of an operator or bystander.

In addition to the design and configuration of equipment, hazard control and accident prevention are dependent upon the awareness, concern, prudence and proper training of personnel involved in the operation, transport, maintenance and storage of this equipment.

It has been said, "***The best safety feature is an informed, careful operator.***" We ask you to be that kind of an operator. It is the operator's responsibility to read and understand ALL Safety and Operating instructions in the manual and to follow these. Accidents can be avoided.



Working with unfamiliar equipment can lead to careless injuries. Read this manual, and the manual for your tractor, before assembly or operating, to acquaint yourself with the machines. If this machine is used by any person other than yourself, or is loaned or rented, it is the machine owner's responsibility to make certain that the operator, prior to operating:

- a. Reads and understands the operator's manuals.
- b. Is instructed in safe and proper use.

Should ownership of the equipment be transferred, this manual must also be transferred.

Know your controls and how to stop tractor, engine and machine quickly in an emergency. Read this manual and the one provided with your tractor.

Train all new personnel and review instructions frequently with existing workers. Be certain only a properly trained and physically able person will operate the machinery. A person who has not read and understood all operating and safety instructions is not qualified to operate the machine. An untrained operator exposes himself and bystanders to possible serious injury or death. If the elderly are assisting with farm work, their physical limitations need to be recognized and accommodated.

For any part of this manual that you do not understand, contact your dealer or Gearmore, Inc.

2.4 SAFETY SIGNS

1. Safety decals and this manual must be considered a permanent part of your equipment.
2. Keep safety signs clean and legible at all times.
3. Replace safety signs that are missing or have become illegible.
4. Replaced parts that displayed a safety sign should also display the current sign.
5. Safety signs are available from your authorized dealer or from Gearmore.

How To Install Safety Signs:

- Be sure that the installation area is clean and dry.
- Be sure temperature is above 50° F (10° C).
- Determine exact position before you remove the backing paper. (*See Section*)
- Remove the smallest portion of the split backing paper.
- Align the sign over the specified area and carefully press the small portion with the exposed sticky backing in place.
- Slowly peel back the remaining paper and carefully smooth the remaining portion of the sign in place.
- Small air pockets can be pierced with a pin and smoothed out using the piece of sign backing paper.

2.5 PREPARATION

1. Never operate the tractor and machine until you have read and completely understand this manual, the Tractor Operator's Manual and each of the Safety Messages found on the safety signs on the tractor and mower.

2. Personal protection equipment, including hard hat, safety glasses, safety shoes and gloves are recommended during assembly, installation, operation, adjustment, maintaining, repairing, removal or moving the implement. **DO NOT** allow long hair, loose fitting clothing or jewelry to be around equipment.

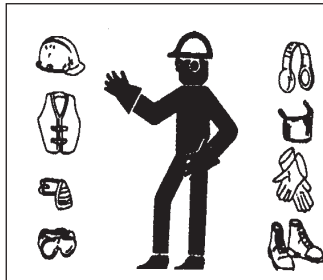

3. **PROLONGED EXPOSURE TO LOUD NOISE MAY CAUSE PERMANENT HEARING LOSS!**

Tractors with or without equipment attached can often be noisy enough to cause permanent, partial hearing loss. We recommend that you wear hearing protection on a full-time basis if the noise in the Operator's position exceeds 80db. Noise over 85db on a long-term basis can cause severe hearing loss. Noise over 90db adjacent to the Operator over a long-term basis may cause permanent, total hearing loss.

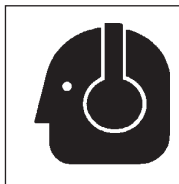

NOTE: Hearing loss from loud noise (from tractors, chain saws, radios, and other such sources close to the ear) is cumulative over a lifetime without hope of natural recovery.

4. Operate the mower only with a tractor equipped with an approved Roll-Over Protective Structure (ROPS). Always wear your seat belt. Serious injury or even death could result from falling off the tractor --- particularly during a turn-over when the operator could be pinned under the ROPS or the tractor.



5. Clear working area of stones, branches or hidden obstacles that might be hooked or snagged, causing injury or damage.
6. Operate only in daylight or good artificial light.
7. Ensure mower is properly mounted, adjusted and in good operating condition.
8. Ensure that all safety shielding and safety signs are properly installed and in good condition.

2.5.1 STARTING & STOPPING

- ▶ Check the tractor master shield over the PTO stub shaft. Make sure it is in good condition and fastened securely to the tractor. Purchase a new shield if old shield is damaged or missing.
- ▶ All tractors that are not equipped with a "live" power takeoff (PTO) need to be equipped with an over-running PTO clutch. These are available through most farm equipment stores. **NOTE:** The addition of an over-running PTO clutch may change the length of the PTO driveline required. Pay extra attention to the instructions on the PTO driveline installation. Be sure that the driveline system guarding is adequate.
- ▶ Mower operating power is supplied from tractor PTO. Refer to your tractor manual for PTO engagement and disengagement instructions. Know how to stop tractor and mower quickly in case of an emergency.
- ▶ When engaging PTO, the engine RPM should always be at idle speed. Once engaged and ready to start cutting, raise PTO speed to 540 RPM and maintain throughout cutting operation.

2.6 OPERATIONAL SAFETY

The use of this equipment is subject to certain hazards that cannot be protected against by the mechanical means or product design. All operators of this equipment must read and understand this entire manual, paying particular attention to safety and operating instructions, prior to using. If there is something in this manual you do not understand, ask your supervisor, or your dealer, to explain it to you.

Most accidents occur because of neglect or carelessness. Keep all helpers and bystanders at least several hundred feet from an operating rotary mower. Only properly trained people should operate this machine. When machine is operated in populated areas where thrown objects could injure persons or property, ***operation must be stopped when anyone comes within several hundred feet.***

The majority of the accidents involve entanglement on the driveline, injury of bystanders by the objects thrown by the rotating blades, and operators being knocked off the tractor by low hanging limbs and then being run over by the mower. Accidents are most likely to occur with machines that are loaned or rented to someone who has not read the owner's manual and is not familiar with a rotary mower. The rotary mower is designed for use only on tractors with 540 RPM power take off.

Install and secure all guards and shields before starting or operating. The discharge chute, bands, flaps, driveline guards and shields should be used and maintained in good working condition. They should be inspected carefully, at least daily, for missing or broken cable, chain links, shields, or guards. (Worn items must be replaced at once to reduce possibility of injury) Disengage power takeoff (PTO) and place transmission in neutral before attempting to start engine.

Many varied objects, such as wire, cable, rope, or chains, can become entangled in the operating parts of the mower. These items could then swing outside the housing at greater velocities than the blades. Such a situation is extremely hazardous. Inspect the cutting area for such objects before mowing. Remove any like objects from the site. Never allow the cutting blade to contact such items. Cut material higher at first, allowing rotary mower to clear hidden objects. Never assume an area is clear. **ALWAYS CHECK!** Always stop the tractor, disengage PTO, set brake, shut off the tractor engine, remove the ignition key, lower implement to the ground and allow mower blades to come to a complete stop before dismounting tractor. Never leave equipment unattended with the tractor running.

Never place hands or feet under mower with tractor engine running or before you are sure all motion has stopped. Stay clear of all moving parts. Do not reach or place any part of your body under equipment until it is blocked securely.

Do not allow riders on the rotary mower or tractor at any time. There is no safe place for any riders. Do not operate unless all personnel, livestock, and pets are several hundred feet away to prevent injury by thrown objects. Never operate tractor and rotary mower under trees with low hanging limbs. Operators can be knocked off the tractor and then run over by the rotating blades.

The rotating parts of this machine have been designed and tested for rugged use. However, they could fail upon impact with heavy, solid objects such as steel guardrails and concrete abutment. Such impact could cause the broken objects to be thrown outward at very high velocities. To reduce the possibility of property damage, serious injury, or even death, never allow the cutting blades to contact such obstacles. Stop mower and tractor immediately upon striking an obstruction. Turn engine off, remove key, inspect and repair any damage before resuming operation. Stay alert for uneven terrain, holes, rocks, and roots and other hidden hazards. Keep away from drop-offs and hazards that could cause roll over.

Use extreme care and maintain minimum ground speed when transporting or operating on hillsides. Over rough ground and when operating close to ditches or fences. Be careful and slow down when turning sharp corners and changing direction on slopes. Do not start or stop suddenly on slopes. Avoid operation on steep slopes. In extremely uneven terrain, rear wheels weights, front tractor weight, and/or tire ballast should be used to improve stability. Pass rotary mower diagonally through sharp dips and avoid sharp drops to prevent "hanging up" tractor and rotary mower. Practice will improve your skills in maneuvering on rough terrain. Always cut down slopes, never across the face. Always check tractor manual for proper use on slopes.

When using a unit, a minimum 20% of tractor and equipment weight must be on tractor front wheels. Without this weight, tractor could tip over, causing personal injury or death. The weight may be attained with a front-end loader, front wheel weights, ballast in the tires or front tractor weights. When attaining a minimum 20% of tractor and equipment weight on the front wheels, you must not exceed the ROPS weight certification. Weigh the tractor and equipment. **Do not guess or estimate!**

2.7 TRANSPORT SAFETY

1. Comply with state and local laws governing highway safety and movement of farm machinery on public roads.
2. The use of flashing amber lights is acceptable in most localities. However, some localities prohibit their use. Local laws should be checked for all highway lighting and marking requirements.
3. At all times, when driving the tractor and equipment on the road or highway under 20 mph (32 kph) use flashing amber warning lights and a slow moving vehicle (SMV) identification emblem. Do not exceed 20 mph (32 kph). Reduce speed on rough roads and surfaces.
4. Plan your route to avoid heavy traffic.
5. Always install transport locks, pins, or brackets before transporting.
6. Do not drink and drive.
7. Be a safe and courteous driver. Always yield to oncoming traffic in all situations, including narrow bridges, intersections, etc. Watch for traffic when operating near or crossing roadways.
8. Turn into curves or go up or down hills only at a low speed and at a gradual steering angle. Make certain that at least 20% of the tractor's weight is on the front wheels to maintain safe steering. Slow down on rough or uneven surfaces.
9. Use extreme care and maintain minimum ground when operating close to ditches or fences. Be careful when turning sharp corners.
10. Never allow riders on either tractor or mower.

2.8 STORAGE SAFETY

1. Following operation, or when unhooking the mower, stop the tractor, set the brakes, disengage the PTO, shut off the engine and remove the ignition keys.
2. Store the unit in an area away from human activity.
3. Do not park equipment where it can be exposed to direct contact to livestock for long periods of time. Damage and livestock injury could result.
4. Make sure all parked machines are on a hard, level surface and engage all safety devices.

2.9 MAINTENANCE SAFETY

1. Good maintenance is your responsibility. Poor maintenance is an invitation to trouble.
2. Follow good shop practices.
 - Keep service area clean and dry.
 - Be sure electrical outlets and tools are properly grounded.
 - Use adequate light for the job at hand.

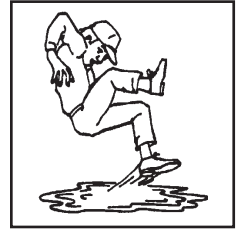

3. Make sure there is plenty of ventilation. Never operate the engine in a closed building. The exhaust fumes may cause asphyxiation.
4. Before working on this machine, disengage PTO, shut off the engine, set the brakes, and remove the ignition key. Be certain all moving parts on attachments have come to a complete stop before attempting to perform maintenance.
5. Never work under equipment unless it is blocked securely. Do not allow debris, grease or oil to build up on any deck or platform.
6. Use personal protection devices such as eye, hand, and hearing protectors, when performing any service or maintenance work.
7. Where replacement parts are necessary for periodic maintenance and servicing, genuine factory replacement parts **must** be used to restore your equipment to original specifications. The manufacturer will not be responsible for injuries or damages caused by use of unapproved parts and/or accessories.
8. A fire extinguisher and first aid kit should be kept readily accessible while performing maintenance on this equipment

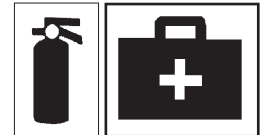

9. Check mower blades often. They should be sharp, free of nicks and cracks and securely fastened. Periodically tighten all bolts, nuts and screws and check that all cotter pins are properly installed to ensure unit is in a safe condition.
10. When completing a maintenance or service function, be sure all tools, parts, and service equipment are removed from mower, and make sure all safety shields and devices are installed before placing unit in service.

3 SAFETY DECALS & LOCATION

The types of safety signs and locations on the equipment are shown in the illustration below. Good safety requires that you familiarize yourself with the various safety signs, the type of warning and the area, or particular function related to that area, that requires your SAFETY AWARENESS. Should any decal become damaged or lost, it is the responsibility of the owner to replace it. Additional decals may be obtained from the manufacturer or Gearmore, Inc.

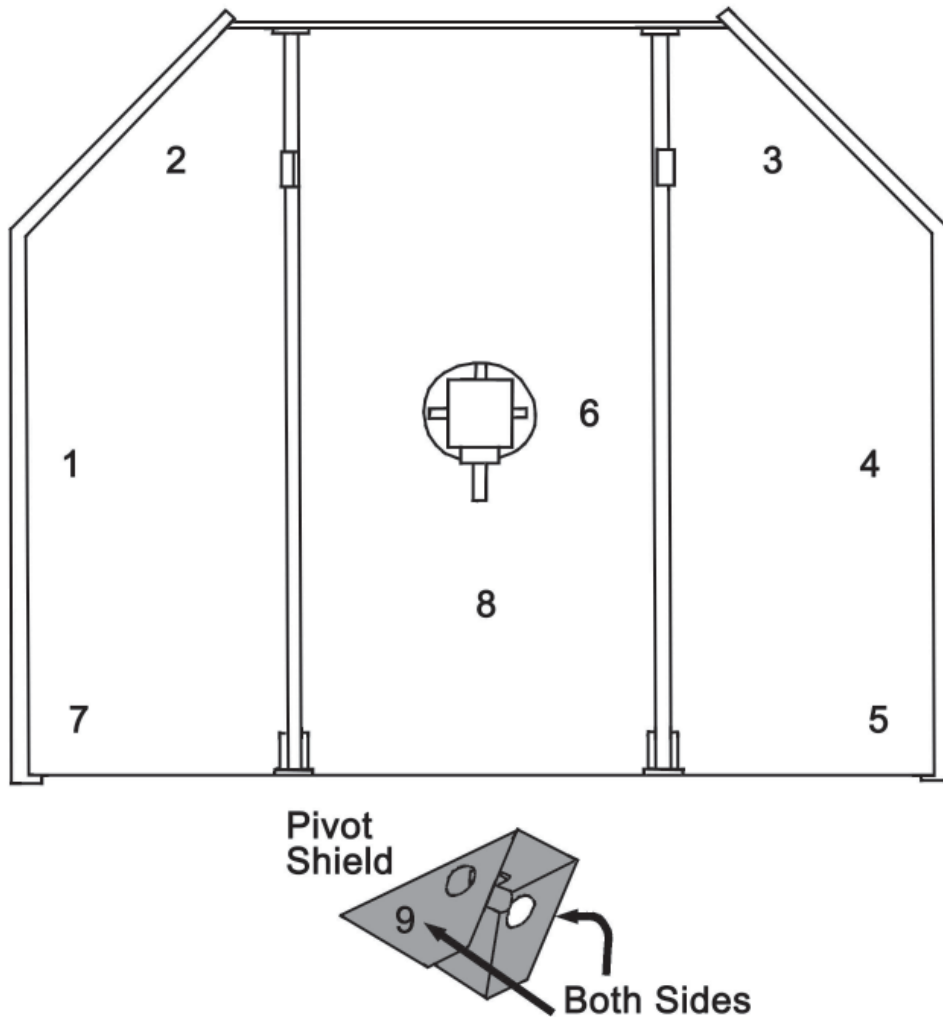

REMEMBER - If safety signs have been damaged, removed, become illegible or parts replaced without signs, new signs must be applied. New signs are available from your authorized dealer.



WARNING

To prevent serious injury or death:

Si no lee ingles, pida ayuda a alguien que si lo lea para que le traduzca las medidas de seguridad

- Read and understand the Operator's Manual before using. Review annually.
- Do not permit riders on the tractor or mower, including children.
- Do not allow children to operate mower.
- Operate only with guards installed and in good working condition.
- Keep away from moving parts.
- Operate only with tractor equipped with ROPS and seatbelts.
- Before mowing, clear debris from mowing area.
- Do not operate in the raised position.
- Stop engine, lower mower, set brake and wait for all moving parts to stop before dismounting.
- Support mower securely before working beneath unit.
- Transport with clean reflectors, SMV and working lights as required by federal, state, and local laws.
- Keep yourself, others, and clothing away from the rotating PTO.
- Keep others away from area to be mowed to avoid injury from flying objects.
- Do not stand between tractor and mower.
- Be careful on uneven terrain. Decrease speed when turning.
- Do not exceed a safe transport speed.

No. 1



DANGER

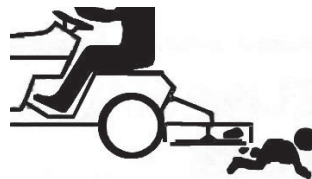

ROTATING BLADES - KEEP AWAY

To prevent serious injury or death when the engine is running and the blades are rotating:

- Never allow riders, especially children, on tractor or mower
- Do not operate with bystanders in mowing area.
- Do not operate with deflectors/guards removed.
- Do not place hands or feet under deck.
- Do not stand on or near implement at any time.
- Do not stand between tractor and implements.
- Operate only with tractor equipped with ROPS and seatbelts.

! DANGER



THROWN OBJECT HAZARD

To prevent serious injury or death:

- Do not operate unless all guards are installed and in good condition.
- Stop blade rotation if bystanders come within several hundred feet.

No. 3

! DANGER



**ROTATING DRIVELINE HAZARD
KEEP AWAY**

To prevent serious injury or death from rotating driveline:

- Keep all guards in place when operating.
- Operate only at 540 RPM.
- Keep hands, feet, clothing, and hair away from moving parts.
- Do not operate without driveline securely attached at both ends..
- Do not operate without driveline shields that turn freely on driveline.

No. 4

! WARNING



TO PREVENT SERIOUS INJURY OR DEATH

- Keep hands and body out of hitch area when attaching mower to tractor.
- Keep body clear of crush point between tractor and mower.

No. 5

**NO GREASE
IN FITTINGS
WHEN SHIPPED.**

No. 6

**Operators Manuals are
Available from
Your dealer, or**

**King Kutter, Inc.
P.O. Box 1200
Winfield, AL 35594
(205) 487-3202
www.kingkutter.com**

No. 7

! WARNING



No. 9



0399600518

**MODEL NO.
DESCRIPTION
SN# XXXXXXXXXXXX**

No. 8

4 ASSEMBLY

4.1 ASSEMBLY INSTRUCTIONS

Please follow the steps listed below to assemble your mower.

1. Place rotary mower on a flat level surface. (See *Figure A*)

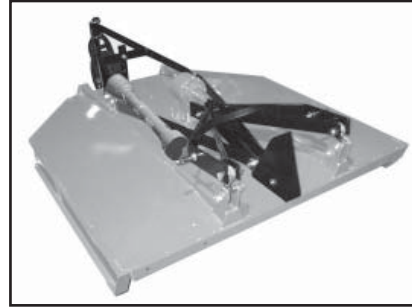

Figure A

2. Remove the wired on PTO shaft. Remove the (2) bolts that are on the lift arm lugs, and the bolt holding the pivot shield on. (See arrows *Figure C*) Place the (3) bolts, the pivot shield and the PTO shaft to the side, (See *Figure B*) you will replace these items as you put the unit together for service.



Figure B

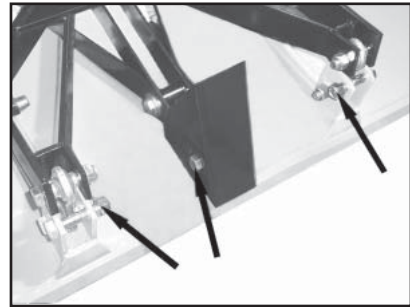

Figure C

3. Rotate arms up to a standing position (See *Figure D*) and replace the (2) two bolts once you get arms to full forward position with the swivel links below the bolts (See *Figure E*).

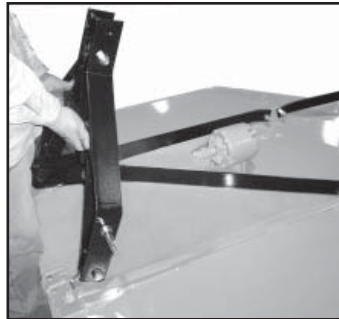

Figure D



Figure E

4. Then raise brace arms up and through where they bolt to pivot bar (See *Figure F & G*).

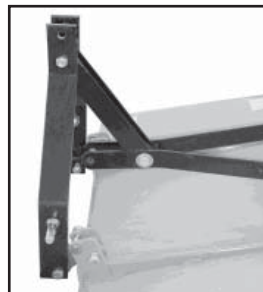

Figure F

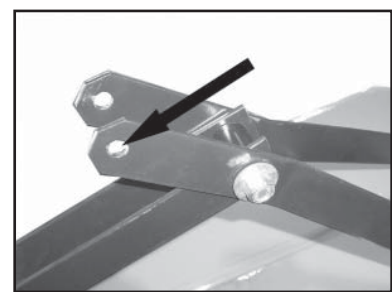

Figure G

5. Install the pivot shield with bolt, through shield and through lift arms and out other side of shield. (See hole *Figure G*). NOTE: Be sure long side of shield is towards tractor. Once you get the bolt in place it should look like (*Figure H*).

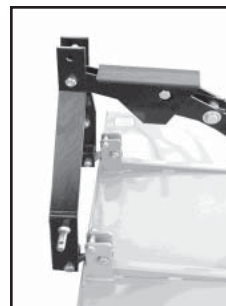

Figure H

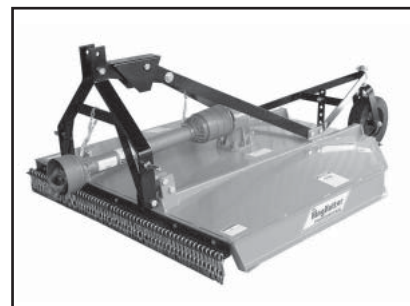

Figure I

6. Be sure and tighten all nuts and bolts. (*Figure I is complete unit assembled*)

4.2 BEFORE PUTTING ROTARY MOWER INTO SERVICE



**IMPORTANT - INSTRUCTIONS PRIOR TO START UP
SHIPPED WITH OIL IN GEARBOX
SHIPPED WITHOUT GREASE IN GREASE FITTINGS.
UNIT MUST BE SERVICED BEFORE USING.**

- Use Multi-Purpose Gear Oil (i.e. S.A.E. 80w/90 or S.A.E. 85w/140 Multi-purpose gear oil) in gearbox.
 - For all grease fittings use TYPE/grade II tube grease.
1. Place rotary mower so that the deck is secure and level.
 2. Remove 1/2" Pipe Plug (located at top of gearbox) and 1/8" Pipe Plug (located at lower 1/3 of gearbox) if oil comes out lower hole replace lower plug immediately and continue to Step 4. If no oil comes out continue to Step 3.
 3. Fill gearbox using multi-purpose gear oil through top 1/2" fill hole until gear oil is level with lower 1/8" hole.
 4. Replace both the 1/2" pipe plug (located at top of gearbox) and 1/8" pipe plug (located at lower 1/3 of gearbox) and clean away any excess oil.
 5. Grease (with a grade II type tube grease), the following zerks:
 - Tailwheel, wheel fork (See Figure M-1)
 - Tailwheel fork (See Figure M-1)
 - Both U-joints on the PTO shaft (See Figure M-2)
 6. Inspect all guards to insure they are in good working order. If not replace before using.
 7. Check all bolts, nuts and belt to insure they are tight and secure.

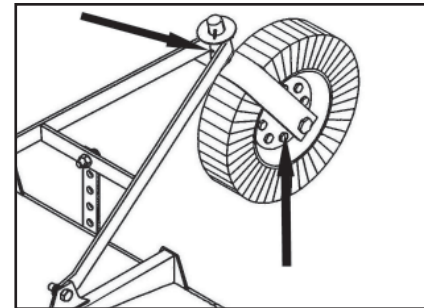

Figure M-1 Grease Points

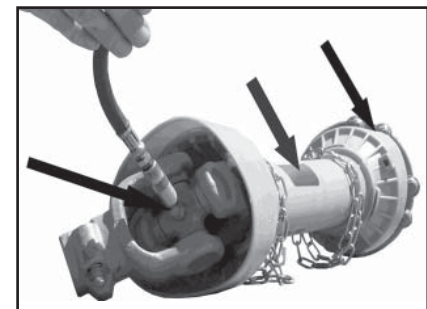
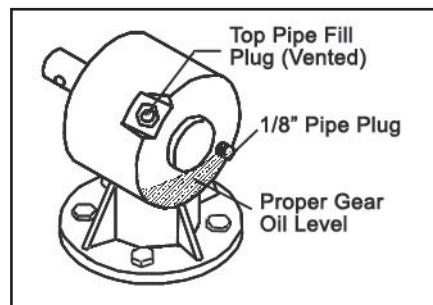

Figure M-2 U-joints



CAUTION: DO NOT over fill gearbox. This could cause damage to oil seals and can cause permanent damage to the gearbox. This issue will not be covered under warranty.

4.3 ATTACHING TO TRACTOR



WARNING - NEVER STAND BETWEEN TRACTOR AND ROTARY MOWER WHILE BACKING UP TRACTOR TO THE HITCH.

1. Attach to tractor's category 1, 3-point hitch as described in the Tractor's Operator's Manual.



WARNING - FAILURE TO INSTALL RETAINING CLIP ON GEARBOX INPUT SHAFT WOULD ALLOW DRIVELINE TO SWING FREELY IF BOLT IS SHEARED CAUSING POSSIBLE INJURY OR DEATH.

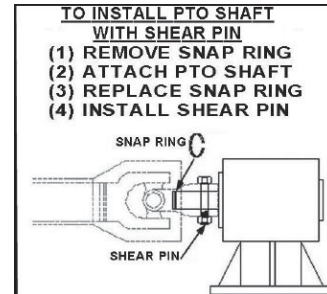

2. Determine if the PTO shaft needs to be shortened.

NOTE: Due to the many variations in the tractor hitch points and distances between equipment gearbox input shaft and tractor PTO output shafts, some combinations may require PTO shafts to be shortened as described by the following steps.

3. Raise and lower rotary mower in order to locate the shortest distance between equipment gearbox input shaft and tractor PTO output shaft. With the rotary mower in the shortest distance position shut down the tractor and **SECURELY BLOCK ROTARY MOWER IN POSITION.**
4. Pull apart PTO shaft and attach outer section to tractor PTO output shaft.

NOTE: Be sure to pull on PTO shaft section to ensure yoke has locked into place.

5. Place and hold inner PTO shaft section next to outer section and check if PTO shaft is too long. Each section should end approximately 3 inches short of reaching u-joint shield on the opposite section. If the shaft is too long measure 3 inches back from each u-joint shield and mark the other shaft section. Be sure to do this for both PTO shaft halves.

NOTE: Do not cut PTO shaft sections at this time.

6. Raise rotary mower and remove blocking. Raise and lower rotary mower in order to locate the longest distance between equipment input shaft and the tractor PTO output shaft. With the rotary mower in the longest distance position, shut down the tractor and **SECURELY BLOCK THE ROTARY MOWER IN POSITION.**
7. As in step 5 hold PTO shaft sections together and check for a minimum of 6 inches of overlap. If PTO shaft has been marked for cutting the overlap is the distance measured between the two marks. If the PTO shaft has less than a 6 inch overlap, **DO NOT USE.** Contact your authorized dealer.

NOTE: If the PTO shaft length is too long go to ***SIZING PTO SHAFT*** (Page 15).

8. Apply any multi-purpose grease to the outside of the male (inner) PTO shaft section. Assemble PTO shaft and install on rotary mower and tractor.

NOTE: If you shear the bolt that attaches the PTO shaft to the gearbox replace with a grade 2 bolt only. Replacement with another grade of bolt will void your warranty and may cause terminal damage to the PTO shaft, gearbox, or tractor. (Shear pin 5 pack - part no. 500101)



WARNING - FAILURE TO INSTALL RETAINING CLIP ON GEARBOX INPUT SHAFT WOULD ALLOW DRIVELINE TO SWING FREELY IF BOLT IS SHEARED CAUSING POSSIBLE INJURY OR DEATH.

9. Pull on tractor side of PTO shaft yoke to be sure it has locked in place. Make certain PTO shaft shielding is in place and good working condition.
10. The PTO shaft shield is a non-rotating design and must be secured prior to equipment use. Using the chain on each yoke shield attach to a fixed object on the tractor and equipment ends that will not allow the PTO shaft shield to rotate during operation.

4.4 SIZING PTO SHAFT

1. Cutting the PTO shaft to length.

NOTE: Be sure to cut equal lengths of each PTO shaft section. Clamp end of PTO shaft in a vice and cut off shield where marked. (*Figure 1-A and 1-B*).

2. Using cut section of the shield as a guide cut shaft off the same amount. (*Figure 2*)
3. Repeat steps 1 and 2 for other PTO shaft section.

4. Use a file to deburr PTO shafts. Clean up all chips, burrs, and filings from both ends of the PTO shaft.

NOTE: If you shear the bolt that attaches the PTO shaft to the gearbox replace with a grade 2 bolt only. Replacement with another grade of bolt will void your warranty and may cause terminal damage to the PTO shaft, gearbox, or tractor.



Figure 1-A

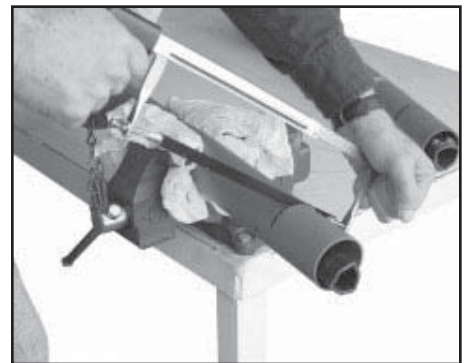

Figure 1-B



Figure 2

5 OPERATING INSTRUCTIONS

This mower was designed to **CUT PASTURE GRASS AND ROUGH AREAS UP TO 1 INCH IN DIAMETER.** Use of your rotary mower to cut any material larger than 1" in diameter may damage the mower and void your warranty.

5.1 PRE-OPERATIONAL ADJUSTMENTS

Set tractor's lift control stop at a position that will prevent the PTO shaft from coming in contact with the front edge of the mower when it is at full lift. Consult your tractor manual for instructions.

5.2 CUTTING HEIGHT ADJUSTMENT

To prevent mower blades from striking the ground or hidden objects, your mower should be set to the highest position that will give the desired cutting height. By setting your mower up this way you reduce blade wear and stress to the mower. Mowing at regular intervals will yield far better results than periodic mowing (i.e. less wind rowing).

To adjust cutting heights follow these steps:

1. Raise rotary mower off the ground with the tractor and **SECURELY BLOCK IN POSITION.** Remove $\frac{5}{8}$ " bolt from adjusting bracket. (See *Figure K*).
2. Move the A-frame tailwheel up or down to desired cutting height. Re-install $\frac{5}{8}$ " bolt and tighten to secure in position. (See *Figure L*)

NOTE: It may be necessary to loosen the A-frame tailwheel attachment bolts. (See *Figure L*) as shown by the arrow.

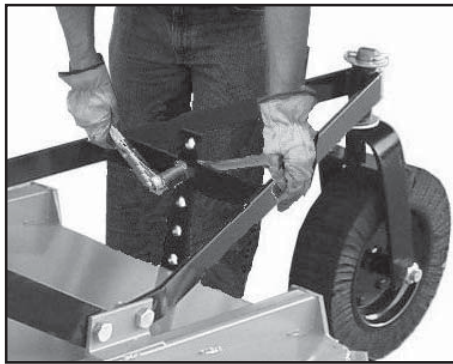

Figure K

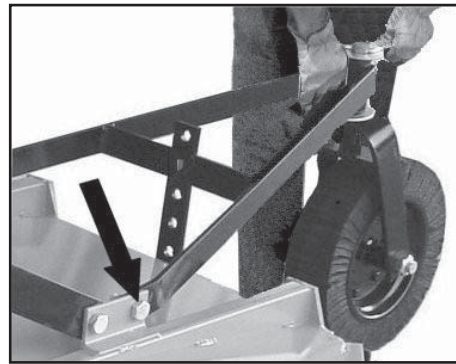

Figure L

NOTE: For best results in heavier cutting conditions adjust the deck so the rear of the mower is approximately 2" higher than the front. This method requires less horsepower and ground speeds of approximately 3 to 5 MPH. If finer shredding results are desired, adjust the deck to level or slightly lower in the rear. This method will keep foliage under the deck longer resulting in finer pieces. The down side of this method is it takes a lot more horsepower and very slow ground speed. This method is not recommended unless a **PTO speed of 540 RPM** can be maintained.

5.3 ROTARY MOWER OPERATION

STEP 1:

Before each use, perform the maintenance described in maintenance section. (Page 18)

STEP 2:

Read, understand, and follow all the information on safety training, preparation, starting and stopping safety, operational safety, and transport safety warning sections of this manual.

STEP 3:

With tractor running, lower rotary mower into working position.

STEP 4:

With the tractor at idle RPM, engage PTO and slowly advance throttle to 540 PTO RPM.

NOTE: Rotary mower designed to run at **540 PTO RPM only**.

STEP 5:

Select a low gear for the tractor and begin to mow. Tractor ground speed is to be controlled by gear selection only and not engine speed. Tractor ground speed should allow rotary mower to maintain 540 PTO RPM and thus maximum blade tip speed.

NOTE: Do not allow the tractor engine or rotary mower to bog down or stall. This causes undue wear and tear on the mower and tractor. If this continues to happen reduce ground speed and raise cutting height of rotary mower until the **540 PTO RPM** is able to be maintained.



**NEVER ATTEMPT TO CLEAN OUT A PLUGGED DISCHARGE CHUTE
UNTIL THE TRACTOR HAS BEEN SHUT DOWN AND THE MOWER BLADES
HAVE COMPLETELY STOPPED.**

STEP 6:

After each use, clean all debris from the top and bottom of the rotary mower. Replace any missing or illegible safety decals. Inspect for any damaged or worn parts and replace before next use. Store rotary mower in a dry environment.

6 MAINTENANCE

1. Periodically check and maintain proper gear oil level.
2. **Every 8 hours** grease wheel fork(s), wheel hub(s), PTO shaft universal joints (2), and PTO telescoping surface. (See Figures M-1 and M-2)

NOTE: Use only a grade Type II tube grease.

3. Before each use check to make sure all safety features are installed and working properly.
4. Keep blades sharp and balanced at all times. When replacing blades, replace all blades and blade bolts at the same time.
5. Periodically check all nuts and bolts to insure they are tight and secure.

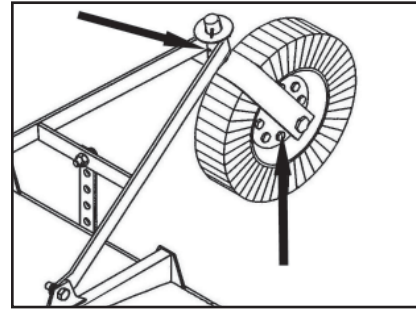

Figure M-1 Grease Points

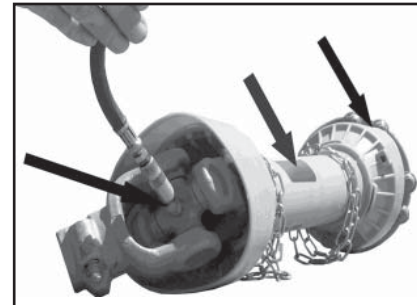

Figure M-2 U-joints

6.1 SERVICE RECORD

See Maintenance section for details of service.
Copy this page to continue record.

ACTION CODE: G = GREASE CL = CLEAN

MAINTENANCE	HOURS											
	SERVICED BY											
DAILY OR 8 HOURS												
GR-Wheel Fork(s) & Hub(s)												
GR-PTO Shaft Universal Joints												
GR-PTO Telescoping Surface												
ANNUALLY												
CL-Machine												

7 REPLACEMENT PARTS

7.1 FLEX HITCH ROTARY MOWER

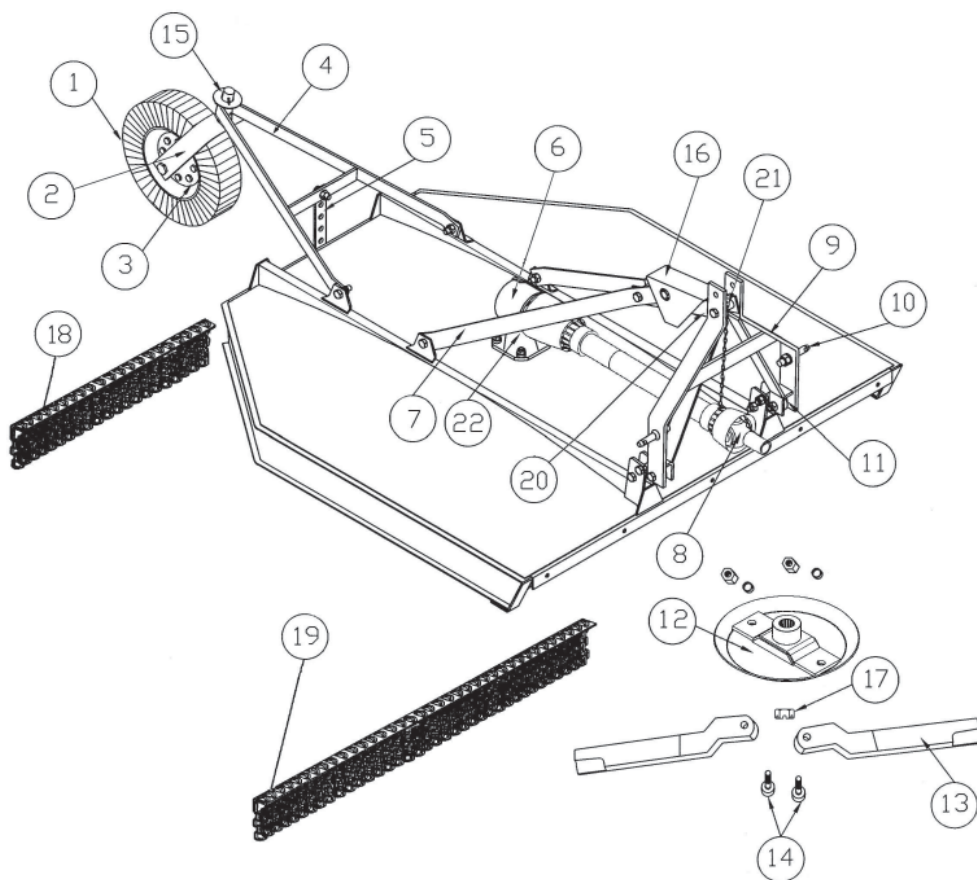

REF #	PART NO.			DESCRIPTION
	4 Foot	5 Foot	6 Foot	
1	403001	403001	403001	Tire & Rim w/Hub
2	403019	403019	403019	Wheel Fork Assembly
3	191100	191100	191100	Wheel Hub Assembly
4	401024	401024	401009	A-Frame Assembly
5	310099	310099	310099	A-Frame Height Adjustment
6	184005	184005	184005	Gearbox
7	360685	310060	310060	Lift Arm Brace
8	147029	147234	147242	PTO Shaft
9	403661	403663	403663	Lift Arm Assy
10	500001	500001	500001	Cat. 1 Lift Pins (Pkg. 2)
11	502010	502010	502010	Swivel Link Set (Pkg. 2)
12	403031	403031	403034	Stump Jumper
13	501118	501124	501130	Mower Blade Set (Pkg. 2)
14	501001	501001	501001	Blade Bolt Set (Pkg. 2)
15	501013	501013	501013	Wheel Washer Kit
16	501029	501029	501029	Pivot Shield Kit
17	501110	501110	501110	Castle Nut and Cotter Pin Pkg.
18	403971	403973	403975	Rear Chain Guard (Optional)
19	403970	403972	403974	Front Chain Guard (Optional)
20	401031	401031	401031	Pivot Bar
21	501095	501095	501095	Spacer and Bolt Kit
22	500101	500101	500101	Shear Bolt Kit (Pkg. 5)

7.2 SHEAR PIN PTO SHAFT

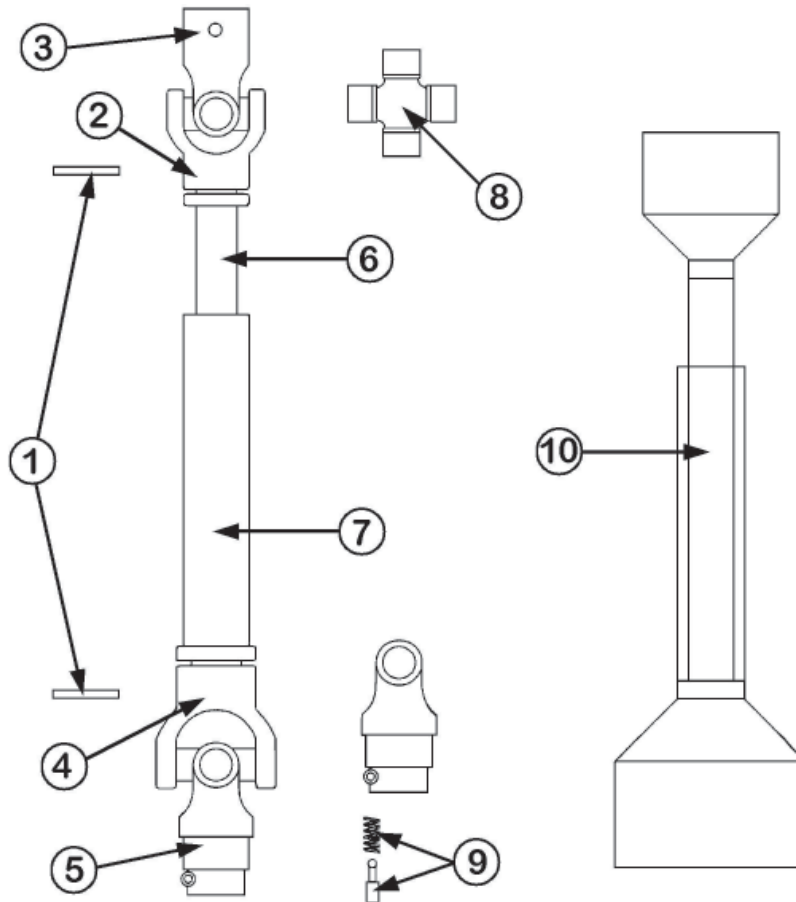

REF #	PART NO.	DESCRIPTION
1	500131	Roll Pin Kit (2 Pk., (1) 8 x 55 mm, (1) 8 x 60 mm)
2	151045	Male Tube End Yoke
3	151040	Implement End Yoke
4	151050	Female Tube End Yoke
5	151035	Tractor End Yoke
6	151090	Inner Tube 14 Series
7	151091	Outer Tube 14 Series
8	170015	Cross Kit #4
9	170110	Quick Disconnect Pin
10	124310	Safety Shield BYPY
10	124311	Safety Shield Eurocardan

7.3 SLIP CLUTCH PTO SHAFT

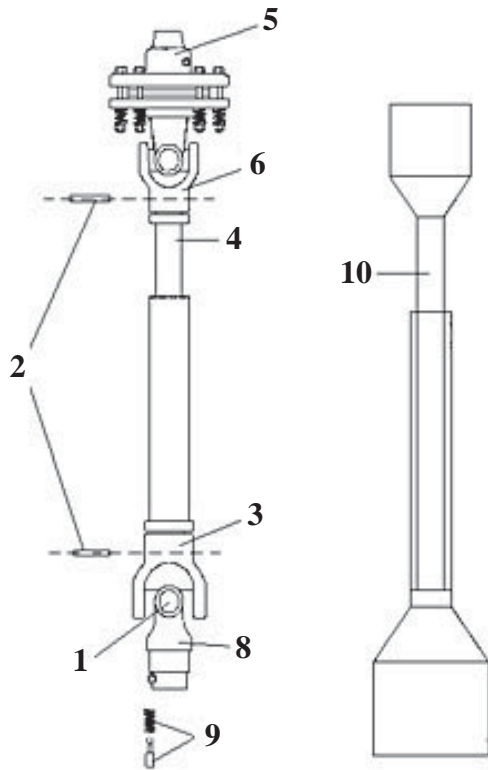

<u>REF #</u>	<u>PART NO.</u>	<u>DESCRIPTION</u>
1	170020	Cross Kit
2	170120	Roll Pin
3	151070	Female Tube End Yoke
4	151092	Inner Tube
5		Slip Clutch Assy
6	151065	Male Tube End Yoke
7	151093	Outer Tube
8	151055	Tractor End Yoke
9	170110	Quick Disconnect Pin
10	124315	Safety Shield BYPY
10	124316	Safety Shield Eurocardan

7.4 SLIP CLUTCH ASSEMBLY

<u>REF #</u>	<u>PART NO.</u>	<u>DESCRIPTION</u>
1	500140	Clutch Spring with Compression Bolts (Pkg. 8)
2	196006	Flanged Yoke (7")
2	196011	Flanged Yoke (8")
3	196005	Sleeve
4	196008	Clutch Plate (7")
4	196003	Clutch Plate (8")
5	196004	Friction Hub (7")
5	196007	Friction Hub (8")
6	147350	Slip Clutch Lock Bolt
7	196002	Slip Clutch Liner Plate (7")
7	195998	Slip Clutch Liner Plate (8")
8	196001	Pressure Plate (7")
8	196015	Pressure Plate (8")

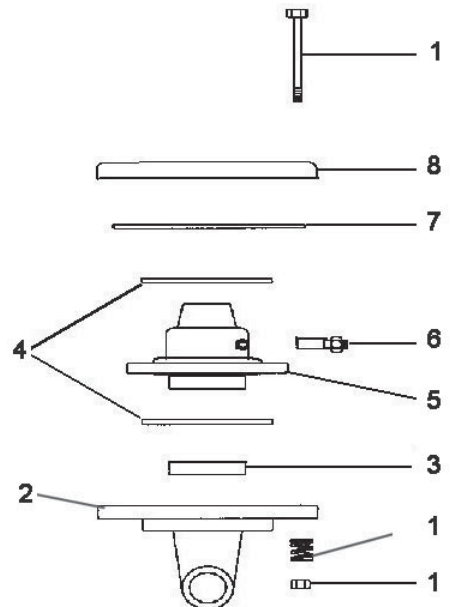

7.5 PTO SHAFTS COVER REMOVAL

BONDIOLI - (BYPY)

1. There are 3 white tabs around the cover as shown in (Ref. A, Figure 1). Take a screwdriver and press against the tabs one at a time with downward angular pressure toward the end of shaft marked (Ref. B, Figure 2). As you are pressing tab grasp cover at point marked (Ref. B, Figure 2) and apply pressure against cover in the direction of arrow, do this for each tab. (Sometimes the other tabs may relock, if they do you must repeat unlock procedure.) You will feel it click when the tab releases, after all 3 tabs are released you can slide the cover down the shaft in direction of (Ref. C, Figure 2).
2. To put cover back into place slide cover back toward end until all the tabs relock. (You may have to tap lightly with screwdriver or hammer handle).

NOTE: Cover may be longer on some models but, they will come off the same as above.

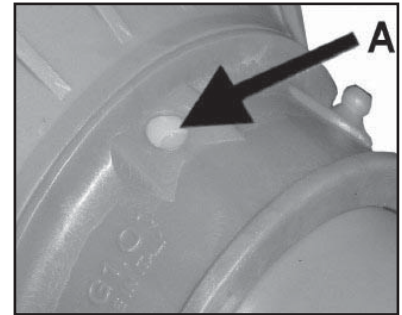

Figure 1

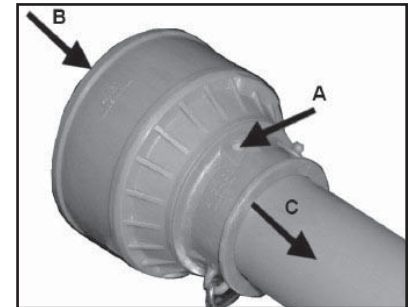

Figure 2

EUROCARDAN SERIES 4

1. First you must locate the black tab (Ref. D, Figure 3) put flat screwdriver in slot in end of tab and turn until the flat side is pointing towards center of shaft. Once you do this take the thin flat screwdriver and put into slot labelled (Ref. E, Figure 3) pry tab all the way out as shown in (Figure 3).
2. There are 3 white tabs around the cover as shown in (Ref. G, Figure 4). You must line up cover slots and tabs (as shown in Figure 4, Ref. F & G). Take a screwdriver and press against the tabs one at a time with downward angular pressure toward the end of shaft. As you are pressing tab grasp cover and apply pressure against cover in the direction of arrow, (Ref. H, Figure 3). Do this for each tab. (Sometimes the other tabs may relock, if they do you must repeat unlock procedure.) You will feel it click when the tab releases, after all 3 tabs are released you can slide the cover down the shaft in direction of (Ref. H, Figure 3).
3. To put cover back into place slide cover back toward end (be sure tabs and slots line up) until all the tabs relock. (You may have to tap lightly with screwdriver or hammer handle). Once they have relocked, replace black tab that was removed with flat side toward shaft center then turn flat side up to lock in place.

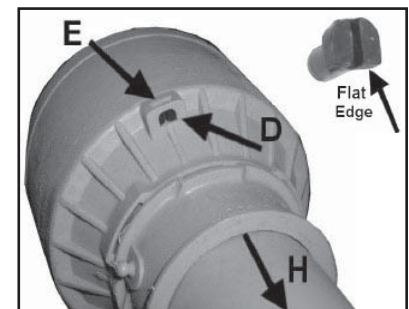

Figure 3

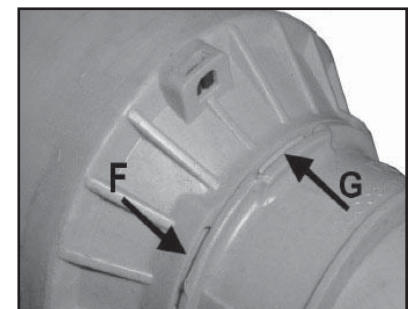

Figure 4

LA MAGDALENA

1. There are 3 black tabs around the cover (Ref. K, Figure 5). Take a screwdriver and press against the tabs one at a time with downward angular pressure toward the end of shaft marked (Ref. J, Figure 5). As you are pressing tab grasp cover at point marked (Ref. J, Figure 5) and apply pressure against cover in the direction of arrow, do this for each tab.
2. To replace, slide cover back toward end and line up black tabs with the holes and lock in place.

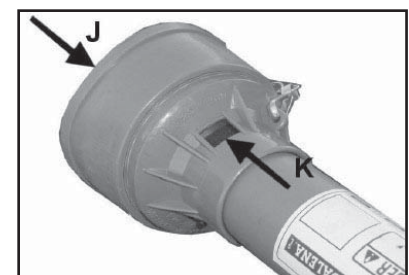

Figure 5

EUROCARDAN SERIES 5

1. There are 2 black tabs around the cover as shown in (Ref. B, Figure 1). Take a flat screwdriver and pry under the tabs one at a time at point (Ref. B, Figure 2) lifting tab over on top of (e-shaped lock). After both tabs are released you can slide the locking ring down the shaft in direction of (Ref. C, Figure 3). Then you will see a metal e-ring (Ref. E, Figure 4) at point (Ref. D, Figure 4) you must pry under ring and remove it, (it will just slide down shaft unless you take PTO apart) then apply pressure against cover (Ref. A, Figure 1) in the direction of arrow and slide cover down shaft.
2. To put cover back into place, slide cover back toward end, making sure cover and locking mechanism (Ref. F, Figure 4) line up. Replace metal e-ring, slide the locking ring back into place, be sure the tabs lock securely over locks.

NOTE: Cover may be longer on some models but they will come off the same as above.

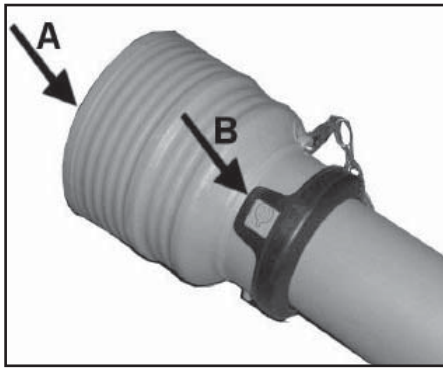

Figure 1

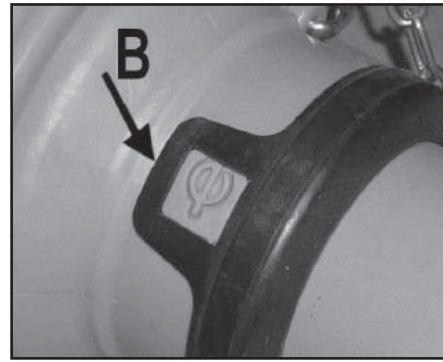

Figure 2

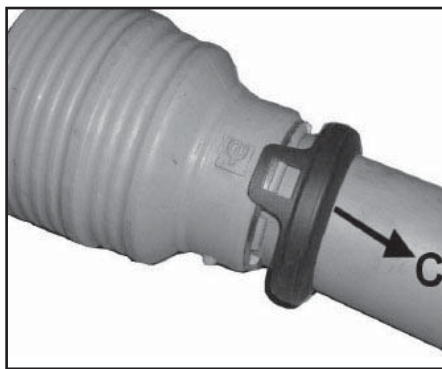

Figure 3

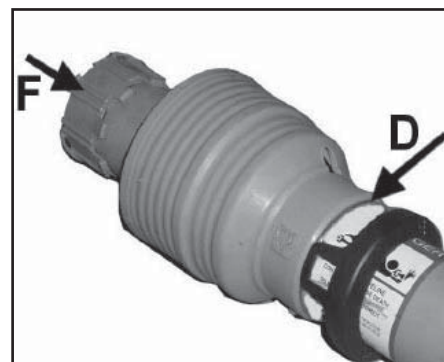
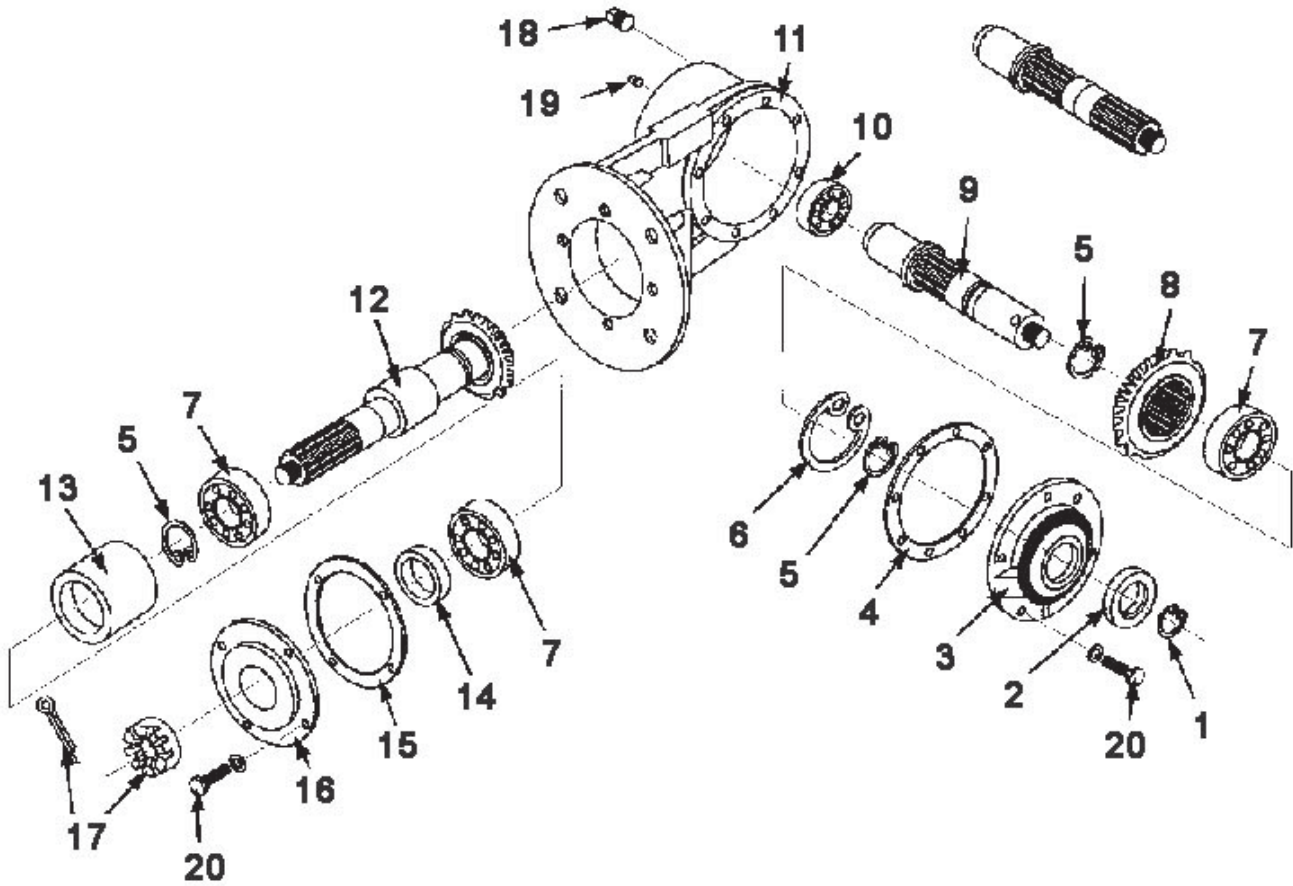

Figure 4

7.6 40 HORSEPOWER GEARBOX



REF #	GEARBOX			DESCRIPTION
	184000	184005	184010	
1	106138	106138	106138	Snap Ring
2	156010	156010	156010	Input Seal (NAK 35 x 54 x 10)
3	129015	129015	129015	Front Cap
4	124130	124130	124130	Front Cap Gasket
5	131031	131031	131031	Snap Ring
6	131030	131030	131030	Snap Ring
7	155005	155005	155005	Bearing (Hoover 208)
8	185007	185010	185010	Input Gear
9	186010	186010	186005	Input Shaft
10	155010	155010	155010	Baring (NSK 6207)
11	129010	129010	129010	Housing
12	185005	185006	185006	Output Shaft
13	-	131045	131045	Spacer
14	156005	156005	156005	Output Seal (NAK 40 x 54 x 7)
15	124131	124131	124131	Bottom Cap Gasket
16	129005	129005	129005	Bottom Cap
17	501110	501110	501110	1" Castle Nut w/Washer & Cotter Pin
18	131035	131035	131035	½" Pipe Plug
19	131040	131040	131040	⅜" Pipe Plug
20	-	-	-	⅜" x 1" Bolt & Lock Washer

8 LIMITED WARRANTY



GEARMORE, INC., warrants each new Gearmore product to be free from defects in material and workmanship for a period of twelve (12) months from date of purchase to the original purchaser. This warranty shall not apply to implements or parts that have been subject to misuse, negligence, accident, or that have been altered in any way.

Our obligation shall be limited to repairing or replacement of any part, provided that such part is returned within thirty (30) days from date of failure to Gearmore through the dealer from whom the purchase was made, transportation charges prepaid.

This warranty shall not be interpreted to render us liable for injury or damages of any kind or nature, direct, consequential or contingent, to person or property. This warranty does not extend to loss of crops, loss because of delay in harvesting or any other expenses, for any other reasons.

Gearmore in no way warrants engines, tires, or other trade accessories, since these items are warranted separately by these respective manufacturers.

Gearmore reserves the right to make improvements in design or changes in specification at any time, without incurring any obligations to owners or units previously sold.

Please be advised that all warranty work done by your dealer must be approved by Gearmore before work begins.

GEARMORE, INC.
13477 Benson Ave.
Chino, CA 91710

Always refer to and heed machine operating warning decals on machine.

*To insure warranty, please fill out the enclosed warranty form
and return to Gearmore via mail.*