

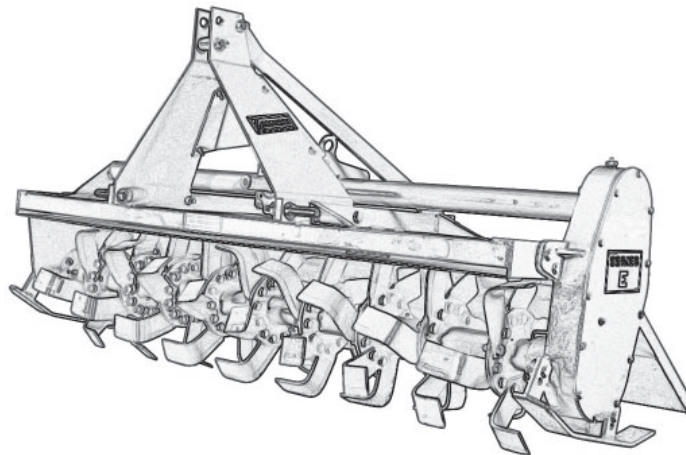

ROTARY TILLERS



**Operation, Service
& Parts Manual
For Models:
"E" Series**

May 2011

TABLE OF CONTENTS

<u>SECTION</u>	<u>DESCRIPTION</u>	<u>PAGE</u>
1	Introduction	1
1.1	Purchaser's Responsibility	1
2	Safety	2- 10
2.1	General Safety	3
2.2	Equipment Safety Guidelines	4
2.3	Safety Training	5
2.4	Safety Signs	5
2.5	Safety Sign Locations	6 - 7
2.6	Preparation	8
2.7	Operational Safety	8 - 9
2.8	Transport Safety	10
2.9	Storage Safety	10
2.10	Maintenance Safety	10
3	Set-Up & Assembly	11 - 14
3.1	Assembly Instructions	11
3.2	Before Putting In Service	11 - 12
3.3	Attaching To Tractor	13
3.4	Sizing PTO Shaft	14
4	Operating Instructions	15
4.1	End of Season	15
5	Maintenance	16
6	Specifications	16
7	Replacement Parts	17 - 22
7.1	Ordering Parts	17
7.2	Tiller	17 - 18
7.3	PTO 147122	19
7.4	Outboard Hub 184070	20
7.5	Gearbox 184069	21
7.6	Top Gearbox Assembly	22
8	Limited Warranty	23

1 INTRODUCTION

This manual contains valuable information about your new Gearmore Rotary Tiller. It has been carefully prepared to give you helpful suggestions for operating, adjusting, servicing and ordering repair parts.

Keep this manual in a convenient place for quick and easy reference. Study it carefully. you have purchased a dependable and sturdy tiller, but only by proper care and operation can you expect to receive the service and long life designed and built into it.

Sometime in the future your tiller may need new parts to replace those that are worn or broken. If so, go to your dealer and provide him with the model and part number.

OPERATOR ORIENTATION - The directions left, right, front and rear, as mentioned throughout this manual, are as seen from the driver's seat and facing in the direction of travel.

1.1 PURCHASER'S RESPONSIBILITY

It is the responsibility of the purchaser and/or operator to.....

- Read and understand the information contained in this manual.
- Operate, lubricate, assemble and maintain the equipment in accordance with all instructions and safety procedures in this manual.
- Inspect the equipment and replace or repair any parts that are damaged or worn which under continued operation would cause damage, wear to other parts, or cause a safety hazard.
- Return the equipment or parts to the authorized Gearmore dealer, from where it was purchased, for service or replacement of defective parts that are covered by warranty.
- Payment of all costs incurred by the dealer for traveling to or transporting the equipment for warranty inspection and or claims.

NAME: _____

PURCHASED FROM: _____

DATE OF PURCHASE: _____

MODEL NUMBER: _____

SERIAL NUMBER: _____

2 SAFETY

SAFETY ALERT SYMBOL

This Safety Alert symbol means **ATTENTION! BECOME ALERT! YOUR SAFETY IS INVOLVED!**

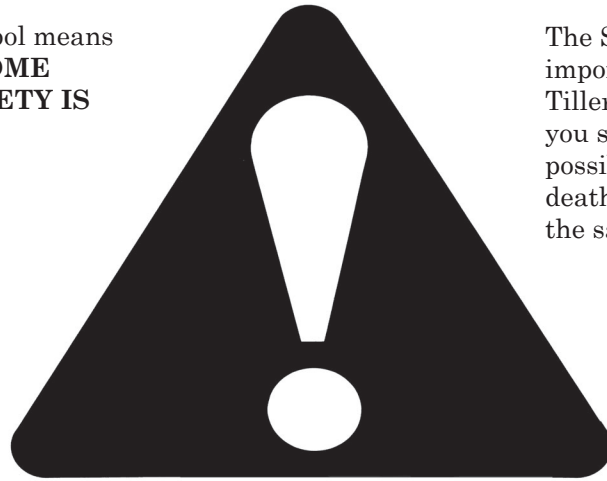

The Safety Alert symbol identifies important safety messages on the Tiller and in the manual. When you see this symbol, be alert to the possibility of personal injury or death. Follow the instructions in the safety message.

Why is SAFETY important to you?

3 Big Reasons

Accidents Disable and Kill
Accidents Cost
Accidents Can Be Avoided

SIGNAL WORDS:

Note the use of the signal words **DANGER**, **WARNING** and **CAUTION** with the safety messages. The appropriate signal word for each message has been selected using the following guide-lines:

SI NO LEE INGLES, PIDA AYUDA A AIGUIEN QUE SI LO LEA PARA QUE LE TRADUZCA LAS MIDIDAS DE SEGURIDAD.

DANGER - Indicates an imminently hazardous situation that, if not avoided, will result in death or serious injury. This signal word is to be limited to the most extreme situations typically for machine components which, for functional purposes, cannot be guarded.

WARNING - Indicates a potentially hazardous situation that, if not avoided, could result in death or serious injury, and includes hazards that are exposed when guards are removed. It may also be used to alert against unsafe practices.

CAUTION - Indicates a potentially hazardous situation that, if not avoided, may result in minor or moderate injury. It may also be used to alert against unsafe practices.

Read and follow the instructions in this manual and especially in the safety section. Failure to do so can result in serious injury or death.

If you have any questions not answered in this manual or require additional copies or the manual is damaged, please contact your dealer.

2.1 GENERAL SAFETY

YOU are responsible for the **SAFE** operation and maintenance of your tiller. **YOU** must ensure that you and anyone else who is going to operate, maintain or work around the tiller be familiar with the operating and maintenance procedures and related **SAFETY** information contained in this manual. This manual will take you step-by-step through your working day and alerts you to all good safety practices that should be adhered to while operating the tiller.

Remember, **YOU** are the key to safety. Good safety practices not only protect you, but also the people around you. Make these practices a working part of your safety program. Be certain that **EVERYONE** operating this equipment is familiar with the recommended operating and maintenance procedures and follows all the safety precautions. Most accidents can be prevented. Do not risk injury or death by ignoring good safety practices.

- Tiller owners must give operating instructions to operators or employees before allowing them to operate the machine, and at least annually there after per OSHA (Occupational Safety and Health Administration) regulation 1928.57.
- The most important safety feature on this equipment is a **SAFE** operator. It is the operator's responsibility to read and understand **ALL** Safety and Operating instructions in the manual and to follow these. Most accidents can be avoided.
- A person who has not read and understood all operating and safety instructions is not qualified to operate the machine. An untrained operator exposes himself and bystanders to possible serious injury or death.
- **DO NOT** modify the equipment in any way. Unauthorized modification may impair the function and/or safety and could affect the life of the equipment.
- **Think SAFETY! Work SAFELY!**

1. Read and understand the Operator's Manual and all safety signs before operating, maintaining, or adjusting the tiller.



2. Have a first-aid kit available for use should the need arise and know how to use it.



3. Have a fire extinguisher available for use should the need arise and know how to use it.



4. Wear appropriate protective gear. This list includes but is not limited to:

- A hard hat
- Protective shoes with slip resistant soles
- Protective goggles, glasses or face shield
- Heavy gloves
- Protective clothing

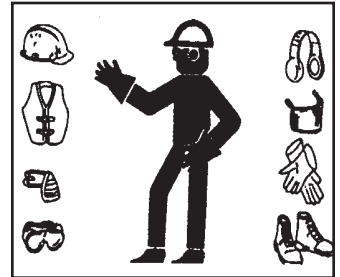

5. Install and secure all guards before starting.

6. **DO NOT** allow riders.

7. Wear suitable ear protection for prolonged exposure to excessive noise.



8. Place all controls in neutral, stop tractor engine, set park brake, remove ignition key and wait for all moving parts to stop before servicing, adjusting, repairing, or unplugging.

9. Clear the area of people, especially small children, before starting.

10. Review safety related items annually with all personnel who will be operating or maintaining the tiller.

2.2 EQUIPMENT SAFETY GUIDELINES

Safety of the operator and bystanders is one of the main concerns in designing and developing a tiller. However, every year accidents occur which could have been avoided by a few seconds of thought and a more careful approach to handling equipment. You, the operator, can avoid many accidents by observing the following precautions and insist those working with you, or for you, follow them.

FAILURE TO FOLLOW ALL SAFETY INSTRUCTIONS COULD RESULT IN SERIOUS INJURY OR DEATH!

- In order to provide a better view, certain photographs or illustrations in this manual may show an assembly with a safety shield removed. However, equipment should **never** be operated in this condition. Keep all shields in place. If shield removal becomes necessary for repairs, replace the shield prior to use.
- Replace any safety sign or instruction sign that is not readable or is missing. Location of such safety signs are indicated in this manual.
- **NEVER** use alcoholic beverages or drugs which can hinder alertness or coordination while operating this equipment. Consult your doctor about operating this machine while taking prescription medications.
- **Under no circumstances should young children be allowed to work with this equipment. Do not allow persons to operate or assemble this unit until they have read this manual and have developed a thorough understanding of the safety precautions and of how it works. Review the safety instructions with all users annually.**

- This equipment is dangerous to children and persons unfamiliar with its operation. The operator should be a responsible, properly trained and physically able person familiar with farm machinery and trained in this equipment's operations. If the elderly are assisting with farm work, their physical limitations need to be recognized and accommodated.
- Use a tractor equipped with a Roll Over Protective Structure (ROPS) and a seat belt.
- **NEVER** exceed the limits of a piece of machinery. If its ability to do a job, or to do so safely, is in question - **DON'T TRY IT.**
- Do not modify the equipment in any way. Unauthorized modification may impair the function and/or safety and could affect the life of the equipment.
- When repairing or lubricating this piece of equipment, always shut off power before going near the machine.
- **DO NOT** use this product while using drugs or alcoholic beverages.

In addition to the design and configuration of this implement, including Safety Signs and Safety Equipment, hazard control and accident prevention are dependent upon the awareness, concern, prudence and proper training of personnel involved in the operation, transport, maintenance and storage of the machine.

Refer also to safety messages and operation instructions in each of the appropriate sections of the tractor and tiller manuals. Pay close attention to the safety signs affixed to the tractor and the tiller.

Think SAFETY! Work SAFELY!

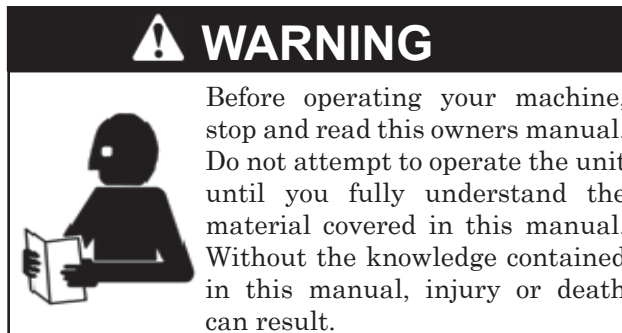

2.3 SAFETY TRAINING

Safety is a primary concern in the design and manufacture of our products. Unfortunately, our efforts to provide safe equipment can be wiped out by a single careless act of an operator or bystander.

In addition to the design and configuration of equipment, hazard control and accident prevention are dependent upon the awareness, concern, prudence and proper training of personnel involved in the operation, transport, maintenance and storage of this equipment.

It has been said, "*The best safety feature is an informed, careful operator.*" We ask you to be that kind of an operator. It is the operator's responsibility to read and understand ALL Safety and Operating instructions in the manual and to follow these. Accidents can be avoided.



Working with unfamiliar equipment can lead to careless injuries. Read this manual, and the manual for your tractor, before assembly or operating, to acquaint yourself with the machines. If this machine is used by any person other than yourself, or is loaned or rented, it is the machine owner's responsibility to make certain that the operator, prior to operating:

- a. Reads and understands the operator's manuals.
- b. Is instructed in safe and proper use.

Should ownership of the equipment be transferred, this manual must also be transferred.

Know your controls and how to stop tractor, engine and machine quickly in an emergency. Read this manual and the one provided with your tractor.

Train all new personnel and review instructions frequently with existing workers. Be certain only a properly trained and physically able person will operate the machinery. A person who has not read and understood all operating and safety instructions is not qualified to operate the machine. An untrained operator exposes himself and bystanders to possible serious injury or death. If the elderly are assisting with farm work, their physical limitations need to be recognized and accommodated.

For any part of this manual that you do not understand, contact your dealer or Gearmore, Inc.

2.4 SAFETY SIGNS

Safety decals and this manual must be considered a permanent part of your equipment. Keep safety signs clean and legible at all times. **ALWAYS** observe and follow all safety instructions on the decals. Replace safety signs that are missing or have become illegible. Replaced parts that displayed a safety sign should also display the current sign.

Safety signs are available from your authorized dealer or from Gearmore.

- **DO NOT** operate tiller with more than one person on the tractor.
- **DO NOT** operate close to a ditch or stream. **Drive slowly** over rough ground.
- Disengage PTO and shut off tractor before getting out of tractor or making any adjustments to tiller. **NEVER** walk or stand behind the tiller while it is in operation. **ALWAYS** wait for all moving parts to come to a complete stop before leaving the tractor or attempting to work on the tiller.
- **DO NOT** work underneath the tiller without first blocking it up safely using sufficient and approved stands. **NEVER** work on tiller without first unhooking the PTO and properly blocking the tiller in place.
- Engage PTO slowly to prevent damage. **NEVER** engage PTO when people are close. Keep everyone clear from tiller when starting and when operating. Keep clear of all rotating parts, including driveline and drive shafts. **ALWAYS** make sure shields on driveline and drive shafts rotate freely prior to engaging PTO. **NEVER** allow PTO shaft to bottom out or extend too far apart, serious damage to PTO, tractor and gearbox can occur.

2.5 SAFETY SIGN LOCATIONS

The types of safety signs and locations on the equipment are shown in the illustration below. Good safety requires that you familiarize yourself with the various safety signs, the type of warning and the area, or particular function related to that area, that requires your **SAFETY AWARENESS**.

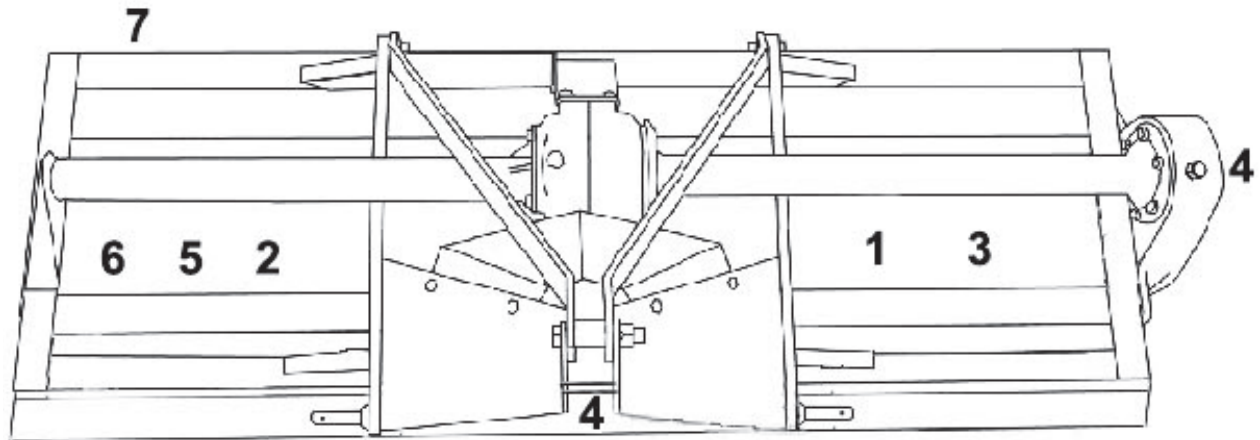

TOP VIEW

NOTE: The numbers represent the safety decals below and on the following page.

REMEMBER: If safety signs have been damaged, removed, become illegible or parts have been replaced without signs, new safety signs must be applied. New safety signs are available from your authorized Gearmore dealer.



WARNING

To prevent serious injury or death:

Si no lee ingles, pida ayuda a alguien que si lo lea para que le traduzca las medidas de seguridad

- Read and understand the Operator's Manual before using. Review annually.
- Do not permit riders on the tractor or tiller, including children.
- Do not allow children to operate tiller.
- Operate only with guards installed and in good working condition.
- Keep away from moving parts.
- Operate only with tractor equipped with ROPS and seatbelts.
- Before tilling, clear debris from tilling area.
- Do not operate in the raised position.
- Stop engine, lower tiller, set brake and wait for all moving parts to stop before dismounting.
- Support tiller securely before working beneath unit.
- Transport with clean reflectors, SMV and working lights as required by federal, state, and local laws.
- Keep yourself, others, and clothing away from the rotating PTO.
- Keep others away from area to be tilled to avoid injury from flying objects.
- Do not stand between tractor and tiller.
- Be careful on uneven terrain. Decrease speed when turning.
- Do not exceed a safe transport speed.

2.5 SAFETY SIGN LOCATIONS (Continued)



No. 2



No. 3



No. 4



No. 7



No. 5

2.6 PREPARATION

1. Never operate the tractor and tiller until you have read and completely understand this manual, the Tractor Operator's Manual and each of the Safety Messages found on the safety signs on the tractor and tiller.

2. Personal protection equipment, including hard hat, safety glasses, safety shoes and gloves are recommended during assembly, installation, operation, adjustment, maintaining, repairing, removal or moving the implement. **DO NOT** allow long hair, loose fitting clothing or jewelry to be around equipment.

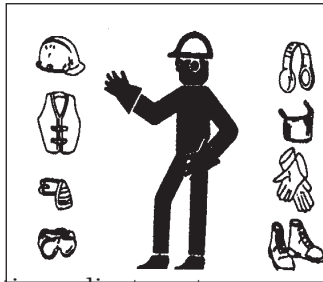

3. **PROLONGED EXPOSURE TO LOUD NOISE MAY CAUSE PERMANENT HEARING LOSS!**

Tractors with or without equipment attached can often be noisy enough to cause permanent, partial hearing loss. We recommend that you wear hearing protection on a full-time basis if the noise in the Operator's position exceeds 80db. Noise over 80db on a long-term basis can cause severe hearing loss. Noise over 90db adjacent to the Operator over a long-term basis may cause permanent, total hearing loss.



NOTE: Hearing loss from loud noise (from tractors, chain saws, radios, and other such sources close to the ear) is cumulative over a lifetime without hope of natural recovery.

4. Clear area to be tilled of stones, branches or other debris that might be thrown or entangled in the tiller, causing injury or damage.
5. Operate only in daylight or good artificial light.
6. Ensure tiller is properly mounted, adjusted and in good operating condition.
7. Ensure that all safety shielding and safety signs are properly installed and in good condition.

2.7 OPERATIONAL SAFETY

The use of this equipment is subject to certain hazards that cannot be protected against by the mechanical means or product design. All operators of this equipment must read and understand this entire manual, paying particular attention to safety and operating instructions, prior to using. If there is something in this manual you do not understand, ask your supervisor, or your dealer, to explain it to you.

Most accidents occur because of neglect or carelessness. Keep all helpers and bystanders at least several hundred feet from an operating tiller. Only properly trained people should operate this machine. When machine is operated in populated areas where thrown objects could injure persons or property, **operation must be stopped when anyone comes within several hundred feet.**

The majority of accidents involve entanglement on the driveline, injury of bystanders by the objects thrown by the rotating tines, and operators being knocked off the tractor by low hanging limbs and then being run over by the tiller. Accidents are most likely to occur with machines that are loaned or rented to someone who has not read the owner's manual and is not familiar with a rotary tiller.

The rotary tiller is designed for use only on tractors with the power take-off (PTO) turning at 540 R.P.M.

Install and secure all guards and shields before starting or operating. The tiller tines, driveline guards and tractor shields should be used and maintained in good working condition. They should be inspected carefully, at least daily, for missing or broken chain links, shields, or guards. (Worn items must be replaced at once to reduce possibility of injury.)

Never place hands or feet under tiller with tractor engine running or before you are sure all motion has stopped. Stay clear of all moving parts. Do not reach or place any part of your body under equipment until it is blocked securely.

Do not allow riders on the tiller or tractor at any time. There is no safe place for any riders. Do not operate unless all personnel, livestock, and pets are several hundred feet away to prevent injury by thrown objects.

2.7 OPERATIONAL SAFETY (Continued)

Disengage Power Take-off (PTO) and place transmission in neutral before attempting to start engine.

Many varied objects, such as wire, cable, rope, or chains, can become entangled in the operating parts of the tiller. These items could then swing outside the housing at greater velocities than the tines. Such a situation is extremely hazardous. Inspect the cutting area for such objects before tilling. Remove any like objects from the site.

Never allow the tilling tines to contact such items. Never assume an area is clear. **Always Check!!**

Always stop the tractor, disengage PTO, set brake, shut off the tractor engine, remove the ignition key, lower implement to the ground and allow rotating pieces to come to a complete stop before dismounting tractor. Never leave equipment unattended with the tractor running.

Never operate tractor and rotary tiller under trees with low hanging limbs. Operators can be knocked off the tractor and then run over by the rotating tines.

The rotating parts of this machine have been designed and tested for rugged use. However, they could fail upon impact with heavy, solid objects such as steel guardrails and concrete abutment. Such impact could cause the broken objects to be thrown outward at very high velocities. To reduce the possibility of property damage, serious injury, or even death, never allow the tilling tines to contact such obstacles.

Stop rotary tiller and tractor immediately upon striking an obstruction. Turn engine off, remove key, inspect and repair any damage before resuming operation.

Stay alert for uneven terrain, holes, rocks, roots and other hidden hazards. Keep away from drop-offs and hazards that could cause roll over. Use extreme care and maintain minimum ground speed when transporting or operating on hill-sides, over rough ground and when operating close to ditches or fences. Be careful and slow down when turning sharp corners and changing direction on slopes. Do not start or stop suddenly on slopes. Avoid operation on steep slopes. In extremely uneven terrain, rear wheel weights, front tractor weight, and/or tire ballast should be used to improve stability.

Pass rotary tiller diagonally through sharp dips and avoid sharp drops to prevent "hanging up" tractor and rotary tiller. Practice will improve your skills in maneuvering on rough terrain. Always cut down slopes, never across the face. Always check tractor manual for proper use on slopes.

When using a unit, a minimum 20% of tractor and equipment weight must be on tractor front wheels. Without this weight, tractor could tip over, causing personal injury or death. The weight may be attained with a front end loader, front wheel weights, ballast in the tires or front tractor weights. When attaining a minimum 20% of tractor and equipment weight on the front wheels, you must not exceed the ROPS weight certification. Weight the tractor and equipment. **Do not guess or estimate!**

STARTING AND STOPPING SAFETY

Check the tractor master shield over the PTO stub shaft. Make sure it is in good condition and fastened securely to the tractor. Purchase a new shield if old shield is damaged or missing.

All tractors that are not equipped with a "live" Power Take-off (PTO) need to be equipped with an overrunning PTO clutch. These are available through most farm equipment stores.

NOTE: The addition of an overrunning PTO clutch may change the length of the PTO driveline required. Pay extra attention to the instructions on the PTO Driveline Installation. Be sure that the driveline system guarding is adequate.

Tiller operating power is supplied from the tractor PTO. Refer to your tractor manual for PTO engagement and disengagement instructions. Know how to stop tractor and tiller quickly in case of an emergency.

When engaging PTO, the engine RPM should always be at idle speed. Once engaged and ready to start tilling, raise PTO speed to 540 RPM and maintain throughout tilling operation.

2.8 TRANSPORT SAFETY

1. Comply with state and local laws governing highway safety and movement of farm machinery on public roads.
2. The use of flashing amber lights is acceptable in most localities. However, some localities prohibit their use. Local laws should be checked for all highway lighting and marking requirements.
3. At all times, when driving the tractor and equipment on the road or highway under 20 mph (32 kph) use flashing amber warning lights and a slow moving vehicle (SMV) identification emblem. Do not exceed 20 mph (32 kph). Reduce speed on rough roads and surfaces.
4. Plan your route to avoid heavy traffic.
5. Always install transport locks, pins, or brackets before transporting.
6. Do not drink and drive.
7. Be a safe and courteous driver. Always yield to oncoming traffic in all situations, including narrow bridges, intersections, etc. Watch for traffic when operating near or crossing roadways.
8. Turn curves or go up or down hills only at a low speed and at a gradual steering angle. Make certain that at least 20% of the tractor's weight is on the front wheels to maintain safe steering. Slow down on rough or uneven surface. Always check tractor manual for proper use on slopes.
9. Use extreme care and maintain minimum ground and when operating close to ditches or fences. Be careful when turning sharp corners.
10. Never allow riders on either tractor or mower.

2.9 STORAGE SAFETY

1. Following operation, or when unhooking the tiller, stop the tractor, set the brakes, disengage the PTO, shut off the engine and remove the ignition keys.
2. Store the unit in an area away from human activity.
3. Do not park equipment where it can be exposed to direct contact to livestock for long periods of time. Damage and livestock injury could result.
4. Make sure all parked machines are on a hard, level surface and engage all safety devices.

2.10 MAINTENANCE SAFETY

1. Good maintenance is your responsibility. Poor maintenance is an invitation to trouble.
2. Follow good shop practices.
 - Keep service area clean and dry.
 - Be sure electrical outlets and tools are properly grounded.
 - Use adequate light for the job at hand.
3. Make sure there is plenty of ventilation. Never operate the engine of the towing vehicle in a closed building. The exhaust fumes may cause asphyxiation.
4. Before working on this machine, disengage PTO, shut off the engine, set the brakes, and remove the ignition key. Be certain all moving parts on attachments have come to a complete stop before attempting to perform maintenance.
5. Never work under equipment unless it is blocked securely. Do not allow debris, grease or oil to build up on any deck or platform.
6. Use personal protection devices such as eye, hand, and hearing protectors, when performing any service or maintenance work.
7. Where replacement parts are necessary for periodic maintenance and servicing, genuine factory replacement parts **must** be used to restore your equipment to original specifications. The manufacturer will not be responsible for injuries or damages caused by use of unapproved parts and/or accessories.
8. A fire extinguisher and first aid kit should be kept readily accessible while performing maintenance on this equipment

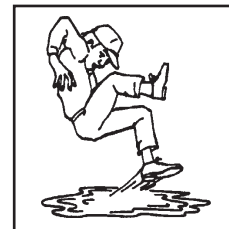

9. Frequently check tiller tines. They should be sharp, free of nicks and cracks and securely fastened. Periodically tighten all bolts, nuts and screws and check that all cotter pins are properly installed to ensure unit is in a safe condition.
10. When completing a maintenance or service function, be sure all tools, parts, and service equipment are removed from tiller, and make sure all safety shields and devices are installed before placing unit in service.

3 SET-UP & ASSEMBLY

3.1 ASSEMBLY INSTRUCTIONS

1. With rotary tiller still in crate, lay flat on a level surface. Cut banding straps on the two (2) up right crate posts.
2. Remove the top and upper side sections of the crate, leaving the rotary tiller resting on the bottom section. You may take the tiller off of the crate, but you must swing stand arm down and lock in position. (See *Figure D*) Snap stand out of clip, straighten out, then swivel the stand down to locked position.
3. Remove tie wire holding the PTO shaft and set aside PTO.
4. Attach tiller according to your tractors manual and using the instructions on **pages 12 through 14**.
5. Install tail back plate chain.
6. Install PTO shaft as outlined in the ***Attaching to Tractor Section, page 13***.

NOTE: *The safety chains on the PTO shaft should be attached to the tractor and tiller to prevent the plastic safety shield from rotating.*

3.2 BEFORE PUTTING ROTARY TILLER INTO SERVICE



(IMPORTANT - Instructions prior to start up)
SHIPPED WITH OIL IN GEAR BOXES
Shipped Without Grease in grease fittings.
Unit must be serviced before using.

- In gearboxes use gear oil (type GL5-85W 140 or Triple Zero Grease; which can be poured, and has "EP" i.e. "Extreme Pressure" additives.)
 - For all Grease Fittings use TYPE/grade II tube grease.
1. Place rotary tiller so that the deck is secure and level.
 2. Remove ½" pipe plug (located at top of transmission gearbox). (See *Figure A*).
 3. Check to see if gearbox is ½ full of oil, if not, fill gearbox using gear oil until gearbox is approximately ½ full. (See *Figure B*).
 4. Replace and tighten the ½" pipe plug and clean away any excess oil. (See *Figure C*).
 5. Remove ½" pipe plug (located at top of side gearbox, See *Figure E*) and the ⅛" check plug (located inside of the side gearbox) if oil comes out of check plug hole, replace plug immediately and go to number 7. If oil doesn't come out proceed to number 6.
 6. Fill side gearbox using gear oil until the oil begins to overflow from the check plug hole. (See *Figure F*).
 7. Replace and tighten the ½" vent plug and the ⅛" check plug. Clean away any excess oil. (See *Figure G*).
 8. Grease the grease fitting on the "outboard hub", the two (2) grease fittings on the PTO universal joints, the two (2) grease fittings on the PTO safety shield and the inner surface portion of the PTO shaft. (See *Figures H, I and J*).

3.2 BEFORE PUTTING ROTARY TILLER INTO SERVICE (Continued)



CAUTION: DO NOT overfill gearbox. This could cause damage to oil seals and can cause permanent damage to the gearbox. This issue will not be covered under warranty.



Figure A

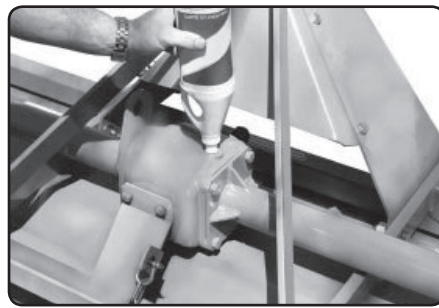

Figure B



Figure C

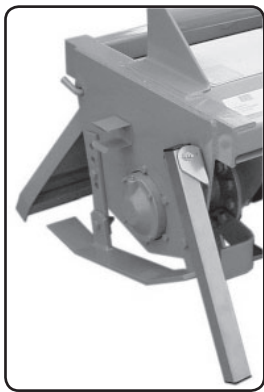

Figure D



Figure E

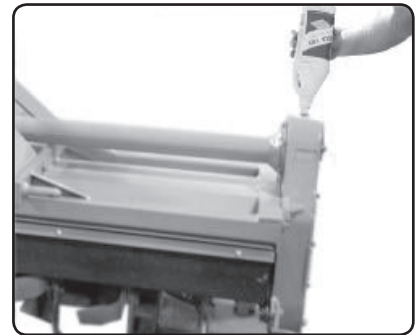

Figure F

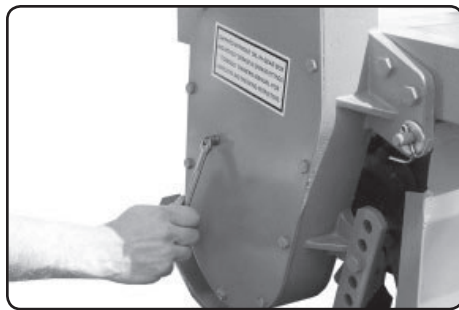

Figure G

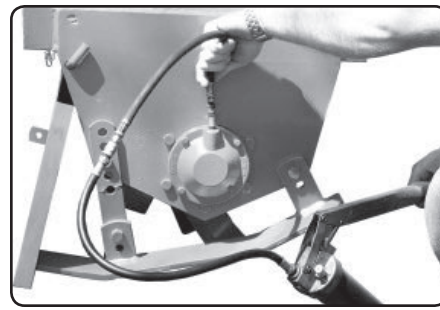

Figure H

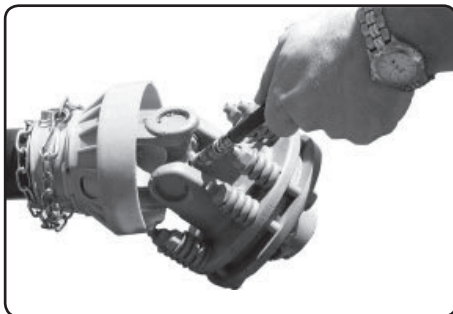

Figure I

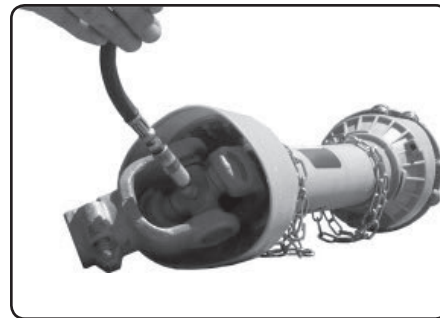

Figure J

3.3 ATTACHING TO TRACTOR



WARNING: NEVER stand between tractor and rotary tiller while backing up tractor to the hitch.

1. Attach to tractor's category 1, 3-point hitch as described in the *Tractor's Operator's Manual*.

2. Determine if the PTO shaft needs to be shortened.

NOTE: Due to the many variations in the tractor hitch points and distances between equipment gearbox input shaft and tractor PTO output shafts, some combinations may require PTO shafts to be shortened as described by the following steps.

3. Raise and lower rotary tiller in order to locate the shortest distance between equipment gearbox input shaft and tractor PTO output shaft. With the rotary tiller in the shortest distance position, shut down the tractor and **SECURELY BLOCK ROTARY TILLER IN POSITION**.

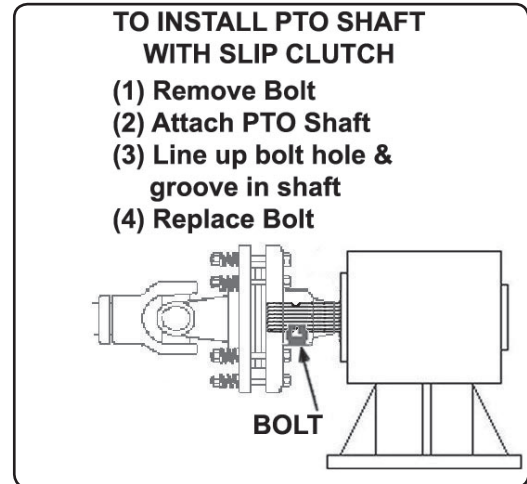

WARNING: IF THE TILLER IS RAISED UP SO THAT THE PTO SHAFT IS AT AN ANGLE SHARPER THAN 35 DEGREES, PTO MUST BE STOPPED!

4. Pull apart PTO shaft and attach outer section to tractor PTO output shaft.

NOTE: Be sure to pull on PTO shaft section to ensure yoke has locked into place.

5. Place and hold inner PTO shaft section next to outer section and check if PTO shaft is too long. Each section should end approximately 3 inches short of reaching u-joint shield on the opposite section. If the shaft is too long, measure 3 inches back from each u-joint shield and mark the other shaft section. Be sure to do this for both PTO shaft halves. **NOTE:** Do not cut PTO shaft sections at this time.
6. Raise rotary tiller and remove blocking. Raise and lower rotary tiller in order to locate the longest distance between equipment input shaft and the tractor PTO output shaft. With the rotary tiller in the longest distance position shut down the tractor and **SECURELY BLOCK THE ROTARY TILLER IN POSITION**.
7. As in step 5, hold PTO shaft sections together and check for a minimum of 6 inches of overlap. If PTO shaft has been marked for cutting the overlap is the distance measured between the two marks. If the PTO shaft has less than a 6 inch overlap, **DO NOT USE**. Contact your authorized Gearmore Dealer.

NOTE: If the PTO shaft length is too long go to *Sizing PTO Shaft Page 14*.

8. Apply any multi-purpose grease to the outside of the male (inner) PTO shaft section. Assemble PTO shaft and install on rotary tiller and tractor.
9. Pull on tractor side of PTO shaft yoke to be sure it has locked in place. Make certain PTO shaft shielding is in place and in good working condition.
10. The PTO shaft shield is a non-rotating design and must be secured prior to equipment use. Using the chain on each yoke shield attach to a fixed object on the tractor and equipment ends that will not allow the PTO shaft shield to rotate during operation.

3.4 SIZING PTO SHAFT

1. Cutting the PTO shaft to length.

NOTE: Be sure to cut equal lengths of each PTO shaft section. Clamp end of PTO shaft in a vice and cut off shield where marked. (*Figure 1-A and 1-B*).

2. Using cut section of the shield as a guide cut shaft off the same amount. (*Figure 2*)

3. Repeat steps 1 and 2 for other PTO shaft section.

4. Use a file to deburr PTO shafts. Clean up all chips, burrs, and filings from both ends of the PTO shaft.

NOTE: If you shear the bolt that attaches the PTO shaft to the gearbox replace with a grade 2 bolt only. Replacement with another grade of bolt will void your warranty and may cause terminal damage to the PTO shaft, gearbox, or tractor.



Figure 1-A



Figure 1-B



Figure 2

4 OPERATING INSTRUCTIONS

1. Before each use, perform the maintenance as described in the *Maintenance Section (Page 16)*.
2. Read, understand, and follow the information on safety training, preparation, starting and stopping safety, operational safety, and transport safety warning sections of this manual.
3. With the rotary tiller positioned on level ground, adjust the tractor lift arms so that when lifted, the rotor bar remains parallel to the ground.
4. With the rotary tiller attached to the tractor, raise and support the tiller with suitable blocks. Adjust the skids, located on the sides of the tiller. The adjustment bolts for both right and left sides should be positioned in the same adjustment hole. This allows the tiller to till the same depth on each side. Adjust the back plate, with regulating chain, until the desired mulching effect is found.

NOTE: *Never attempt to adjust the rotary tiller while the tractor is running.*

5. Raise the tiller and remove the blocks. Lower the tiller to the ground.
6. With the tractor at idle RPM and the tiller lifted off of the ground, engage PTO and slowly advance throttle to 540 PTO R.P.M.

NOTE: *Rotary tiller is designed to run at 540 PTO R.P.M. only.*

7. Select a low gear for the tractor and begin to move forward. Tractor ground speed is to be controlled by gear selection only and not engine speed. As the tractor moves forward, slowly lower the tiller down. Allow the tiller tines to gradually engage the ground.



NOTE: *Do not allow the tractor engine or rotary tiller to bog down or stall. This causes undue wear and tear on the tiller and tractor. If this continues to happen, reduce ground speed and raise tilling depth of rotary tiller. Never attempt to remove objects from the rotor bar until the tractor has been shut down and the tiller tines have completely stopped.*



WARNING: *Never travel at a fast ground speed while using the tiller, this could damage it. Never attempt to turn the tractor or travel in reverse with the PTO engaged and the tiller in the ground. Always raise the tiller out of the ground when backing up or attempting to turn. Failure to do so may cause damage to the tiller.*

8. After each use, clean all debris from the tiller tines. Replace any missing or illegible safety decals. Inspect for any damaged or worn parts and replace before next use. Store rotary tiller in a dry, safe environment away from human activity.

4.1 END OF SEASON

Thoroughly clean the entire tiller.

Remove any foreign material from around all tines.

Clean off any dirt or material build up around the PTO and gearbox.

Check machine for any damage, loose or missing bolts and fasteners, broken or missing flails etc.

Fix anything found prior to operating the machine again.

Lubricate the machine completely regardless of schedule.

Check gearbox oil and fill to recommended level.

Paint any parts that have missing paint (this will greatly reduce rust build up during the off season).

Unhook the PTO and store it inside, clean it and grease it, spray both spline ends liberally with a silicone based lubricant.

Put a light coating of grease on the splines of the input shaft on the gearbox.

Store the machine inside if possible.

5 MAINTENANCE

The following is a list of general things to watch for while operating this Tiller. Replace or repair anything you may find damaged before operating machine.

- Check machine daily for any visible damage. Do a thorough walk around before running the machine for the day. If any damage is evident fix or replace as needed before operating machine.
- Periodically check and maintain proper gear oil level.
- Every 8 hours:
 1. Grease "out-board hub"
 2. PTO shaft universal joints
 3. PTO shaft safety shield
 4. PTO telescoping surface

NOTE: Use only a grade Type II tube grease

NOTE: Do not grease the slip clutch assembly

- Check all bolts and fasteners daily, tighten or replace as needed. It is particularly important to check bolts and fasteners over the first 24 hours of operation.
- Clean the machine often, keep material off of the gearbox and PTO. Keep areas around bearings as clean as possible.
- Before each use check to make sure all safety shields are installed and working properly.
- Check tiller tines for cracks and breaks before every use. Replace if necessary.
- Periodically loosen torque spring bolts and allow slip clutch to slip for approximately two (2) revolutions. Loosen the bolts until the springs lose contact with the flange yoke. This ensures that the slip clutch is not in a "locked" position.
- Make sure that the clutch slips.
- To re-tighten the slip clutch, tighten the torque spring bolts until the nut makes contact with the flange yoke and further tighten one and a half turns (1-1/2). This is a good starting point, further adjustments may need to be made based on soil conditions.

NOTE: Do not over or under tighten slip clutch assembly or damage may occur.

- Replace any missing shields and warning decals.

6 SPECIFICATIONS

MODEL:	E48	E60	E72	E84
Tilling Width:	48"	60"	72"	84"
Overall Width:	53"	65"	77"	89"
Number of Tines:	36	42	54	66
No. of Tines Per Flange:	6	6	6	6
Approx. Horsepower:	20 to 35 HP	25 to 40 HP	35 to 50 HP	50 to 65 HP
3-Point Hitch:	Cat. 1, 540 RPM	Cat. 1, 540 RPM	Cat. 1, RPM	Cat. 1 & 2, 540 RPM
Driveshaft:	Slip Clutch	Slip Clutch	Slip Clutch	Slip Clutch
Weight:	600 lbs.	690 lbs.	780 lbs.	805 lbs.

7 PARTS

7.1 ORDERING PARTS

To order a part, you can call your local Gearmore dealer. Please have the model number, serial number and quantity of each item.

Make sure to inspect the parts at time of receipt and immediately call your dealer if any damage is evident. Damaged parts will only be accepted for refund if we are notified at the time of receipt of shipment.

7.2 TILLER

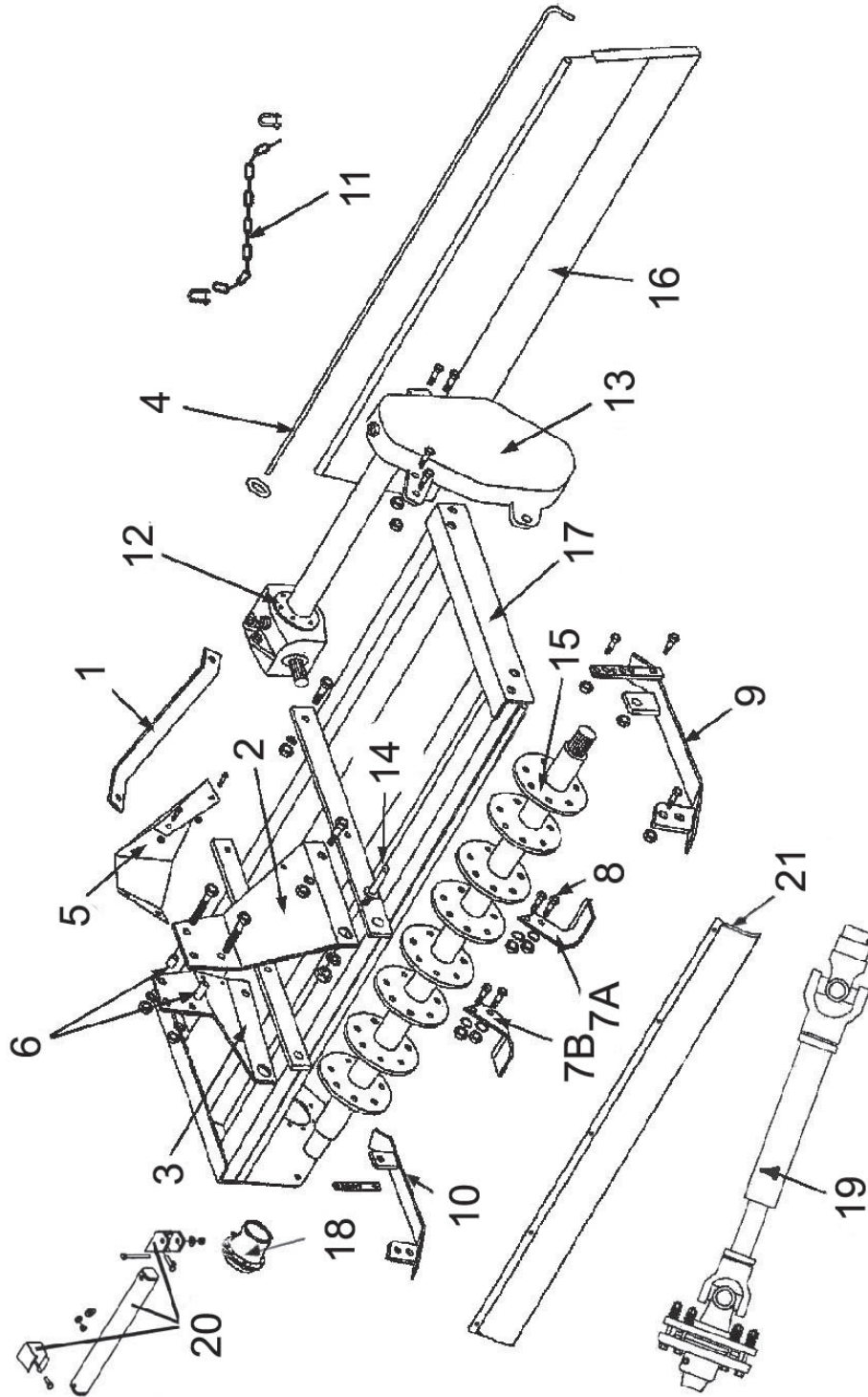

7.2 TILLER (Continued)

<u>REF #</u>	<u>PART NO.</u>	<u>DESCRIPTION</u>
1	380108	Lift Arm Brace
2	310085	Lift Arm (Left Hand)
3	310086	Lift Arm (Right Hand)
4	505116	Tail Rod Assembly E48
4	505016	Tail Rod Assembly E60
4	505014	Tail Rod Assembly E72
4	505015	Tail Rod Assembly E84
5	505025	Center Piece Kit
6	505030	Lift Arm spacer Kit
7A	173007	Tine L.H.
7B	173008	Tine R.H.
		E48 - (36 Tines)
		E60 - (42 Tines)
		E72 - (54 Tines)
		E84 - (66 Tines)
8	505012	Tine Bolt Pkg. (12 Bolts)
8	505072	Tine Bolt Pkg. (72 Bolts)
8	505084	Tine Bolt Pkg. (84 Bolts)
8	505108	Tine Bolt Pkg. (108 Bolts)
8	505132	Tine Bolt Pkg. (132 Bolts)
9	505050	Skid Assembly (Left Hand)
10	505057	Skid Assembly (Right Hand)
11	505143	Chain & shackle Kit
12	184064	Top Gearbox Assembly E48
12	184066	Top Gearbox Assembly E60
12	184067	Top Gearbox Assembly E72
12	184068	Top Gearbox Assembly E84
13	184069	Side Gearbox Assembly
14	500001	Lift Pins (Cat. 1, Pkg of 2) E48, E60 & E72
14	500003	Straight Lift Pins (Cat. 1 to 2, Pkg of 2) E84
15	402038	Rotor Assembly E48
15	402042	Rotor Assembly E60
15	402053	Rotor Assembly E72
15	402064	Rotor Assembly E84
16	402041	Back Plate Assembly E48
16	402046	Back Plate Assembly E60
16	402052	Back Plate Assembly E72
16	402067	Back Plate Assembly E84
17	402039	Frame Assembly E48
17	402043	Frame Assembly E60
17	402054	Frame Assembly E72
17	402068	Frame Assembly E84
18	184070	Outboard Hub Assembly
19	147122	PTO Shaft E48, E60 & E72
19	147129	PTO Shaft E84
20	505022	Support Stand Assembly
21	380233	Top Gearbox Support E84
22	194111	Top Link Pin Cat. 1 to 2 (E84 only)

7.3 PTO 147122

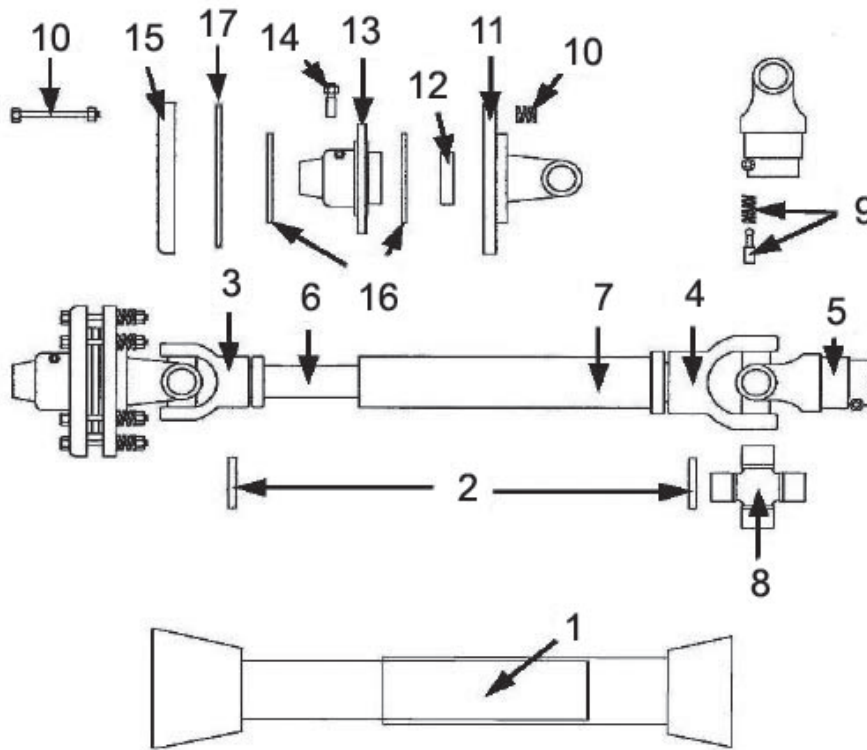

<u>REF #</u>	<u>PART NO.</u>	<u>DESCRIPTION</u>
1	124311	Safety Shield
2	170120	Roll Pin
3	151045	Male Tube End Yoke
4	151050	Female Tube End Yoke
5	151035	Tractor End Yoke
6	151090	Inner Tube 14 Series
7	151091	Outer Tube 14 Series
8	170015	Cross Kit #4
9	170110	Quick Disconnect Pin
10	500150	Clutch Spring w/Compression Bolts & Nuts (Pkg. 8)
11	140226	Flanged Yoke
12	140221	Bushing
13	140220	Friction Hub
14	140224	10 x 70 Bolt
15	140216	Pressure Plate (Outer)
16	140219	Friction Disc for 6" Slip Clutch (4 3/4" OD x 2 1/16" ID)
16	196008	Friction Disc for 7" Slip Clutch(5 1/2" OD x 3 5/16" ID)
17	124317	Inner Disc

7.4 OUTBOARD HUB 184070

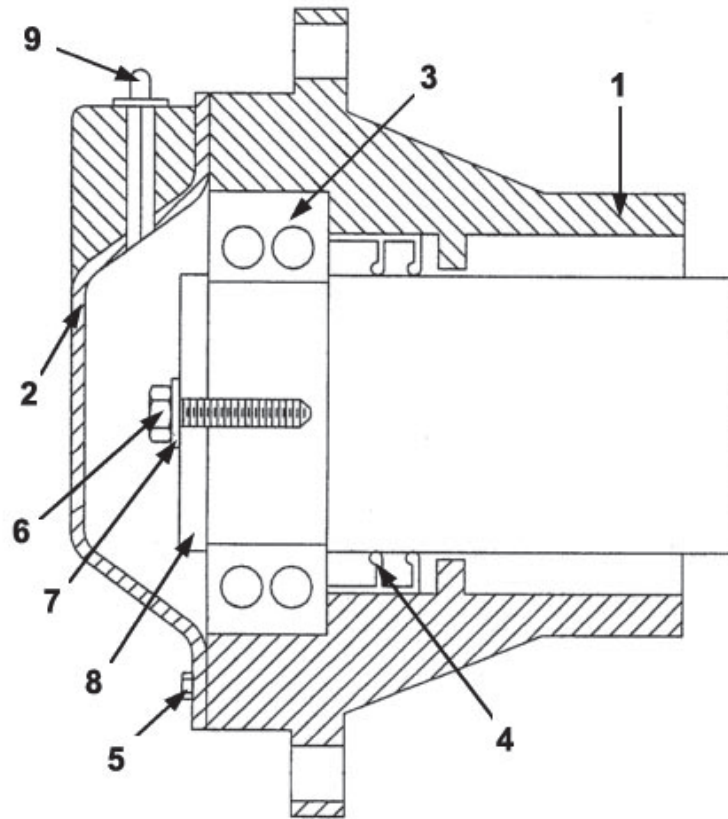

<u>REF #</u>	<u>PART NO.</u>	<u>DESCRIPTION</u>
1	902341	Hub Housing
2	902342	Cap
3	902019	Self Aligning Ball Bearing (1310)
4	505017	Seal Double Lip (Pkg. 2)
5	902345	Bolt M-6 -16
6	902011	Bolt M-12 - 25
7	902010	Lock Washer M-12
8	902009	Washer
9	902349	Grease Zerk ¼"

7.5 GEARBOX 184069

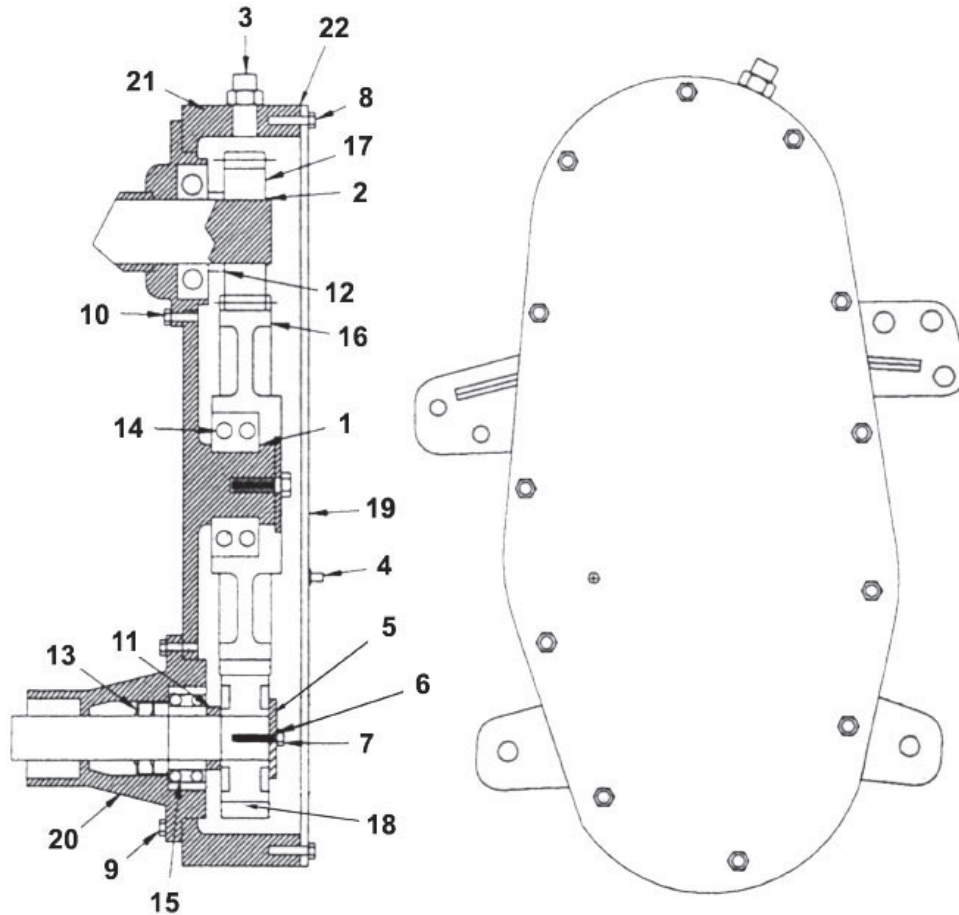

<u>REF #</u>	<u>PART NO.</u>	<u>DESCRIPTION</u>
1	902005	Retaining Ring 90mm
2	902006	Retaining Ring 40mm
3	902007	Pressure Plate Plug ½" - 14 NPT
4	902008	Square Head Plug ¼" - 18 NPT
5	902009	Flat Washer (Main)
6	902010	Lock Washer M-12
7	902011	Bolt M-12-25
8	502247	Bolt M-8-16 (Pkg. 12)
9	502296	Bolt M-10-25 (Pkg. 6)
10	502207	Bolt M-10-20 (Pkg. 6)
11	902015	Spacer (Output)
12	902016	Spacer (Input)
13	505017	Seal Double Lip (Pkg. 2)
14	902018	3210 Double Bearing (Ball)
15	902019	1310 Self Aligning Bearing (Ball)
16	902021	Gear - 34 Teeth
17	902022	Gear - 16 Teeth
18	902020	Gear - 28 Teeth
19	902001	Cover
20	902002	Side Box Outboard Hub Housing
21	902003	Housing
22	902004	Gasket

7.6 TOP GEARBOX ASSEMBLY

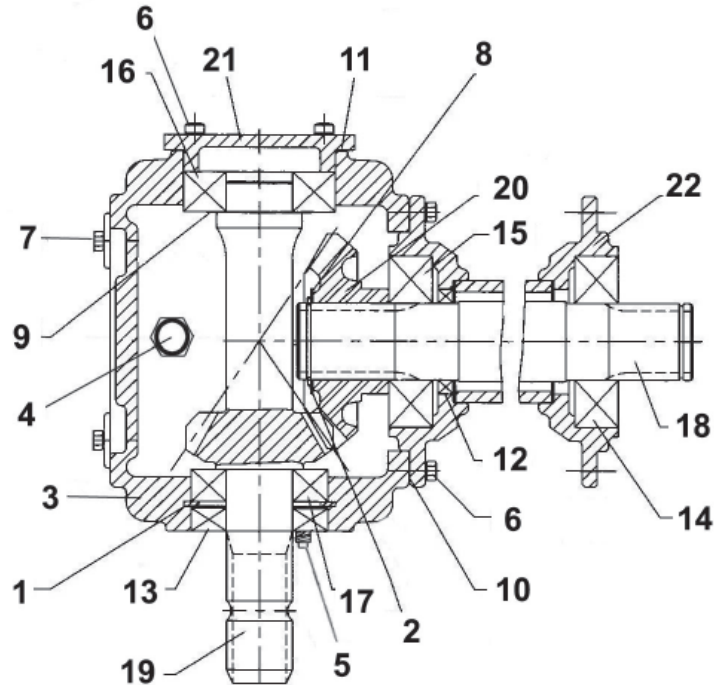

<u>REF #</u>	<u>PART NO.</u>	<u>DESCRIPTION</u>
1	902301	Retaining Ring 72mm
2	902302	Retaining Ring 40mm
3	902329	Housing RTA - 50
4	902304	Pressure Plate Plug 1/2" - 14 NPT
5	902305	Square Head Plug 1/4" - 18 NPT
6	502296	Bolt M-10-25 (Pkg. 6)
7	505008	Bolt M-10-30 (Pkg. 4)
8	902309	Spacer
9	502243	Shim Pack (Pkg. 8)
10	902314	Output Gasket 0.8mm
10	902315	Output Gasket 0.5mm
11	902316	Input Gasket 0.4mm
11	902317	Input Gasket 0.2mm
12	902318	Output Seal Double Lip
13	902319	Input Seal Double Lip
14	902320	Sealed Ball Bearing (6308)
15	902321	Ball Bearing (6308)
16	902322	Ball Bearing (6307)
17	902323	Ball Bearing (6207)
18	902324	Output Shaft E48 500mm
18	902330	Output Shaft E60 700mm
18	902331	Output Shaft E72 900mm
18	902336	Output Shaft E84
19	902325	Pinion Shaft 13 Teeth
20	902326	Output Gear 19 Teeth
21	902327	Cap Blank
22	902328	Cap Hub E48 500mm
22	902332	Cap Hub E60 700mm
22	902333	Cap Hub E72 900mm
22	902337	Cap Hub E84

8 LIMITED WARRANTY

The Manufacturer warrants to the original retail purchaser ("Purchaser") that the product that is the subject of this sale is free from defects in material and workmanship at the time of sale.

Under this warranty, the manufacturer will repair the defective product free of charge to the Purchaser, with either new or used and reconditioned replacement parts. All warranty service will be performed at service centers designated by the manufacturer. If the service center is unable to repair the product to conform to the warranty after a reasonable number of attempts, the manufacturer will provide, at its option, one of the following: (a) a replacement for the product or, (b) a full refund of the purchase price. Repair, replacement, or refunds are the Purchaser's EXCLUSIVE remedies against the manufacturer under this limited warranty. The manufacturer will not be liable for any special, incidental or consequential damages based upon breach of warranty, breach of contract, negligence, strict tort liability, or any other legal theory. Such damages include, but are not limited to, loss of profits, loss of savings or revenue, loss of use of the product or any associated equipment, cost of capital, cost of any substitute equipment, facilities or services, down time, the claims of third parties including customers, and injury to property. These limitations also apply, to the extent allowed by law, to personal injury.

The purchaser must notify the Seller in writing of any defect in material or workmanship within one (1) year following the date of purchase. If the equipment is used for commercial purposes, the Purchaser must notify the Seller in writing of any defect in material or workmanship within ninety (90) days following the date of purchase. In no event will the manufacturer be liable under this warranty unless written notice is received by the Seller within one (1) year from the date of original retail sale.

WARRANTY OF TITLE

The manufacturer warrants that it transfers a good title to the product free of any encumbrances, and free of the rightful claim of any third party for infringement of patent or copyright.

WHAT IS NOT COVERED BY THIS LIMITED WARRANTY

The manufacturer will not be responsible for damage to or failure in the product which results from accident, misuse, abuse, neglect, installation of attachments not provided by the manufacturer, modifications to the product, or damage caused by use of the product for purposes other than those for which it was designed.

NO OTHER WARRANTIES

Unless modified in writing and signed by both parties, this agreement is understood to be the complete and exclusive agreement and warranty between the manufacture and Purchaser, superseding all prior agreements, oral and written, and all other communication between the manufacturer and Purchaser related to the subject matter of this agreement.

THIS LIMITED WARRANTY IS IN LIEU OF ALL OTHER WARRANTIES, EXPRESS OR IMPLIED, INCLUDING, BUT NOT LIMITED TO, THE IMPLIED WARRANTY OF MERCHANTABILITY AND THE IMPLIED WARRANTY OF FITNESS FOR A PARTICULAR PURPOSE. No employee of the manufacturer nor anyone else is authorized to make any warranty or representation in addition to or different from those made in this agreement.

ALLOCATION OF RISK

This agreement allocates the risk of product failure between the manufacturer and the Purchaser. This Allocation is recognized by both parties as reflected in the price of the goods. The Purchase acknowledges that he or she has read this agreement, understands it, and is bound by its terms.