



COMPACT DRAG SCRAPERS

**Operation, Service,
& Parts Manual
For CD Series Drag Scrapers**

December 2016

TABLE OF CONTENTS

<u>SECTION</u>	<u>DESCRIPTION</u>	<u>PAGE</u>
1	Introduction	1
1.1	Purchaser's Responsibility	1
2	Safety	2 - 8
2.1	General Safety	3
2.2	Equipment Safety Guidelines	4
2.3	Safety Training	5
2.4	Safety Signs	5
2.5	Preparation	6
2.6	Operational Safety	7
2.7	Transport Safety	8
2.8	Storage Safety	8
2.9	Maintenance Safety	8
3	Assembly & Operation	9
3.1	Attaching Unit	9
4	Service & Maintenance	10
4.1	Servicing Instructions	10
4.2	Cutting Edge Replacement	10
4.3	Bolts & Torque Specifications	10
5	Replacement Parts	11
6	Limited Warranty	12

1 INTRODUCTION

This manual contains valuable information about your new Gearmore Compact Drag Scraper. It has been carefully prepared to give you helpful suggestions for operating, adjusting, servicing and ordering repair parts.

Keep this manual in a convenient place for quick and easy reference. Study it carefully. You have purchased a dependable and sturdy drag scraper, but only by proper care and operation can you expect to receive the service and long life designed and built into it.

Sometime in the future your drag scraper may need new parts to replace those that are worn or broken. If so, go to your dealer and provide him with the model and part number.

OPERATOR ORIENTATION - The directions left, right, front and rear, as mentioned throughout this manual, are as seen from the driver's seat and facing in the direction of travel.

1.1 PURCHASER'S RESPONSIBILITY

It is the responsibility of the purchaser and/or operator to.....

- Read and understand the information contained in this manual.
- Operate, lubricate, assemble and maintain the equipment in accordance with all instructions and safety procedures in this manual.
- Inspect the equipment and replace or repair any parts that are damaged or worn which under continued operation would cause damage, wear to other parts, or cause a safety hazard.
- Return the equipment or parts to the authorized dealer, from where it was purchased, for service or replacement of defective parts that are covered by warranty. (The factory may inspect equipment or parts before warranty claims are honored.)
- Payment of all costs incurred by the dealer for traveling to or transporting the equipment for warranty inspection and or claims.

NAME: _____

PURCHASED FROM: _____

DATE OF PURCHASE: _____

MODEL NUMBER: _____

SERIAL NUMBER: _____

2 SAFETY

SAFETY ALERT SYMBOL

This Safety Alert symbol means **ATTENTION! BECOME ALERT! YOUR SAFETY IS INVOLVED!**

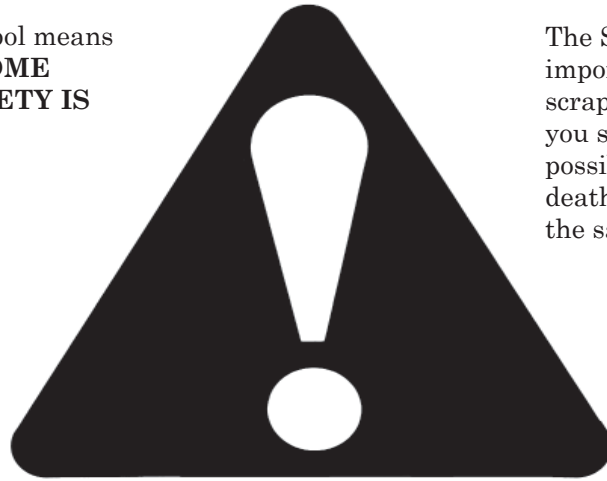

The Safety Alert symbol identifies important safety messages on the scraper and in the manual. When you see this symbol, be alert to the possibility of personal injury or death. Follow the instructions in the safety message.

Why is SAFETY important to you?

3 Big Reasons

Accidents Disable and Kill
Accidents Cost
Accidents Can Be Avoided

SIGNAL WORDS:

Note the use of the signal words **DANGER**, **WARNING** and **CAUTION** with the safety messages. The appropriate signal word for each message has been selected using the following guide-lines:

SI NO LEE INGLES, PIDA AYUDA A AIGUIEN QUE SI LO LEA PARA QUE LE TRADUZCA LAS MIDIDAS DE SEGURIDAD.

DANGER - Indicates an imminently hazardous situation that, if not avoided, will result in death or serious injury. This signal word is to be limited to the most extreme situations typically for machine components which, for functional purposes, cannot be guarded.

WARNING - Indicates a potentially hazardous situation that, if not avoided, could result in death or serious injury, and includes hazards that are exposed when guards are removed. It may also be used to alert against unsafe practices.

CAUTION - Indicates a potentially hazardous situation that, if not avoided, may result in minor or moderate injury. It may also be used to alert against unsafe practices.

If you have any questions not answered in this manual or require additional copies or the manual is damaged, please contact your dealer.

2.1 GENERAL SAFETY

YOU are responsible for the **SAFE** operation and maintenance of your scraper. **YOU** must ensure that you and anyone else who is going to operate, maintain or work around the scraper be familiar with the operating and maintenance procedures and related **SAFETY** information contained in this manual. This manual will take you step-by-step through your working day and alerts you to all good safety practices that should be adhered to while operating the scraper.

Remember, **YOU** are the key to safety. Good safety practices not only protect you, but also the people around you. Make these practices a working part of your safety program. Be certain that **EVERYONE** operating this equipment is familiar with the recommended operating and maintenance procedures and follows all the safety precautions. Most accidents can be prevented. Do not risk injury or death by ignoring good safety practices.

- Scraper owners must give operating instructions to operators or employees before allowing them to operate the machine, and at least annually there after per OSHA (Occupational Safety and Health Administration) regulation 1928.57.
- The most important safety feature on this equipment is a **SAFE** operator. It is the operator's responsibility to read and understand **ALL** Safety and Operating instructions in the manual and to follow these. Most accidents can be avoided.
- A person who has not read and understood all operating and safety instructions is not qualified to operate the machine. An untrained operator exposes himself and bystanders to possible serious injury or death.
- **DO NOT** modify the equipment in any way. Unauthorized modification may impair the function and/or safety and could affect the life of the equipment.
- **Think SAFETY! Work SAFELY!**

1. Read and understand the Operator's Manual and all safety signs before operating, maintaining, or adjusting the scraper.



2. Have a first-aid kit available for use should the need arise and know how to use it.



3. Have a fire extinguisher available for use should the need arise and know how to use it.



4. Wear appropriate protective gear. This list includes but is not limited to:

- A hard hat
- Protective shoes with slip resistant soles
- Protective goggles, glasses or face shield
- Heavy gloves
- Protective clothing - always wear relatively tight and belted clothing to avoid entanglement in moving parts.

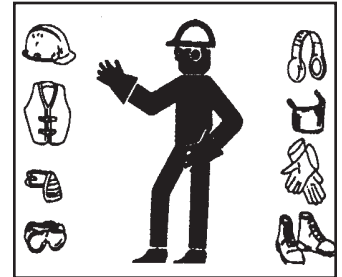

5. Install and secure all guards before starting.



6. **DO NOT** allow riders.

7. Wear suitable ear protection for prolonged exposure to excessive noise.

8. Place all controls in neutral, stop tractor engine, set park brake, remove ignition key and wait for all moving parts to stop before servicing, adjusting, repairing, or unplugging.

9. Clear the area of people, especially small children, before starting.

10. Review safety related items annually with all personnel who will be operating or maintaining the scraper.

2.2 EQUIPMENT SAFETY GUIDELINES

Safety of the operator and bystanders is one of the main concerns in designing and developing a drag scraper. However, every year many accidents occur which could have been avoided by a few seconds of thought and a more careful approach to handling equipment. You, the operator, can avoid many accidents by observing the following precautions in this section. To avoid personal injury or death, study the following precautions and insist those working with you, or for you, follow them.

- In order to provide a better view, certain photographs or illustrations in this manual may show an assembly with a safety shield removed. However, equipment should **never** be operated in this condition. Keep all shields in place. If shield removal becomes necessary for repairs, replace the shield prior to use.
- Replace any safety sign or instruction sign that is not readable or is missing.
- **NEVER** use alcoholic beverages or drugs which can hinder alertness or coordination while operating this equipment. Consult your doctor about operating this machine while taking prescription medications.
- **Under no circumstances should young children be allowed to work with this equipment. Do not allow persons to operate or assemble this unit until they have read this manual and have developed a thorough understanding of the safety precautions and of how it works. Review the safety instructions with all users annually.**

- This equipment is dangerous to children and persons unfamiliar with its operation. The operator should be a responsible, properly trained and physically able person familiar with farm machinery and trained in this equipment's operations. If the elderly are assisting with farm work, their physical limitations need to be recognized and accommodated.
- Use a tractor equipped with a Roll Over Protective Structure (ROPS) and always wear a seat belt.
- **NEVER** exceed the limits of a piece of machinery. If its ability to do a job, or to do so safely, is in question - **DON'T TRY IT.**
- Do not modify the equipment in any way. Unauthorized modification may impair the function and/or safety and could affect the life of the equipment.

In addition to the design and configuration of this implement, including Safety Signs and Safety Equipment, hazard control and accident prevention are dependent upon the awareness, concern, prudence and proper training of personnel involved in the operation, transport, maintenance and storage of the machine. Refer also to Safety Messages and operation instruction in each of the appropriate sections of the tractor and machine manuals. Pay close attention to the Safety Signs affixed to the tractor and the drag scraper.

Don't hurry the learning process or take the unit for granted. Ease into it and become familiar with your new equipment. Practice operation of your equipment and its attachments. Completely familiarize yourself and other operators with its operations before using.

Think SAFETY! Work SAFELY!

! WARNING



Before operating your machine, stop and read this owners manual. Do not attempt to operate the unit until you fully understand the material covered in this manual. Without the knowledge contained in this manual, injury or death can result.

2.3 SAFETY TRAINING

Safety is a primary concern in the design and manufacture of our products. Unfortunately, our efforts to provide safe equipment can be wiped out by a single careless act of an operator or bystander.

In addition to the design and configuration of equipment, hazard control and accident prevention are dependent upon the awareness, concern, prudence and proper training of personnel involved in the operation, transport, maintenance and storage of this equipment.

It has been said, "***The best safety feature is an informed, careful operator.***" We ask you to be that kind of an operator. It is the operator's responsibility to read and understand ALL Safety and Operating instructions in the manual and to follow these. Accidents can be avoided.



Working with unfamiliar equipment can lead to careless injuries. Read this manual, and the manual for your tractor, before assembly or operating, to acquaint yourself with the machines. If this machine is used by any person other than yourself, or is loaned or rented, it is the machine owner's responsibility to make certain that the operator, prior to operating:

- a. Reads and understands the operator's manuals.
- b. Is instructed in safe and proper use.

Should ownership of the equipment be transferred, this manual must also be transferred.

Know your controls and how to stop tractor, engine and machine quickly in an emergency. Read this manual and the one provided with your tractor.

Train all new personnel and review instructions frequently with existing workers. Be certain only a properly trained and physically able person will operate the machinery. A person who has not read and understood all operating and safety instructions is not qualified to operate the machine. An untrained operator exposes himself and bystanders to possible serious injury or death. If the elderly are assisting with farm work, their physical limitations need to be recognized and accommodated.

For any part of this manual that you do not understand, contact your dealer or Gearmore, Inc.

2.4 SAFETY SIGNS

1. Safety decals and this manual must be considered a permanent part of your equipment.
2. Keep safety signs clean and legible at all times.
3. Replace safety signs that are missing or have become illegible.
4. Replaced parts that displayed a safety sign should also display the current sign.
5. Safety signs are available from your authorized dealer or from Gearmore.

How To Install Safety Signs:

- Be sure that the installation area is clean and dry.
- Be sure temperature is above 50° F (10° C).
- Determine exact position before you remove the backing paper.
- Remove the smallest portion of the split backing paper.
- Align the sign over the specified area and carefully press the small portion with the exposed sticky backing in place.
- Slowly peel back the remaining paper and carefully smooth the remaining portion of the sign in place.
- Small air pockets can be pierced with a pin and smoothed out using the piece of sign backing paper.

2.5 PREPARATION

1. Never operate the tractor and machine until you have read and completely understand this manual, the Tractor Operator's Manual and each of the Safety Messages found on the safety signs on the tractor and scraper.

2. Personal protection equipment, including hard hat, safety glasses, safety shoes and gloves are recommended during assembly, installation, operation, adjustment, maintaining, repairing, removal or moving the implement. **DO NOT** allow long hair, loose fitting clothing or jewelry to be around equipment.

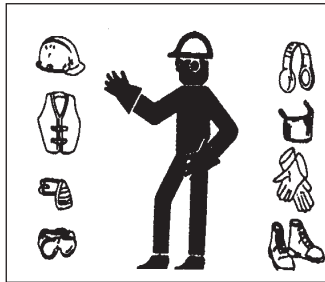

3. **PROLONGED EXPOSURE TO LOUD NOISE MAY CAUSE PERMANENT HEARING LOSS!**

Tractors with or without equipment attached can often be noisy enough to cause permanent, partial hearing loss. We recommend that you wear hearing protection on a full-time basis if the noise in the Operator's position exceeds 80db. Noise over 85db on a long-term basis can cause severe hearing loss. Noise over 90db adjacent to the Operator over a long-term basis may cause permanent, total hearing loss.



NOTE: Hearing loss from loud noise (from tractors, chain saws, radios, and other such sources close to the ear) is cumulative over a lifetime without hope of natural recovery.

4. Operate the scraper only with a tractor equipped with an approved Roll-Over Protective Structure (ROPS). Always wear your seat belt. Serious injury or even death could result from falling off the tractor --- particularly during a turn-over when the operator could be pinned under the ROPS or the tractor.



5. The operator may come in contact with certain materials, which may require specific safety equipment, relative to the handling of such materials.
6. Clear the area of debris. Be sure there are no tools lying on or in the equipment. Do not use until you are sure that the area is clear, especially of children and animals.
7. Give the unit a visual inspection for any loose bolts, worn parts or cracked welds, and make necessary repairs. Follow the maintenance safety instructions included in this manual.
8. Keep wheel lug nuts or bolts tightened to specific torque. Assure that agricultural implement tires are evenly inflated.
9. Because it is possible that this equipment may be used in dry areas or in the presence of combustibles, special precautions should be taken to prevent fires and fire-fighting equipment should be readily available.
10. **Never** permit any person, other than the operator, to ride on board the tractor at any time.
11. **DO NOT** allow riders on implement at any time. Operate only in daylight or good artificial light. **ALWAYS** wear relatively tight and belted clothing when operating implement. Loose clothing should not be worn, as it could get caught in the moving parts or controls.
12. A minimum of 20% of the tractor and equipment weight must be on the tractors front wheels with the box scraper in transport position. Without this weight, the tractor could tip over causing personal injury or death. The weight may be attained with front wheel weights, ballast in tires or front tractor weights. When attaining the minimum 20% weight on the front wheels, you must not exceed the Roll Over Protection Structure (ROPS) weight certification. Weigh tractor and equipment. Do not guess or estimate.

2.6 OPERATIONAL SAFETY

The use of this equipment is subject to certain hazards that cannot be protected against by the mechanical means or product design. All operators of this equipment must read and understand this entire manual, paying particular attention to safety and operating instructions, prior to using. If there is something in this manual you do not understand, ask your supervisor, or your dealer, to explain it to you.

Most accidents occur because of neglect or carelessness. Keep all helpers and bystanders away from machine while working. Only properly trained people should operate this machine.

NO PASSENGERS ALLOWED - Do not carry passengers anywhere on, or in, the tractor or equipment, except as required for operation. There is no safe place for any riders.

Keep hands and clothing clear of moving parts.

When halting operation, even periodically, set the tractor or towing vehicle brakes, disengage the PTO, shut off the engine and remove the ignition key. Never leave equipment unattended with the tractor running.

Never stand alongside of unit with engine running or attempt to start engine and/or operate machine while standing alongside unit.

Keep hands and clothing clear of moving parts.

DO NOT clean, lubricate or adjust your equipment while it is moving.

DO NOT walk or work under raised components unless securely positioned and blocked.

Be especially observant of the operating terrain. Always inspect the area prior to operation. Stay alert for uneven terrain, holes, rocks, and roots and other hidden hazards. Keep away from drop-offs and hazards that could cause roll over.

Use extreme care and maintain minimum ground speed when transporting or operating on hillsides. Do not operate near the edge of drop offs or banks. Be careful and slow down when turning sharp corners and changing direction on slopes. Do not start or stop suddenly on slopes. Avoid operation on steep slopes. Practice will improve your skills in maneuvering on rough terrain. Always cut down slopes, never across the face. Always check tractor manual for proper use on slopes.

Always maneuver the equipment at safe speeds.

2.7 TRANSPORT SAFETY

1. Comply with state and local laws governing highway safety and movement of farm machinery on public roads. Never allow riders on tractor or implement.
2. The use of flashing amber lights is acceptable in most localities. However, some localities prohibit their use. Local laws should be checked for all highway lighting and marking requirements.
3. Various safety lights and devices are available from your dealer.
4. At all times, when driving the tractor and equipment on the road or highway under 20 mph (32 kph) use flashing amber warning lights and a slow moving vehicle (SMV) identification emblem. Do not exceed 20 mph (32 kph). Reduce speed on rough roads and surfaces.
5. Plan your route to avoid heavy traffic.
6. Always install transport locks, pins, or brackets before transporting. Always be sure the drag scraper is in the fully raised position when in transport.
7. Do not drink and drive.
8. Be a safe and courteous driver. Always yield to oncoming traffic in all situations, including narrow bridges, intersections, etc. Watch for traffic when operating near or crossing roadways.
9. Turn into curves or go up or down hills only at a low speed and at a gradual steering angle. Make certain that at least 20% of the tractor's weight is on the front wheels to maintain safe steering. Slow down on rough or uneven surfaces.

2.8 STORAGE SAFETY

Following operation, or when unhitching, stop the tractor or towing vehicle, set the brakes, disengage the PTO and all power drives, shut off the engine and remove the ignition keys.

1. Store the unit in an area away from human activity. Do not permit children to play on or around the stored unit.
2. Do not park equipment where it can be exposed to direct contact to livestock for long periods of time. Damage and livestock injury could result.
3. Make sure all parked machines are on a hard, level surface and engage all safety devices. Wheel chocks may be needed to prevent unit from rolling.

2.9 MAINTENANCE SAFETY

1. Good maintenance is your responsibility. Poor maintenance is an invitation to trouble.
2. Follow good shop practices.
 - Keep service area clean and dry.
 - Be sure electrical outlets and tools are properly grounded.
 - Use adequate light for the job at hand.
3. Do not allow grease or oil to build up on any step or platform.
4. Before working on this machine, disengage PTO, shut off the engine, set the brakes, and remove the ignition key. Be certain all moving parts on attachments have come to a complete stop before attempting to perform maintenance.
5. Always use a safety support to block the wheels. Use extreme caution when making adjustments.
6. Always use the proper tools or equipment for the job at hand. Use personal protection devices such as eye, hand, and hearing protectors, when performing any service or maintenance work.
7. Where replacement parts are necessary for periodic maintenance and servicing, genuine factory replacement parts **must** be used to restore your equipment to original specifications. The manufacturer will not be responsible for injuries or damages caused by use of unapproved parts and/or accessories.
8. A fire extinguisher and first aid kit should be kept readily accessible while performing maintenance on this equipment



9. Never use your hand to locate a hydraulic leak on attachments. Use a small piece of cardboard or wood. Hydraulic fluid escaping under pressure can penetrate the skin. Openings in the skin and minor cuts are susceptible to infection from hydraulic fluid. If injured by the escaping hydraulic fluid, see a doctor at once. Without immediate medical treatment, serious infection can occur.
10. When completing a maintenance or service function, be sure all tools, parts, and service equipment are removed from scraper, and make sure all safety shields and devices are installed before placing unit in service.

3 ASSEMBLY & OPERATION

3.1 ATTACHING UNIT



WARNING - NEVER STAND BETWEEN TRACTOR AND SCRAPER WHILE BACKING UP TRACTOR TO THE HITCH.

1. Bolt the cam link assembly to the wheel lift assembly as shown in the parts illustration. The cam link bolts should have locking nuts. Do not over tighten the bolt assembly, as the cam link assembly needs to move freely.
2. Connect the tongue to the scraper, using eight bolts.
3. Now hook up the planing scraper to the tractor drawbar. When properly set, the wings of the bucket will be parallel with the ground.
4. Mount the tires to the hubs with the rim disc offset toward the hub to ensure proper clearance between tire and frame; and bolt to the hubs using 4 nuts.
5. Connect a 6" stroke implement cylinder to your scraper with the shaft end connected to the cam link. A 2 x 6 hydraulic implement cylinder is available as an option.

Periodically tighten all bolts and nuts to ensure drag scraper is in a safe working condition.

4 SERVICE & MAINTENANCE

4.1 SERVICING INSTRUCTIONS

Lower drag scraper to ground, set tractor locking system device, turn tractor engine off, and remove key before performing any service or maintenance. Where replacement parts are necessary for periodic maintenance and servicing, genuine factory replacement parts must be used to restore your equipment to original specifications. The manufacturer will not claim responsibility for use of unapproved parts and/or accessories and other damages as a result of their use.

- Block drag scraper securely before working underneath.
- Never replace hex bolts with less than grade five bolts unless otherwise specified.
- Periodically tighten all bolts and nuts to ensure scraper is in a safe working condition.
- Before operating the scraper, always check to make sure that the lynch pins are in the lock position, so that the lift pins do not work their way out.
- Keep all persons away from operator control area while performing adjustments, service or maintenance.

4.2 CUTTING EDGE REPLACEMENT

Cutting edges are reversible so always remember to "flip" them over before wearing the back plate. Replace the cutting edge after both edges are worn to the bottom edge of the back plate.

For reversing the cutting edge:

- Remove 5/8" plow bolts
- Remove cutting edge from moldboard and reinstall with sharp edge down
- Replace when both edges are worn out

4.3 BOLTS AND TORQUE SPECIFICATIONS

BOLTS -

Keep all the bolts tight at all times by checking them periodically. Replace the bolts only with those having the same marks on the heads as on original bolt. Marks on bolt head indicate high strength.

<u>BOLT</u>	<u>MINIMUM</u>	<u>MAXIMUM</u>
5/8"	150 ft./lbs.	180 ft./lbs.

5 REPLACEMENT PARTS

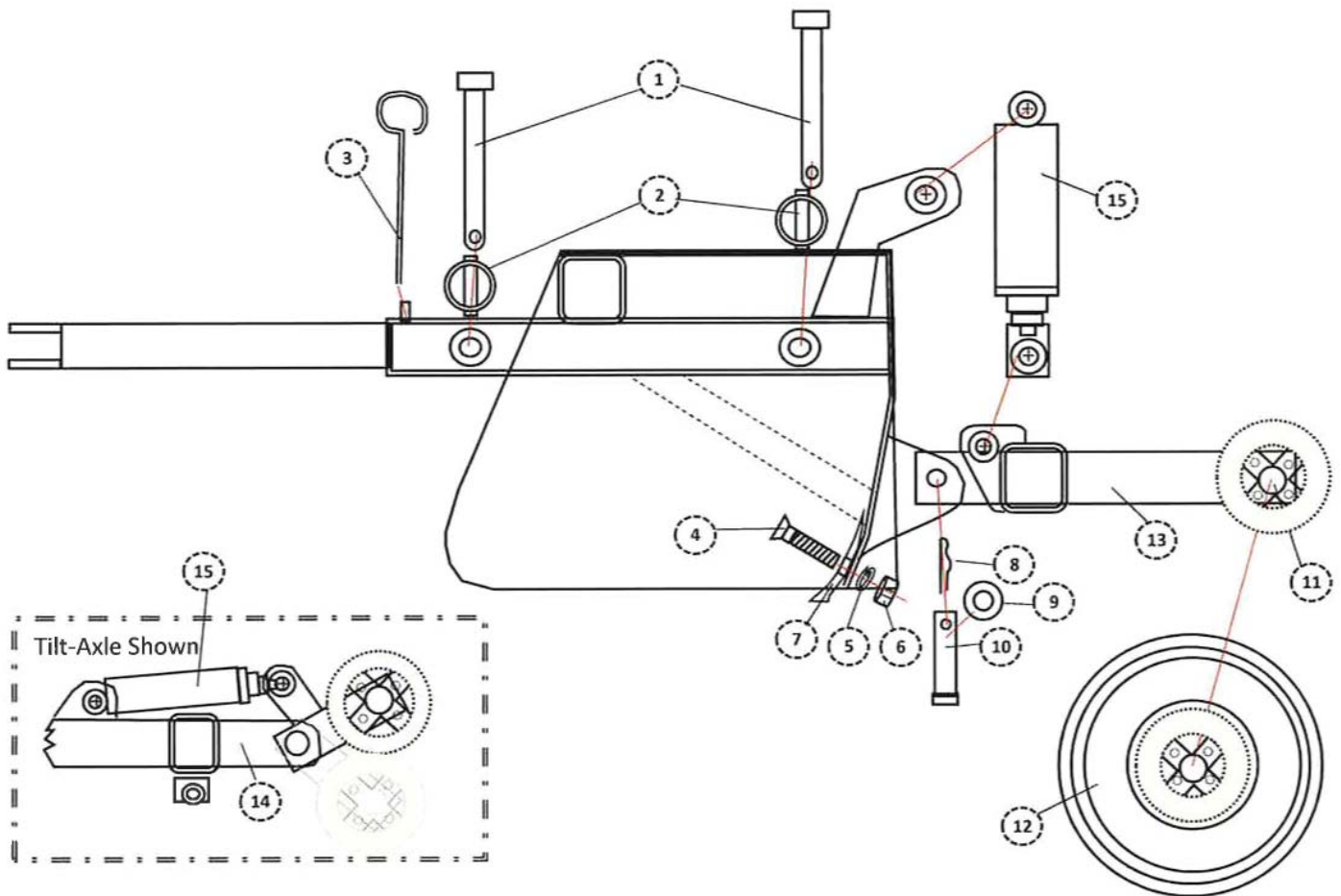

Ref.	Quantity			Part No.	Description
	5	6	7		
1	2	2	2	AP100500C2TL	Cat. II Top Link
2	2	2	2	P716175LY	Lynch Pin
3	1	1	1	R01DS763	Pig Tail
4	5	6	7	B058200P	5/8" x 2" Plow Bolts
5	5	6	7	W058L	Lock Washer
6	5	6	7	N058H	Hex Nut
7	1			CE60	60" Cutting Edge
7		1		CE72	72" Cutting Edge
7			1	CE84	84" Cutting Edge
8	2	2	2	P11	Hair Pins
9	4	4	4	W100SAEF	Pivot Ear Washer
10	2	2	2	P100258CLP	1 x 2 15/16" Plated Clevis Pin
11	2	2	2	HUBT8	Small 4 Lug Hub
12	2	2	2	WH5708	Small Tire Set
13	1	1	1	AX007	No Tilt Axle
14	1	1	1	TKA-01	Tilt Axle
15				2x6	2 x 6" Cylinder (Tilt Option)
16	2	2	2	R104BT8	Spindle (Not Shown)

6 LIMITED WARRANTY



GEARMORE, INC., warrants each new Gearmore product to be free from defects in material and workmanship for a period of twelve (12) months from date of purchase to the original purchaser. This warranty shall not apply to implements or parts that have been subject to misuse, negligence, accident, or that have been altered in any way.

Our obligation shall be limited to repairing or replacement of any part, provided that such part is returned within thirty (30) days from date of failure to Gearmore through the dealer from whom the purchase was made, transportation charges prepaid.

This warranty shall not be interpreted to render us liable for injury or damages of any kind or nature, direct, consequential or contingent, to person or property. This warranty does not extend to loss of crops, loss because of delay in harvesting or any other expenses, for any other reasons.

Gearmore in no way warrants engines, tires, or other trade accessories, since these items are warranted separately by these respective manufacturers.

Gearmore reserves the right to make improvements in design or changes in specification at any time, without incurring any obligations to owners or units previously sold.

Please be advised that all warranty work done by your dealer must be approved by Gearmore before work begins.

GEARMORE, INC.
13477 Benson Ave.
Chino, CA 91710

Always refer to and heed machine operating warning decals on machine.

*To validate the warranty on this product, please log-in to our website - www.gearmore.com.
You will find "warranty registration" listed at the top of our homepage.*