

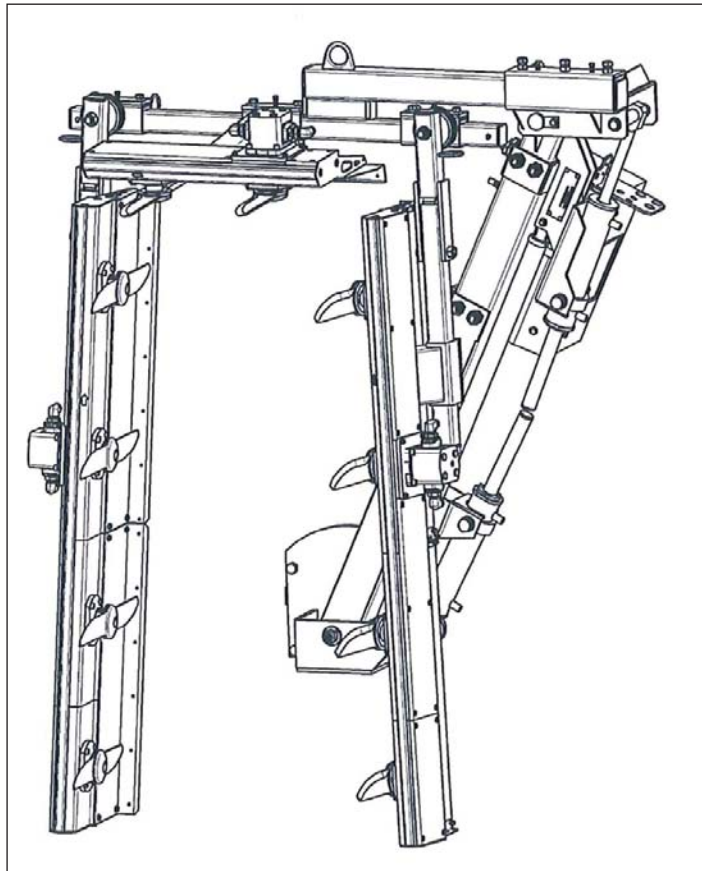

**COLLARD®**

# VINE TRIMMERS



## PARTS MANUAL FOR P3000LZP CODE #0111 0450 SINGLE ROW

*Marketed by:*



13477 Benson Ave. • Chino, CA • Ph: 909/548-4848 • Fax: 909/548-4747

# TABLE OF CONTENTS

<u>SECTION</u>	<u>DESCRIPTION</u> .....	<u>PAGE</u>
1	<b>Introduction</b> .....	<b>1</b>
1.1	Operator's Responsibility .....	1
2	<b>Spare Parts - Frames</b> .....	<b>2 - 13</b>
2.1	Chassis LZP Standard ..... (PL 4151) .....	2
2.2	Vertical Chassis ..... (PL 2306) .....	3
2.3	Standard Reinforced Frame ..... (PL 3904) .....	4
2.4	Chassis ..... (PL 2307) .....	5
2.5	Chassis ..... (PL 2308) .....	6
2.6	Cutting Element Support ..... (PL 3902) .....	7
2.7	Vertical Arm LH ..... (PL 2294) .....	8
2.8	Vertical Arm RH ..... (PL 2295) .....	9
2.9	Retractable Arm ..... (PL 2258) .....	10
2.10	Top Element Support ..... (PL 3650) .....	11
2.11	Complete Angle Brake Assy ..... (PL 4365) .....	12
2.12	P3000LZP With Standard Frame ..... (PL 4150) .....	13
3	<b>Spare Parts - Cutting Elements</b> .....	<b>14 - 19</b>
3.1	63" Cutting Element LH ..... (PL 3550) .....	14-15
3.2	63" Cutting Element RH ..... (PL 3548) .....	16-17
3.3	30.7" Cutting Element ..... (PL 3552) .....	18
3.4	Plastic Protection Kit ..... (PL 3665) .....	19
3.5	Complete Closing ..... (PL 3542) .....	20
3.6	Hydraulic Motor 10cc ..... (PL 3539) .....	21
3.7	Blade Assy Long LH..... (PL 3543) .....	22
3.8	Blade Assy Long RH..... (PL 3540) .....	23
3.9	Motor Blade Assy Short RH..... (PL 3541) .....	24
3.10	Motor Blade Assy Short LH..... (PL 3555) .....	25
3.11	Blade Hsg. Assy Long RH..... (PL 3556) .....	26
3.12	Blade Hsg. Assy Long LH..... (PL 3558) .....	27
3.13	Motor Blade Hsg. Assy Short RH..... (PL 3557) .....	28
3.14	Motor Blade Hsg. Assy Short LH..... (PL 3559) .....	29
4	<b>Hydraulic Parts</b> .....	<b>30 - 32</b>
4.1	Double Effect Cylinder ..... (PL 2316) .....	30
4.2	Cylinder DE 35 - 25 ..... (PL 2317) .....	31
4.3	Hydraulic Unit ..... (PL 3878) .....	32
4.4	Electric Control Handle With Cross Lever .....	33

# 1 INTRODUCTION

Congratulations on your selection of a Collard Vine Trimmer.

## **HISTORY**

The COLLARD family has been servicing grape growers for 5 generations. Andre Collard invented the first mechanical vine trimmer in 1962. Since that development COLLARD has made numerous improvements and continues to be the world leader in trimmers.

## **QUALITY CONTROL**

Every stage in the production process is controlled to guarantee superior quality. After final assembly, each machine is run through a detailed test where everything is checked - rotation speed, operating pressure, hydraulic cylinders, flow rates, etc. All this is done to insure that every machine leaving the factory is in perfect working order.



## 1.1 OPERATOR'S RESPONSIBILITY

Safe, efficient and trouble free operation of your Vine Trimmer requires that you and anyone else who will be operating or maintaining the machine, read and understand the Safety, Installation, Operation, Maintenance, and Troubleshooting information contained within the Operator's Manual.

Keep this manual handy for frequent reference and to pass on to new operators or owners. Call your tractor dealer if you need assistance, information or additional copies of the manuals.

**OPERATOR ORIENTATION** - The directions left, right, front and rear, as mentioned throughout this manual, are as seen from the driver's seat and facing in the direction of travel.

NAME: \_\_\_\_\_

PURCHASED FROM: \_\_\_\_\_

DATE OF PURCHASE: \_\_\_\_\_

CODE NUMBER: \_\_\_\_\_

SERIAL NUMBER: \_\_\_\_\_

## 2 SPARE PARTS - FRAMES

### 2.1 CHASSIS LZP STANDARD - CODE 0110 0101

PL 4151

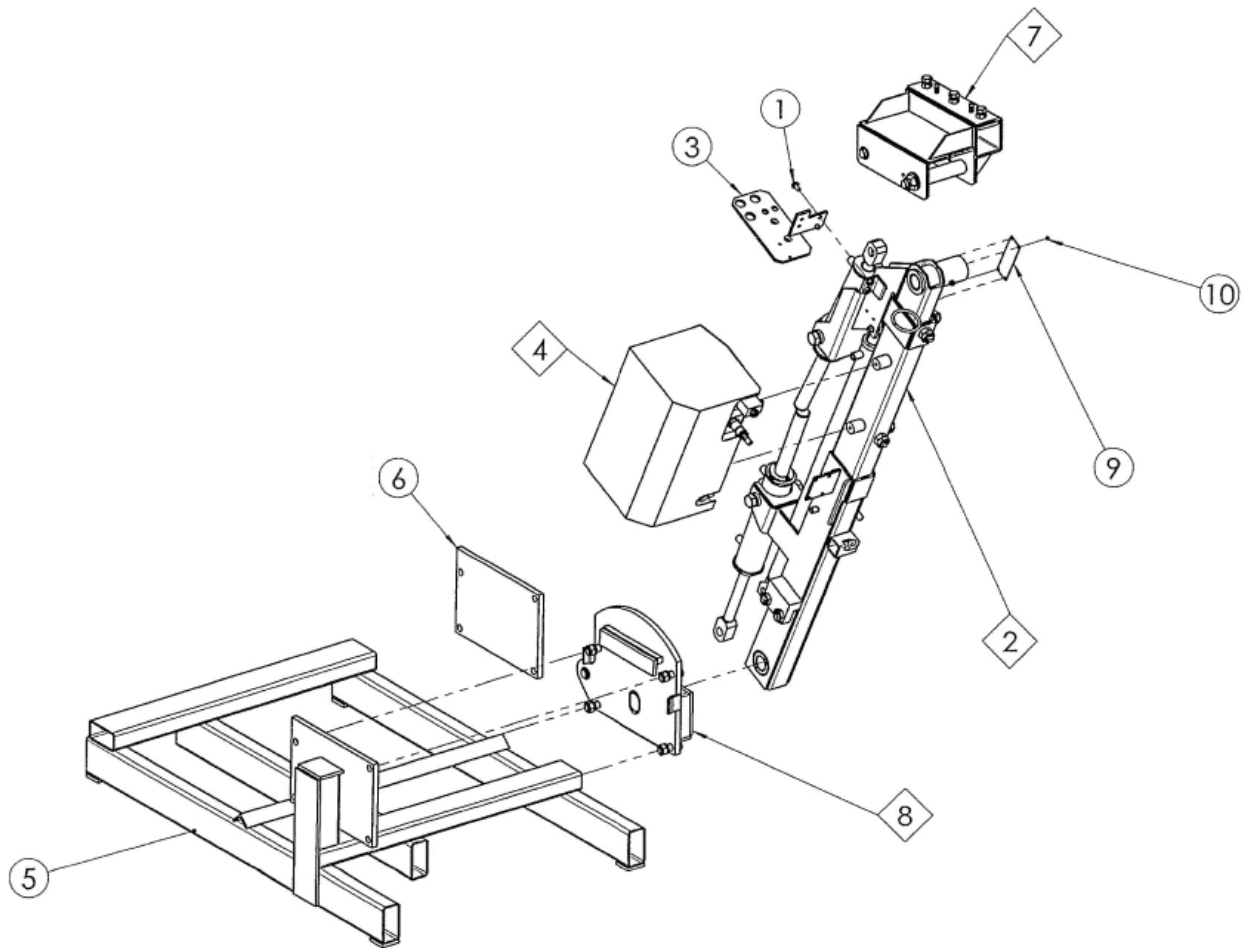

<u>REF #</u>	<u>QTY.</u>	<u>PART NO.</u>	<u>DESCRIPTION</u>	<u>ASSY.</u>
1	2	05011877	Screw Tensilok M8 x 16 Zn	
2	1	00730220	Vertical Chassis	PL 2306 - Pg 3
3	1	00730267	Bulkhead	
4	1	00730239	Distributor Assy	PL 3904 - Pg 4
5	1	00006330	Storage Support	
6	1	00730126	Fixing Plate	
7	1	00730219	Upper Bracket Assy	PL 2307 - Pg 5
8	1	00730221	Base Assy	PL 2308 - Pg 6
9	1	05016066	Compliance Plate	
10	4	05011650	Rivet POP Ø4 x 8	

## 2 SPARE PARTS - FRAMES

### 2.2 VERTICAL CHASSIS - CODE 0073 0220

PL 2306

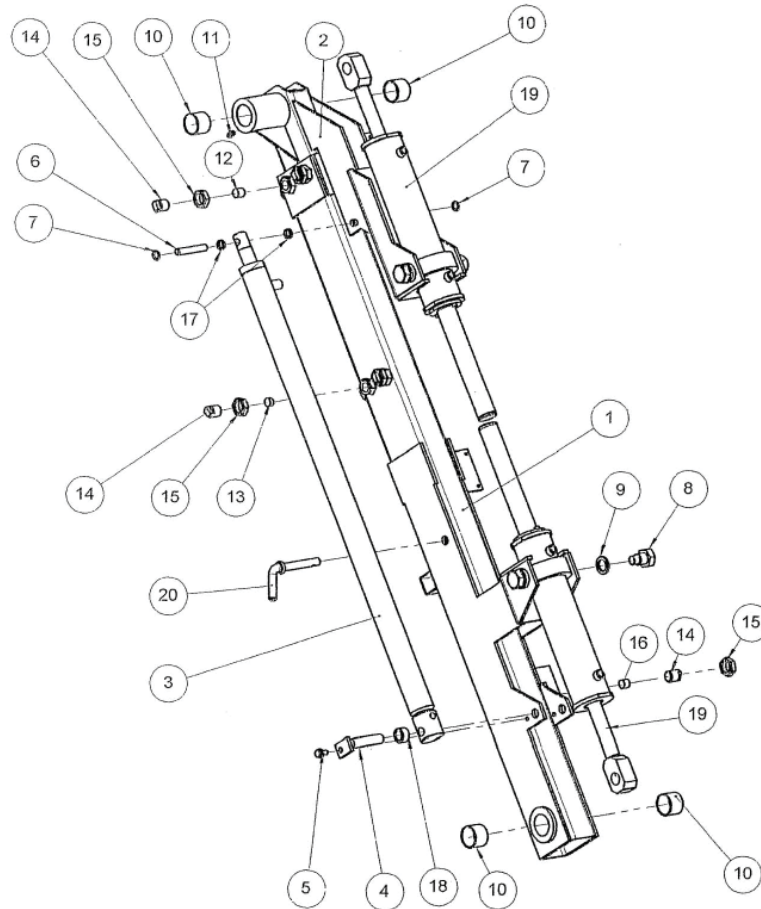

<u>REF #</u>	<u>QTY.</u>	<u>PART NO.</u>	<u>DESCRIPTION</u>	<u>ASSY.</u>
1	1	00730206	Female Frame	
2	1	00730204	Male Frame	
3	1	05019776	Cylinder DE 35 - 18 C=800	PL 2317 - Pg 31
4	1	00730215	Low Cylinder Axix	
5	1	05011877	Screw Tensilok M8 x 16 Zn	
6	1	00730216	Axle	
7	2	05014318	Washer Self Locking Ø12	
8	4	00730012	Threaded Axis	
9	4	05015315	Washer W20	
10	4	05005384	Ring	
11	1	05016500	Right Greaser M8	
12	3	05014314	Plastic Plug Ø16	
13	3	05014309	Plastic Plug Ø16	
14	8	05010814	Screw M20	
15	8	05011208	Nut HU M20 Zn	
16	2	05014316	Plastic Plug Ø16 - 13mm	
17	2	05005400	Ring	
18	1	05005401	Ring	
19	2	05019751	Double Effect Cylinder 60 - 25	PL 2316 - Pg 30
20	1	05016220	Spindle Ø14 x 90	

## 2 SPARE PARTS - FRAMES

### 2.3 STANDARD REINFORCED FRAME - CODE 0073 0329

PL 3904

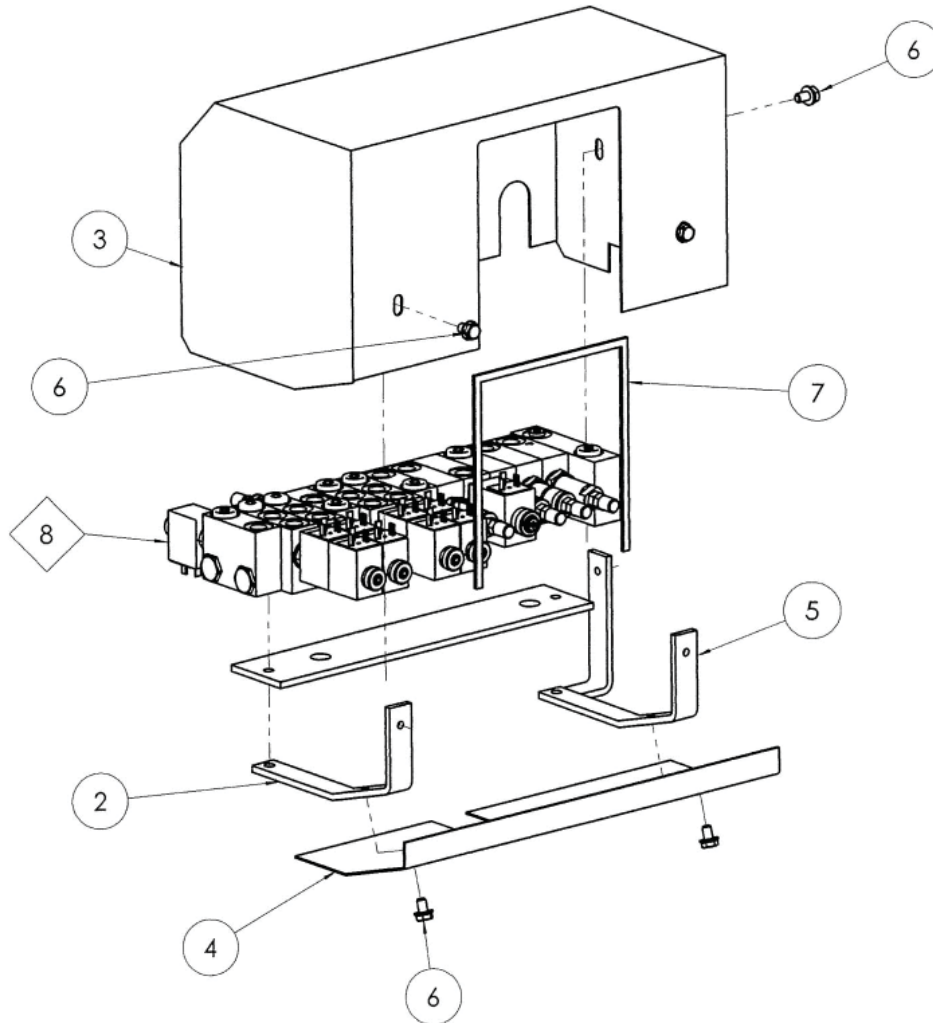

<u>REF #</u>	<u>QTY.</u>	<u>PART NO.</u>	<u>DESCRIPTION</u>	<u>ASSY.</u>
1	1	00730124	Distributor Support	
2	1	00730237	Casing Fixing	
3	1	00730232	Casing	
4	1	00730240	Casing	
5	1	00730241	Fixing	
6	5	05011861	Screw TEnsilok M8 x 12 Zn	
7	1	05000056	Flexible Protection	
8	1	05022916	Distributor	

PL 3878 - Pg 32

## 2 SPARE PARTS - FRAMES

### 2.4 CHASSIS - CODE 0073 0219

PL 2307

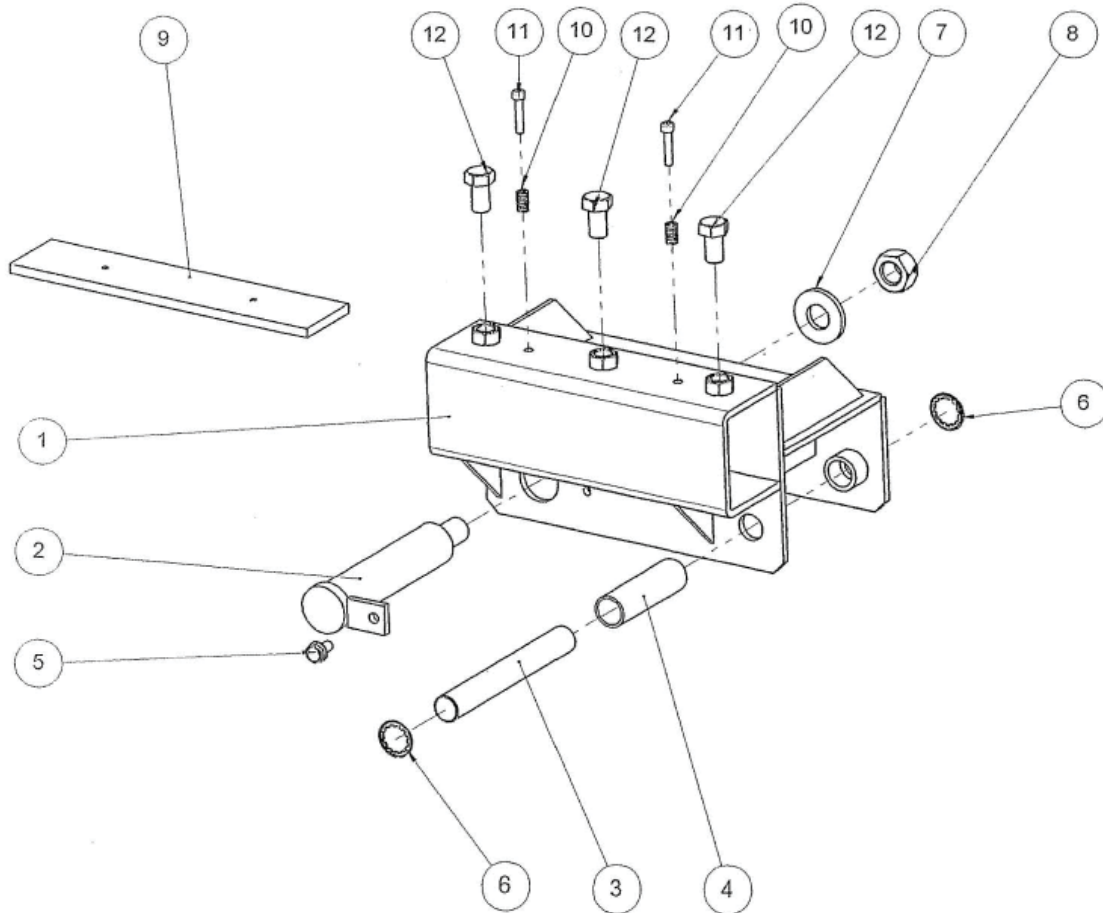

<u>REF #</u>	<u>QTY.</u>	<u>PART NO.</u>	<u>DESCRIPTION</u>	<u>ASSY.</u>
1	1	00730201	Double Clamp	
2	1	00730109	High Articulation Axle	
3	1	00730119	Round	
4	1	05005383	Tube	
5	1	05011877	Screw Tensilok M8 x 16 Zn	
6	2	05014321	Self Locking Washer	
7	1	05015033	Flat Washer	
8	1	05014301	Self Braking Nut	
9	1	05029701	Flat Bar	
10	2	05011954	Compression Spring	
11	2	05010916	Screw	
12	3	05010165	Screw	

## 2 SPARE PARTS - FRAMES

### 2.5 CHASSIS - CODE 0073 0221

PL 2308

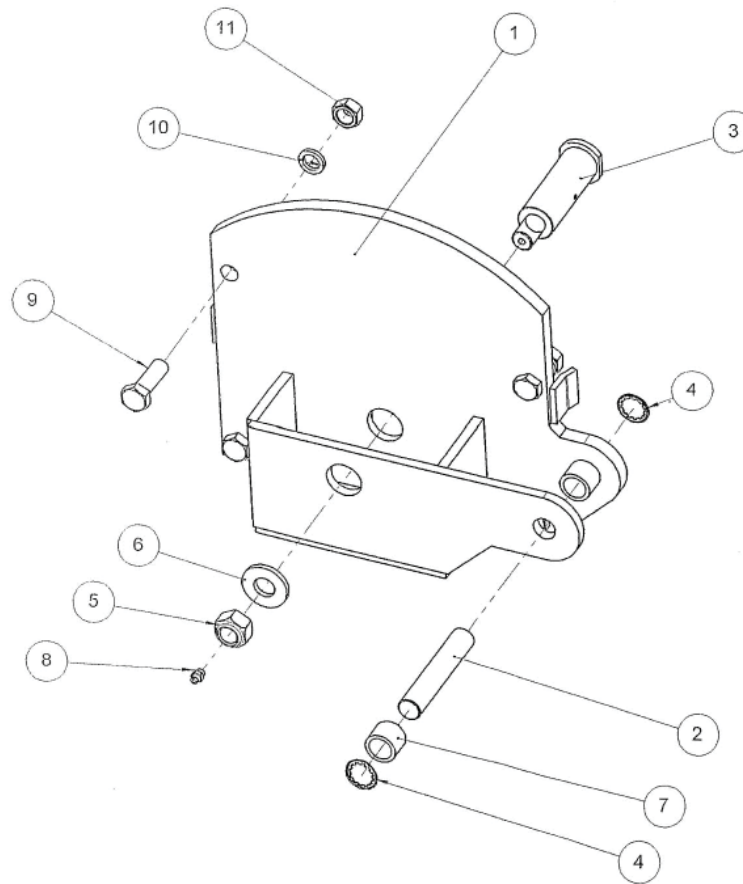

<u>REF #</u>	<u>QTY.</u>	<u>PART NO.</u>	<u>DESCRIPTION</u>
1	1	00730103	Base
2	1	00730002	Round
3	1	00730116	Round
4	2	05014321	Self Locking Washer
5	1	05014301	Self Braking Nut
6	1	05015033	Flat Washer
7	1	05005385	Tube
8	1	05016500	Nut
9	4	05010171	Screw
10	4	05015314	Washer
11	4	05011201	Nut



## 2 SPARE PARTS - FRAMES

### 2.6 CUTTING ELEMENT SUPPORT - CODE 0111 0451

PL 3902

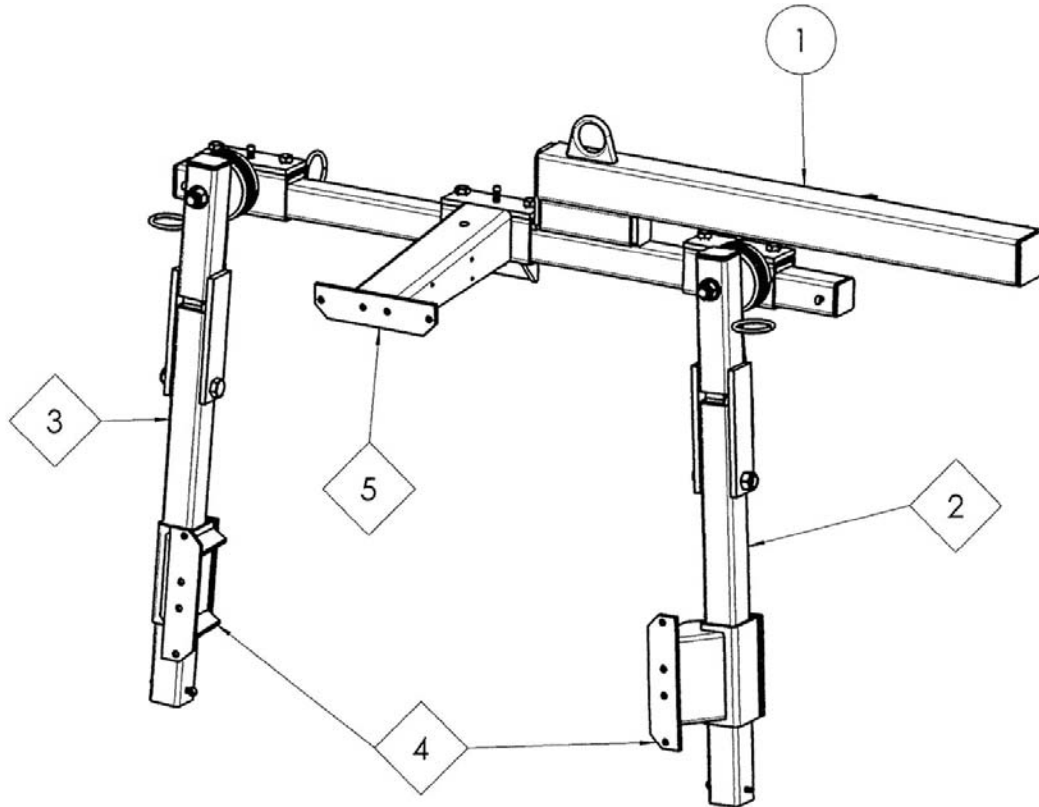

<u>REF #</u>	<u>QTY.</u>	<u>PART NO.</u>	<u>DESCRIPTION</u>	<u>ASSY.</u>
1	1	00730224	Top Cross Bar	
2	1	00480445	Vertical Arm LH	PL 2294 - Pg 8
3	1	00480444	Vertical Arm RH	PL 2295 - Pg 9
4	2	01050029	Lateral Support	PL 3650 - Pg 11
5	1	01050006	Top Support	PL 3650 - Pg 11

## 2 SPARE PARTS - FRAMES

### 2.7 VERTICAL ARM LH - CODE 0048 0445

PL 2294

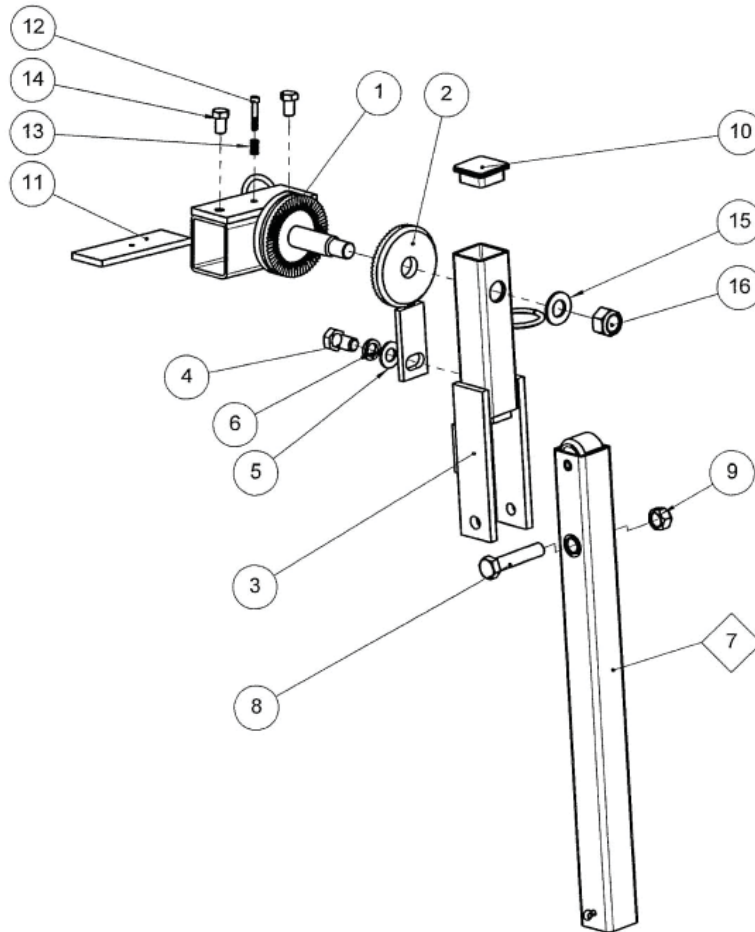

<u>REF #</u>	<u>QTY.</u>	<u>PART NO.</u>	<u>DESCRIPTION</u>	<u>ASSY.</u>
1	1	01050209-BIS		
2	1	01050213	Articulation	
3	1	01050222	Arm Support	
4	1	05010120	Screw TH M16 x 30	
5	1	05015016	Washer M16 Zn	
6	1	05015314	Washer W16	
7	1	00523311	Complete Vertical Arm	PL 2258 - Pg 10
8	1	05010008	Screw TH M16 x 80 Zn	
9	1	05014307	Locknut M16	
10	1	05017869	Cap	
11	1	05029543	Attachment Wedge	
12	1	05010942	Screw CHC M6 x 35	
13	1	05011954	Compressing Spring	
14	2	05010007	Screw TH M12 x 20 Zn	
15	1	05015022	Washer M20 Zn	
16	1	05014301	Locknut M20 x 250	

## 2 SPARE PARTS - FRAMES

### 2.8 VERTICAL ARM RH - CODE 0048 0444

PL 2295

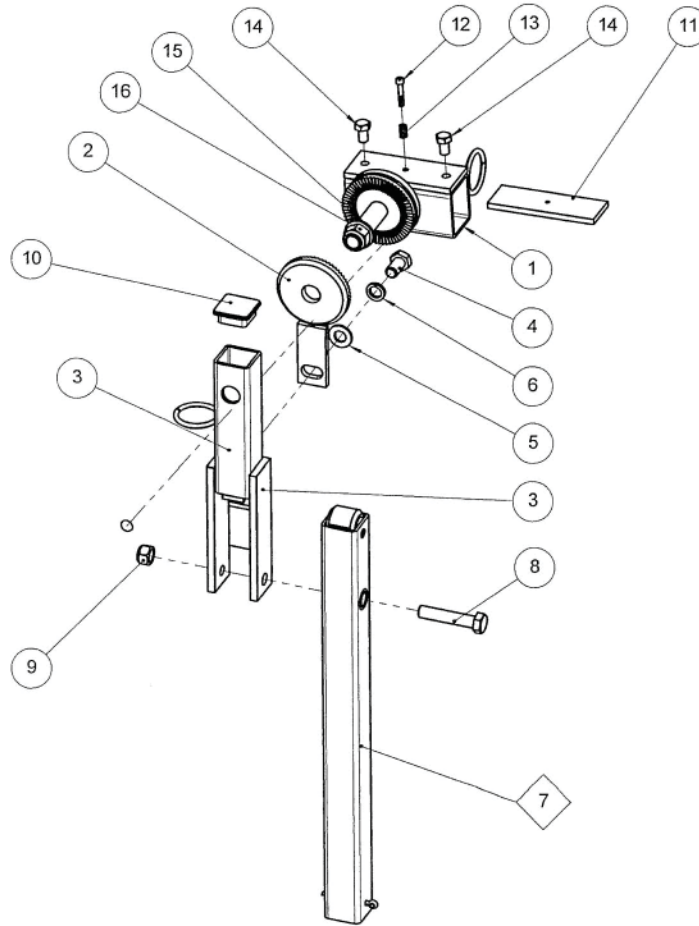

<u>REF #</u>	<u>QTY.</u>	<u>PART NO.</u>	<u>DESCRIPTION</u>	<u>ASSY.</u>
1	1	01050209		
2	1	01050213	Articulation	
3	1	01050222-BIS	Arm Support	
4	1	05010120	Screw TH M16 x 30	
5	1	05015016	Washer M16 Zn	
6	1	05015314	Washer W16	
7	1	00523311	Complete Vertical Arm	PL 2258 - Pg 10
8	1	05010008	Screw TH M16 x 80 Zn	
9	1	05014307	Locknut M16	
10	1	05017869	Cap	
11	1	05029543	Attachment Wedge	
12	1	05010942	Screw CHC M6 x 35	
13	1	05011954	Compressing Spring	
14	2	05010007	Screw TH M12 x 20 Zn	
15	1	05015022	Washer M20 Zn	
16	1	05014301	Locknut M20 x 250	

## 2 SPARE PARTS - FRAMES

### 2.9 RETRACTABLE ARM - CODE 0052 3311

PL 2258

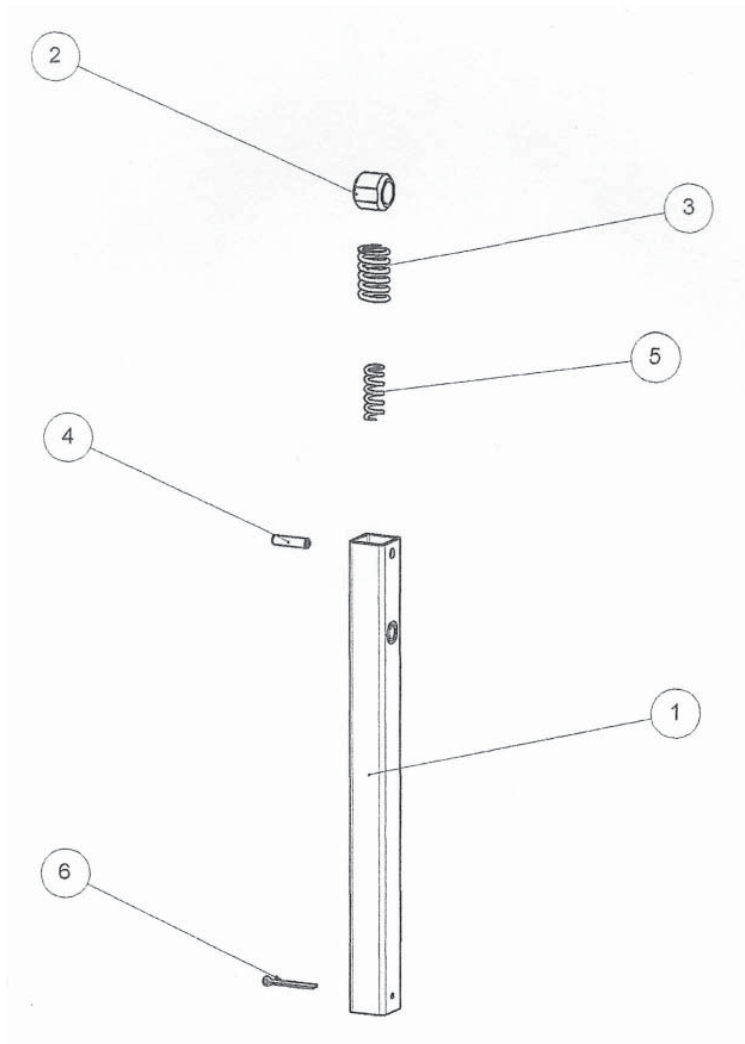

<u>REF #</u>	<u>QTY.</u>	<u>PART NO.</u>	<u>DESCRIPTION</u>
1	1	00523304	Vertical Retractable Arm
2	1	00480020	Tube Ø45 x 28
3	1	05011966	Compression Spring
4	1	05014081	Elastic Bolt Pin Ø12 x 50
5	1	05011973	Compression Spring
6	1	05014112	Bolt Pin V 6 x 70

## 2 SPARE PARTS - FRAMES

### 2.10 TOP ELEMENT SUPPORT - CODE 0105 0006

PL 3650

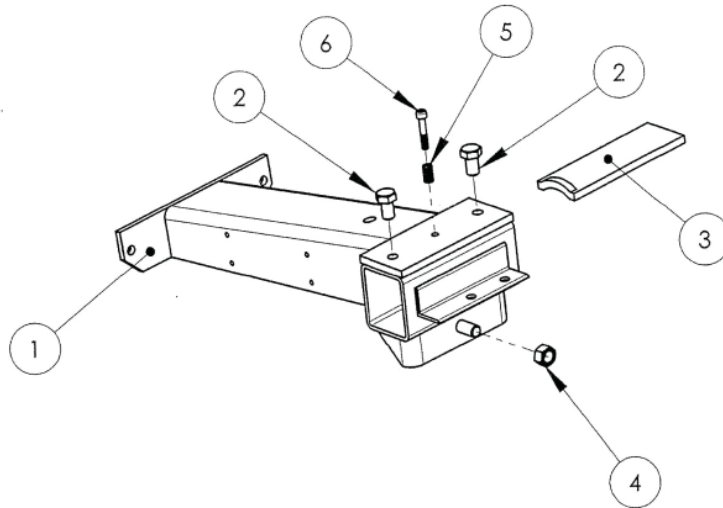

<u>REF #</u>	<u>QTY.</u>	<u>PART NO.</u>	<u>DESCRIPTION</u>
1	1	01050103	Top Element Support
2	2	05010007	Screw TH M12 x 20 Zn
3	1	05029505	Flat Bar
4	1	05011203	Nut M12 Hu
5	1	05011954	Compressing Spring
6	1	05010942	Screw CHC M6 x 35

### LATERAL ELEMENT SUPPORT - CODE 0105 0029

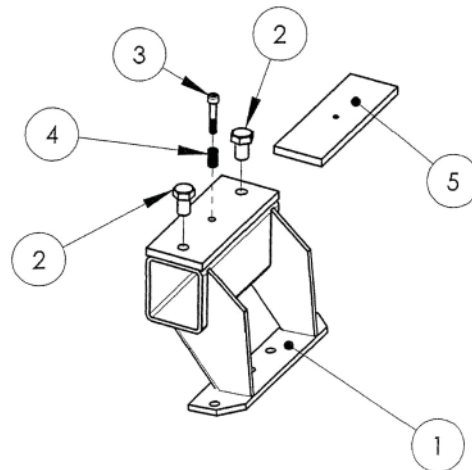

<u>REF #</u>	<u>QTY.</u>	<u>PART NO.</u>	<u>DESCRIPTION</u>
1	1	01050034	Lateral Support
2	2	05010007	Screw TH M12 x 20 Zn
3	1	05010942	Screw CHC M6 x 35
4	1	05011954	Compressing Spring
5	1	05029543	Attachment Wedge

## 2 SPARE PARTS - FRAMES

### 2.11 COMPLETE ANGLE BRAKE ASSY - CODE 0500 9086

PL 4365

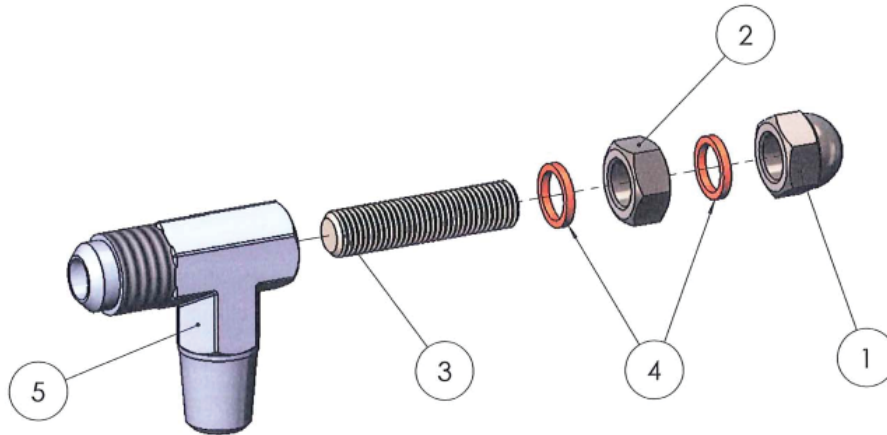

<u>REF #</u>	<u>QTY.</u>	<u>PART NO.</u>	<u>DESCRIPTION</u>
1	1	05011204	Nut M8
2	1	05011206	Nut M8 Hu
3	1	05010830	Screw STHC M8 x 35
4	2	05002009	Joint Ø8.2 x 11.2 x 1
5	1	05009081	Angle 9/16" JIC

#### Adjustment of the feeding flow on cylinder

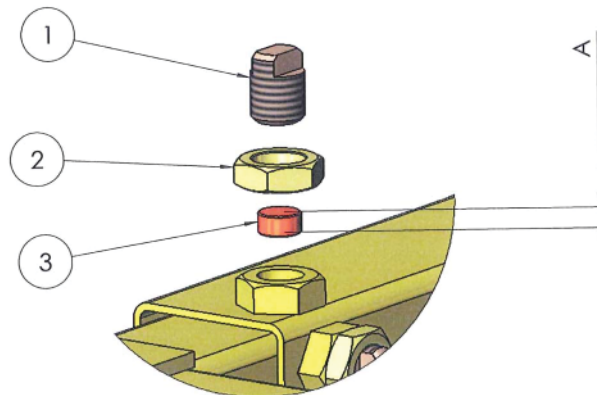

<u>REF #</u>	<u>QTY.</u>	<u>PART NO.</u>	<u>DESCRIPTION</u>	<u>DIMENSION A</u>
1	1	05010814	Screw M20	
2	1	05011208	Nut Hu M20 Zn	
3	1	05014315	Plastic Plug	4 mm
	1	05014309	Plastic Plug	8 mm
	1	05014316	Plastic Plug	12 mm
	1	05014314	Plastic Plug	16 mm

#### Adjustment of play on sliding tube

## 2 SPARE PARTS - FRAMES

### 2.12 P3000LZP WITH STD. FRAME

PL 4150

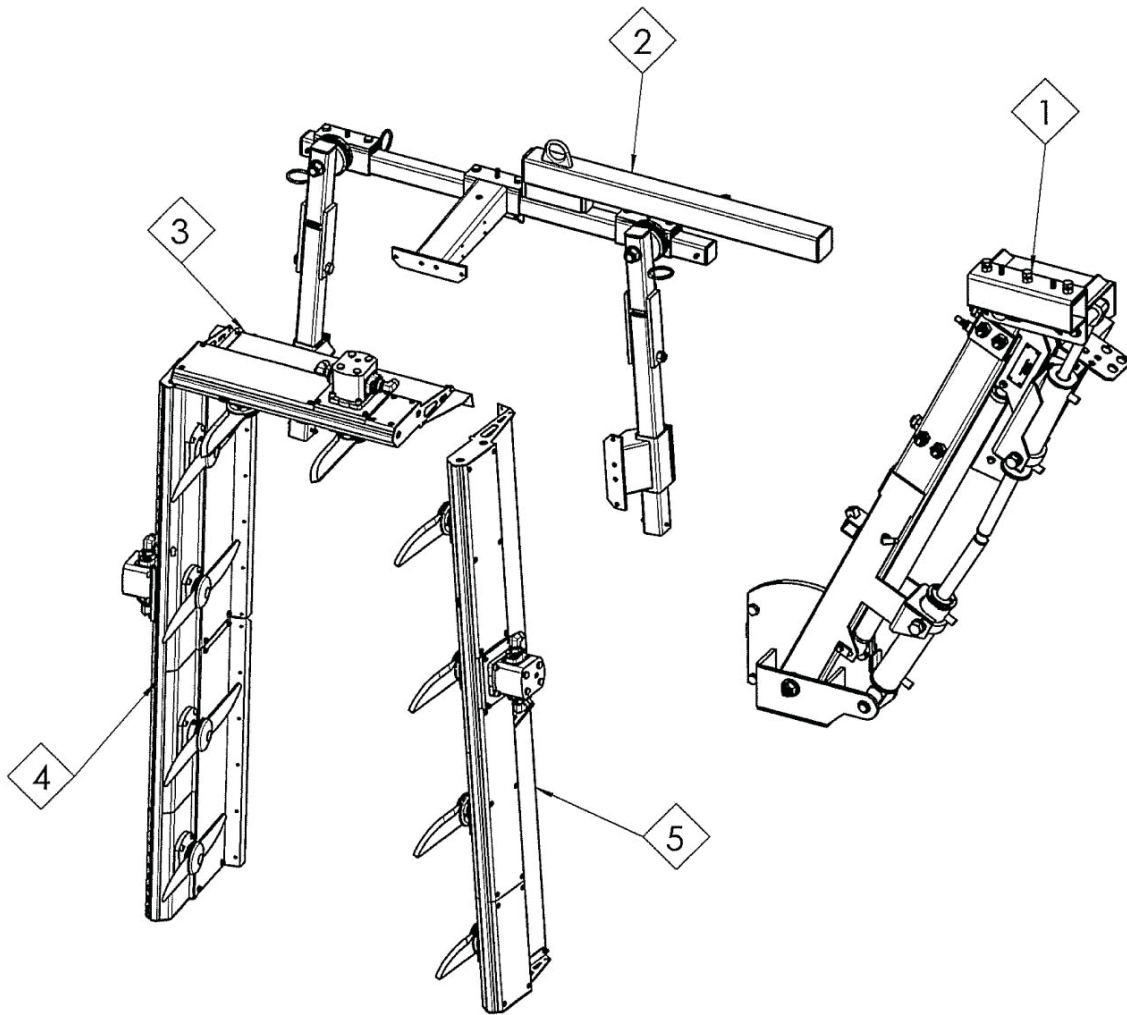

<u>REF #</u>	<u>QTY.</u>	<u>PART NO.</u>	<u>DESCRIPTION</u>	<u>ASSY.</u>
1	1	01100101	LZP Frame	PL 4151 - Pg 2
2	1	01110451	Support Cutting Element	PL 3902 - Pg 7
3	1	00001801	30.7" RH 2 Blade Cutting Element	PL 3552 - Pg 18
4	1	00001827	63" RH 4 Blade Cutting Element	PL 3548 - Pg 16
5	1	00001842	63" LH 4 Blade Cutting Element	PL 3550 - Pg 14

### 3 CUTTING ELEMENTS

#### 3.1 63" CUTTING ELEMENT, 4 BLADE - CODE 0000 1842

PL 3550

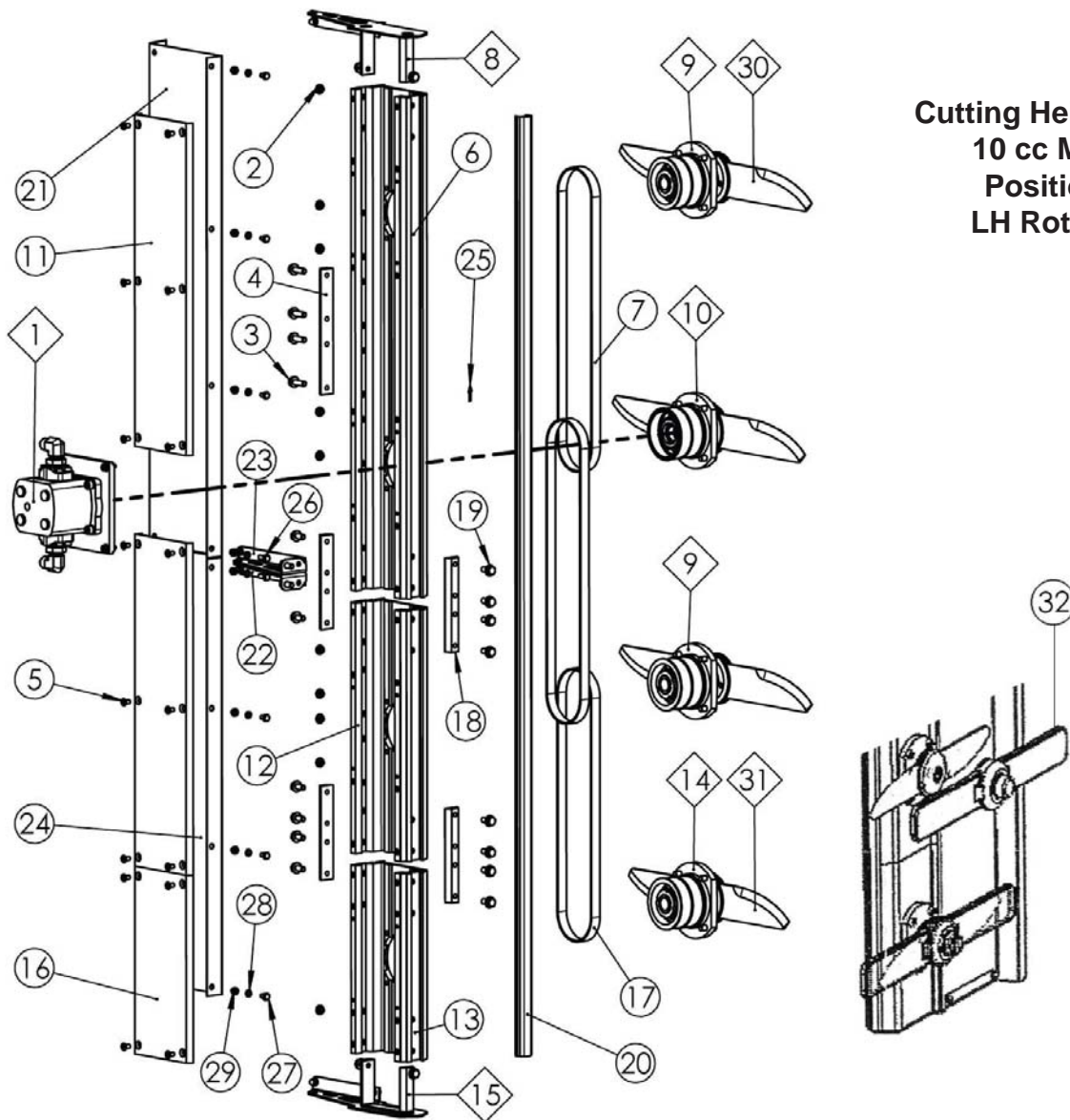

Cutting Height - 63"  
10 cc Motor  
Position 2  
LH Rotation

REF #	QTY.	PART NO.	DESCRIPTION	ASSY.
1	1	0105 0131	Motor 10cc	PL 3539 - Pg 21
2	10	05017891	Plastic Obturator	
3	4	05011876	Screw Tensilok M8 x 25 Zn	
4	1	00420016	Junction L=200mm	
5	16	05010537	Screw FHC M6 x 12	
6	1	01050046	Aluminum Section 800 mm	
7	2	05028597	Belt S 250 17 x 1039 mm	
8	1	01050018	Complete Closing With Screws	PL 3542 - Pg 20



### 3 CUTTING ELEMENTS

#### 3.1 63" CUTTING ELEMENT, 4 BLADE - CODE 0000 1842 (CONTINUED)

PL 3550

<u>REF #</u>	<u>QTY.</u>	<u>PART NO.</u>	<u>DESCRIPTION</u>	<u>ASSY.</u>
9	2	01050129	Blade Assy Long LH	PL 3543 - Pg 22
10	1	01050123	Motor Blade Assy Short LH	PL 3555 - Pg 25
11	2	01050094	Cover 530mm	
12	1	01050048	Aluminum Section 400mm	
13	1	01050047	Aluminum Section 300mm	
14	1	01050127	Blade Assy Short LH	PL 3543 - Pg 22
15	1	01050019	Complete Closing With Screws	PL 3542 - Pg 20
16	1	01050092	Cover 300mm	
17	1	05028688	Belt S 250 17 x 942mm	
18	4	01050077	Junction L=150mm	
19	14	05011877	Screw Tensilok M8 x 16	
20	1	01221500	Leading Edge 1500mm	
21	1	01050099	Blade Case 800mm	
22	1	01050008	Case Reinforcement With Screws LH	
23	1	01050009	Case Reinforcement With Screws RH	
24	1	01050098	Blade Case 700mm	
25	1	05016072	Adhesive Sticker	
26	2	05010152	Screw TH M6 x 16	
27	6	05010020	Screw TH M6 x 10	
28	8	05015318	Washer W 6	
29	8	05011234	Nut M6	
30	3	05030170	INOX Blade 480mm EL RH	
31	1	05030172	INOX Blade 400mm EL RH	
32	4	05030600	Plastic Blade Guard	

**SPECIAL NOTE:** With every stainless steel blade ordered it is recommended that the following also be ordered:

1 ea. 05030069      Mounting hardware for 1 blade consisting of:

1 ea. 05014311      Locknut M10  
 1 ea. 05017926      Plug  
 2 ea. 05011861      Screw Tensilok M8 x 12

### 3 CUTTING ELEMENTS

#### 3.2 63" CUTTING ELEMENT, 4 BLADE - CODE 0000 1827

PL 3548

Cutting Height - 63"  
10 cc Motor  
Position 2  
RH Rotation

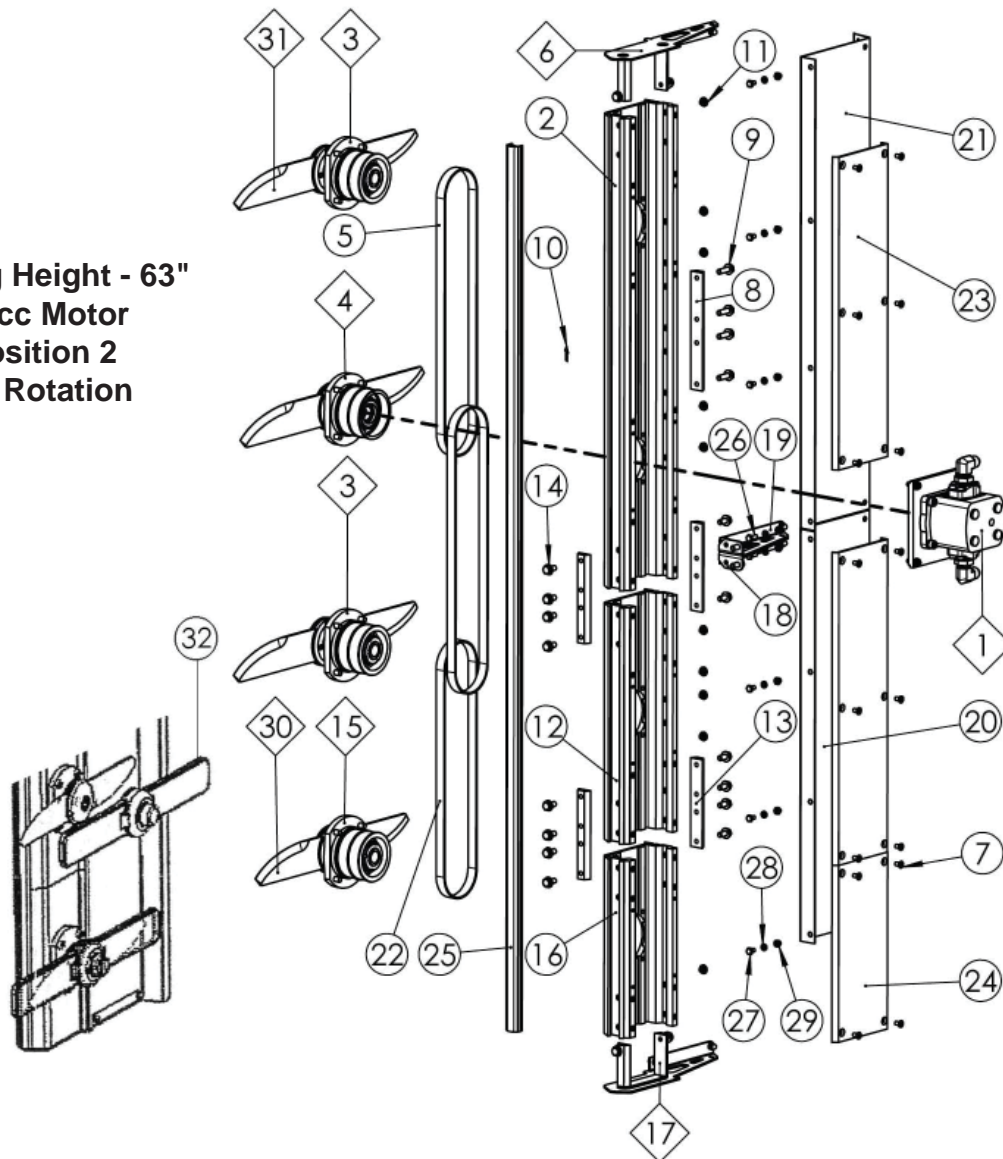

<u>REF #</u>	<u>QTY.</u>	<u>PART NO.</u>	<u>DESCRIPTION</u>	<u>ASSY.</u>
1	1	0105 0131	Motor 10cc	PL 3539 - Pg 21
2	1	01050046	Aluminum Section 800 mm	
3	2	01050130	Blade Assy Long RH	PL 3540 - Pg 23
4	1	01050124	Motor Blade Assy Short RH	PL 3541 - Pg 24
5	2	05028597	Belt S 250 17 x 1039 mm	
6	1	01050019	Complete Closing With Screws	PL 3542 - Pg 20
7	16	05010537	Screw FHC M6 x 12	
8	1	00420016	Junction L=200mm	

### 3 CUTTING ELEMENTS

#### 3.2 63" CUTTING ELEMENT, 4 BLADE - CODE 0000 1827 (CONTINUED)

PL 3548

<u>REF #</u>	<u>QTY.</u>	<u>PART NO.</u>	<u>DESCRIPTION</u>	<u>ASSY.</u>
9	4	05011876	Screw Tensilok M8 x 25 Zn	
10	1	05016072	Adhesive Sticker	
11	10	05017891	Plastic Obturator	
12	1	01050048	Aluminum Section 400mm	
13	4	01050077	Junction L=150mm	
14	14	05011877	Screw Tensilok M8 x 16	
15	1	01050128	Blade Assy Short RH	PL 3540 - Pg 23
16	1	01050047	Aluminum Section 300mm	
17	1	01050018	Complete Closing With Screws	PL 3542 - Pg 20
18	1	01050009	Case Reinforcement With Screws RH	
19	1	01050008	Case Reinforcement With Screws LH	
20	1	01050098	Blade Case 700mm	
21	1	01050099	Blade Case 800mm	
22	1	05028688	Belt S 250 17 x 942mm	
23	2	01050094	Cover 530mm	
24	1	01050092	Cover 300mm	
25	1	01221500	Leading Edge 1500mm	
26	2	05010152	Screw TH M6 x 16	
27	6	05010020	Screw TH M6 x 10	
28	8	05015318	Washer W 6	
29	8	05011234	Nut M6	
30	1	05030171	S.S. Blade 400mm EL RH	
31	3	05030169	S.S. Blade 480mm EL RH	
32	4	05030600	Plastic Blade Guard	

**SPECIAL NOTE: With every stainless steel blade ordered it is recommended that the following also be ordered:**

1 ea. 05030069      Mounting hardware for 1 blade consisting of:

1 ea. 05014311      Locknut M10  
 1 ea. 05017926      Plug  
 2 ea. 05011861      Screw Tensilok M8 x 12

### 3 CUTTING ELEMENTS

#### 3.3 30.7" CUTTING ELEMENT - CODE 0000 1801

PL 3552

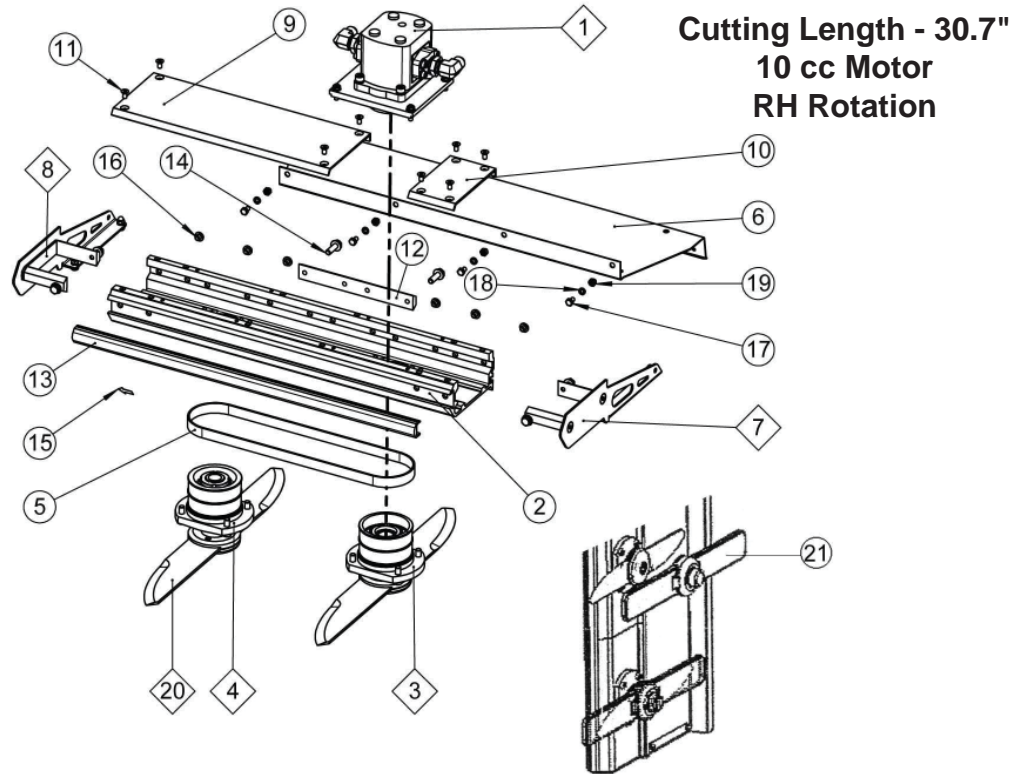

<u>REF #</u>	<u>QTY.</u>	<u>PART NO.</u>	<u>DESCRIPTION</u>	<u>ASSY.</u>
1	1	0105 0131	Motor 10 cc	PL 3539 - Pg 21
2	1	01050045	Aluminum Section 600 mm	
3	1	01050124	Motor Blade Assy Short RH	PL 3541 - Pg 24
4	1	01050130	Blade Assy Long RH	PL 3540 - Pg 23
5	1	05028596	Belt S 250 17 x 842 mm	
6	1	01050096	Blade Case 690 mm	
7	1	01050018	Complete Closing With Screws	PL 3542 - Pg 20
8	1	01050019	Complete Closing With Screws	PL 3542 - Pg 20
9	1	01050091	Cover 380 mm	
10	1	01050074	Cover 80 mm	
11	8	05010537	Screw FHC M6 x 12	
12	1	00420016	Junction L=200 mm	
13	1	01220600	Leading Edge 600 mm	
14	2	05011876	Screw Tensilok M8 x 25 Zn	
15	1	05016072	Adhesive Sticker	
16	6	05017891	Plastic Obturator	
17	4	05010020	Screw TH M6 x 10	
18	4	05015318	Washer W6	
19	4	05011234	Nut M6	
20	2	05030169	S.S. Blade 480 mm EL RH	
21	2	05030600	Plastic Blade Guard	

### 3 CUTTING ELEMENTS

#### 3.4 PLASTIC PROTECTION KIT

PL 3665

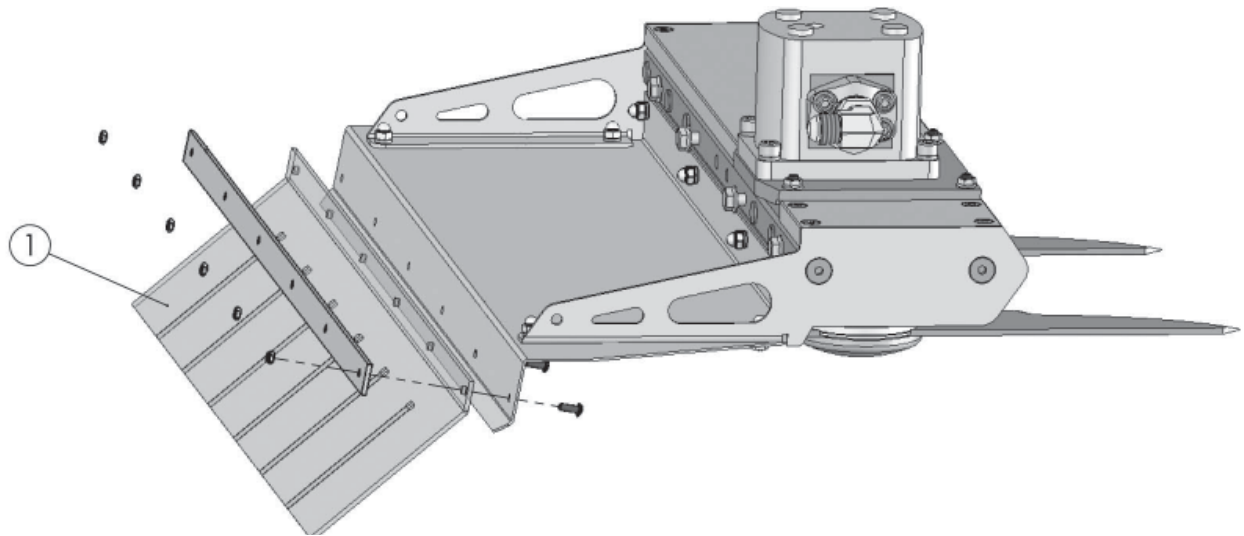

<u>REF #</u>	<u>QTY.</u>	<u>PART NO.</u>	<u>DESCRIPTION</u>
	1	00002079	Complete Kit Consisting of: 1 ea. Plastic Protection 1 ea. Fixation Plate 7 ea. Bolts M4 x 10 7 ea. Nuts M4
1	1	01050140	Replacement Plastic Only

### 3 CUTTING ELEMENTS

#### 3.5 COMPLETE CLOSING - CODE 0105 0018

PL 3542

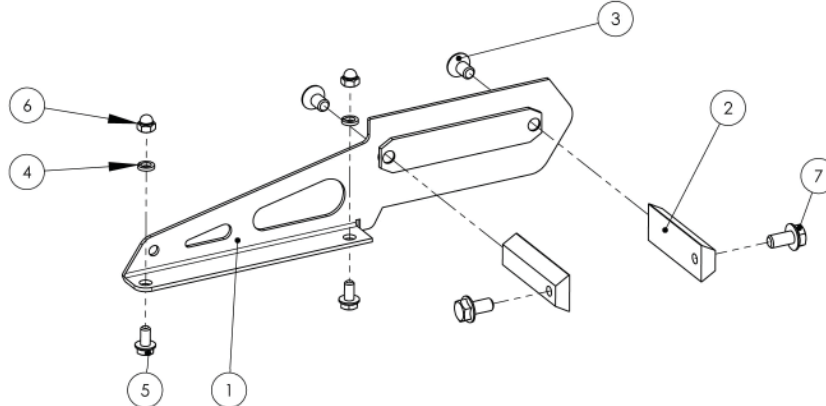

<u>REF #</u>	<u>QTY.</u>	<u>PART NO.</u>	<u>DESCRIPTION</u>
1	1	01050017	Closing
2	2	01050015	Link Part
3	2	05010501	Screw FHC M8 x 15
4	2	05015318	Washer W6
5	2	05011851	Screw Tensilok M6 x 12 Zn
6	2	05011234	Nut M6
7	2	05011877	Screw Tensilok M8 x 16

#### COMPLETE CLOSING (SYMMETRICAL) - CODE 0105 0019

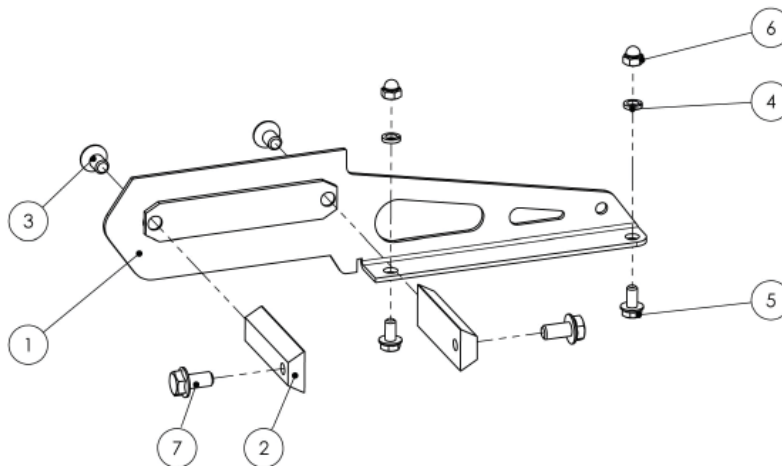

<u>REF #</u>	<u>QTY.</u>	<u>PART NO.</u>	<u>DESCRIPTION</u>
1	1	01050017	Closing
2	2	01050015	Link Part
3	2	05010501	Screw FHC M8 x 15
4	2	05015318	Washer W6
5	2	05011851	Screw Tensilok M6 x 12 Zn
6	2	05011234	Nut M6
7	2	05011877	Screw Tensilok M8 x 16

### 3 CUTTING ELEMENTS

#### 3.6 HYDRAULIC MOTOR 10CC - CODE 0105 0131

PL 3539

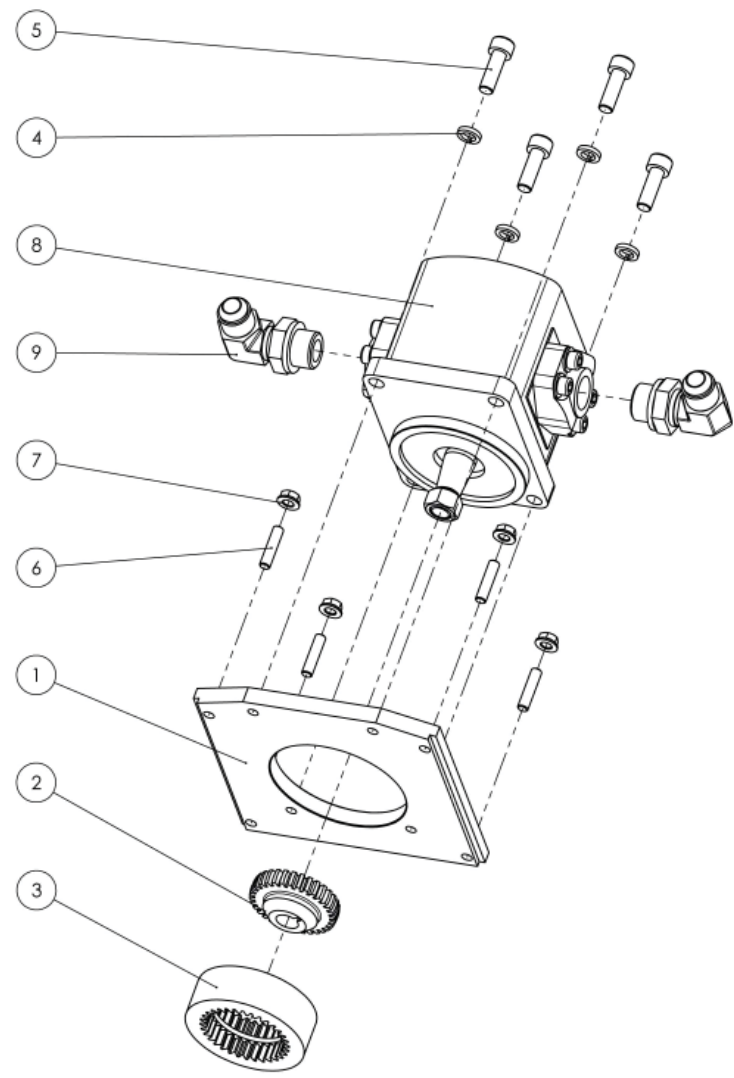

<u>REF #</u>	<u>QTY.</u>	<u>PART NO.</u>	<u>DESCRIPTION</u>
1	1	01050039	Motor Plate
2	1	01050021	Pinion With Cone
3	1	01050024	Coupling
4	4	05015317	Washer W8
5	4	05010903	Screw CHC M8 x 25
6	4	05011659	Gudgeon M6 x 25
7	4	05011215	Nut Tensilok M6 Zn
8	1	05021058	Hydraulic Motor 10cc
9	2	05006578	Angle MJ 3/4 - MG 1/2 Cyl. With Counter Nut
	1	05021128	Seal Kit

### 3 CUTTING ELEMENTS

#### 3.7 BLADE ASSEMBLY LONG LH - CODE 0105 0129

PL 3543

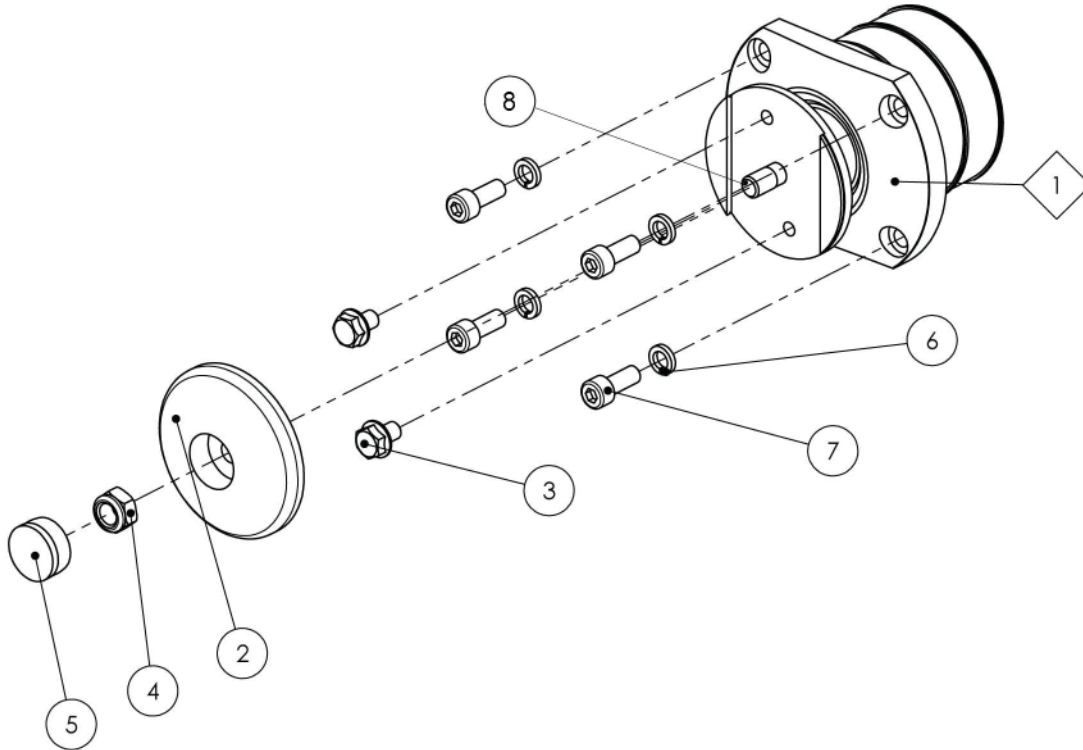

<u>REF #</u>	<u>QTY.</u>	<u>PART NO.</u>	<u>DESCRIPTION</u>	<u>ASSY.</u>
1	1	01050071	Blade Hsg. Assy. Long LH	PL 3558 - Pg 27
2	1	01050031	Cup	
3	2	05011861	Screw Tensilok M8 x 12 Zn	
4	1	05014311	Locknut M10	
5	1	05017926	Cap Ø26 mm	
6	4	05015317	Washer W8	
7	4	05010902	Screw CHC M8 x 20	
8	1	05011664	Stud M10 x 30	



### 3 CUTTING ELEMENTS

#### 3.8 BLADE ASSEMBLY LONG RH - CODE 0105 0130

PL 3540

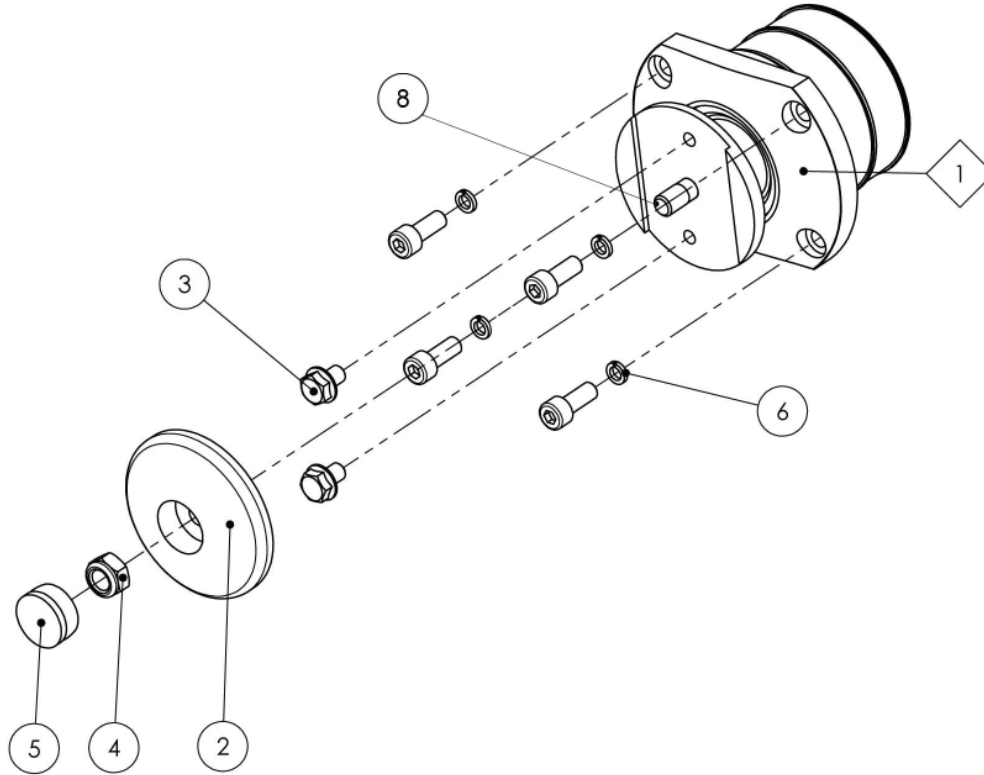

<u>REF #</u>	<u>QTY.</u>	<u>PART NO.</u>	<u>DESCRIPTION</u>	<u>ASSY.</u>
1	1	01050072	Blade Hsg. Assy. Long RH	PL 3556 - Pg 26
2	1	01050031	Cup	
3	2	05011861	Screw Tensilok M8 x 12 Zn	
4	1	05014311	Locknut M10	
5	1	05017926	Cap Ø26 mm	
6	4	05015318	Washer W6	
7	4	05010905	Screw CHC M8 x 20	
8	1	05011664	Stud M10 x 30	

### 3 CUTTING ELEMENTS

#### 3.9 MOTOR BLADE ASSY SHORT RH - CODE 0105 0124

PL 3541

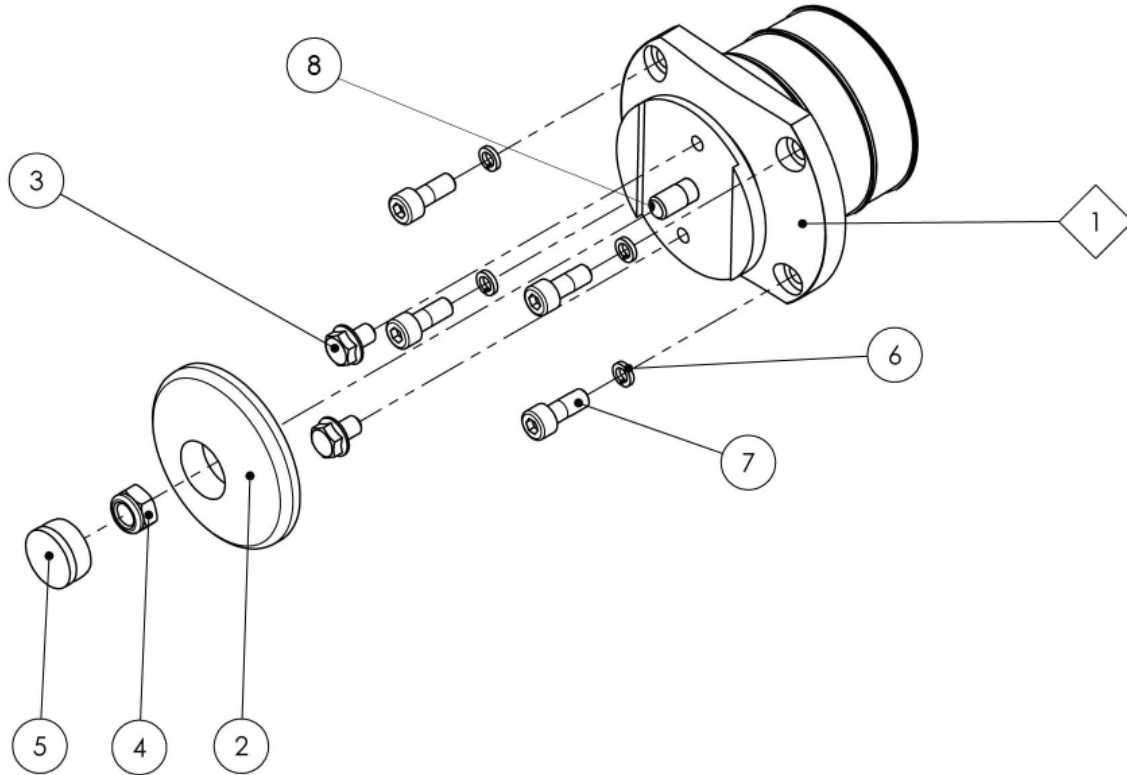

<u>REF #</u>	<u>QTY.</u>	<u>PART NO.</u>	<u>DESCRIPTION</u>	<u>ASSY.</u>
1	1	01050066	Motor Blade Hsg. Assy. Short RH	PL 3557 - Pg 28
2	1	01050031	Cup	
3	2	05011861	Screw Tensilok M8 x 12 Zn	
4	1	05014311	Locknut M10	
5	1	05017926	Cap Ø26 mm	
6	4	05015318	Washer W6	
7	4	05010902	Screw CHC M8 x 20	
8	1	05011664	Stud M10 x 30	

### 3 CUTTING ELEMENTS

#### 3.10 MOTOR BLADE ASSY SHORT LH - CODE 0105 0123

PL 3555

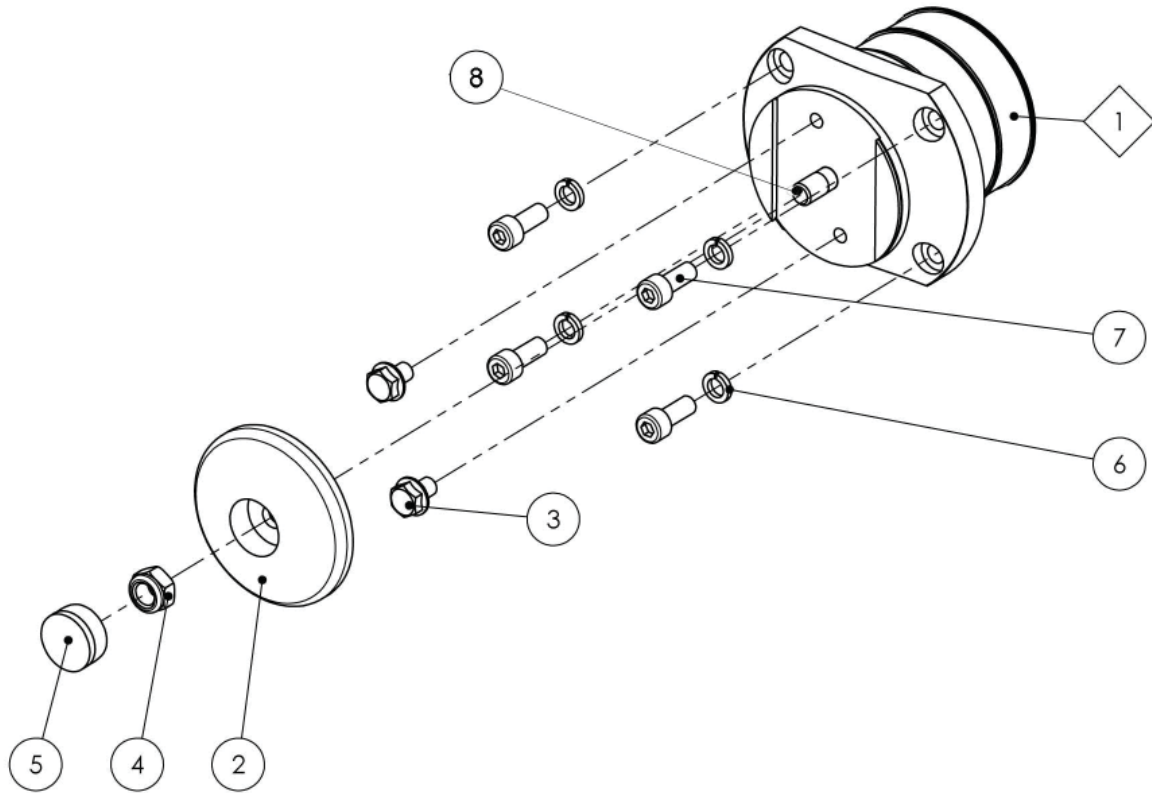

<u>REF #</u>	<u>QTY.</u>	<u>PART NO.</u>	<u>DESCRIPTION</u>	<u>ASSY.</u>
1	1	01050065	Motor Blade Hsg. Assy. Short LH	PL 3559 - Pg 29
2	1	01050031	Cup	
3	2	05011861	Screw Tensilok M8 x 12 Zn	
4	1	05014311	Locknut M10	
5	1	05017926	Cap Ø26 mm	
6	4	05015317	Washer W8	
7	4	05010902	Screw CHC M8 x 20	
8	1	05011664	Stud M10 x 30	

### 3 CUTTING ELEMENTS

#### 3.11 BLADE HSG. ASSY. LONG RH - CODE 0105 0072

PL 3556

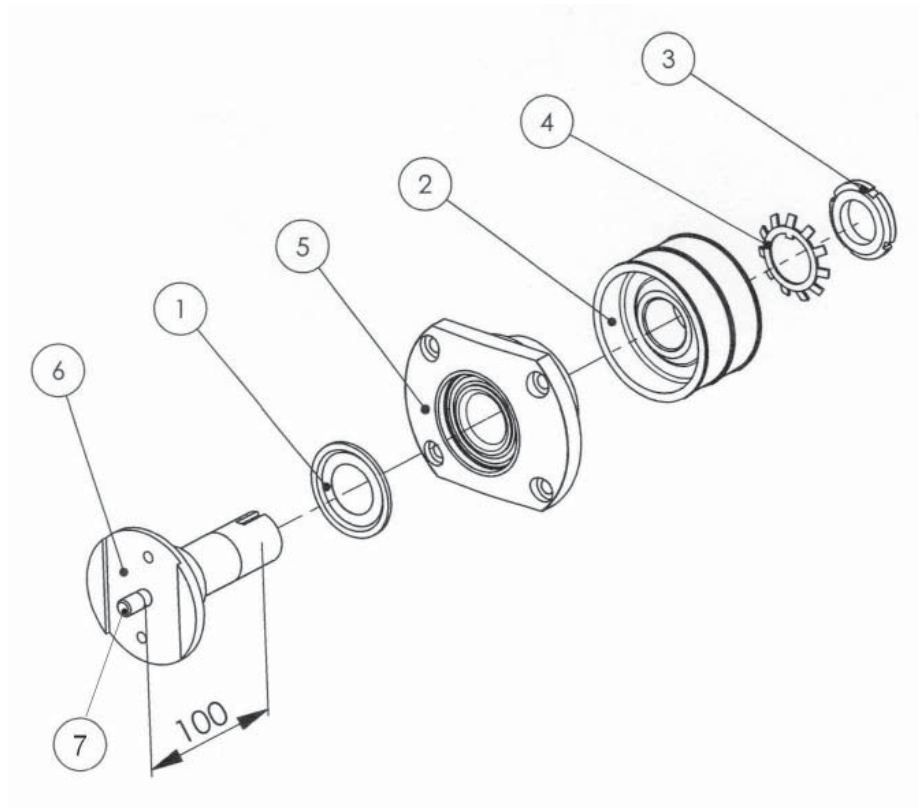

<u>REF #</u>	<u>QTY.</u>	<u>PART NO.</u>	<u>DESCRIPTION</u>	<u>ASSY.</u>
1	1	05000038	Ring NILOS	
2	1	01050025	Pulley	
3	1	05005206	Nut KM6	
4	1	05005256	Washer MB6	
5	1	01050064	Blade Housing	
6	1	01050062	Long Shaft Blade RH	
7	1	05011664	Stud M10 x 30	

### 3 CUTTING ELEMENTS

#### 3.12 BLADE HSG. ASSY. LONG LH - CODE 0105 0071

PL 3558

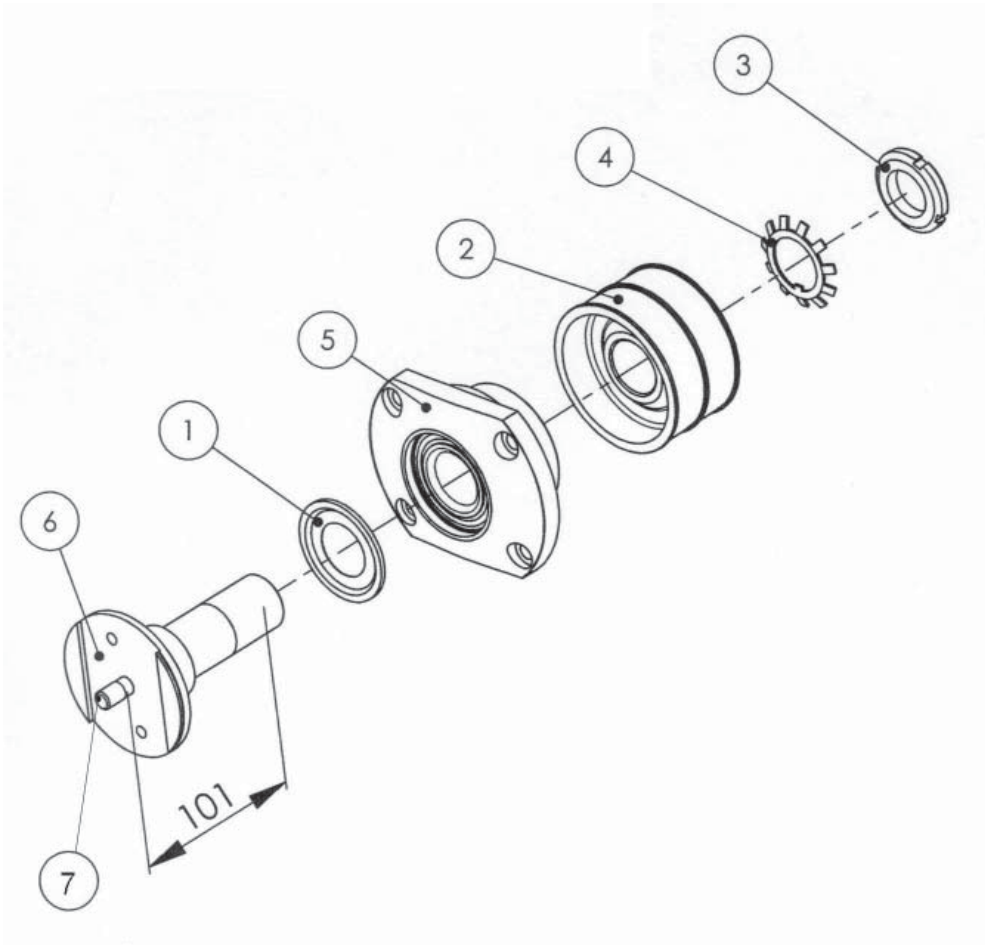

<u>REF #</u>	<u>QTY.</u>	<u>PART NO.</u>	<u>DESCRIPTION</u>	<u>ASSY.</u>
1	1	05000038	Ring NILOS	
2	1	01050025	Pulley	
3	1	05005206	Nut KM6	
4	1	05005256	Washer MB6	
5	1	01050064	Blade Housing	
6	1	01050061	Long Shaft Blade LH	
7	1	05011664	Stud M10 x 30	

### 3 CUTTING ELEMENTS

#### 3.13 MOTOR BLADE HSG. ASSY SHORT RH - CODE 0105 0068

PL 3557

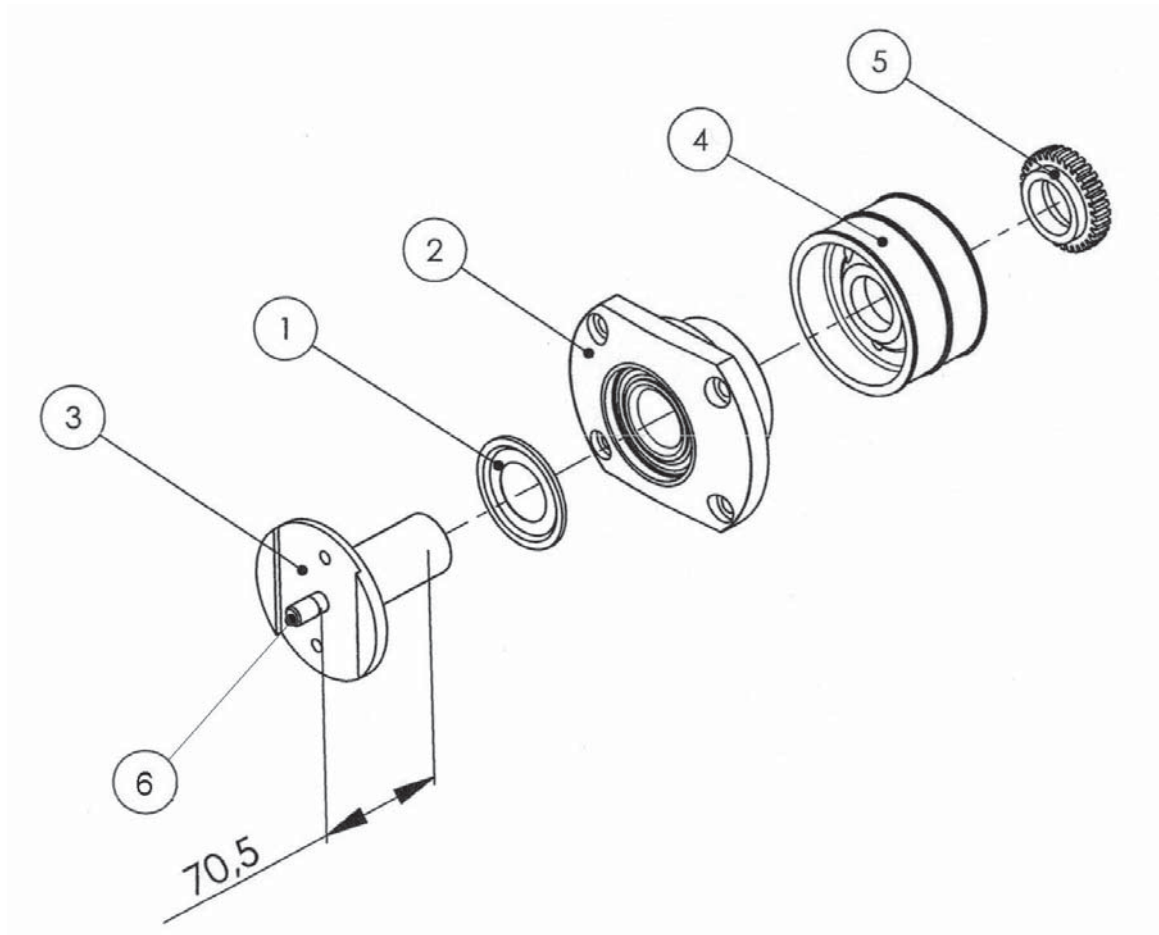

<u>REF #</u>	<u>QTY.</u>	<u>PART NO.</u>	<u>DESCRIPTION</u>	<u>ASSY.</u>
1	1	05000038	Ring NILOS	
2	1	01050064	Blade Housing	
3	1	01050056	Short Shaft Motor, Blade RH	
4	1	01050023	Motor Pulley	
5	1	01050022	Threaded Nut On Right	
6	1	05011664	Stud M10 x 30	

### 3 CUTTING ELEMENTS

#### 3.14 MOTOR BLADE HSG. ASSY SHORT LH - CODE 0105 0065

PL 3559

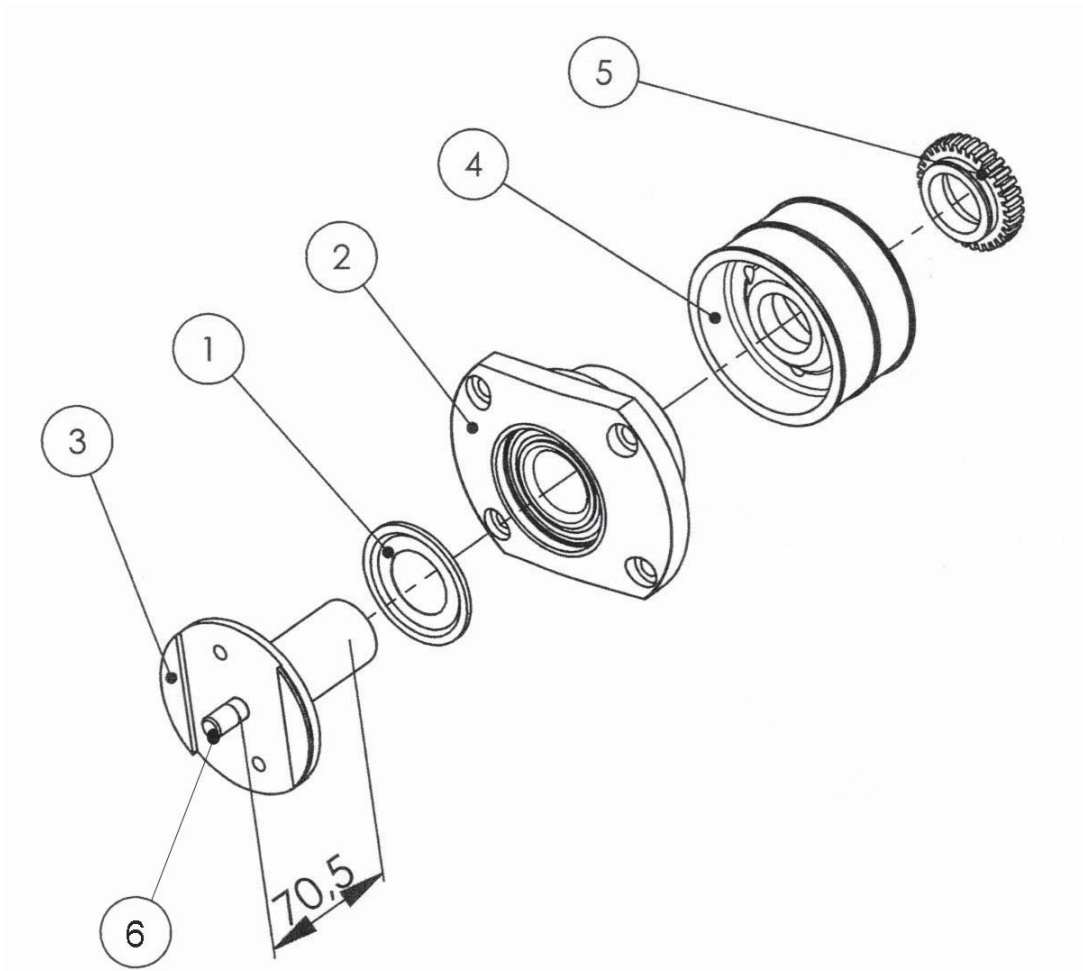

<u>REF #</u>	<u>QTY.</u>	<u>PART NO.</u>	<u>DESCRIPTION</u>	<u>ASSY.</u>
1	1	05000038	Ring NILOS	
2	1	01050064	Blade Housing	
3	1	01050055	Short Shaft Motor, Blade LH	
4	1	01050044	Motor Pulley	
5	1	01050063	Threaded Nut On Left	
6	1	05011664	Stud M10 x 30	

## 4 HYDRAULIC PARTS

### 4.1 DOUBLE EFFECT CYLINDER 60 - 25 - CODE 0501 9751

PL 2316

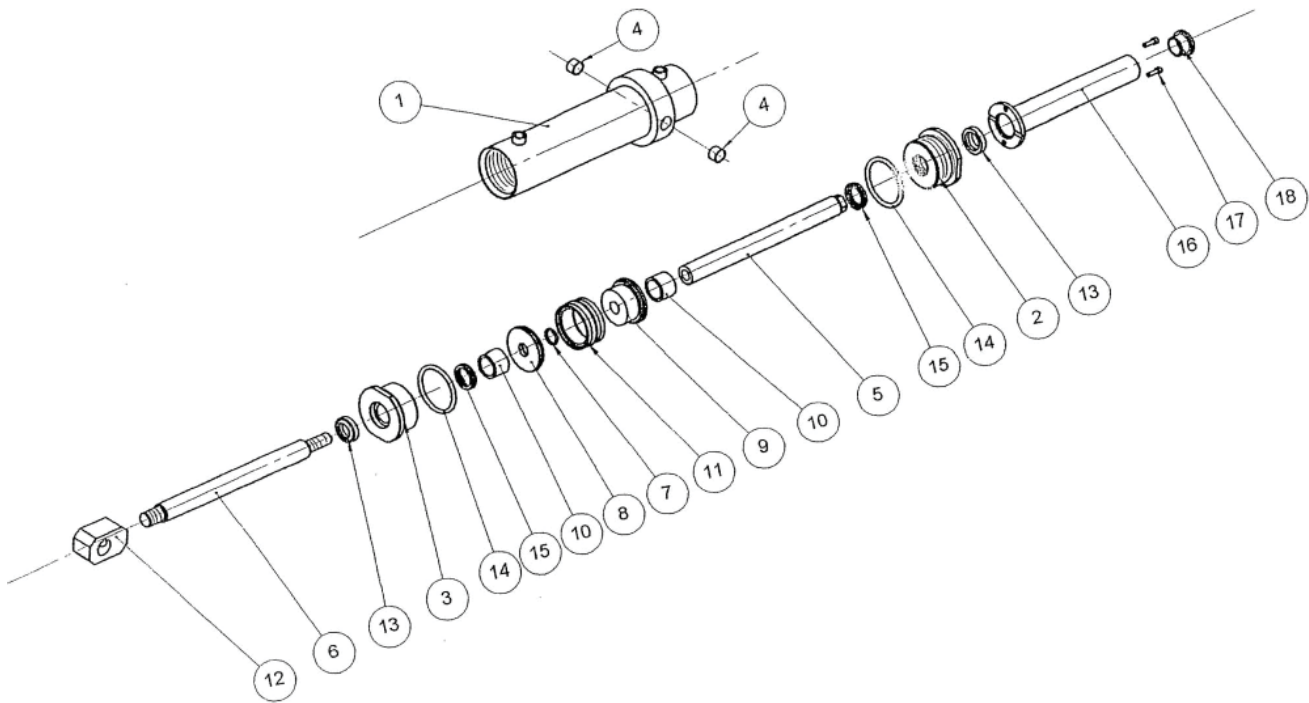

<u>REF #</u>	<u>QTY.</u>	<u>PART NO.</u>	<u>DESCRIPTION</u>
1	1	0501 9752	Cylinder Body
2	1	0501 9775	Threaded Base
3	1	0501 9709	Threaded Base
4	2	0500 5335	Ring
5	1	0501 9754	Secondary Rod
6	1	0501 9753	Main Rod
7	1	0500 1332	Joint
8	1	0501 9712	Round
9	1	0501 9755	Round
10	2	0500 5380	Tube
11	1	0500 0044	Piston Joint
12	1	0501 9707	Fork
13	2	0500 1004	Joint
14	2	0500 1325	Joint
15	2	0500 0042	Joint
16	1	0073 0217	Rod Plug Terminal
17	2	0501 0978	Screw
18	1	0501 7923	Cap



## 4 HYDRAULIC PARTS

### 4.2 CYLINDER DE 35 - 25

PL 2317

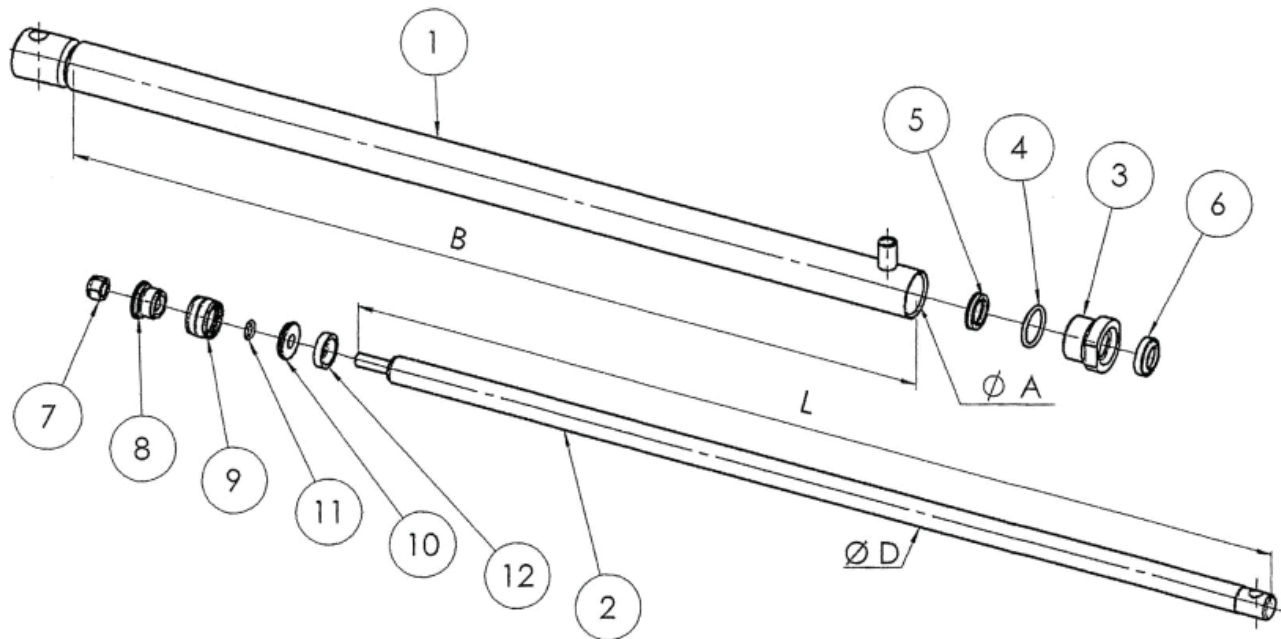

<u>REF #</u>	<u>QTY.</u>	<u>PART NO.</u>	<u>DESCRIPTION</u>
1	1	Corps-body D35 v2	Body (See Table)
2	1	Tige-Rod D25 v1	Rod (See Table)
3	1	05019117	Threaded Base
4	1	05001307	O-Ring
5	1	05000042	Joint
6	1	05001004	Joint
7	1	05014300	Brake Nut M12
8	1	05019670	Half Piston
9	1	05000041	Piston Joint
10	1	05019671	Flask
11	1	05001301	O-Ring R 10
12	1	05005319	Flange

Dimensions in mm:

Cylinder:	Rod:	Body:	ØA	B	L	ØD	Stroke:
0501 9776	0501 9248	0501 9777	45	874	945	25	800

- Set of Seals: 0501 9679

## 4 HYDRAULIC PARTS

### 4.3 HYDRAULIC UNIT - CODE 0502 2916

PL 3878

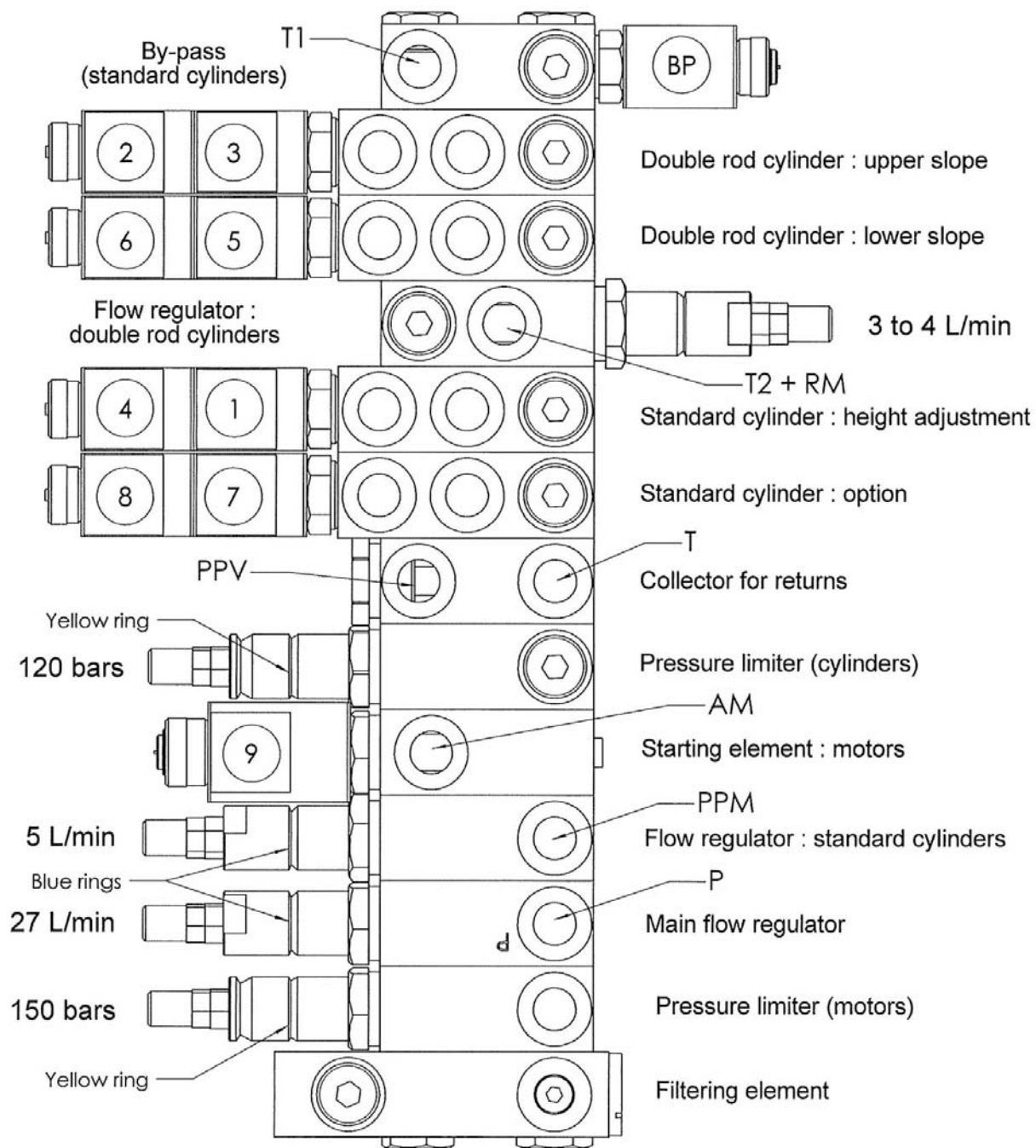

PPV : Cylinders pressure taker  
 PPM : Motors pressure taker  
 AM : Motors feeding flow  
 P : General feeding flow (from the Pump)

T1 : Return 1  
 T2 + RM : Return 2 + Motors return  
 T : General return (to the Tank)

# 4 HYDRAULIC PARTS

## 4.4 ELECTRIC CONTROL HANDLE WITH CROSS LEVER - CODE 0000 2404

*For machines equipped with 1 to 5 double effect cylinders, without function of control for proportional valve*

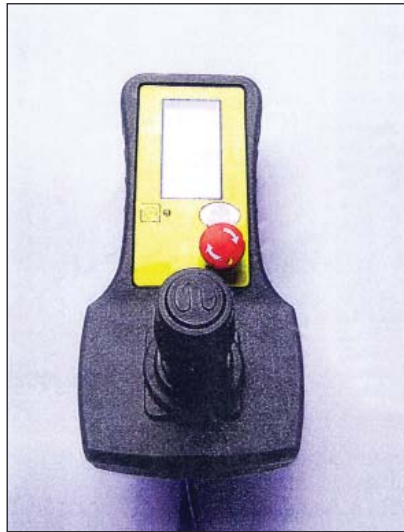

**Complete Electric Control Handle With Box, Wires and Female Plug:**

**0506 0051**

**Bundle of Wires and Male Plug (13 Connectors):**

**0506 1051**

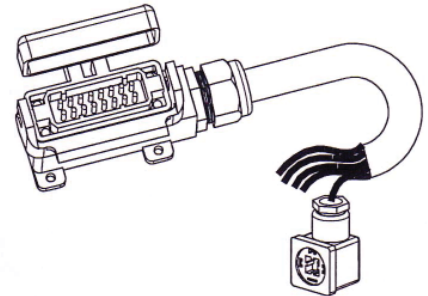
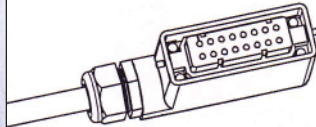

- 1 - 05048509 Red Stop Button, Only
- 1 - 05048507 Joystick Controls & Handle

**Support:**

**0502 9872**

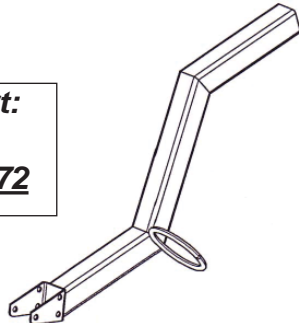

**Connectors 1 to 8, 12 and 13:**  
Double effect cylinder functions

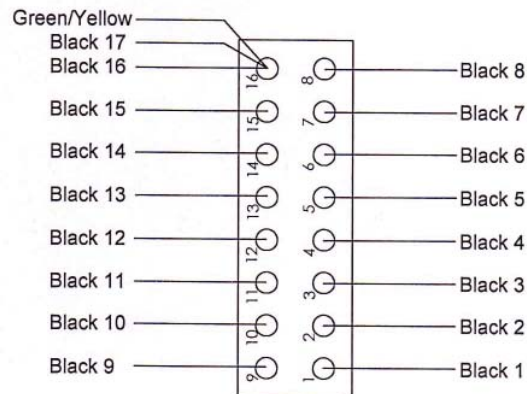

Female plug

**Connector 9:**  
ON/OFF Motors Function

**Connector 10:**  
By-pass Function

**Connector 11:**  
EVC Function (only in case of closed center hydraulic systems which work with the additional hydraulic unit - 0000 1561)

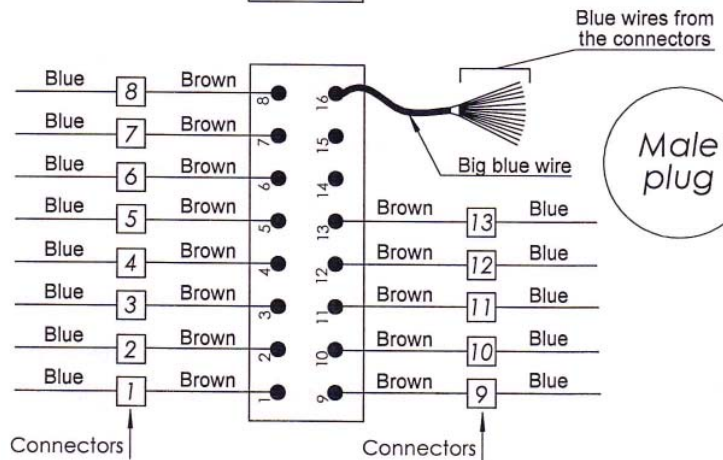

Male plug