

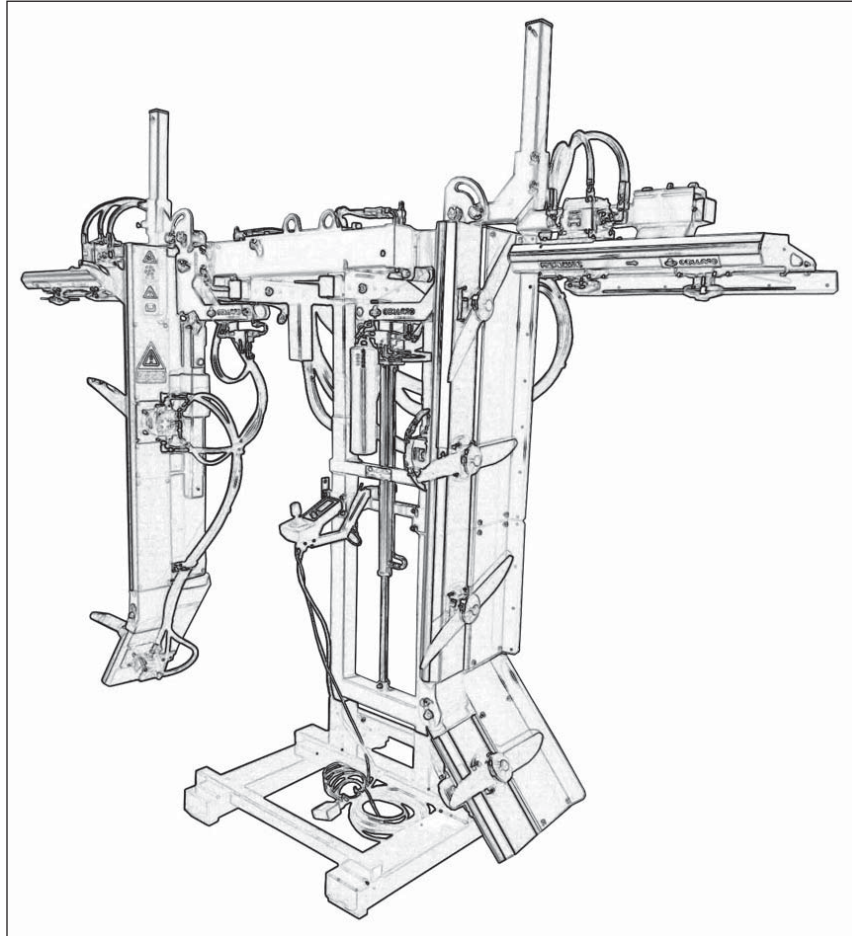

**COLLARD®**

# VINE TRIMMERS



## Installation, Operation & Service Manual For All P2200 Series

*Marketed by:*



13477 Benson Ave. • Chino, CA • Ph: 909/548-4848 • Fax: 909/548-4747

# TABLE OF CONTENTS

<b>SECTION</b>	<b>DESCRIPTION</b>	<b>PAGE</b>
<b>1</b>	<b>Introduction</b>	<b>1</b>
1.1	Operator's Responsibility	1
1.2	Conditions for Use	2
<b>2</b>	<b>Safety</b>	<b>3 - 8</b>
2.1	General Safety	4
2.2	Equipment Safety Guidelines	5
2.3	Safety Training	6
2.4	Safety Signs	6
2.5	Preparation	7
2.6	Operational Safety	8
2.7	General Safety Recap (English)	9-10
2.8	Maintenance Safety (English)	11
2.9	Operating Safety (English)	12
<b>3</b>	<b>Safety Instructions (Spanish)</b>	<b>13 - 16</b>
3.1	General Safety (Spanish)	13-14
3.2	Maintenance Safety (Spanish)	15
3.3	Operating Safety (Spanish)	16
<b>4</b>	<b>Assembly</b>	<b>17 - 22</b>
4.1	Mounting Trimmer to Tractor	17
4.2	Final Assembly	18
4.3	Installation of Blade Protections	19
4.4	Setting Up	20-21
4.5	Handling	22
<b>5</b>	<b>Troubleshooting</b>	<b>23</b>
<b>6</b>	<b>Adjustments</b>	<b>24 - 26</b>
6.1	Adjustment of Inclination of Arms	24
6.2	Adjustment of Play in Tubes	24
6.3	Adjustment Speed of Cylinder Rod	24
6.4	Adjustment of Mechanical Parts	25-26
<b>7</b>	<b>Hydraulic System</b>	<b>27 - 30</b>
7.1	P2200 Standard Electric Control	28
7.2	Electric Control Handle	29
7.3	Electric Control Ref. 000 2404	30
<b>8</b>	<b>Maintenance</b>	<b>31 - 34</b>
8.1	Annual & Periodic Maintenance	31
8.2	Replacement of Blades	32
8.3	Assembly of Plastic Cap	33
8.4	Replacement of Belts	34

# 1 INTRODUCTION

Congratulations on your selection of a Collard Vine Trimmer.

## **HISTORY**

The COLLARD family has been servicing grape growers for 5 generations. Andre Collard invented the first mechanical vine trimmer in 1962. Since that development COLLARD has made numerous improvements and continues to be the world leader in trimmers.

## **QUALITY CONTROL**

Every stage in the production process is controlled to guarantee superior quality. After final assembly, each machine is run through a detailed test where everything is checked - rotation speed, operating pressure, hydraulic cylinders, flow rates, etc. All this is done to insure that every machine leaving the factory is in perfect working order.



## 1.1 OPERATOR'S RESPONSIBILITY

Safe, efficient and trouble free operation of your Vine Trimmer requires that you and anyone else who will be operating or maintaining the machine, read and understand the Safety, Installation, Operation, Maintenance, and Troubleshooting information contained within the Operator's Manual.

Keep this manual handy for frequent reference and to pass on to new operators or owners. Call your tractor dealer if you need assistance, information or additional copies of the manuals.

**OPERATOR ORIENTATION** - The directions left, right, front and rear, as mentioned throughout this manual, are as seen from the driver's seat and facing in the direction of travel.

NAME: \_\_\_\_\_

PURCHASED FROM: \_\_\_\_\_

DATE OF PURCHASE: \_\_\_\_\_

CODE NUMBER: \_\_\_\_\_

SERIAL NUMBER: \_\_\_\_\_

---

## 1.2 CONDITIONS FOR USE

### **MACHINE USE** -

This machine is intended exclusively to trim excess vegetation in vineyards. Any other use is not acceptable for this product and is prohibited.



### **QUALIFICATION OF THE OPERATOR:**

The machine ***must*** be used, maintained and repaired only by people who know the procedures and safety requirements.

### **RESPONSIBILITY OF THE MANUFACTURER AND THE USER** -

Follow closely the regulations of installation, operation, adjustment, maintenance and repair contained in this manual.

Use exclusively original Collard spare parts and accessories in conformity according to the recommendations of the manufacturer.

Any modification of the machine and its accessories (mechanics, electric or hydraulics) made by yourself or by another person not authorized, can make your machine dangerous.

In the event of damage or injuries, the responsibility of the Collard company will be entirely released.

# SAFETY ALERT SYMBOL

This Safety Alert symbol means **ATTENTION! BECOME ALERT! YOUR SAFETY IS INVOLVED!**



The Safety Alert symbol identifies important safety messages on the trimmer and in the manual. When you see this symbol, be alert to the possibility of personal injury or death. Follow the instructions in the safety message.

Why is SAFETY important to you?

### 3 Big Reasons

**Accidents Disable and Kill**  
**Accidents Cost**  
**Accidents Can Be Avoided**

### SIGNAL WORDS:

Note the use of the signal words **DANGER**, **WARNING** and **CAUTION** with the safety messages. The appropriate signal word for each message has been selected using the following guide-lines:

**SI NO LEE INGLES, PIDA AYUDA A AIGUIEN QUE SI LO LEA PARA QUE LE TRADUZCA LAS MIDIDAS DE SEGURIDAD.**

**DANGER** - Indicates an imminently hazardous situation that, if not avoided, will result in death or serious injury. This signal word is to be limited to the most extreme situations typically for machine components which, for functional purposes, cannot be guarded.

**WARNING** -Indicates a potentially hazardous situation that, if not avoided, could result in death or serious injury, and includes hazards that are exposed when guards are removed. It may also be used to alert against unsafe practices.

**CAUTION** -Indicates a potentially hazardous situation that, if not avoided, may result in minor or moderate injury. It may also be used to alert against unsafe practices.

If you have any questions not answered in this manual or require additional copies or the manual is damaged, please contact your dealer.

## 2.1 GENERAL SAFETY

**YOU** are responsible for the **SAFE** operation and maintenance of your implement. **YOU** must ensure that you and anyone else who is going to operate, maintain or work around the trimmer be familiar with the operating and maintenance procedures and related **SAFETY** information contained in this manual. This manual will take you step-by-step through your working day and alerts you to all good safety practices that should be adhered to while operating the trimmer.

Remember, **YOU** are the key to safety. Good safety practices not only protect you, but also the people around you. Make these practices a working part of your safety program. Be certain that **EVERYONE** operating this equipment is familiar with the recommended operating and maintenance procedures and follows all the safety precautions. Most accidents can be prevented. Do not risk injury or death by ignoring good safety practices.

- Trimmer owners must give operating instructions to operators or employees before allowing them to operate the machine, and at least annually there after per OSHA (Occupational Safety and Health Administration) regulation 1928.57.
- The most important safety feature on this equipment is a **SAFE** operator. It is the operator's responsibility to read and understand **ALL** Safety and Operating instructions in the manual and to follow these. Most accidents can be avoided.
- A person who has not read and understood all operating and safety instructions is not qualified to operate the machine. An untrained operator exposes himself and bystanders to possible serious injury or death.
- **DO NOT** modify the equipment in any way. Unauthorized modification may impair the function and/or safety and could affect the life of the equipment.
- **Think SAFETY! Work SAFELY!**

1. Read and understand the Operator's Manual and all safety signs before operating, maintaining, or adjusting the trimmer.



2. Have a first-aid kit available for use should the need arise and know how to use it.



3. Have a fire extinguisher available for use should the need arise and know how to use it.



4. Wear appropriate protective gear. This list includes but is not limited to:

- A hard hat
- Protective shoes with slip resistant soles
- Protective goggles, glasses or face shield
- Heavy gloves
- Protective clothing

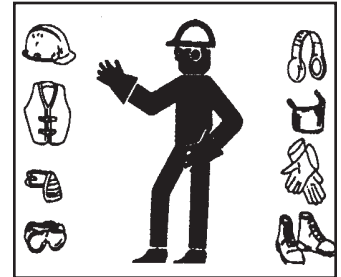

5. **DO NOT** allow riders.



6. Wear suitable ear protection for prolonged exposure to excessive noise.

7. Place all controls in neutral, stop tractor engine, set park brake, remove ignition key and wait for all moving parts to stop before servicing, adjusting, repairing, or unplugging.

8. Clear the area of people, especially small children, before starting.

9. Review safety related items annually with all personnel who will be operating or maintaining the trimmer.

## 2.2 EQUIPMENT SAFETY GUIDELINES

Safety of the operator and bystanders is one of the main concerns in designing and developing a trimmer. However, every year many accidents occur which could have been avoided by a few seconds of thought and a more careful approach to handling equipment. You, the operator, can avoid many accidents by observing the following precautions in this section. To avoid personal injury or death, study the following precautions and insist those working with you, or for you, follow them. If potentially dangerous situations are known, accidents can be prevented!

- The vine trimmer, as described in this instruction and maintenance booklet, has been specifically designed for trimming excess vegetation in vineyards. Any other use jeopardizes the operator's safety and the machine integrity.

In each of the following (3) three situations, the cutting blade rotation ***must be turned off***.

1. Before starting the tractor.
  2. When transporting the tractor/trimmer.
  3. Whenever the driver exits the tractor.
- **Under no circumstances should young children be allowed to work with this equipment. Do not allow persons to operate or assemble this unit until they have read this manual and have developed a thorough understanding of the safety precautions and of how it works. Review the safety instructions with all users annually.**
  - Do not modify the equipment in any way. Unauthorized modification may impair the function and/or safety and could affect the life of the equipment.

Only operate this trimmer on a properly sized and equipped tractor.

Before doing any cleaning, adjusting, repairing or maintenance operation on the trimmer:



- Turn off the tractor engine.
- Lower all cylinders to the base of their stroke, so that the trimmer is in the lowest position.
- All the removable protection devices must be in place, except when working on the blades.

**If the tractor does not have a cab, protective glasses must be worn at all times.**

Before use, make sure all bolts and nuts are tightened, particularly on the brackets between the trimmer and tractor.

When putting the blades in motion and at all times during operations, nobody except the tractor operator should be in the area.

When leaving vineyard rows turn off the cutting mechanism.

After each use, the protection guard must be replaced to the front side of the blades. The guard must also be in place when transporting the tractor/trimmer. No fixed protection part may be modified or removed from the machine.

When handling the trimmer you must use the lifting rings which are provided for that purpose.

As soon as any abnormal vibration is felt, stop and inspect the motor or have your dealer inspect until the cause has been identified.

When working on the cutting blades requiring their removal or cleaning, be sure to wear leather gloves, to avoid injury in case of contact with the blade cutting edges. The blades have been balanced at the factory. Normal use should not affect the cutting edge. Any blade which receives an impact, becomes deformed or marked must be replaced. **DO NOT TRY TO REPAIR THE BLADE.** Each time the blades are removed, the NYLSTOP nuts must be replaced with new ones.

The hydraulic components are set and tested at the factory. Your dealer should be contacted if adjustments are required.

**IMPORTANT:** The identification plate, bearing the equipment type and serial number must never be removed from the trimmer.

Nobody is authorized to **ever** be in the area when the trimmer is in operation, except the operator, who **must never** leave the tractor when the blades are moving.

**Never**, for any reason, should you clean or remove vegetation when the trimmer is operating.



## 2.3 SAFETY TRAINING

Safety is a primary concern in the design and manufacture of our products. Unfortunately, our efforts to provide safe equipment can be wiped out by a single careless act of an operator or bystander.

In addition to the design and configuration of equipment, hazard control and accident prevention are dependent upon the awareness, concern, prudence and proper training of personnel involved in the operation, transport, maintenance and storage of this equipment.

It has been said, "***The best safety feature is an informed, careful operator.***" We ask you to be that kind of an operator. It is the operator's responsibility to read and understand ALL Safety and Operating instructions in the manual and to follow these. Accidents can be avoided.



Working with unfamiliar equipment can lead to careless injuries. Read this manual, and the manual for your tractor, before assembly or operating, to acquaint yourself with the machines. If this machine is used by any person other than yourself, or is loaned or rented, it is the machine owner's responsibility to make certain that the operator, prior to operating:

- a. Reads and understands the operator's manuals.
- b. Is instructed in safe and proper use.

Should ownership of the equipment be transferred, this manual must also be transferred.

Know your controls and how to stop tractor, engine and machine quickly in an emergency. Read this manual and the one provided with your tractor.

Train all new personnel and review instructions frequently with existing workers. Be certain only a properly trained and physically able person will operate the machinery. A person who has not read and understood all operating and safety instructions is not qualified to operate the machine. An untrained operator exposes himself and bystanders to possible serious injury or death. If the elderly are assisting with farm work, their physical limitations need to be recognized and accommodated.

For any part of this manual that you do not understand, contact your dealer.

## 2.4 SAFETY SIGNS

1. Safety decals and this manual must be considered a permanent part of your equipment.
2. Keep safety signs clean and legible at all times.
3. Replace safety signs that are missing or have become illegible.
4. Replaced parts that displayed a safety sign should also display the current sign.
5. Safety signs are available from your authorized dealer.

### How To Install Safety Signs:

- Be sure that the installation area is clean and dry.
- Be sure temperature is above 50° F (10° C).
- Determine exact position before you remove the backing paper.
- Remove the smallest portion of the split backing paper.
- Align the sign over the specified area and carefully press the small portion with the exposed sticky backing in place.
- Slowly peel back the remaining paper and carefully smooth the remaining portion of the sign in place.
- Small air pockets can be pierced with a pin and smoothed out using the piece of sign backing paper.



## 2.5 PREPARATION

1. Never operate the tractor and trimmer until you have read and completely understand this manual, the Tractor Operator's Manual and each of the Safety Messages found on the safety signs on the tractor and trimmer.

2. Personal protection equipment, including hard hat, safety glasses, safety shoes and gloves are recommended during assembly, installation, operation, adjustment, maintaining, repairing, removal or moving the implement. **DO NOT** allow long hair, loose fitting clothing or jewelry to be around equipment.

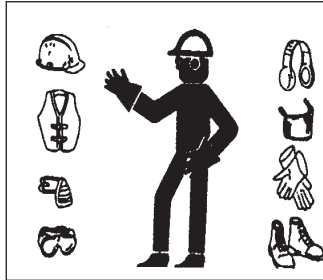

3. **PROLONGED EXPOSURE TO LOUD NOISE MAY CAUSE PERMANENT HEARING LOSS!**

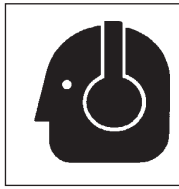

Tractors with or without equipment attached can often be noisy enough to cause permanent, partial hearing loss. We recommend that you wear hearing protection on a full-time basis if the noise in the Operator's position exceeds 80db. Noise over 85db on a long-term basis can cause severe hearing loss. Noise over 90db adjacent to the Operator over a long-term basis may cause permanent, total hearing loss.

**NOTE:** Hearing loss from loud noise (from tractors, chain saws, radios, and other such sources close to the ear) is cumulative over a lifetime without hope of natural recovery.

4. Always consider the features of the area where work is taking place. When the equipment is running, it is forbidden to stand within the field of action of the trimmer.
5. Before and while working, do not drink alcohol, take drugs, or any other substances which may alter your capability of working with machine tools.
6. Do not use the trimmer under unsafe conditions. For instance, it is forbidden to execute makeshift repair activities just to start working. Operate only in daylight or good artificial light.
7. Be sure to have sufficient fuel, to prevent a forced stopping of the trimmer, maybe during a critical movement.
8. Ensure that all safety shielding and safety signs are properly installed and in good condition.
9. Never operate the trimmer without all shields in place and in good operational condition.
10. The operator must be familiar with the trimmer and tractor and all associated safety practices before operating the trimmer and tractor.

## 2.6 OPERATIONAL SAFETY

### WHEN WORKING OR DURING THE MAINTENANCE ACTIVITIES IT IS NECESSARY TO REMEMBER:

The use of this equipment is subject to certain hazards that cannot be protected against by the mechanical means or product design. All operators of this equipment must read and understand this entire manual, paying particular attention to safety and operating instructions, prior to using. If there is something in this manual you do not understand, ask your supervisor, or your dealer, to explain it to you.

Most accidents occur because of neglect or carelessness. Keep all helpers and bystanders at least several hundred feet from an operating trimmer. Only properly trained people should operate this machine. ***Operation must be stopped when anyone comes within several hundred feet.***

The labels and stickers providing instructions and pointing out the dangers, must not be removed, hidden, or made illegible.

Do not remove, except in case of maintenance, the shields, guards, and deflectors equipped on the trimmer. When it is necessary to remove them, stop engine, handle with care and reassemble them properly before restarting the engine and using the equipment.

All shields, guards, and deflectors equipped on the trimmer must be maintained in good operational condition.

It is forbidden to lubricate, clean and adjust the moving parts while they are running.

During maintenance or adjustment activities on the equipment it is forbidden to use hands for executing operations for which there are specific tools.

Do not use tools in bad condition or inappropriately, for instance pliers rather than wrenches.

When maintenance or repairs are completed check out that no tools, wiping rags, or other materials are left inside spaces or guides with moving parts.

While using the equipment, it is forbidden to make more than one person give directions and make signals. The eventual directions and signals relating to the load handling must be given by one person only.

Do not unexpectedly call an operator while he is working if not necessary; it is forbidden as well to frighten or throw objects at the operator, even if just for fun.

Watch out for those who are present, especially the children! Do not let people get on the machine.

When not in use, stop the vehicle's engine, park it on flat ground with parking brake engaged and the PTO disengaged. Never leave equipment unattended with the tractor running.

Do not clean, lubricate, repair or adjust with the engine running and the machine lifted.

Do not allow riders on the trimmer or tractor at any time. There is no safe place for any riders. Do not operate unless all personnel, livestock, and pets are several hundred feet away.

Never use the machine on steep slopes which may jeopardize the equipment's stability.

***The manufacturer declines all responsibility for a lack of compliance with these instructions.***

GENERAL SAFETY INSTRUCTIONS:

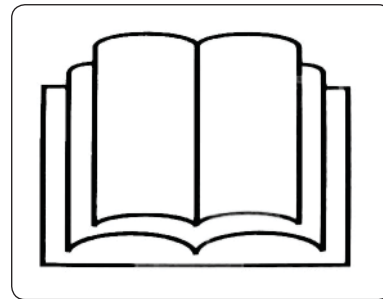

Please carefully read and understand the operating instructions of this manual before using the Vine Trimmer.



**DANGER:** Keep hands, feet and clothes away from all moving parts.



**WARNING:** Only qualified personnel must use this machine. You **MUST** keep children away from this machine even when it is not operating.



**DANGER:** This machine has dangerous moving parts. Keep a safe distance from the tractor and implement.

- Make sure that there is nobody in the neighboring vineyard rows. For safety sake, sound the horn at the beginning of each new row.
- Also, sound the horn before coming to the end of each row.
- When leaving the vineyard rows and making turns to next row - switch off the cutting mechanism.

**IMPORTANT:** *When switching the cutting mechanism back on there will be a 10 to 15 second delay for safety.*

- Notify all field workers and other personnel that this implement will be working in an area and to stay out of that area.
- After each use, the protective snap-on plastic guard must be placed over the blades.
- Fixed protection guards can not be removed from the machine or modified.

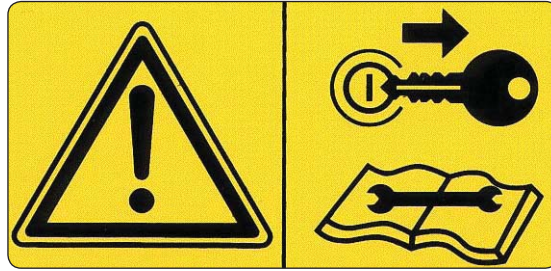

**WARNING:** Before performing any service, verify that both the tractor and machine are firmly on the ground in a stable position. Next, turn off both the tractor and machine - Do Not forget to remove the key from the tractor ignition.

- When doing any work on the blades requiring their removal or cleaning, be sure to wear leather gloves to avoid injury in case of contact with the cutting edges.
- The blades have been balanced at the factory. Normal usage should not affect the cutting edge. Any blade which receives an impact becomes deformed or marked must be replaced.
- The blades are extremely sharp. So always use the supplied COLLARD blade holding tool when working on the blades.

### DO NOT TRY TO REPAIR BLADES!

- Each time the blades are removed, the NYLSTOP nuts must be replaced with new ones.
- The hydraulic components are set at the factory. Only your COLLARD dealer is authorized to make adjustments.

- Before use, you **must** make sure all bolts, nuts and connections are tight. In particular the brackets between the machine and tractor.
- If the tractor does not have a cab, protective glasses **must** be worn at all times.
- Clear the area of people, especially children, before operating the machine.
- There must **never** be anybody on the tractor or machine, except the driver.
- The tractor operator **must** never leave the tractor, until the vine trimmer is stopped, the tractor engine is stopped, and the key is removed.
- Any cleaning or other minor adjustments required must be done by the tractor operator only. Nobody else should be in the area when this work is done.

### 3 INSTRUCCIONES GENERALES DE SEGURIDAD

#### 3.1 INSTRUCCIONES GENERALES DE SEGURIDAD:

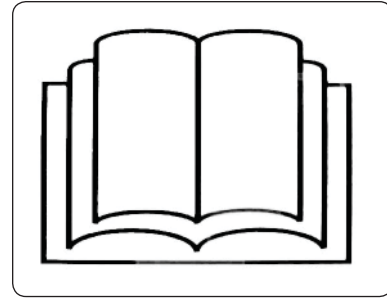

Por favor, lea el manual de instrucciones antes de usar la cortadora para vid de uva.

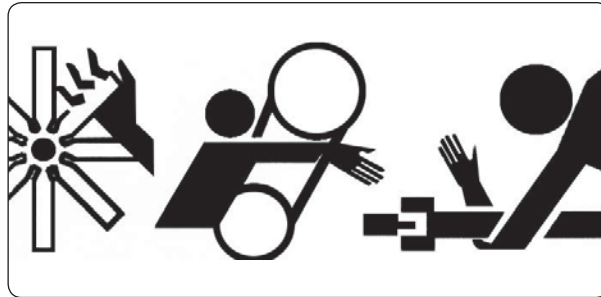

**PELIGROSO:** Mantenga sus manos, pies y ropa alejados de las piezas en movimiento.



**ALARMA:** Sólo el personal calificado debe utilizar esta máquina. Asegúrese de mantener a los niños alejados del alcance de esta máquina, incluso cuando no está funcionando.



## Instrucciones Generales De Seguridad (CONTINUAR)



**PELIGROSO:** Está máquina tiene piezas móviles peligrosas que pueden causar heridas. Mantenga una distancia segura del tractor y la máquina.

- Asegúrese de que no hay nadie cercano a las filas del viñedo. Para mayor seguridad, utilice la bocina al comienzo de cada nueva fila del viñedo.
- Use la bocina para alertar cuando se llega al final de cada fila del viñedo.
- Cuando haya terminado de cortar la fila del viñedo y antes de empezar a cortar la siguiente fila asegúrese de apagar el mecanismo de corte.

**ATENCION:** Cuando quieran prender la maquina de nuevo, sera 10 - 15 segundos de espera antes que prenda de nuevo por seguridad.

- Notifiquen a todos los trabajadores y demás personas que ésta máquina va a trabajar en la zona y que deben permanecer fuera del area.
- Cuando haya terminado con la máquina, asegúrese de que la cubierta protectora se coloque sobre las cuchillas de corte.
- No retire o modifique las guardas de protección estacionarias.

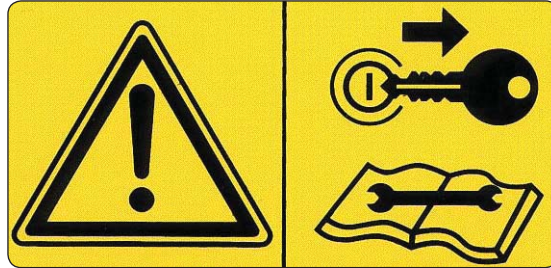

**ALARMA:** Antes de realizar cualquier servicio, verifique que tanto el tractor como la máquina están firmemente en el suelo en una posición estable. A continuación, apague tanto el tractor como la máquina. No se olvide de quitar la llave de ignición del tractor.

- Asegúrese de utilizar guantes de cuero al retirar o limpiar las cuchillas de corte. Esto ayudará a evitar daños por el filo de cuchilla de corte.
- Las cuchillas de corte han sido equilibradas por la Fábrica. El uso normal afectará el borde de la cuchilla de corte. Si la cuchilla recibe un impacto fuerte o se deforma, se debe reemplazar.
- Las cuchillas son muy afiladas. Asegúrese de que utiliza la herramienta de sujeción hoja suministrada por Collard al trabajar con las cuchillas.

### NO REPARE CUCHILLAS!

- Cada vez que las cuchillas de corte se retiran, las tuercas de nyloc deben ser sustituidas por otras nuevas.
- Los componentes hidráulicos se fijan en la fábrica. Sólo su distribuidor Collard está autorizado para hacer cualquier ajuste.

- **Antes de operar la máquina, asegúrese de que todas las tuercas, pernos estén apretados. Observe cuidadosamente el soporte de montaje de la máquina a donde se un al tractor. Asegúrese de que todas las conexiones hidráulicas y eléctricas están seguras.**
- **Es muy importante que las gafas protectoras (lentes protectoras) sean usados en todo momento.**
- **Asegúrese de que No Haya Personas, especialmente niños, en la zona antes de poner a funcionar la máquina de corte.**
- **Nunca debe haber nadie sobre el tractor o máquina, con excepción del conductor.**
- **El conductor del tractor No debe abandonar el tractor hasta que la máquina de corte se detiene completamente, el motor del tractor esta apagado y la llave ha sido quitada.**
- **Cualquier operación de limpieza o de otros pequeños ajustes que se requieran deben ser realizadas por el operador del tractor en el área a donde esta trabajando. Todos los otros ajustes se deben hacer en el taller de servicio.**

## 4 ASSEMBLY

### 4.1 MOUNTING TRIMMERS TO THE TRACTOR

To aid in the front mounting of the Vine Trimmer to your tractor we provide the following items:

- A** - A universal double pocket mounting bracket for the front of the tractor.
- B** - Two back braces with a tubing inside of a tubing assembly. One end attaches to the top mast of the main frame. The other end attaches to the frame of the tractor. After bolting in place, it will require welding the tubing together.
- C** - This storage stand is standard equipment with all P2200 Series Vine Trimmers. This makes for an easy, safety system for storing the unit.

Once the trimmer has been placed to the desired position with the provided universal double pocket bracket (**A**) bolted to the trimmer, clamp this assembly in place per your requirements.

The mounting bracket that must be made is the spacer plate that fits between bracket and the front of the tractor. The thickness of bracket will vary depending on how much clearance is required to safely clear the grill of the tractor.

The back brace rods (**B**) ensure strong stability of the trimmer to the tractor. These rods are bolted to the trimmers brackets as shown (**C**).

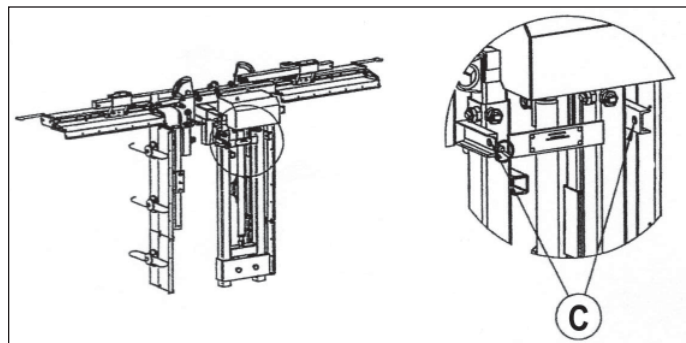
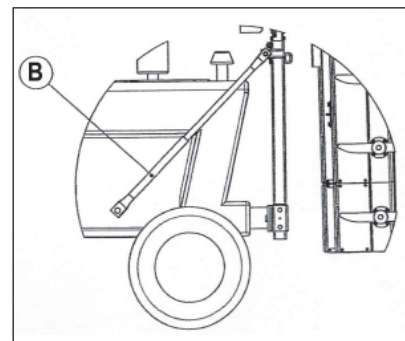
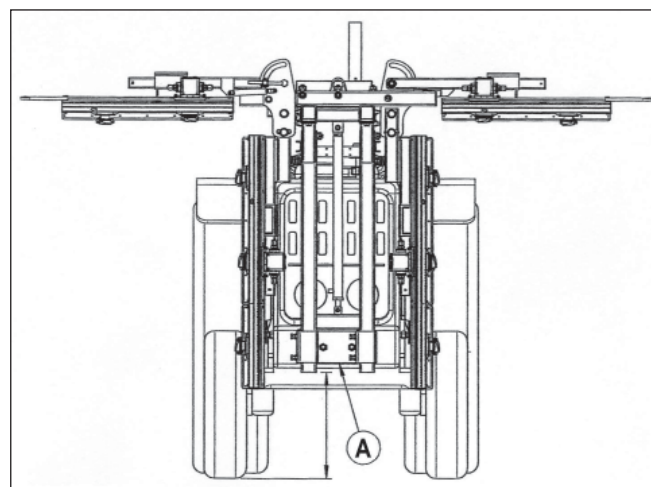
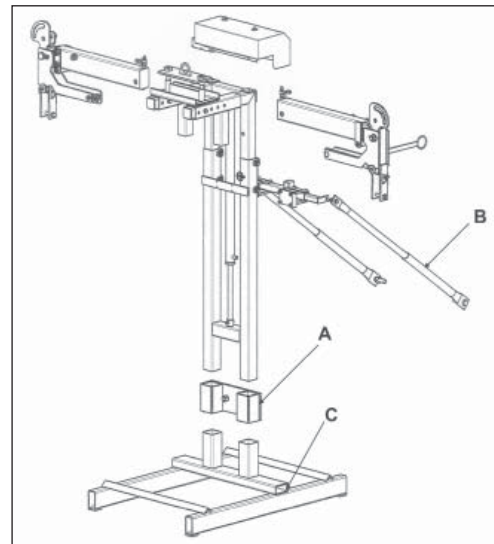

## 4.2 FINAL ASSEMBLY

In order to ensure the correct mounting of the trimmer to the tractor, please follow closely the following instructions:

- Angle (**A**) should be no more than 45 degrees
- Length (**L1**) should be as short as possible
- Distance (**L2**) should be as long as possible
- Height (**H**) should be as high as possible

After bolting the 2 piece back brace rods in place, weld the inner and outer tubes together.

**NOTE:** After assembly, make sure that the tractor/trimmer mounting is strong enough to give years of trouble free service.

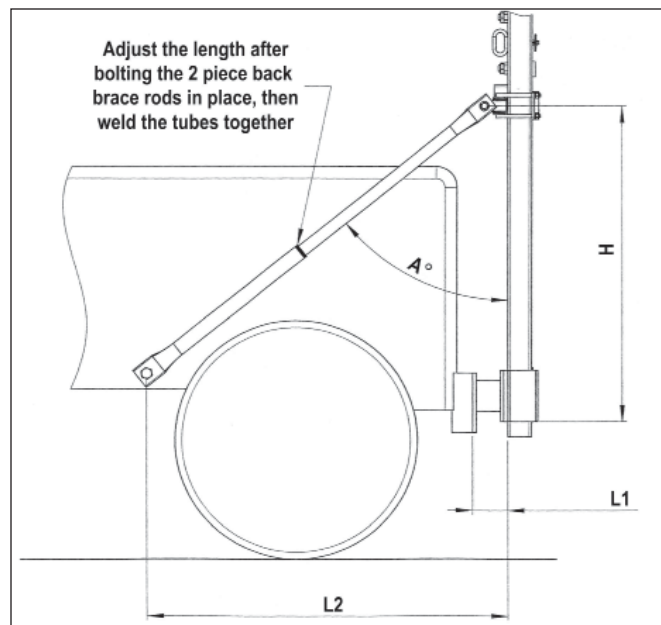

### MOUNTING VINE TRIMMERS TO CRAWLER TRACTORS

Collard does not recommend mounting their Vine Trimmers to crawler tractors due to severe vibrations.

However, if you elect to mount our trimmer to a crawler, please follow closely the following instructions:

1. Daily you should check all hardware for tightness.  
**Note: If bolts come loose it could cause damage to the trimmer and potential safety to the operator.**
2. Make sure to mount an extra strong bracket between the tractor and the vine trimmer, as it must be able to withstand violent forces.
3. Make sure the back braces from the vine trimmer to the crawler have strong anchor points.

## 4.3 INSTALLATION OF THE BLADE PROTECTIONS



Safety guards snap in place over the blades.

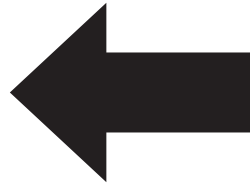
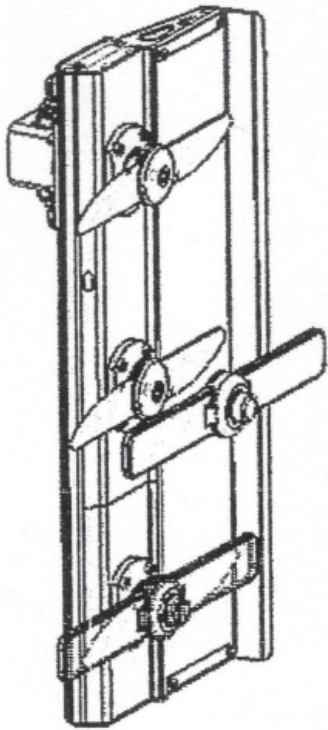

**TO ATTACH:**

Center the blade protection and push to the center

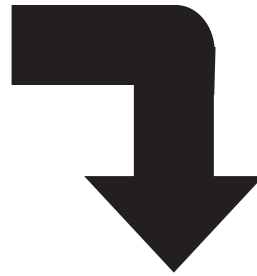

**TO DETACH:**

Make the opposite operation as shown in the illustration

**IMPORTANT** You are required to use blade safety guards.

The blade protections must be positioned on the blades after each trimming, as well as for transport on road or during storage.

It is recommended to wear gloves before any work.

The blade protections must be in good conditions.

**Part Number:** 0503 0600 Plastic Guard

## 4.4 SETTING UP

### 1. Hydraulic Connections

The Vine Trimmers come with 3 hydraulic hoses. Two hoses with JIC male quick couplings plug into the tractor remotes. The third hose is the drain line that should be direct connected to the tractor hydraulic reservoir.

### 2. Mechanical Controls

Make sure, in particular after each adjustment of the cutting elements, that the blades can rotate without meeting obstacles or touching other blades.

The recommended spacing between the horizontal and vertical blades is 1/8" (5 mm).

### 3. Starting

Before starting, it is imperative to read and to take into account the safety instructions.

To insure long life of the cutting blade belts, you must do the following:

- Start the blades approximately 1 hour at 700 to 800 RPM, then 30 minutes at 1000 to 1500 RPM.
- The final operating speed should be approximately 2200 RPM.

### 4. Operation Control

The oil temperature should not exceed 158 degrees (70°C).

In order to get the best output and longest possible years of service from your Collard trimmer, the following operations should be performed prior to using it for the first time.

#### Hydraulic Checks:

Use high quality hydraulic oil recommended by the tractor manufacturer.

Change the oil at least once per year. Make sure that the oil filter is clean. If necessary, depending on the type of oil filter used, clean or change it.

#### **IMPORTANT:**

The high technical complexity of the hydraulic components used on your unit requires that the oil be perfectly clean. **Parts which suffer damage due to a polluted circuit will not be covered by our warranty.**

Carefully check the condition of the pump. It must be able to handle the pressure required by the unit and provide the necessary flow. (See the relevant data sheet).

The oil flow provided by the pump should not be lower than the flow prescribed on the data sheet in order to ensure a minimal speed rotation of the blades, and thus guaranteeing an optimal quality of cut.

**Never exceed the maximum flow of G.P.M. (15.8)** If the maximum flow delivered by the tractor exceeds the maximum acceptable flow by the machine, if this flow is not adjustable and if the pump of the tractor can not control its flow (reduce its cubic capacity under the effect of the pressure), it will be necessary to install a device of regulation imperatively. In case of doubt, contact your dealer.



**If the surplus of flow is not controlled, an overheating of the hydraulic circuit occurs very quickly, then a significant deterioration of the hydraulic system of the tractor and of the machine.**



## 4.4 SETTING UP (CONTINUED)



### EXTREMELY IMPORTANT

The operation of a hydraulic system generally causes pollution due to impurities: loose shavings, paint, silica, sealing paste, rubber, resulting from the dis-assembly and assembly of fittings and components.

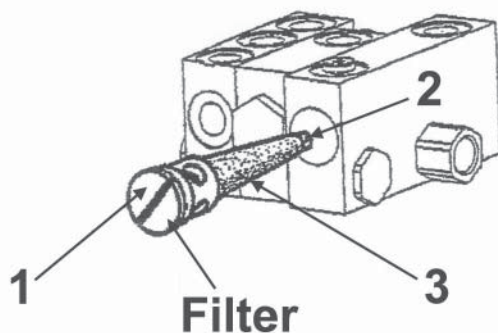

### AT THE FIRST OPERATION

After 1 1/2 hours of operation (corresponding to the running period), it is essential to check the filter and to service it in order to eliminate pollution and to ensure that none remains in suspension.

- › **Prior to dis-assembly:** Clean the hydraulic block and the area surrounding the filter plug to avoid dirt entering the filter during servicing.
- › Using an appropriate screwdriver, remove the filtering cartridge (**Ref. 1**).
- › Remove the nut on the end of the porous element (**Ref. 2**).
- › Remove the filtering element (**Ref. 3**).
- › Soak the filtering element in a container of detergent: gasoline, diesel or benzene for approximately 5 minutes to decompose particles loaded with oil.
- › Blow compressed air through the porous element from the inside to the outside.
- › Dry the filtering element.
- › Re-assemble the filtering element on the plug. Screw the nut on the end of the threaded spindle. Do not force (2.2 ft./pound) or deform the seal between the porous element and the plug.
- › Replace the cartridge in the block.
  - Clamping torque: 3.7 ft./pound

### SUBSEQUENT USE

Check the state of the filter at least once during the trimming season. It is vital that the unit be cleaned before the trimmer is put away (see procedure above).

#### **IMPORTANT:**

In all cases, the filter element must be changed **every 2 years** for a normal use, and **every year** in case of an intensive use.

In the event of damage or deterioration, the filter element will have to be replaced.

## 4.5 HANDLING - TRANSPORT AND STORAGE

The machine is equipped with a support stand used for transport and storage.

### For Transport:

The unit should be moved on a hand pallet truck or a forklift truck. If it is to be lifted using a crane, the trimmer must be suspended by means of the rings provided for this purpose (see data sheet), in order to guarantee that the load is correctly held and balanced at all times. During transit in a vehicle, the unit must be strapped down by the anchoring points.



**During the lifting, stand clear of the machine. The operations of handling must be done by qualified person(s) only.**

The slings must be adapted to the load (see the weight on the technical page) and in good condition. They must be correctly fixed to the rings of lifting or on the principal beam.

### For Storage:

The storage support is only used to stand the Trimmer, and not for the disassembling of the Trimmer from the tractor.

#### **IMPORTANT:**

Before each handling, it is imperative to lock the principal sliding frame with the pin (see  on the scheme).

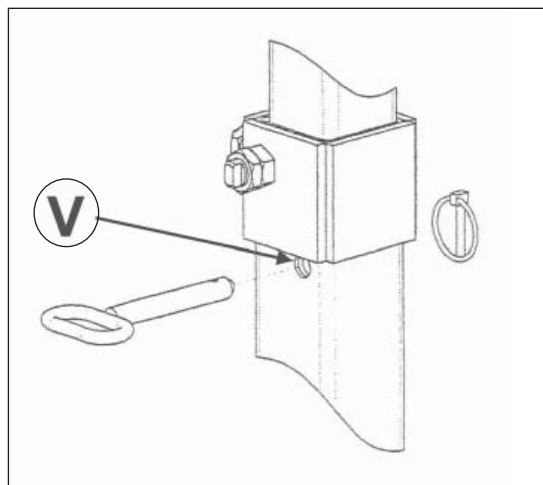

## 5 TROUBLESHOOTING

<b>PROBLEMS WHICH MAY OCCUR AFTER SWITCHING ON THE UNIT</b>			
<b>Problem</b>	<b>No.</b>	<b>Probable Cause</b>	<b>Checks - Remedies</b>
The blades rotate too slowly, even though the oil flow corresponds to recommendations and even after several minutes of operation	1	Calibration of pressure relief valves too low (or impurity on the valve seat).	Increase pressure to the recommended value or clean unit.
	2	Motor is worn out or deteriorated, too much internal play.	Check the oil flow on the drainage. If the flow is too high, change the motor, clean the hydraulic circuit, change the filters.
	3	Pump is worn out.	Check the increase in pressure on the pump or change the pump if necessary.
	4	Filter clogged.	Check the filter, change if necessary.
The blades rotate normally at cold temperature, but slow down when the temperature is stabilized	5	Type of oil is not suitable for the Trimmer (viscosity too low).	Check the oil and change if necessary for a suitable type.
	6	Motor or pump worn out.	See solution number 2 or 3.
The blades rotate too slowly, in spite of correct oil flow but speed increases proportionally at the temperature.	7	Calibration of pressure relief valves too low.	Increase pressure to the recommended value or clean.
	8	Oil not suitable (viscosity too high at low temperature).	Check the oil and change if necessary for a suitable type.
The temperature of the oil is over 158° (70° C).	9	Oil tank is too small.	Change to a higher capacity relative to the flow of the pump.
	10	Too much flow in gallons per minute.	Compare the maximum oil flow of the pump of the tractor with the maximum oil flow acceptable by the machine. <b>(Contact your dealer for more information)</b>
	11	Type of oil is not suitable (viscosity too high).	Change to a suitable oil.
	12	The oil is being bypassed inside the pressure relief valve.	Regulate pressure in the pressure relief valve to the recommended level.
	13	Clogging of the filter element.	Change the cartridge.
<b>NOTE: Work on the hydraulic system must be done by approved technicians, except for the cleaning and/or replacement of the cartridge filter.</b>			

## 6 ADJUSTMENTS

### 6.1 ADJUSTMENT OF THE INCLINATION OF ARMS:

#### a) First stage (6°):

Loosen nut (A) sufficiently in order to release the articulations (B) one of the other. Choose the best adjustment of the articulations retighten.

#### b) Second stage (less than 6°):

Loosen nut (A) and the screw (C) to release the arm. Pivot the arm to the desired position, retighten.

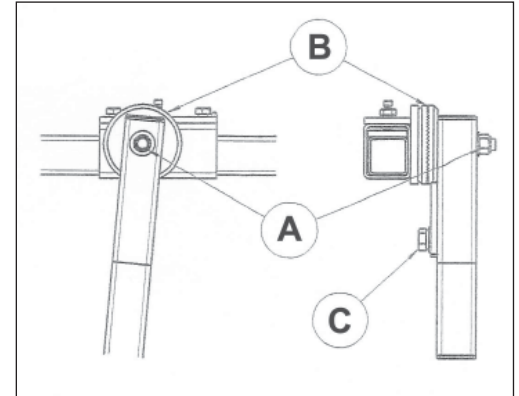

### 6.2 ADJUSTMENT OF THE PLAY IN THE TUBES:

The play in the sliding tubes is limited by an adjustable stop mechanism (1). In order to reduce the play resulting from wear, loosen the counternuts (2) and slightly tighten the center screws (3) in order to bring in contact the screw with the stop mechanism and the stop mechanism with the sliding tube (4). Retighten the counternuts (2).

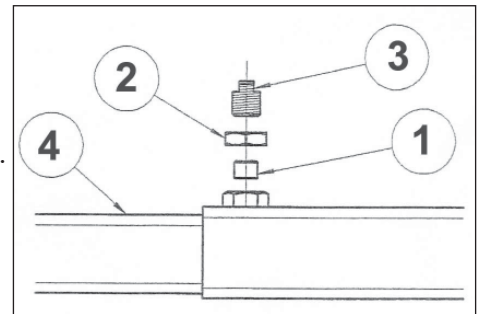

Check the plastic plug for wear, by removing the central screw. Replace it if necessary. **(Use only original spare parts - see table)**

Ref.	Part No.	Description
1	0501 4315	Plastic plug (Ht: 4mm)
	0501 4309	Plastic plug (Ht: 8mm)
	0501 4314	Plastic plug (Ht: 16mm)
2	0501 1208	Nut Hm 20 ZN
3	0501 0814	Adjusting Screw

### 6.3 ADJUSTMENT - SPEED OF CYLINDER'S ROD:

A device located on the cylinder makes to regulate the speed of displacement of the cylinder's rod. To do that, remove the nut (5), loosen the counternut (6), then adjust the screw (7) to obtain the desired speed. The more the screw is tightened, the more speed is decreased, conversely. Retighten the counternut by maintaining the screw, make sure that the seal (8) is in good condition, and reattach the nut (5). **Use only original spare parts - see references.**

Ref.	Part No.	Description
5	0501 1204	Nut M8
6	0501 1206	Nut M8 Hu
7	0501 0826	Screw STHC M8 x 25
8	0500 2009	Seal Ø 8.2 x 11.2 x 1

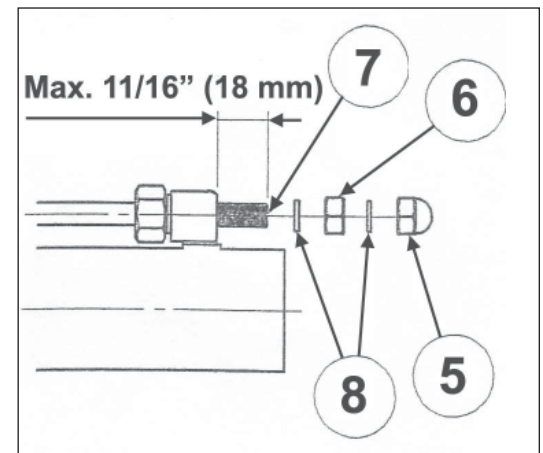

**Never remove the screw (7) when the hydraulic circuit is under pressure. Take care that the adjustment between back face of the screw and the union never exceeds 11/16".**

## 6 ADJUSTMENTS (CONTINUED)

### 6.4 ADJUSTMENT OF THE MECHANICAL PARTS - P2200 (SEE NEXT PAGE)

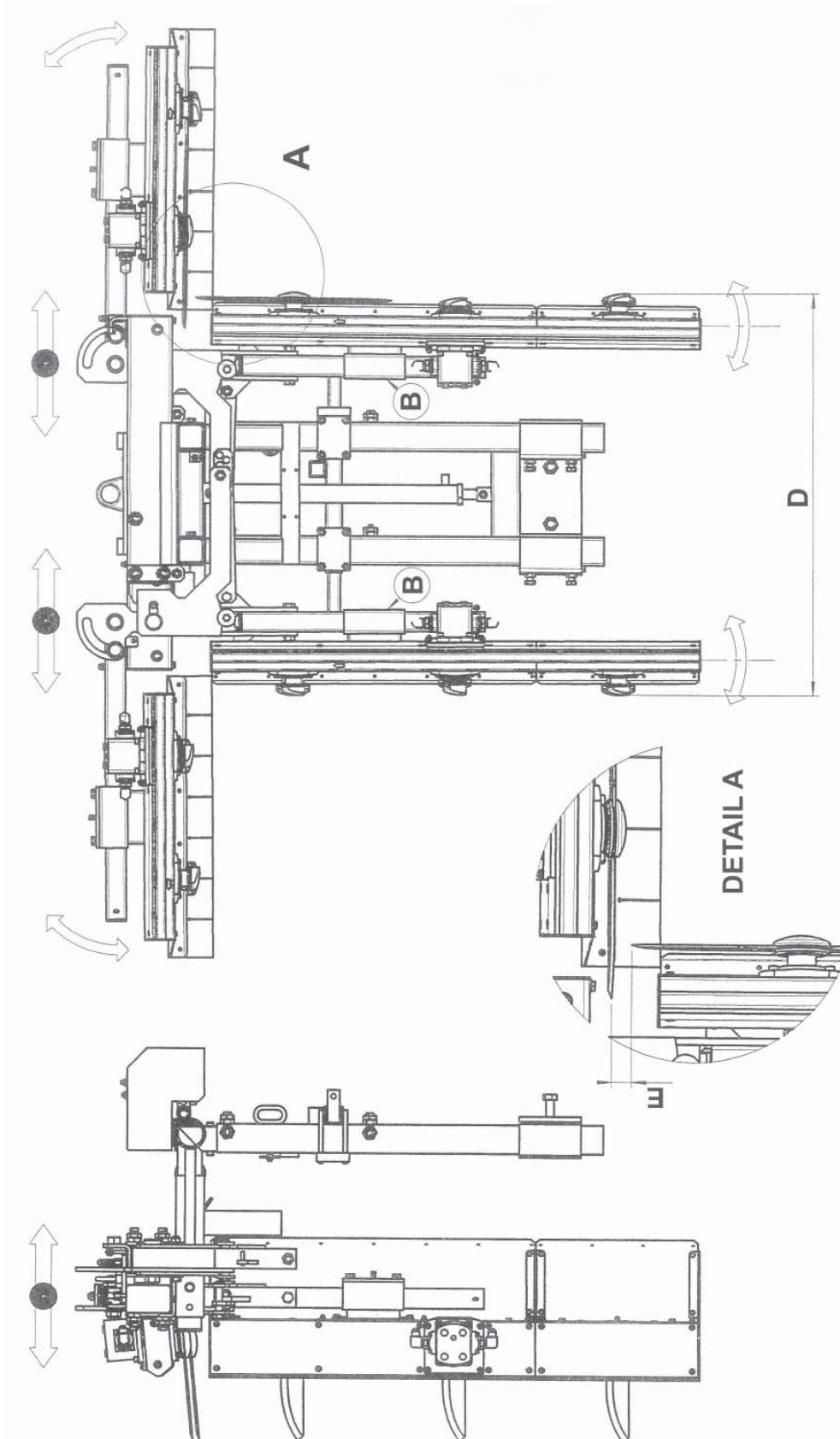

## 6 ADJUSTMENTS (CONTINUED)

### 6.4 ADJUSTMENT OF THE MECHANICAL PARTS - P2200

#### ADJUSTMENT OF THE VERTICAL & HORIZONTAL BLADES:

In order to maintain the maximum cut, the variation between the top and side blades should not be more than 1/8" (5 mm). For this adjustment loosen parts (**B** on pg. 25) slide to the correct spacing and tighten.

**Note:** This adjustment is necessary every time you adjust the cross slope.

#### ADJUSTMENT OF THE SLOPE OF THE TOP CUTTING ELEMENTS:

Loosen the screw (1) and (2). Pivot the arm until the desired position. Tighten.

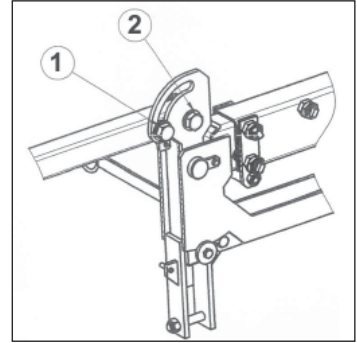

#### FOR TRIMMER WITH MANUAL ADJUSTMENT OF THE SLOPE:

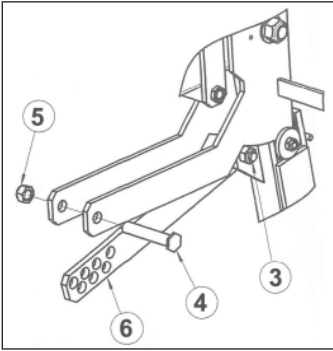

Loosen the bolt (3). Remove the bolt (4) and the nut (5). Give the angle chosen of the vertical cutting element. To put the bolt (4) in the nearest hole of the bar (6). Tighten the bolts (4) and (3).

#### MANUAL ADJUSTMENT OF THE DISTANCE D:

It is possible to increase or decrease the distance **D** (on page 25), (in addition of the hydraulic adjustment), slide the part (8) on their support. **Warning:** Then loosen only the nuts (7) and slide the tubes in order to obtain the desired distance. Tighten the nuts.

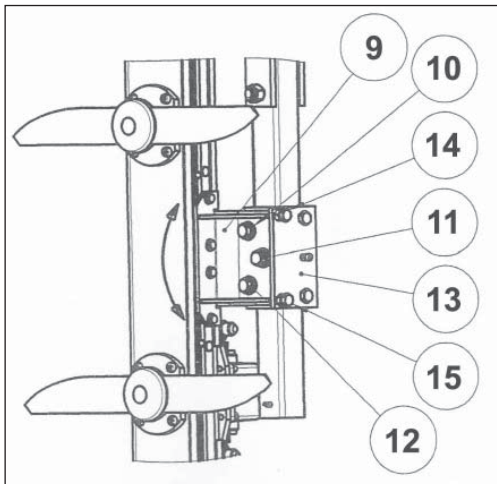
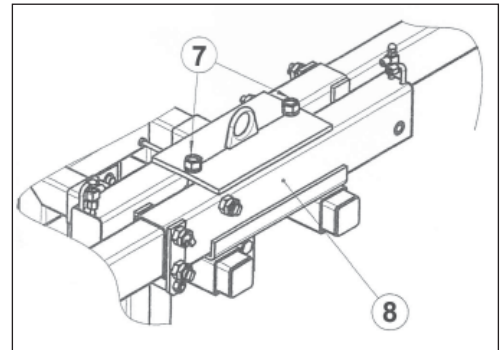

#### ADJUSTMENT OF THE ALIGNMENT OF THE VERTICAL CUTTING ELEMENTS:

Loosen the bolts (10), (11), (12), (14), (15) and swivel the vertical cutting element related to the part (9) compared to the part (13). Align vertically the left and right elements. Tighten the bolts (14) and (15) until they are resting against the vertical support element (9). Tighten the bolts (10), (11) and (12).



# 7 HYDRAULIC SYSTEM (ELECTRIC CONTROL)

**1 Simple effect & 3 double effect - Ref: 0502 2936**

**1 Simple effect & 5 double effect - Ref: 0502 2938**

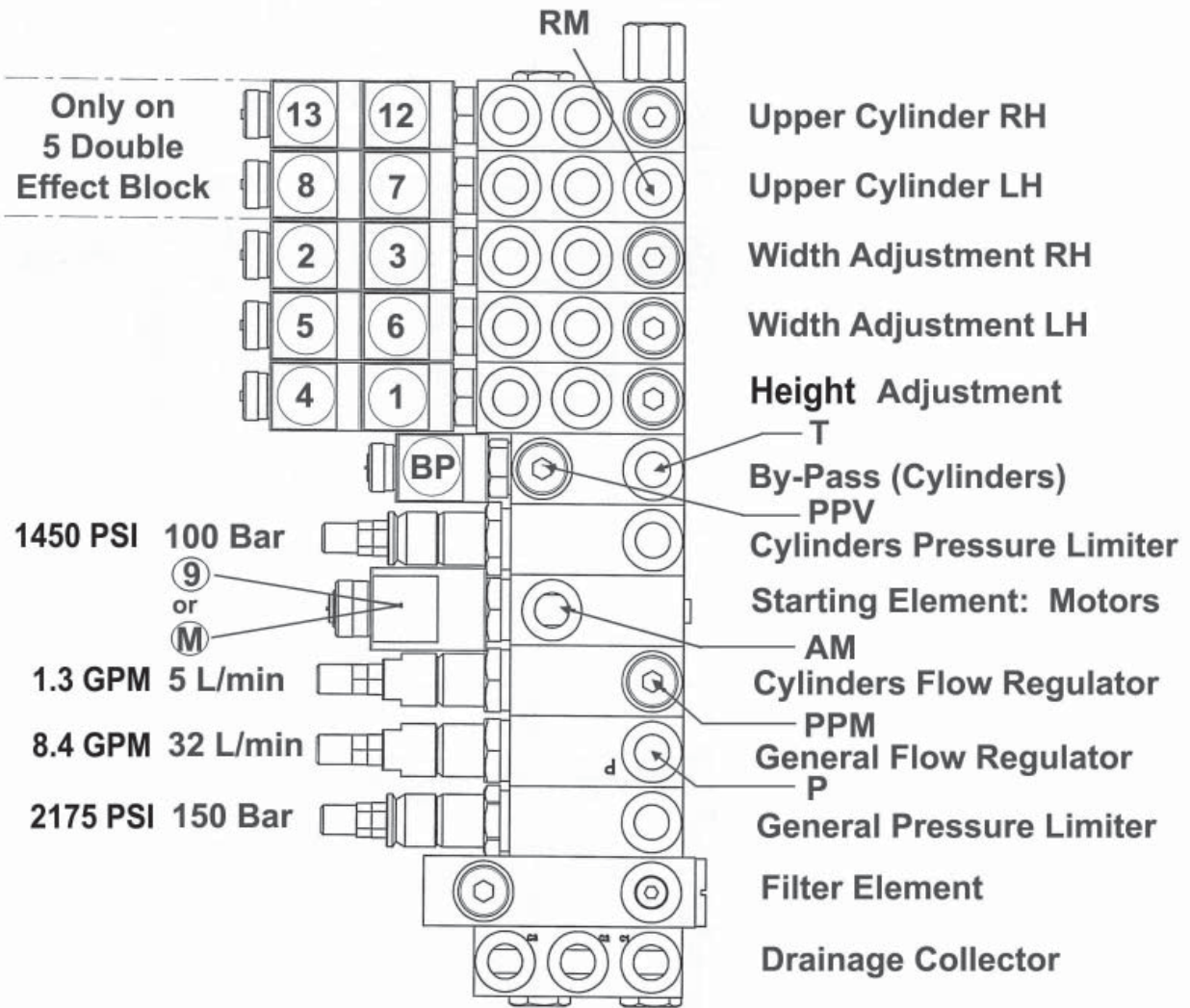

PPV: Cylinders Pressure Taker  
 PPM: Motors Pressure Taker  
 AM: Motors Supply

RM: Motors Return  
 P: General Power  
 T: Return



# 7 HYDRAULIC SYSTEM (CONTINUED)

## 7.1 P2200 STANDARD ELECTRIC CONTROL

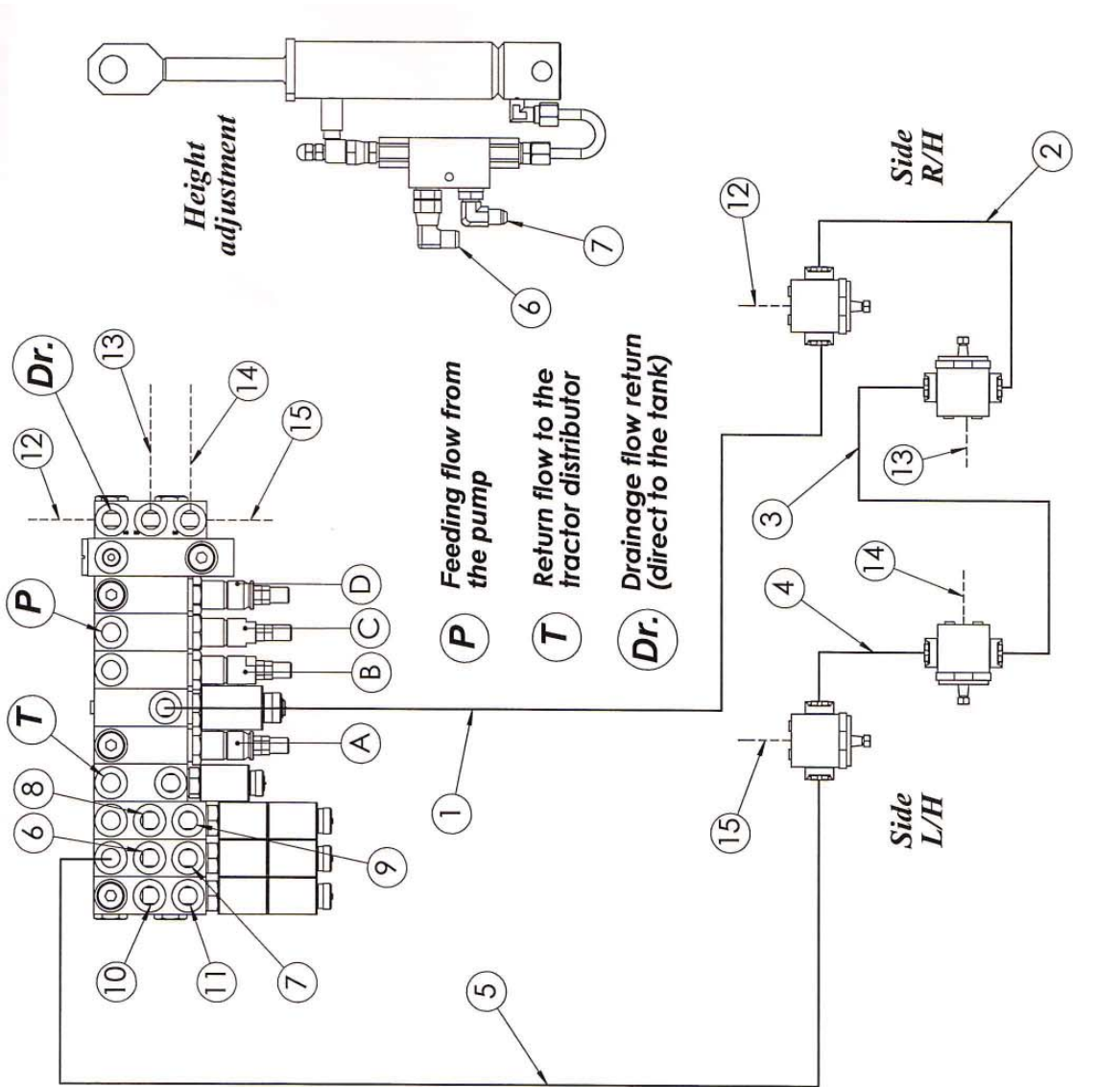

**Hydraulic components adjustments:**

- (A) Pressure: 1450 PSI (100 bars)
- (B) Flow: 1.3 G.P.M. (5 L/min)
- (C) Flow: 6.13 G.P.M. (27 L/min)
- (D) Pressure: 2175 PSI (150 bars)

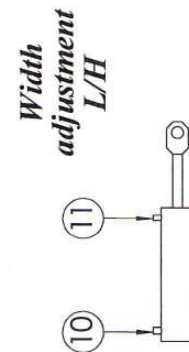
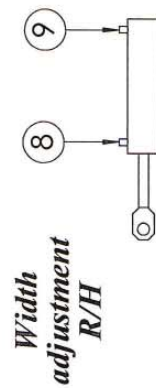

## 7 HYDRAULIC SYSTEM (CONTINUED)

### 7.2 ELECTRIC CONTROL HANDLE WITH JOYSTICK (NOW STANDARD EQUIPMENT)

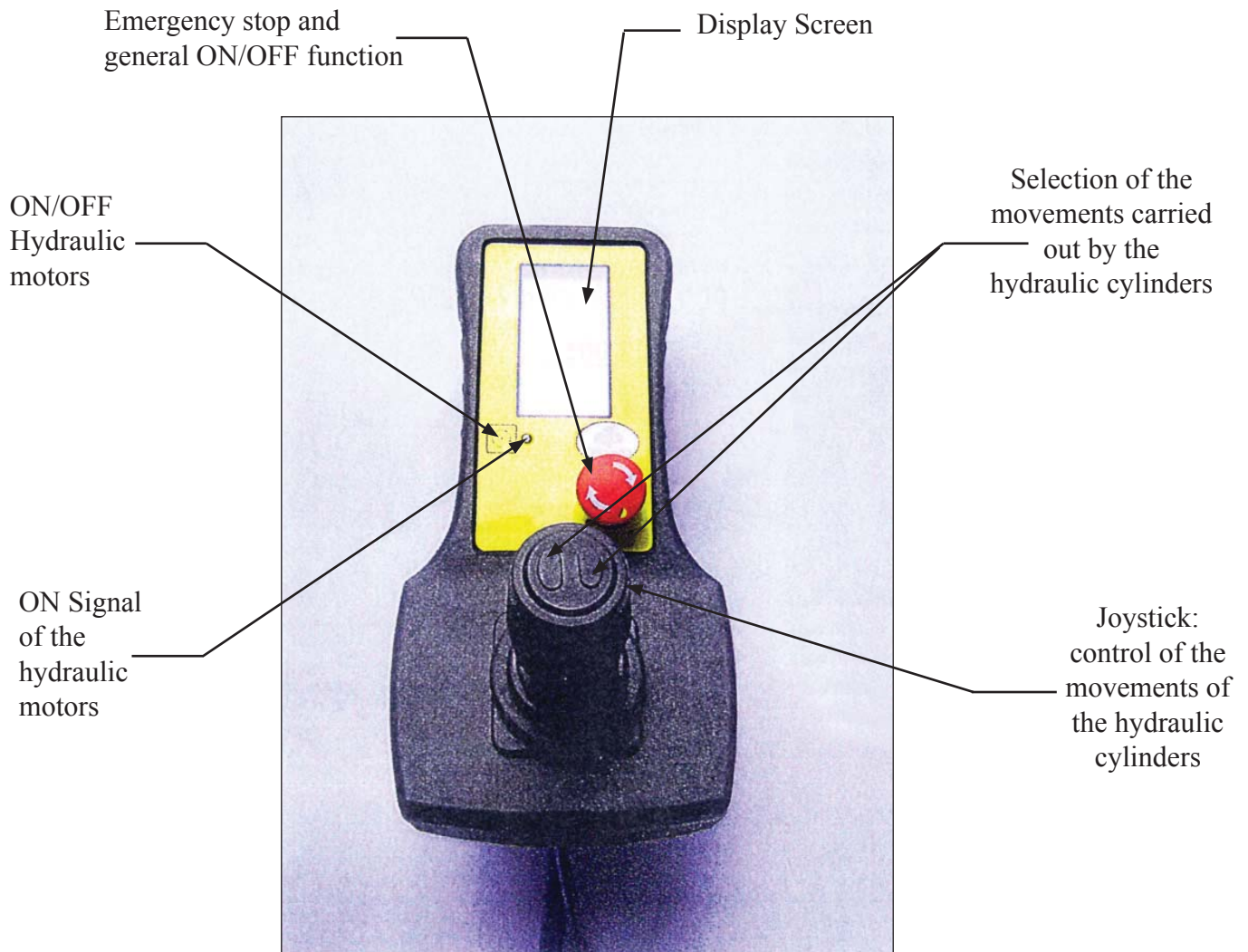

To carry out a movement of a hydraulic cylinder, operate the joystick by tilting it towards one of the 4 directions following the desired cylinder movement.

Functions are changed by pushing the button located in the center of the joystick.

1. First press the button in order to select the desired function.
2. Then tilt simultaneously the joystick (without releasing the button).

**NOTE:** To carry out another movement it is necessary to bring the level to the central position (neutral position), then use steps 1 and 2 to obtain the next function (cylinder movement).

#### **IMPORTANT:**

In order to optimize the longevity of the control handle, after each use, keep the handle in a clean and dry place, devoid of dust and grease.

# 7 HYDRAULIC SYSTEM (CONTINUED)

## 7.3 ELECTRIC CONTROL HANDLE WITH CROSS LEVER REFERENCE No. 0000 2404

**For machines equipped with  
1 to 5 double effect cylinders,  
without function of control for  
proportional valve**

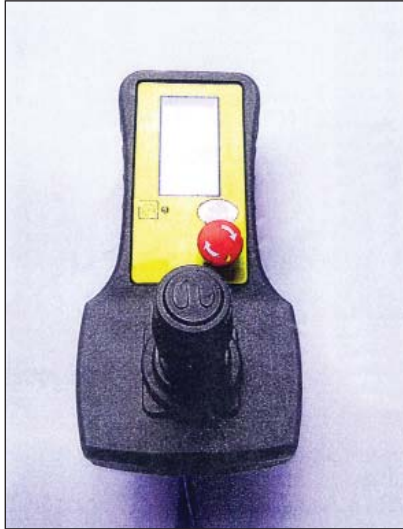

**Complete Electric  
Control Handle  
With Box, Wires  
and Female Plug:**

**0506 0051**

**Bundle of Wires  
and Male Plug  
(13 Connectors):**

**0506 1051**

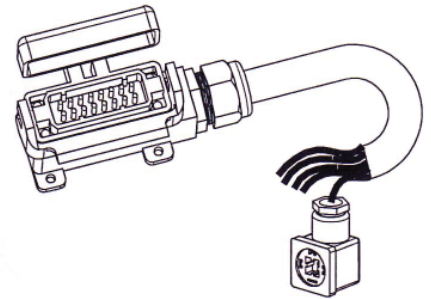
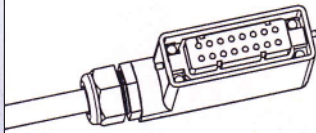

**Support:**

**0502 9872**

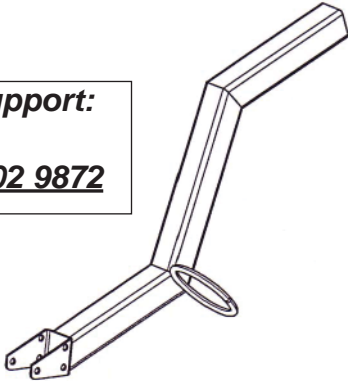

**Connectors 1 to 8, 12 and 13:**  
Double effect cylinder functions

**Connector 9:**  
ON/OFF Motors Function

**Connector 10:**  
By-pass Function

**Connector 11:**  
EVC Function (only in case of closed  
center hydraulic systems which work  
with the additional hydraulic unit -  
0000 1561)

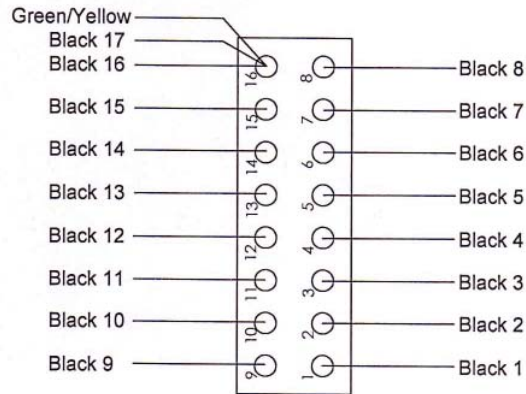

**Female  
plug**

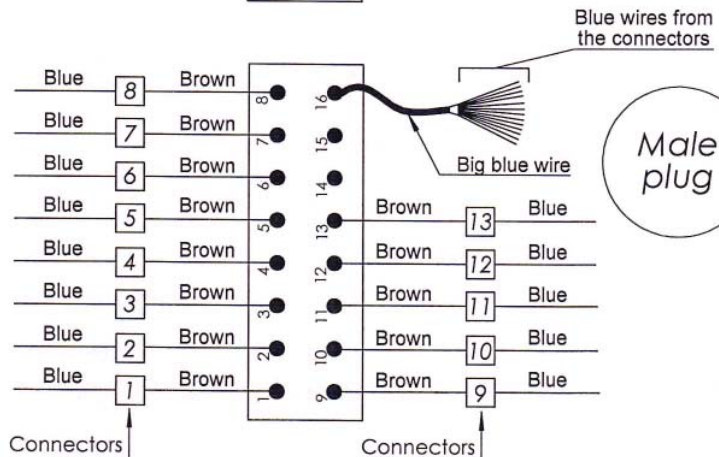

**Male  
plug**

# 8 MAINTENANCE

## 8.1 ANNUAL & PERIODIC MAINTENANCE

### ANNUAL MAINTENANCE:

When changing the oil of the hydraulic system replace the filter cartridge if it is polluted.  
Use only one of the recommended oils.

### PERIODIC MAINTENANCE DURING THE TRIMMER SEASON:

#### WEEKLY -

- After removing all vegetable debris from the unit, grease the sliding parts of the tubes using a brush.
- Check the play in the tubes. If it is too loose, carry out the necessary adjustments (see "Adjustments").

#### AFTER EACH TRIMMING SESSION -

- Clean all debris from the Trimmer
- Check all the blades (See "**Blades Maintenance**")
- Put on the protective covers

### BLADES:

The Collard Vine Trimmers feature stainless steel blades that never need sharpening. The blades are available in two lengths 400 mm (15 3/4") and 480 mm (18 7/8").

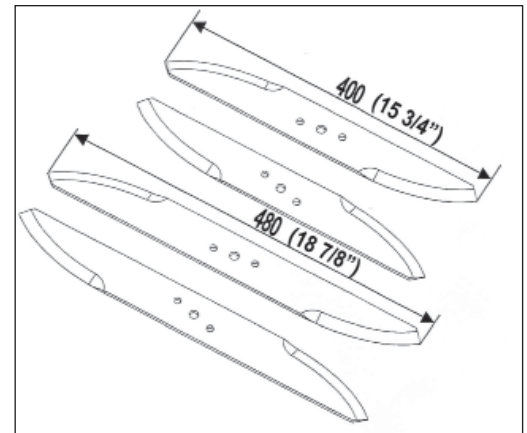

The blades are assembled bolted in the shaft by 2 ea. M8 bolts (See **Fig. 1**)

Thanks to a special system (patented by COLLARD) by the positioning of the holes for the bolts on the blades, it is impossible to mount a blade in an incorrect position or on the wrong side.

The last 3 numbers of the part number is engraved on the blade for easy reference.

### BLADE MAINTENANCE:

In order to maintain good trimming quality, blades must be cleaned after each trimming day. In order to do this, scrape off the vegetation which has accumulated with a knife. This operation can be significantly speeded up by using special S.S. blades.

**The blades must never be sharpened**, because of the risk of unbalancing them. Change them when the cutting edge becomes worn. (See "**Safety Instructions**").

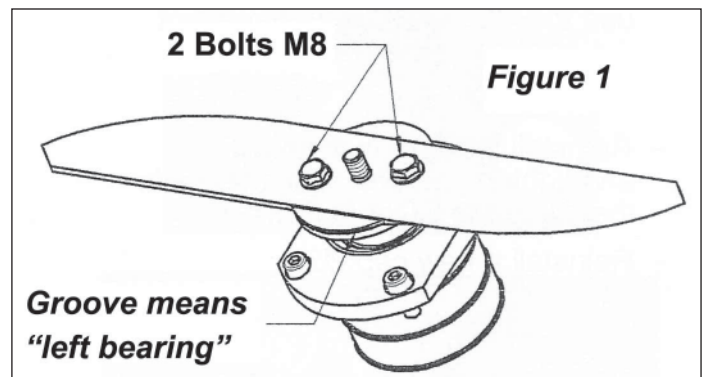



# 8 MAINTENANCE (CONTINUED)

## 8.2 REPLACEMENT OF THE BLADES



### WARNING - Think Safety When Replacing Blades

PART #	MATERIAL	ROTATION	LENGTH
0503 0171	S.S.	RH	400 mm(15 3/4")
0503 0172	S.S.	LH	400 mm(15 3/4")
0503 0169	S.S.	RH	480 mm (18 7/8")
0503 0170	S.S.	LH	480 mm (18 7/8")

Hardware Kit for mounting one blade - use part number 0503 0069 which consists of:

- 1 ea. 0501 7311 Locknut M10
- 1 ea. 0501 7926 Plug
- 2 ea. 0501 1861 Bolt, tensilock M8 x 12

**WEAR LEATHER GLOVES AND HAVE THE COLLARD SAFETY TOOL AVAILABLE (Figure 2).**

#### DISASSEMBLING:

- ❶ Remove cap Ø26
- ❷ Remove the M10 locknut holding the blade with the tool (Fig. 2)
- ❸ Remove the cup
- ❹ Remove the 2 bolts M8
- ❺ The blade is now free to remove

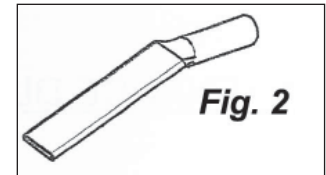

#### REASSEMBLING:

- ❶ Install the new blade with the cutting edge facing in toward the frame. (This patented system ensures the correct direction of the blade)
- ❷ Re-install the bolts M8 torque to 2.2 ft/lb. Use the COLLARD blade tool to prevent the turning of the blade.
- ❸ Install **NEW** locknut M10 to 3.6 ft./lb. and always hold the blade in place with the COLLARD tool.
- ❹ Install **NEW** cap Ø26 (see next page for details).

Please also note (Fig. 3) that the left hand bearings have a groove in the flange.

On the vertical cutting elements, the cut is done going up from the ground (see Fig. 3A)

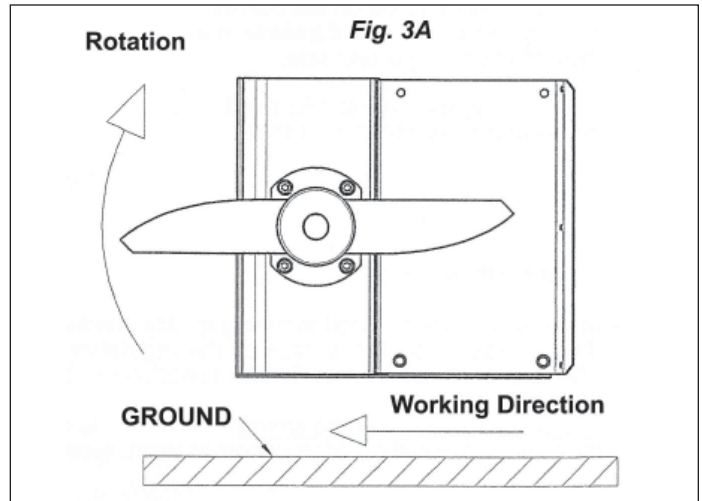
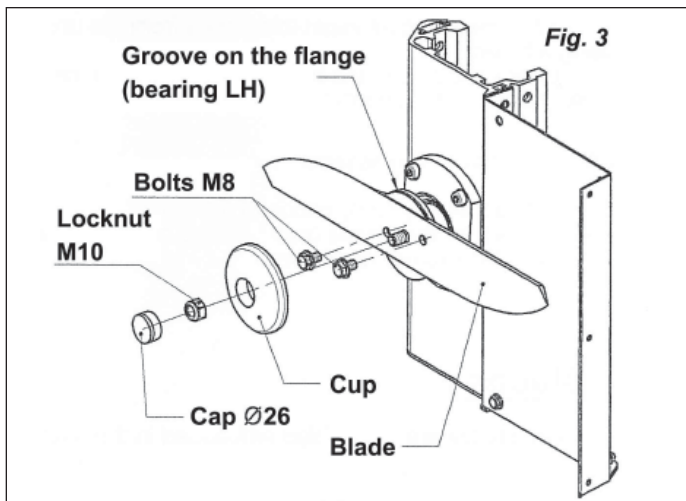

## 8 MAINTENANCE (CONTINUED)

### 8.3 ASSEMBLY OF THE PLASTIC CAP Ø26



**WARNING - Before changing blades, the machine and the hydraulic pump must be stopped. Operator must wear leather gloves.**

Insert the plastic plug, with a mallet (**Fig. 2**). When it is correctly placed, the plastic plug should be flush with the cap. A plastic chip appears during the assembly of the plastic plug (**Fig. 3**). Remove by simply pulling off by hand.

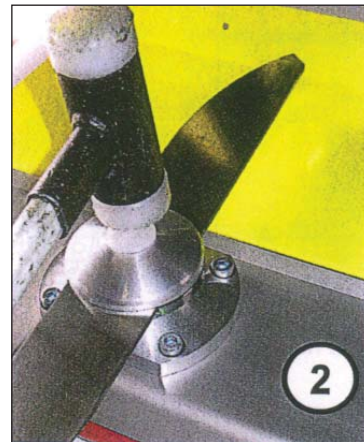

By reviewing the drawing below, you can observe the rotations direction of the blades on the cutting element.

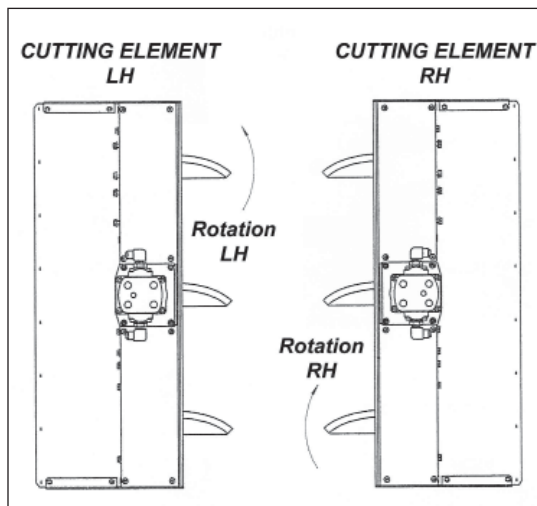

Blades RH operate in **CLOCKWISE**  
(No groove on the flange)

Blades LH operate in **COUNTER CLOCKWISE**  
(With groove on the flange)

When sitting in the tractor seat looking forward.

## 8 MAINTENANCE (CONTINUED)

### 8.4 REPLACEMENT OF THE BELTS

#### DISASSEMBLING:

- 1 Remove the cutting element housing
- 2 Remove the belt by drawing it toward the outside of the pulley. Pull the belt out by turning it forward in the direction of the arrows.

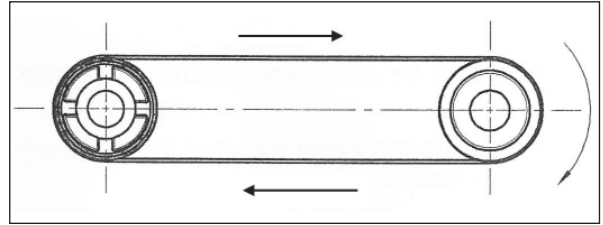

**NOTE:** The belt part number is shown on the inside and outside of the belt.

#### REMOUNTING:

**NOTE:** To insure the quality of the Vine Trimmer use Collard O.E.M. parts only.

#### CAUTION:

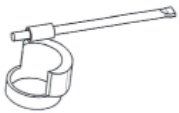

In order to avoid damage to the belt assembly use Collard assembly tool, order this tool using part number 0105 0157. This tool should be used with the light alloy pulleys only. **Do Not** use on the hydraulic motor pulleys.

#### Follow the belts rotation:

- When mounting be sure to note the rotation direction for the position of the belt joint (**Fig. 5**). The direction of the belt is indicated on both the inside and outside of the belt.

#### Mounting of the belts:

- Position the green face of the belt on the outside of the pulley and the yellow side on the inside.
- Place the tool on the pulley (**Fig. 6**).
- Position the belt to be assembled in the groove of the opposite pulley.
- Rotate as shown in **F** to engage the belt on the assembly tool (**Fig. 7**).
- Remove the assembly tool.
- Finish positioning the belt by turning it by hand.

