

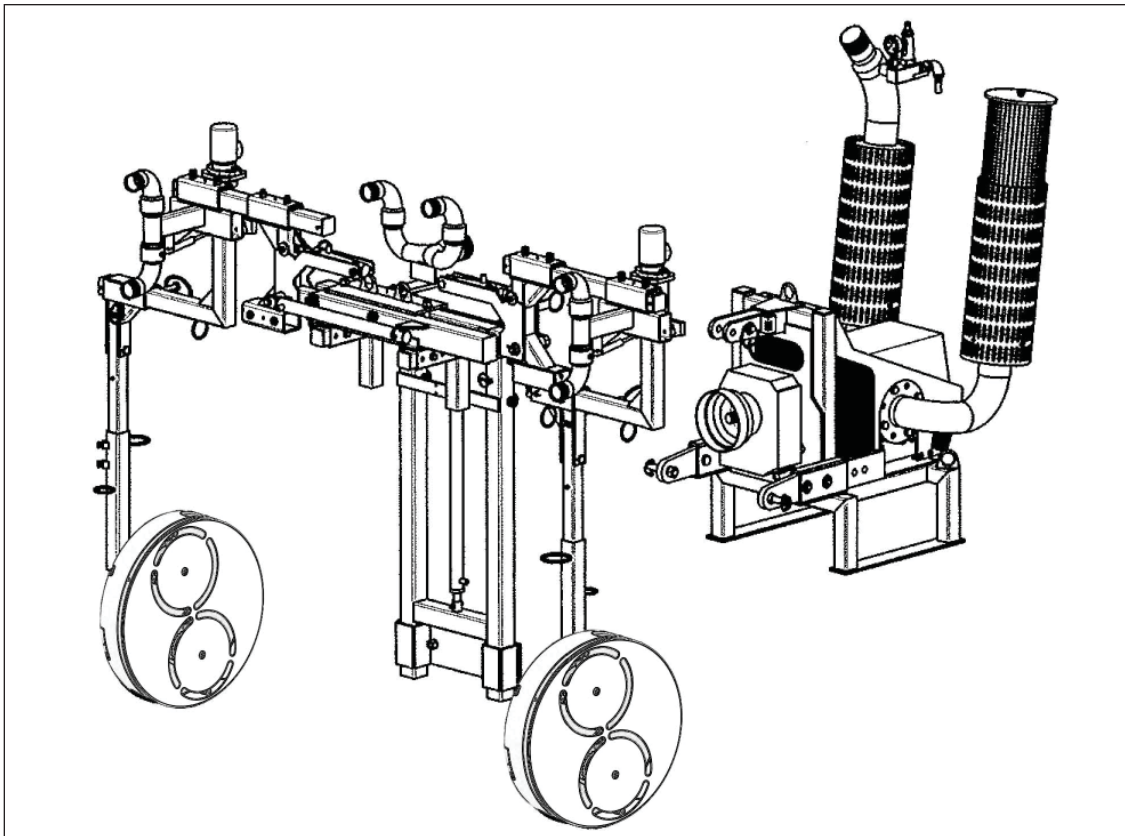

**COLLARD®**

# LEAF REMOVERS



## Installation, Operation, Service & Parts Manual For Model E2200FR - Code #0422 0250

*Marketed by:*



13477 Benson Ave. • Chino, CA • Ph: 909/548-4848 • Fax: 909/548-4747

# DECLARATION OF CONFORMITY

---

**MANUFACTURER:** Ets COLLARD SA

**ADDRESS:** 51150 Bouzy (France)

Declare:

The COLLARD equipment:

S/N:

Year of construction:

Which was delivered to you is in conformity, with the general safety rules for "machines".  
(Directive 89/292/EEC)

And, declares in addition that the EEC standard EN 706, relating to the particular safety requirements for Leaf Remover machines has been applied.

We draw your attention to read very attentively this manual before using the machine for the first time, inside of which you will find all the necessary informations to a safe and correct use and for a good maintenance of your new machine, for your satisfaction, for a long time.

For your protection, and that of your entourage, absolutely respect all the safety instructions.

Thank you for your confidence.

# LEGAL NOTIFICATIONS



**FEDERATION  
DES INDUSTRIES MECANIQUES**  
Department of Legal Affairs and Environment

## REPLACING PARTS WITH «NON CERTIFIED ORIGINAL PARTS»

### WARNING

to equipment users  
and to imitated parts manufacturers or sellers  
REGARDING LEGAL RISKS - SAFETY - COUNTERFEITING

**IMITATED OR  
FITTED PARTS**

1. CHANGING OR MODIFYING COMPONENTS WITH OTHERS THAN THOSE ASSEMBLED AND RECOMMENDED BY THE MANUFACTURER, IS LIKELY TO QUESTION AGAIN THE INITIAL SAFETY CONDITIONS OF THE EQUIPMENT.

Any like operation on the equipment will be fully chargeable to he who will have intervened, and will be likely to challenge the validity of the manufacturer delivered EC marking.

In this event, the EC declaration of compliance lapses and THE MANUFACTURER WILL DISCLAIM HIS REGULATORY LIABILITY.

2. PARTS COUNTERFEITING AND UNFAIR COMPETITION CARRY HEAVY CIVIL AND CRIMINAL PENALTIES.

**Counterfeiting or infringement involves** the manufacturer's, the dealer's/retailer's, or even in some cases the imitated parts user's **civil and criminal liability**.

**Unfair competition involves** the manufacturer's and the «slavish imitations» dealer's **civil liability**, in so far as they take unjustified benefit of this operation, distort usual rules of competition law by misappropriating the manufacturer's efforts of design, adjustment, research of best adequacy and know-how.

The mechanical engineering industries manufacturers

⊘ Warn parts manufacturers and dealers, duplicating or selling original parts, about the legal risk of imitations and unfair competition as for manufacturing and distributing slavish imitations.

⊘ Draw users' attention to the risk for their EC declaration to lapse in case the safety conditions originally defined by the equipment manufacturer would be modified, and call for them not to participate in the intellectual property misappropriation and plundering which certain dishonest operators indulge in.

# TABLE OF CONTENTS

<u>SECTION</u>	<u>DESCRIPTION</u> .....	<u>PAGE</u>
1	<b>Introduction</b> .....	<b>1</b>
1.1	Operator's Responsibility .....	1
1.2	Conditions for Use .....	2
2	<b>Safety</b> .....	<b>3 - 8</b>
2.1	General Safety .....	4
2.2	Equipment Safety Guidelines .....	5
2.3	Safety Training .....	6
2.4	Safety Signs .....	6
2.5	Preparation .....	7
2.6	Operational Safety .....	8
3	<b>Assembly</b> .....	<b>9 - 11</b>
3.1	Mounting Leaf Remover to Tractor .....	9
3.2	Installation .....	10
3.3	Final Assembly .....	11
4	<b>Defoliator</b> .....	<b>12 - 13</b>
4.1	Various Uses of the Collard Defoliator .....	12
4.2	Twin Rotors Defoliation Heads .....	12
4.3	Defoliation From The Top .....	13
5	<b>Operation</b> .....	<b>14 - 18</b>
5.1	Starting The Leaf Remover .....	14
5.2	Adjustment of Leaf Remover .....	15
5.3	Calibrating the Nozzles RPM Speed .....	16
5.4	Hydraulic Cylinder Adjustment .....	17
5.5	Seepage on "NX" Air Compressor .....	18
6	<b>Maintenance</b> .....	<b>19 - 24</b>
6.1	Maintenance of "NX" Air Compressor .....	19
6.2	Maintenance of Gearbox .....	20
6.3	Flex Coupling .....	20-21
6.4	Daily Maintenance and Adjustments .....	22
6.5	Utilization of Tractor/Air Compressor .....	23
6.6	Off Season Storage & Handling .....	23
6.7	Before Starting After Off Season .....	24
7	<b>Troubleshooting</b> .....	<b>25</b>

# TABLE OF CONTENTS (CONTINUED)

<u>SECTION</u>	<u>DESCRIPTION</u> .....	<u>PAGE</u>
<b>8</b>	<b>Leaf Remover Spare Parts .....</b>	<b>26 - 41</b>
8.1	Electric Command E2200FR .....	PL 4012/5130 ..... 28
8.2	Hydraulic Diagram .....	PL 3040 ..... 29
8.3	High Large Vertical Frame Unit.....	PL 2259 ..... 30
8.4	Horizontal Arm L/H.....	PL 2753 ..... 31
8.5	Horizontal Arm R/H.....	PL 2756 ..... 32
8.6	Air Distributor Kit .....	PL 2801 ..... 33
8.7	Reversible System Kit .....	PL 2749 ..... 34-35
8.8	Retractable Arm.....	PL 2804 ..... 36
8.9	Lower Arm .....	PL 2802 ..... 37
8.10	Large Lower Fixing .....	PL 2262 ..... 38
8.11	Arm Units With Twin Rotors.....	PL 4696 ..... 39
8.11a	Defoliating Head Twin Rotor.....	PL 4516 ..... 40-41
<b>9</b>	<b>Rear Booster Spare Parts .....</b>	<b>42 - 51</b>
9.1	Rear Booster on 3-Pt. Frame .....	PL 5020 ..... 42-43
9.2	Air Intake Pipe Kit .....	PL 5011 ..... 44
9.3	Air Exhaust Pipe Kit.....	PL 5129 ..... 45
9.4	Pressure Checking Unit .....	PL 5008 ..... 46
9.5	Relief Valve Assembly .....	PL 5009 ..... 47
9.6	Motor Kit.....	PL 3882 ..... 48
9.7	Complete Air Distributor Kit.....	PL 3882 ..... 48
9.8	Air Distributor Kit .....	PL 3883 ..... 49
9.9	Coupling Assembly With Boss .....	PL 5005 ..... 50
9.10	Complete Angle Brake Assembly.....	PL 4365 ..... 51
<b>10</b>	<b>Hydraulic Parts .....</b>	<b>52 - 55</b>
10.1	Cylinder DE 35-25 .....	PL 1604 ..... 52
10.2	Double Effect Cylinder Ø35-18.....	PL 1601 ..... 53
10.3	Cylinder Double Effect 35-18 .....	PL 1620 ..... 54
10.4	Complete Non Return Security Valve JIC.....	PL 2986 ..... 55
<b>11</b>	<b>Options.....</b>	<b>56</b>
11.1	Prefiltration Kit.....	PL 2708 ..... 56
11.2	Ventilation Kit for Raptor .....	PL 2707 ..... 56

# NOTES

---

# 1 INTRODUCTION

Congratulations on your selection of a Collard Leaf Remover.

## **HISTORY**

The COLLARD family has been servicing grape growers for 5 generations. Andre Collard invented the first mechanical vine trimmer in 1962. Since that development COLLARD has made numerous improvements and continues to be the world leader in trimmers.

## **QUALITY CONTROL**

Every stage in the production process is controlled to guarantee superior quality. After final assembly, each machine is run through a detailed test where everything is checked - rotation speed, operating pressure, hydraulic cylinders, flow rates, etc. All this is done to insure that every machine leaving the factory is in perfect working order.



## 1.1 OPERATOR'S RESPONSIBILITY

Safe, efficient and trouble free operation of your Leaf Remover requires that you and anyone else who will be operating or maintaining the machine, read and understand the Safety, Installation, Operation, Maintenance, and Troubleshooting information contained within the Operator's Manual.

Keep this manual handy for frequent reference and to pass on to new operators or owners. Call your tractor dealer if you need assistance, information or additional copies of the manuals.

**OPERATOR ORIENTATION** - The directions left, right, front and rear, as mentioned throughout this manual, are as seen from the driver's seat and facing in the direction of travel.

NAME: \_\_\_\_\_

PURCHASED FROM: \_\_\_\_\_

DATE OF PURCHASE: \_\_\_\_\_

CODE NUMBER: \_\_\_\_\_

SERIAL NUMBER: \_\_\_\_\_

---

## 1.2 CONDITIONS FOR USE

### **MACHINE USE** -

This machine is intended exclusively to trim excess vegetation in vineyards. Any other use is not acceptable for this product and is prohibited.



### **QUALIFICATION OF THE OPERATOR:**

The machine ***must*** be used, maintained and repaired only by people who know the procedures and safety requirements.

### **RESPONSIBILITY OF THE MANUFACTURER AND THE USER** -

Follow closely the regulations of installation, operation, adjustment, maintenance and repair contained in this manual.

Use exclusively original Collard spare parts and accessories in conformity according to the recommendations of the manufacturer.

Any modification of the machine and its accessories (mechanics, electric or hydraulics) made by yourself or by another person not authorized, can make your machine dangerous.

In the event of damage or injuries, the responsibility of the Collard company will be entirely released.



# SAFETY ALERT SYMBOL

This Safety Alert symbol means **ATTENTION! BECOME ALERT! YOUR SAFETY IS INVOLVED!**

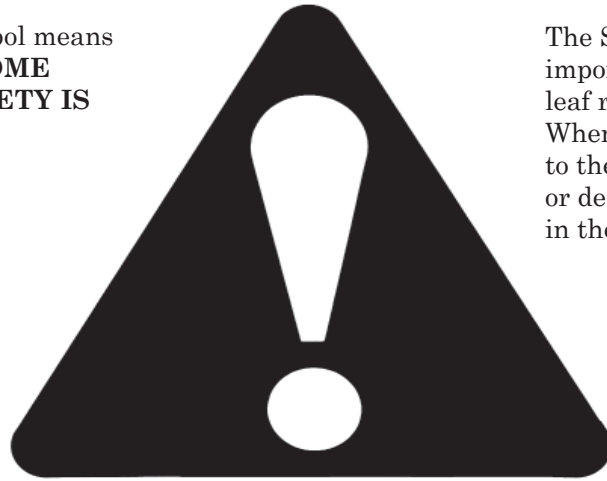

The Safety Alert symbol identifies important safety messages on the leaf remover and in the manual. When you see this symbol, be alert to the possibility of personal injury or death. Follow the instructions in the safety message.

Why is SAFETY important to you?

### 3 Big Reasons

**Accidents Disable and Kill**  
**Accidents Cost**  
**Accidents Can Be Avoided**

### SIGNAL WORDS:

Note the use of the signal words **DANGER**, **WARNING** and **CAUTION** with the safety messages. The appropriate signal word for each message has been selected using the following guide-lines:

**SI NO LEE INGLES, PIDA AYUDA A AIGUIEN QUE SI LO LEA PARA QUE LE TRADUZCA LAS MIDIDAS DE SEGURIDAD.**

**DANGER** - Indicates an imminently hazardous situation that, if not avoided, will result in death or serious injury. This signal word is to be limited to the most extreme situations typically for machine components which, for functional purposes, cannot be guarded.

**WARNING** - Indicates a potentially hazardous situation that, if not avoided, could result in death or serious injury, and includes hazards that are exposed when guards are removed. It may also be used to alert against unsafe practices.

**CAUTION** - Indicates a potentially hazardous situation that, if not avoided, may result in minor or moderate injury. It may also be used to alert against unsafe practices.

If you have any questions not answered in this manual or require additional copies or the manual is damaged, please contact your dealer.

## 2.1 GENERAL SAFETY

**YOU** are responsible for the **SAFE** operation and maintenance of your implement. **YOU** must ensure that you and anyone else who is going to operate, maintain or work around the leaf remover be familiar with the operating and maintenance procedures and related **SAFETY** information contained in this manual. This manual will take you step-by-step through your working day and alerts you to all good safety practices that should be adhered to while operating the leaf remover.

Remember, **YOU** are the key to safety. Good safety practices not only protect you, but also the people around you. Make these practices a working part of your safety program. Be certain that **EVERYONE** operating this equipment is familiar with the recommended operating and maintenance procedures and follows all the safety precautions. Most accidents can be prevented. Do not risk injury or death by ignoring good safety practices.

- Leaf Remover owners must give operating instructions to operators or employees before allowing them to operate the machine, and at least annually there after per OSHA (Occupational Safety and Health Administration) regulation 1928.57.
- The most important safety feature on this equipment is a **SAFE** operator. It is the operator's responsibility to read and understand **ALL** Safety and Operating instructions in the manual and to follow these. Most accidents can be avoided.
- A person who has not read and understood all operating and safety instructions is not qualified to operate the machine. An untrained operator exposes himself and bystanders to possible serious injury or death.
- **DO NOT** modify the equipment in any way. Unauthorized modification may impair the function and/or safety and could affect the life of the equipment.
- **Think SAFETY! Work SAFELY!**

1. Read and understand the Operator's Manual and all safety signs before operating, maintaining, or adjusting the leaf remover.



2. Have a first-aid kit available for use should the need arise and know how to use it.



3. Have a fire extinguisher available for use should the need arise and know how to use it.



4. Wear appropriate protective gear. This list includes but is not limited to:

- A hard hat
- Protective shoes with slip resistant soles
- Protective goggles, glasses or face shield
- Heavy gloves
- Protective clothing

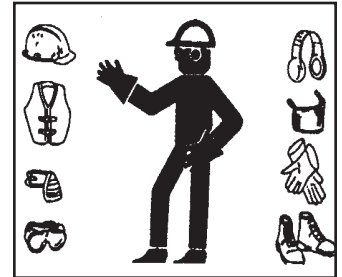

5. **DO NOT** allow riders.



6. Wear suitable ear protection for prolonged exposure to excessive noise.

7. Place all controls in neutral, stop tractor engine, set park brake, remove ignition key and wait for all moving parts to stop before servicing, adjusting, repairing, or unplugging.

8. Clear the area of people, especially small children, before starting.

9. Review safety related items annually with all personnel who will be operating or maintaining the leaf remover.

## 2.2 EQUIPMENT SAFETY GUIDELINES

Safety of the operator and bystanders is one of the main concerns in designing and developing a leaf remover. However, every year many accidents occur which could have been avoided by a few seconds of thought and a more careful approach to handling equipment. You, the operator, can avoid many accidents by observing the following precautions in this section. To avoid personal injury or death, study the following precautions and insist those working with you, or for you, follow them. If potentially dangerous situations are known, accidents can be prevented!

- The leaf remover, as described in this instruction and maintenance booklet, has been specifically designed for trimming excess vegetation in vineyards. Any other use jeopardizes the operator's safety and the machine integrity.

In each of the following (3) three situations, the cutting blade rotation ***must be turned off.***

1. Before starting the tractor.
  2. When transporting the tractor/leaf remover.
  3. Whenever the driver exits the tractor.
- **Under no circumstances should young children be allowed to work with this equipment. Do not allow persons to operate or assemble this unit until they have read this manual and have developed a thorough understanding of the safety precautions and of how it works. Review the safety instructions with all users annually.**
  - Do not modify the equipment in any way. Unauthorized modification may impair the function and/or safety and could affect the life of the equipment.

Only operate this leaf remover on a properly sized and equipped tractor.

Before doing any cleaning, adjusting, repairing or maintenance operation on the leaf remover:



- Turn off the tractor engine.
- Lower all cylinders to the base of their stroke, so that the leaf remover is in the lowest position.
- All the removable protection devices must be in place, except when working on the blades.

**If the tractor does not have a cab, protective glasses must be worn at all times.**

Before use, make sure all bolts and nuts are tightened, particularly on the brackets between the leaf remover and tractor.

When putting the blades in motion and at all times during operations, nobody except the tractor operator should be in the area.

When leaving vineyard rows turn off the cutting mechanism.

After each use, the protection guard must be replaced to the front side of the blades. The guard must also be in place when transporting the tractor/leaf remover. No fixed protection part may be modified or removed from the machine.

When handling the leaf remover you must use the lifting rings which are provided for that purpose.

As soon as any abnormal vibration is felt, stop and inspect the motor or have your dealer inspect until the cause has been identified.

When working on the cutting blades requiring their removal or cleaning, be sure to wear leather gloves, to avoid injury in case of contact with the blade cutting edges. The blades have been balanced at the factory. Normal use should not affect the cutting edge. Any blade which receives an impact, becomes deformed or marked must be replaced. **DO NOT TRY TO REPAIR THE BLADE.** Each time the blades are removed, the NYLSTOP nuts must be replaced with new ones.

The hydraulic components are set and tested at the factory. Your dealer should be contacted if adjustments are required.

**IMPORTANT:** The identification plate, bearing the equipment type and serial number must never be removed from the leaf remover.

Nobody is authorized to **ever** be in the area when the leaf remover is in operation, except the operator, who **must never** leave the tractor when the blades are moving.

**Never**, for any reason, should you clean or remove vegetation when the leaf remover is operating.

## 2.3 SAFETY TRAINING

Safety is a primary concern in the design and manufacture of our products. Unfortunately, our efforts to provide safe equipment can be wiped out by a single careless act of an operator or bystander.

In addition to the design and configuration of equipment, hazard control and accident prevention are dependent upon the awareness, concern, prudence and proper training of personnel involved in the operation, transport, maintenance and storage of this equipment.

It has been said, "***The best safety feature is an informed, careful operator.***" We ask you to be that kind of an operator. It is the operator's responsibility to read and understand ALL Safety and Operating instructions in the manual and to follow these. Accidents can be avoided.



Working with unfamiliar equipment can lead to careless injuries. Read this manual, and the manual for your tractor, before assembly or operating, to acquaint yourself with the machines. If this machine is used by any person other than yourself, or is loaned or rented, it is the machine owner's responsibility to make certain that the operator, prior to operating:

- a. Reads and understands the operator's manuals.
- b. Is instructed in safe and proper use.

Should ownership of the equipment be transferred, this manual must also be transferred.

Know your controls and how to stop tractor, engine and machine quickly in an emergency. Read this manual and the one provided with your tractor.

Train all new personnel and review instructions frequently with existing workers. Be certain only a properly trained and physically able person will operate the machinery. A person who has not read and understood all operating and safety instructions is not qualified to operate the machine. An untrained operator exposes himself and bystanders to possible serious injury or death. If the elderly are assisting with farm work, their physical limitations need to be recognized and accommodated.

For any part of this manual that you do not understand, contact your dealer.

## 2.4 SAFETY SIGNS

1. Safety decals and this manual must be considered a permanent part of your equipment.
2. Keep safety signs clean and legible at all times.
3. Replace safety signs that are missing or have become illegible.
4. Replaced parts that displayed a safety sign should also display the current sign.
5. Safety signs are available from your authorized dealer.

### How To Install Safety Signs:

- Be sure that the installation area is clean and dry.
- Be sure temperature is above 50° F (10° C).
- Determine exact position before you remove the backing paper.
- Remove the smallest portion of the split backing paper.
- Align the sign over the specified area and carefully press the small portion with the exposed sticky backing in place.
- Slowly peel back the remaining paper and carefully smooth the remaining portion of the sign in place.
- Small air pockets can be pierced with a pin and smoothed out using the piece of sign backing paper.

## 2.5 PREPARATION

1. Never operate the tractor and leaf remover until you have read and completely understand this manual, the Tractor Operator's Manual and each of the Safety Messages found on the safety signs on the tractor and leaf remover.

2. Personal protection equipment, including hard hat, safety glasses, safety shoes and gloves are recommended during assembly, installation, operation, adjustment, maintaining, repairing, removal or moving the implement. **DO NOT** allow long hair, loose fitting clothing or jewelry to be around equipment.

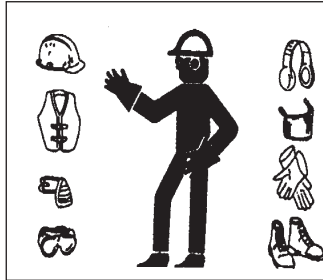

3. **PROLONGED EXPOSURE TO LOUD NOISE MAY CAUSE PERMANENT HEARING LOSS!**

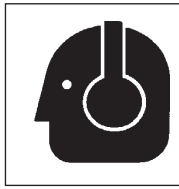

Tractors with or without equipment attached can often be noisy enough to cause permanent, partial hearing loss. We recommend that you wear hearing protection on a full-time basis if the noise in the Operator's position exceeds 80db. Noise over 85db on a long-term basis can cause severe hearing loss. Noise over 90db adjacent to the Operator over a long-term basis may cause permanent, total hearing loss.

**NOTE:** Hearing loss from loud noise (from tractors, chain saws, radios, and other such sources close to the ear) is cumulative over a lifetime without hope of natural recovery.

4. Always consider the features of the area where work is taking place. When the equipment is running, it is forbidden to stand within the field of action of the leaf remover.
5. Before and while working, do not drink alcohol, take drugs, or any other substances which may alter your capability of working with machine tools.
6. Do not use the leaf remover under unsafe conditions. For instance, it is forbidden to execute makeshift repair activities just to start working. Operate only in daylight or good artificial light.
7. Be sure to have sufficient fuel, to prevent a forced stopping of the leaf remover, maybe during a critical movement.
8. Ensure that all safety shielding and safety signs are properly installed and in good condition.
9. Never operate the leaf remover without all shields in place and in good operational condition.
10. The operator must be familiar with the leaf remover and tractor and all associated safety practices before operating the leaf remover and tractor.

**IMPORTANT:** Always use the supplied anti-noise safety ear protector when operating the Leaf Remover.

Also, anyone within a radius of 50 feet (15 meters) should wear ear protection.

## 2.6 OPERATIONAL SAFETY

### WHEN WORKING OR DURING THE MAINTENANCE ACTIVITIES IT IS NECESSARY TO REMEMBER:

The use of this equipment is subject to certain hazards that cannot be protected against by the mechanical means or product design. All operators of this equipment must read and understand this entire manual, paying particular attention to safety and operating instructions, prior to using. If there is something in this manual you do not understand, ask your supervisor, or your dealer, to explain it to you.

Most accidents occur because of neglect or carelessness. Keep all helpers and bystanders at least several hundred feet from an operating leaf remover. Only properly trained people should operate this machine. ***Operation must be stopped when anyone comes within several hundred feet.***

The labels and stickers providing instructions and pointing out the dangers, must not be removed, hidden, or made illegible.

Do not remove, except in case of maintenance, the shields, guards, and deflectors equipped on the leaf remover. When it is necessary to remove them, stop engine, handle with care and reassemble them properly before restarting the engine and using the equipment.

All shields, guards, and deflectors equipped on the leaf remover must be maintained in good operational condition.

**IMPORTANT:** The serial number plate identifying the type of machine and serial number must never be removed from the machine.

It is forbidden to lubricate, clean and adjust the moving parts while they are running.

During maintenance or adjustment activities on the equipment it is forbidden to use hands for executing operations for which there are specific tools.

Do not use tools in bad condition or inappropriately, for instance pliers rather than wrenches.

When maintenance or repairs are completed check out that no tools, wiping rags, or other materials are left inside spaces or guides with moving parts.

While using the equipment, it is forbidden to make more than one person give directions and make signals. The eventual directions and signals relating to the load handling must be given by one person only.

Do not unexpectedly call an operator while he is working if not necessary; it is forbidden as well to frighten or throw objects at the operator, even if just for fun.

Watch out for those who are present, especially the children! Do not let people get on the machine.

When not in use, stop the vehicle's engine, park it on flat ground with parking brake engaged and the PTO disengaged. Never leave equipment unattended with the tractor running.

Do not clean, lubricate, repair or adjust with the engine running and the machine lifted.

Do not allow riders on the leaf remover or tractor at any time. There is no safe place for any riders. Do not operate unless all personnel, livestock, and pets are several hundred feet away.

Never use the machine on steep slopes which may jeopardize the equipment's stability. Avoid sudden changes of direction.

When transporting adapt your speed and driving style to the laws of the road. Be extremely watchful and careful when transporting on roads.

***The manufacturer declines all responsibility for a lack of compliance with these instructions.***

# 3 ASSEMBLY

## 3.1 MOUNTING LEAF REMOVER TO THE TRACTOR

To aid in the front mounting of the Leaf Remover to your tractor we provide the following items:

- A** - A universal double pocket mounting bracket for the front of the tractor.
- B** - Two back braces with a tubing inside of a tubing assembly. One end attaches to the top mast of the main frame. The other end attaches to the frame of the tractor. After bolting in place, it will require welding the tubing together.
- C** - This storage stand is standard equipment with the Leaf Remover. This makes for an easy, safety system for storing the unit.

Once the leaf remover has been placed to the desired position with the provided universal double pocket bracket (**A**) bolted to the leaf remover, clamp this assembly in place per your requirements.

The mounting bracket that must be made is the spacer plate that fits between bracket and the front of the tractor. The thickness of bracket will vary depending on how much clearance is required to safely clear the grill of the tractor.

The back brace rods (**B**) ensure strong stability of the leaf remover to the tractor. These rods are bolted to the leaf remover brackets as shown (**C**).

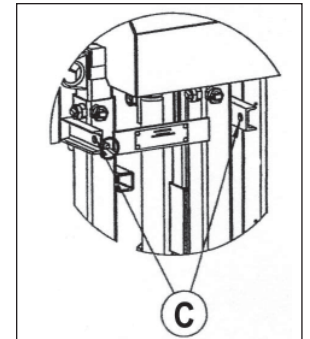
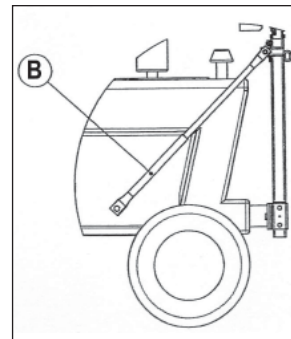
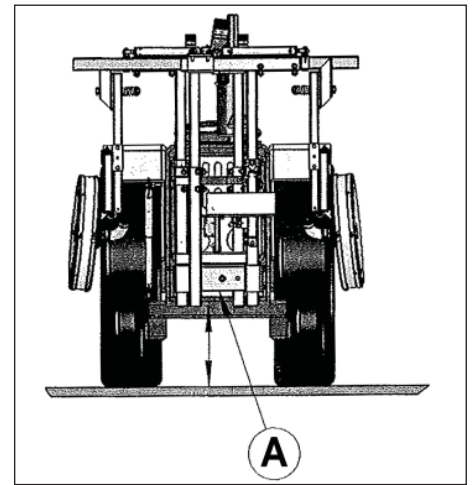
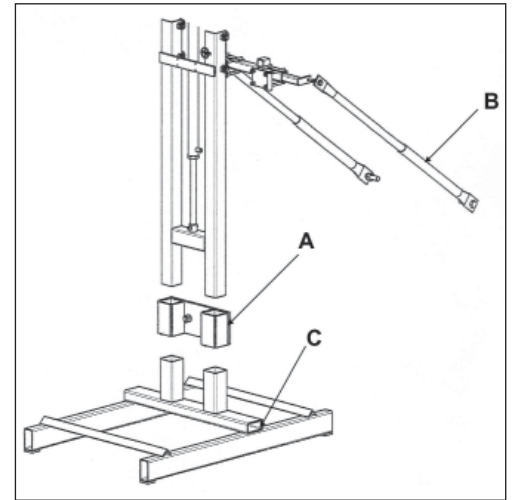

## 3.2 INSTALLATION

The leaf remover is mounted on the front of an inter row tractor.

The electric controls distributor (C) is generally positioned in front of the machine (See **fig. 1**). However, it can be positioned at the back (between the frame of the machine and the tractor) (See **fig. 2**). This positioning is not recommended because the proximity of the engine of the tractor can involve overheating. To change the position of the electric controls distributor, unscrew the screw (D) and place the electric controls distributor on the desired side, then tighten the screw (D).

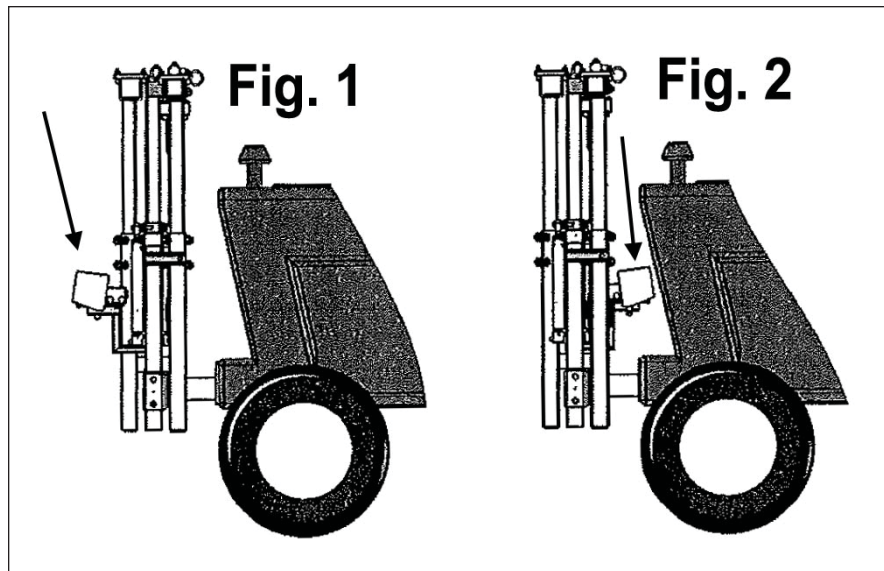
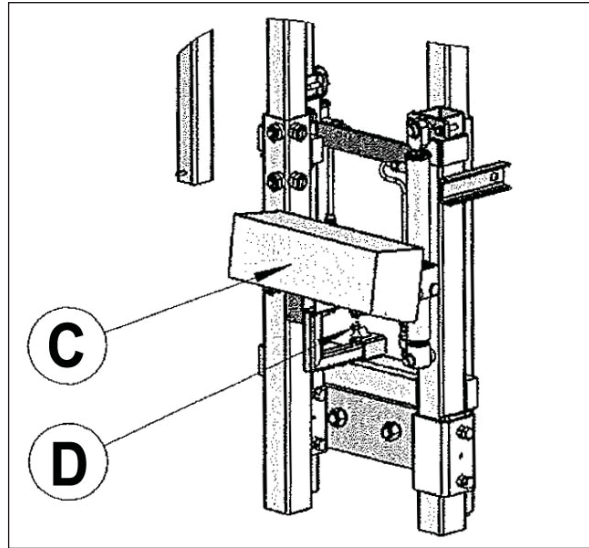



### 3.3 FINAL ASSEMBLY

In order to ensure the correct mounting of the trimmer to the tractor, please follow closely the following instructions:

- Angle (**A**) should be no more than 45 degrees
- Length (**L1**) should be as short as possible
- Distance (**L2**) should be as long as possible
- Height (**H**) should be as high as possible

After bolting the 2 piece back brace rods in place, weld the inner and outer tubes together.

**NOTE:** *After assembly, make sure that the tractor/leaf remover mounting is strong enough to give years of trouble free service.*

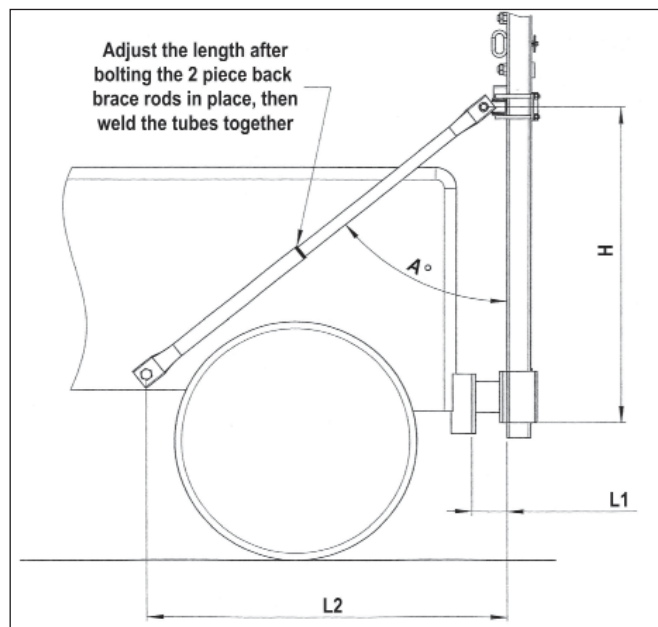

#### MOUNTING LEAF REMOVER TO CRAWLER TRACTORS

Collard does not recommend mounting their Leaf Remover to crawler tractors due to severe vibrations.

However, if you elect to mount our unit to a crawler, please follow closely the following instructions:

1. Daily you should check all hardware for tightness.  
*Note: If bolts come loose it could cause damage to the leaf remover and potential safety to the operator.*
2. Make sure to mount an extra strong bracket between the tractor and the Leaf Remover, as it must be able to withstand violent forces.
3. Make sure the back braces from the Leaf Remover to the crawler have strong anchor points.

## 4 DEFOLIATOR

### 4.1 VARIOUS USES OF THE COLLARD DEFOLIATOR

1. Defoliation at setting of the fruit is the time to direct the air into the fruit zone because the small berries are well spaced and quite tough. This is the best time to remove caps and clean the bunches. In these conditions, the defoliation on sunrise side is recommended.
2. Defoliation can be used in the VERAISON, either on the sunrise side or both sides. Please pay attention to the risk of burning berries.
3. Defoliation can be used in the case of manual picking. This leaf removal saves time for the picker, thanks to the excellent visibility of the clusters.

#### **FUNCTIONING**

- Defoliation is produced by a double stream of air jets at a low pressure.
- Produced by the air compressor, the air jets pass by the foliage on the level of the fruit zone through the rotary nozzles.
- The rapid pulses of low pressure (15 P.S.I.) air shakes the leaves from the foliage around the clusters.
- The nozzles are protected by a stainless steel cover, that also avoids contact with the clusters.

#### **REQUIREMENTS**

- The air compressor is 3-point hitch mounted, 540 R.P.M.
- The tractor requirements is 60 H.P. minimum with hydraulic capacity of 8 G.P.M. at 2400 PSI.

### 4.2 TWIN ROTORS DEFOLIATING HEADS

The defoliating heads are designed to turn to three different positions to meet the conditions for different vineyard requirements. This adjustment allows for adjustable heights of defoliation.

#### **POSITIONING THE DEFOLIATING HEADS:**

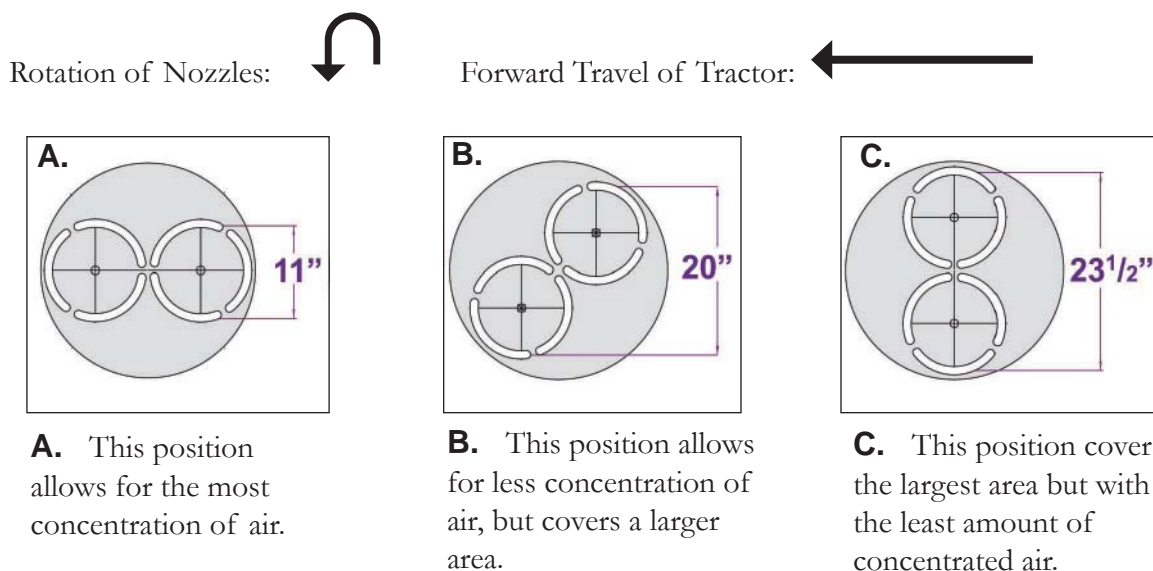

## 4.3 DEFOLIATION FROM THE TOP

### **DEFOLIATED ZONE**

In this situation, the defoliating head is tilted and enters the foliage slightly over the grapes and removes leaves inside of the vegetation.

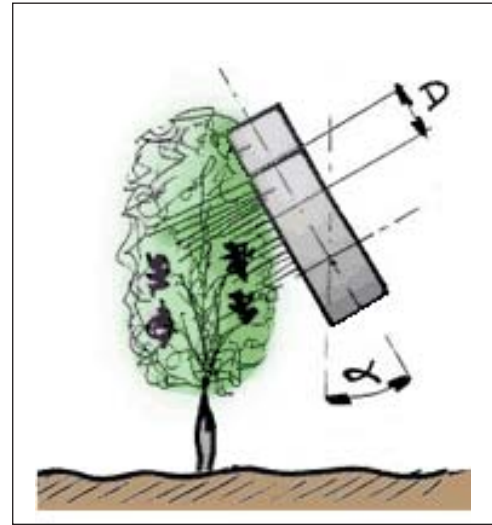

This kind of defoliation can also be practiced for manual grape harvests, the picker sees and cuts the grapes by top with less effort and better visibility.

### **DEFOLIATION AT SETTING**

In this situation, the head is vertical. The passage of the air jets is done at the level of the clusters. It gets a great case for said "Harvest in Green" that consists to eliminate some number of clusters to production and control improvement of the quality.

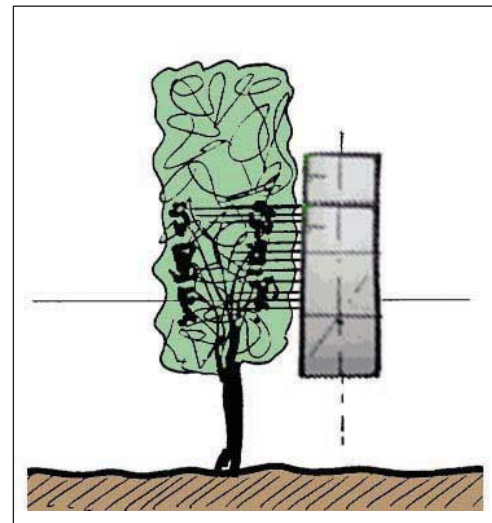

### **DEFOLIATION IN "FREE" VINES**

In this situation, the element will be tilted downward, air jets blow upward. It clears the grapes without removing too many leaves on side.

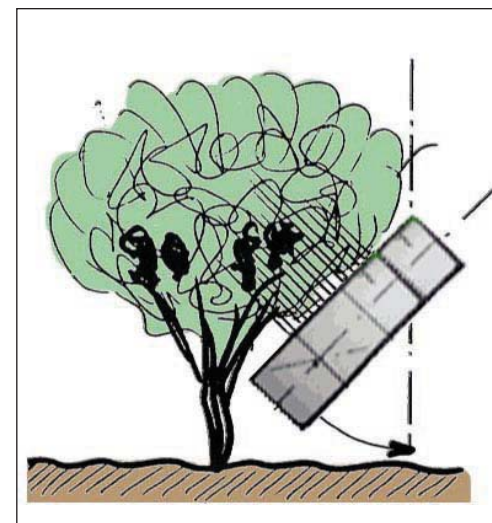

## 5 OPERATION

### 5.1 STARTING THE LEAF REMOVER

- Connect the quick couplers to the tractor hydraulics. Make sure the JIC couplers are clean and fit perfectly.
- On the electric control box, adjust the regulator of the nozzle speed to 0.
- Start the engine of the tractor and let it run on idle.
- Engage the tractor PTO, but run the air compressor only at idle.
- On the electric control box, turn the speed regulator to obtain a low speed rotation of the nozzles.
- Operate the machine at the low speed for about 5 minutes to ensure the pre-heating is sufficient.
- Then increase the PTO speed to the tractors' engine speed to reach the 540 P.T.O., so noted on the tractor RPM dial.
- When the maximum speed is reached, check to make sure the safety relief valve is open and if the air is being released from the compressor.
- You can check the free sliding movement of the safety valve with a screwdriver. (*Picture No. 17*).

The above operations do not take much time and greatly increases the life of the machine.

When the Leaf Remover is operating, the speed of the air compressor must be adjusted to obtain sufficient air flow thus ensuring optimal quality leaf removing. (*See table below*).

PTO	Gearbox Speed-up	Air Compressor - Maximum Speed
540 R.P.M.	7/1 Ratio	3780 R.P.M.

**Picture No. 17**

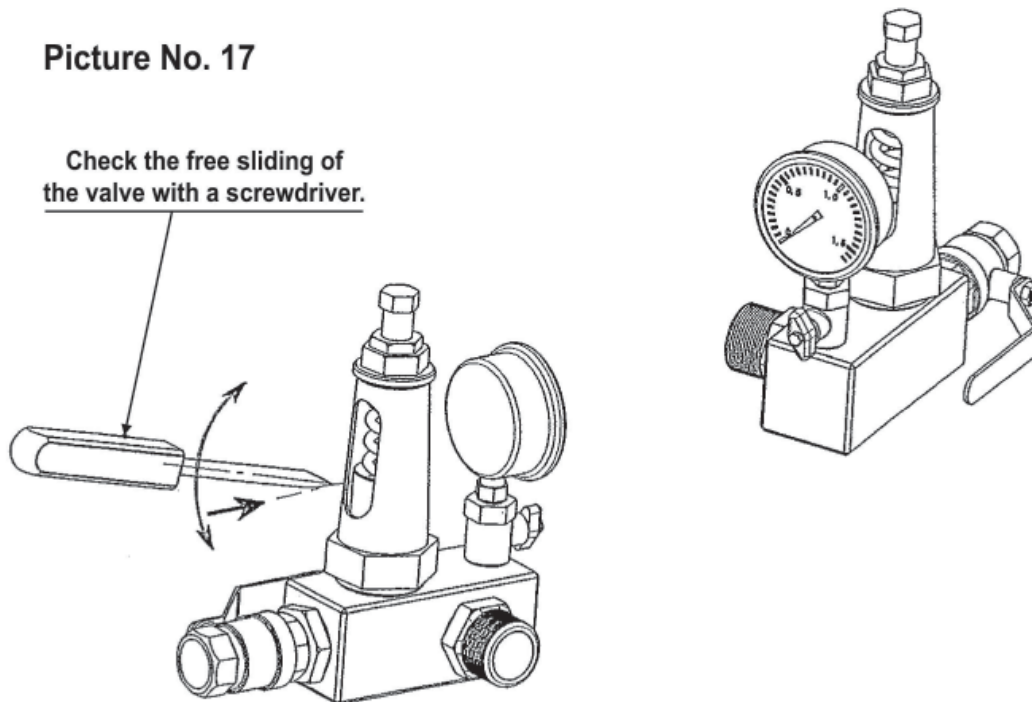

## 5.2 ADJUSTMENTS OF THE LEAF REMOVERS

The following chart shows the theoretic values of the Leaf Removers. Depending on the tractor, thickness of the foliage, and other conditions, the user may have to make adjustments in order to improve the operation. **However, do not increase the speed rotation of the twin rotors over 900 R.P.M.**

To regulate the air pressure:

- ~ Adjust the speed rotation of the PTO until obtaining the desired pressure.
- ~ **OR** open/close gradually the valve until obtaining the desired pressure.

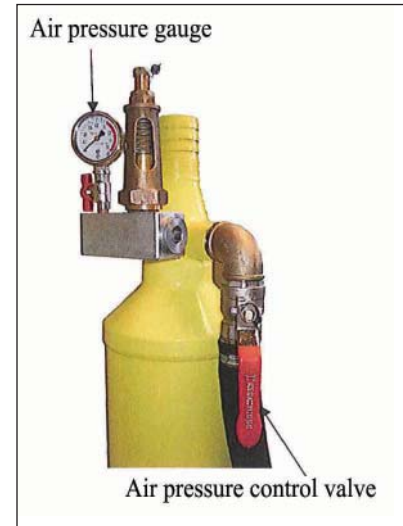

**The air pressure should NEVER exceed 14.5 P.S.I.**

This would reduce the life of the air compressor.

**Do not exceed the maximum speed rotation of the air distributors.**

Leaf Remover	Twin-Rotor
<b><u>Maximum</u></b> speed rotation of nozzles:	900 R.P.M.
Air Compressor speed rotation (model #NX3):	3780 R.P.M. at 540 R.P.M. PSI
Air pressure adjustment range:	3 to 13 PSI
Nozzle size in mm:	14 mm after blossoming 12 mm before harvest

## 5.3 CALIBRATING THE NOZZLES RPM SPEED

The Leaf Remover is adjusted at the factory, however due to varying tractor oil flow, it will be necessary to re-calibrate. When performing this operation, make sure the nozzle speed rotation does not exceed 900 R.P.M.'s.

To calibrate the flow this operation will require two people.

The necessary tools are:

- 1 - Screwdriver
- 1 - Revolution counter (tachometer)

### OPERATING PROCEDURE:

1. Make all connections between the tractor and the Leaf Remover (including hydraulic, electrical and PTO shaft connections)

### CAUTION: Do Not start the machine

2. On the electric box (A), turn the switch to “on” (1) to R/H.
3. Remove the 4 screws (a) on the cover of the electric box (2).
4. Locate the three terminal resistor (B) in the electric box (A). Loosen screw (3) and turn the stem (4) to the L/H.
5. Engage the tractor PTO and hydraulics.
6. Turn the stem (4) very slowly to the R/H until the nozzles (6) rotate.
7. Verify the rotation speed with a tachometer by placing it in either of the two holes shown as number (5) in the face of the Defoliation Head (C).
8. Turn the stem (4) to the maximum allowed rotation speed of 900 R.P.M.
9. Tighten the knob screw (3) on the resistor (B).
10. Close cover (2) on electric box (A).

The calibration of the flow is finished, you can now regulate the speed rotation of the nozzles by activating the graduated button in frontage from 0 to 10.

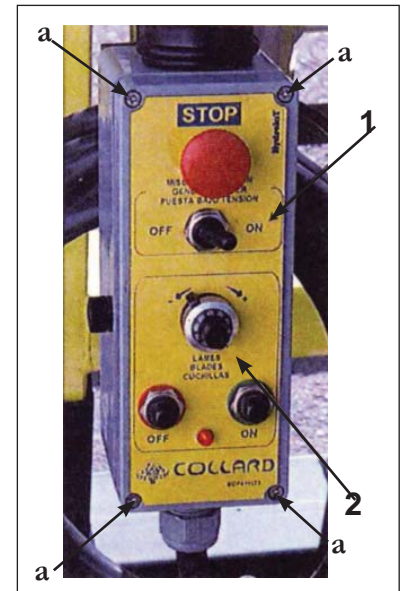

Picture A

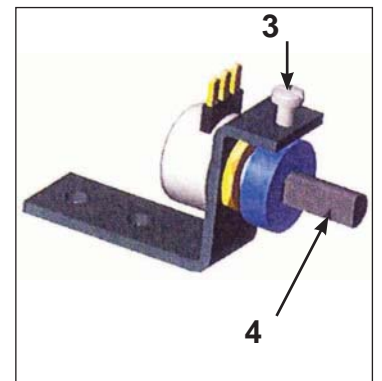

Picture B

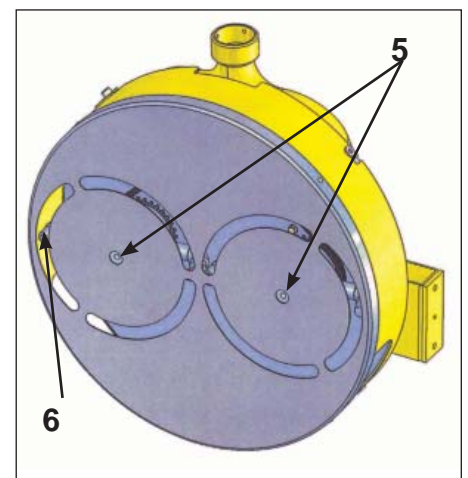

Picture C

## 5.4 HYDRAULIC CYLINDER ADJUSTMENT

Depending on the flow of the tractor hydraulics and temperature of the oil, the speed of cylinders can change.

If the movements are too fast or too slow, a device on the end of the cylinders allows for "fine" adjustment.

To adjust cylinder speed:

1. Remove cap nut (4)
2. Loosen the jam nut (1)
3. Turn screw (2) until you obtain the desired speed

When desired speed is obtained:

4. Tighten the jam nut (1) making sure washer (3) is in place
5. Reinstall cap nut (4).

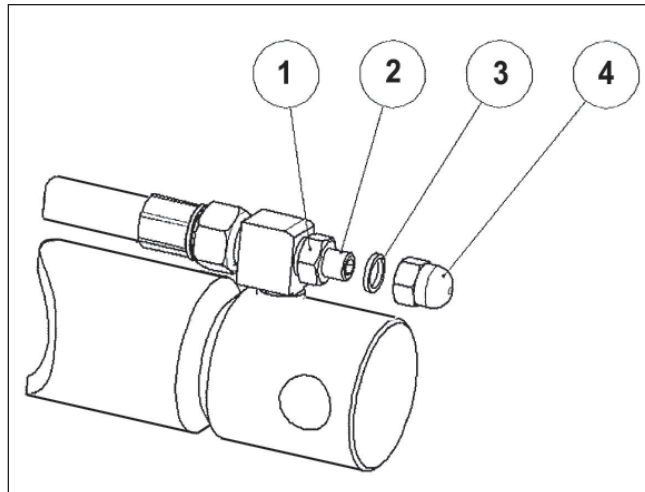

## 5.5 SEEPAGE ON "NX" AIR COMPRESSOR

The Collard Leaf Remover features the high quality "NX" air compressors. This air compressor was designed to allow slight seepage through the 3 venting caps (b).

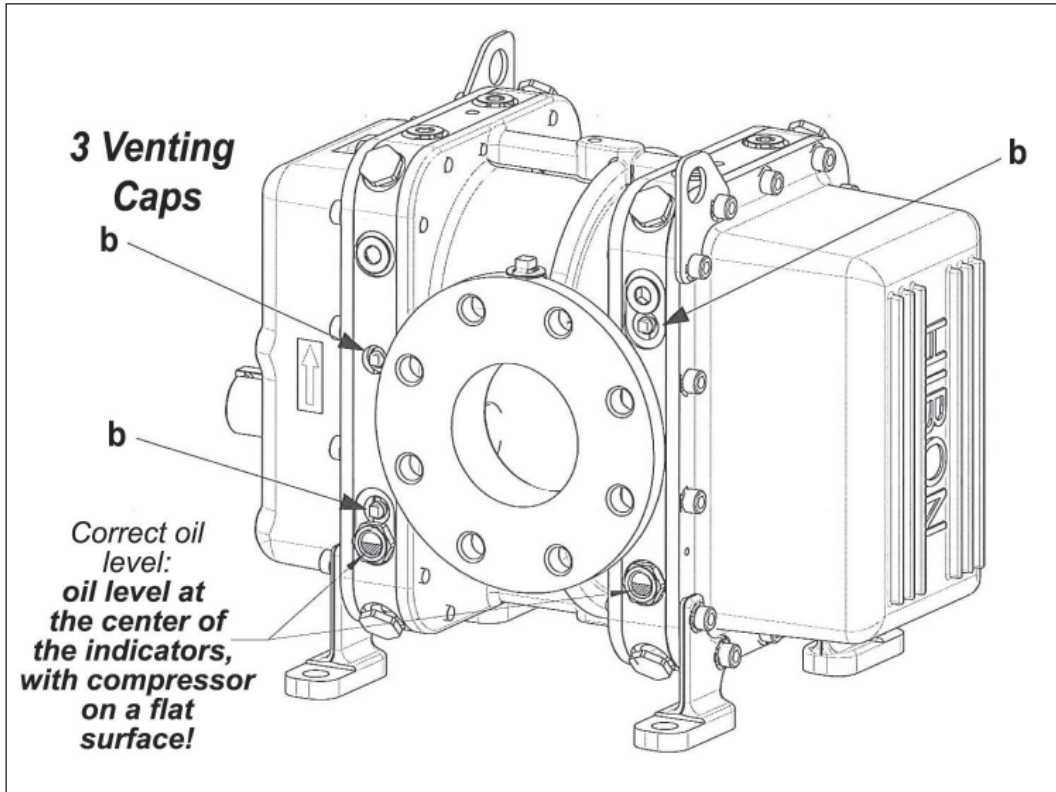

**CAUTION:** Never over fill the air compressor. Always add oil just to the center of the oil sight gauge.

The seepage also causes accumulation of dust and dirt on the compressor. Please clean the unit regularly to keep it in good working condition.



# 6 MAINTENANCE

## 6.1 MAINTENANCE OF "NX" AIR COMPRESSOR

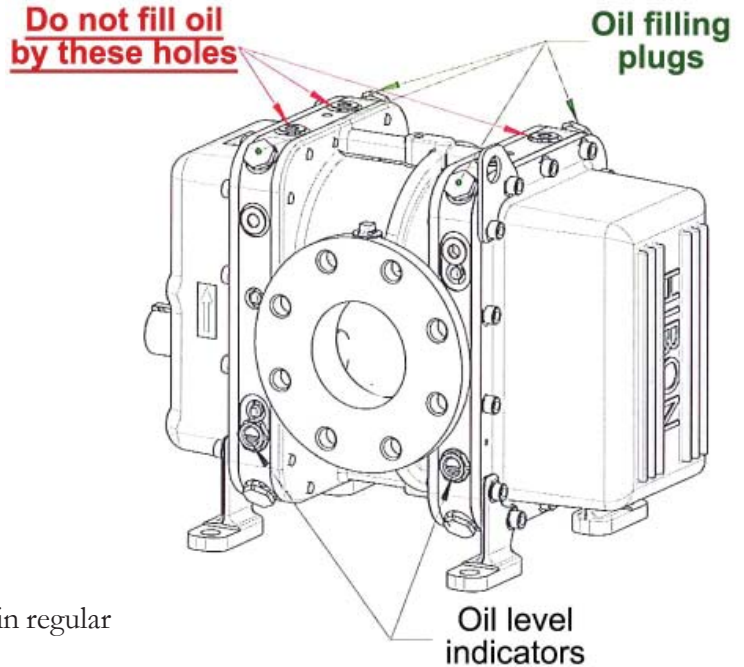
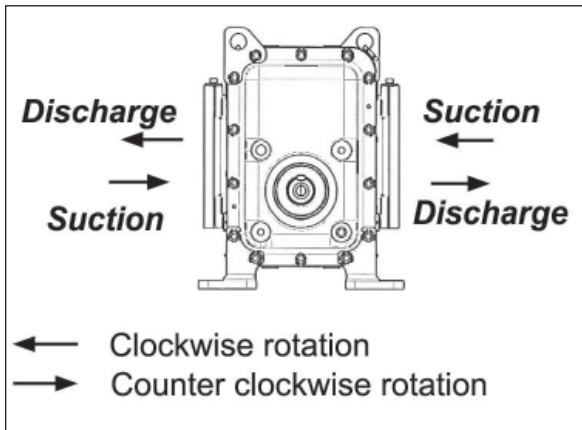

### **FREQUENCY OF DRAINING:**

The maintenance of the machine consists mostly in regular checking of the oil level and draining.

During each draining operation, the filling and draining plugs have to be cleaned and the seals have to be replaced. Clean also the oil level indicators.

- The first draining has to be done after **200 hours** of operation
- Each year, it is necessary to do a draining before starting the machine, whatever the number of operating hours
- At the end of the season, it is necessary to do a draining before storing

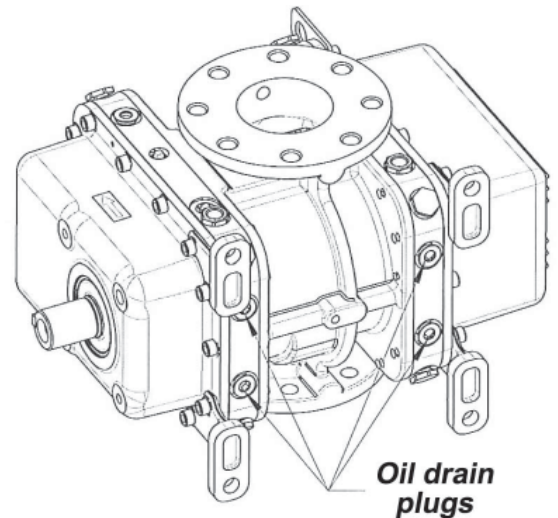

### **CHECKING OF THE OIL LEVEL:**

Check the oil level before each operation of the machine. The level is correct when you see it at the middle of the indicator. This checking is only to be done when the machine is stopped and horizontal.

**OIL TYPE: SH 220 or equal**



## 6.2 MAINTENANCE OF GEARBOX

### GEARBOX 7/1 RATIO

Part Number: 0502 1347

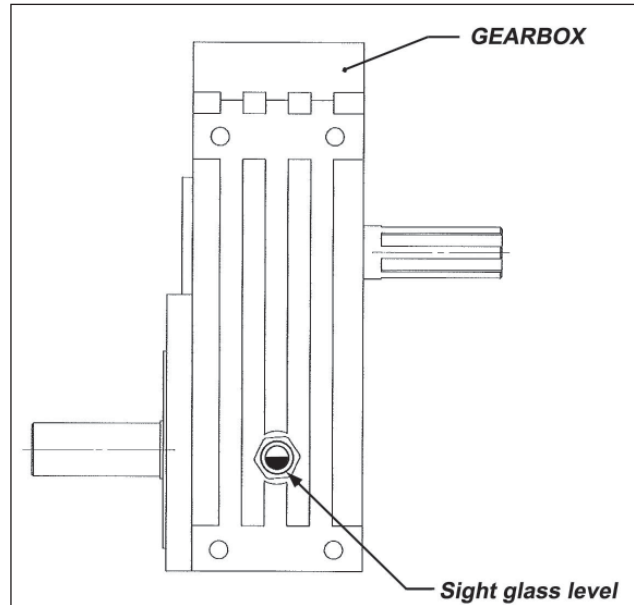

#### Oil Level:

The level is correct when it is at the middle of the sight glass.

**Type of Oil:** SH220 or equal

## 6.3 FLEX COUPLING

Check that the rubber coupling is in place, with all the bolts in place.

Also, check if all bolts are correctly tightened and that the hubs are also in place and clamped on the driveshafts.

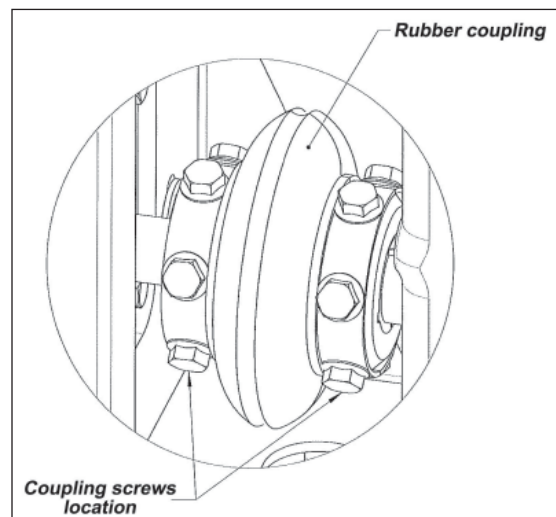

#### Hoses:

The air comes from the air compressor to the nozzles through rubber air hoses. Check if all hoses are perfectly air proof.

The leaf remover works with compressed air; any leakage of air (even if it is a small leak) decreases the efficiency of the machine. In case of leakage on the hose, **it has to be replaced.**

## 6.3 FLEX COUPLING (CONTINUED)

### **FLEX COUPLING:**

The Flex Coupling is installed at the factory. The mounted position is between the gearbox and air compressor.

If it becomes necessary to replace the flex coupling, please follow the steps 1 to 3.

#### **WARNING:**

The incorrect mounting of the Flex Coupler could cause serious injury.

### **MOUNTING:**

#### **Step 1:**

- Check the shafts and the bores of each one of the 2 hubs, be sure that they are clean.
- Check the good fit of the keys on the shafts.
- Install the 2 hubs on the shafts; one of both has to be loosened in order to adjust the distance by using a half shell as reference.
- Tighten correctly the hubs on the shafts.

#### **Step 2:**

- Position a half shell all around the hubs and fix it to the provided fastening bolts.
- It is important to rigorously respect the instructions concerning the fixing of the fastening bolts.
- Torque the bolts to 40 ft/lbs.

#### **Step 3:**

- Turn the shaft 180° and install the second half shell with the bolts.
- Torque the bolts to 40 ft/lbs.

The replacement of the flex coupler does not require moving the hubs or to realign the connected equipment.

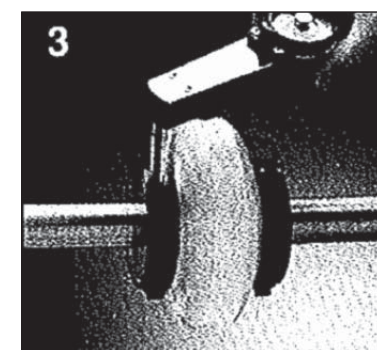
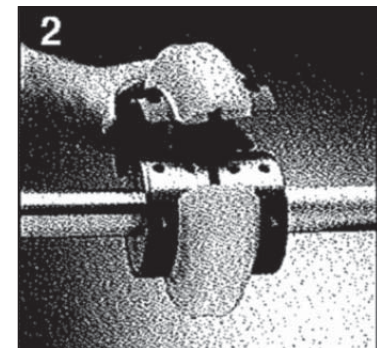
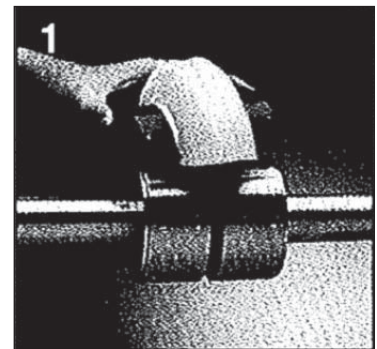

### ADJUSTMENTS:

The operating speed must be chosen according to:

- The density of vegetation
- The density of the grapes (the working speed can be more important when there are many grape clusters, indeed the leaf removing in that case is more efficient)
- The selected gear on the tractor gearbox
- The most effective tractor speed is usually about 2 ½ miles per hour.

### DAILY MAINTENANCE OF THE LEAF REMOVER:

- Check the air compressor and gearbox oil levels.
- Daily take off the stainless cover of the defoliation heads and remove any debris that may have accumulated.
- At that time check the nozzle drive chain tension, adjust with slight tension.
- Clean daily the air filter on the suction side of the air compressor.

**WARNING:**

A 20% clogged filter requires approximately 20% additional power at the air compressor. This blockage leads to overheating of the compressed air and might quickly cause damage to the air compressor.

**IMPORTANT:**

Check and be sure there is no air leakage all along the air system from the air compressor up to the nozzles. To do that, start the tractor, maintain throttle on idle, stop the rotation of the nozzles, remove the defoliating head cover(s) and check for any air leaks. If not, stop the engine, put the cover(s) in its place. An air leak decreases the defoliation quality.

**IMPORTANT:**

**NEVER** perform maintenance or service on the defoliation heads without stopping the tractor's engine, thus stopping the rotating nozzles.

### CONTROLS ON THE TRACTOR BEFORE STARTING WORK:

*Before operation* - Due to particles and dust produced by this leaf removing operation it would be preferable to change the engine oil as well as air and diesel filters. At the same time, check the level of the hydraulic system.

The tractor engine must be clear of debris, thus as often as possible:

1. Clean the engine air filter
2. Clean the engine oil radiator
3. Clean the radiator's grill

## 6.6 OFF SEASON STORAGE AND HANDLING

All machines working on a seasonal basis require a minimum of care before being stored:

### AIR COMPRESSOR:

- Disassemble the exhaust booster.
- Remove on the opposite side the aspiration filter and clean.
- Remove the silencer and the rubber hoses.

They should be coated with talc in order to protect them from humidity.

They should be stored in a dry place (between 40° to 70°) and without too much light.

Clean the inside of the body of the rotors with a brush and a solvent (petroleum) and dry them with a rag.

Collect the solvent and impurities around the placed drain plug under the body.

With a rag, oil copiously the visible mobile parts of the compressor (turn them by hand with the coupling), the valve too.

Shut the air intake and air exhaust openings in order to be humidity proof during winter storage.

From time to time rotate the machine's shaft by hand (just a few turns every month).

### GEARBOX:

- Drain the oil.

## 6.7 BEFORE STARTING AFTER OFF SEASON

---

**A):** Clean the inside of the body and rotors of the air compressor with a solvent (petroleum).

**IMPORTANT:** Collect the solvent and impurities by the placed drain plug under the body.

**Be careful to not leave any impurities inside the compression chamber.**

**B):** Drain the crankcases of oil (imperative). Must be done annually.

**C):** Replace the oil in crankcases by means of special oil that we hold in stock regularly.

**ATTENTION:** Before putting back the clamp and the pipe rubber on compressor exhaust opening, turn the unit for 1 minute, approximately at 1500 R.P.M. in order to blow away the oil and the solvent which could still be there. Proceed then to the connection. It is dangerous to start the compressor outlet open. Sucking power by this opening is very powerful.

**WARNING:** Never place hands or any other objects near the suction side of the air compressor.

During the reassembly of accessories, verify that they are locked in place. Tighten all plugs.



### **SAFETY INSTRUCTIONS:**

- Do not work near noisy machines without suitable ear protection.
- Every machine in operation can be potentially dangerous.
- Do not operate the machine when the protection of coupling, lids or piping are dismantled (except for point no. 1).
- Do not remove the air filter when the compressor is functioning.
- Do not modify the position of the safety valve.

## 7 TROUBLESHOOTING

<b>PROBLEMS WHICH MAY OCCUR</b>			
<b>Problem</b>	<b>No.</b>	<b>Probable Cause</b>	<b>Checks - Remedies</b>
The compressor does not start or gets jammed:	1	The body is distorted by excessive stresses exerted by the air intake or exhaust pipe	Increase pressure to the recommended value or clean unit.
	2	A foreign matter has passed in the compressor.	Check the compressor.
	3	The compressor is contaminated.	Clean the compressor.
Abnormal running noise:	4	STOP immediately the unit.	Check the compressor.
The compressor heats abnormally:	5	Filter contaminated.	Clean or change the filter.
	6	Exit pressure is incorrect.	Check the wear of the valve.
	7	Oil level is too high.	Restore the normal oil level.
	8	The clearance between rotors or between rotors and compressor body is too large.	IMPORTANT: Wear, rebuild the compressor.
Leakages:	9	Oil leaks through the joint, between casings.	Restore the compressor.
	10	Oil leaks on oil level indicator.	Tighten or change the fitting.
	11	Oil level is too high.	Restore the normal oil level.
The air flow is too low:	12	Excessive depression.	Clean or change the filter.

# 8 LEAF REMOVER PARTS

LEAF REMOVER  
2 1/2 REVERSIBLE ROWS ON THE FRONT  
REF: 0422 0250

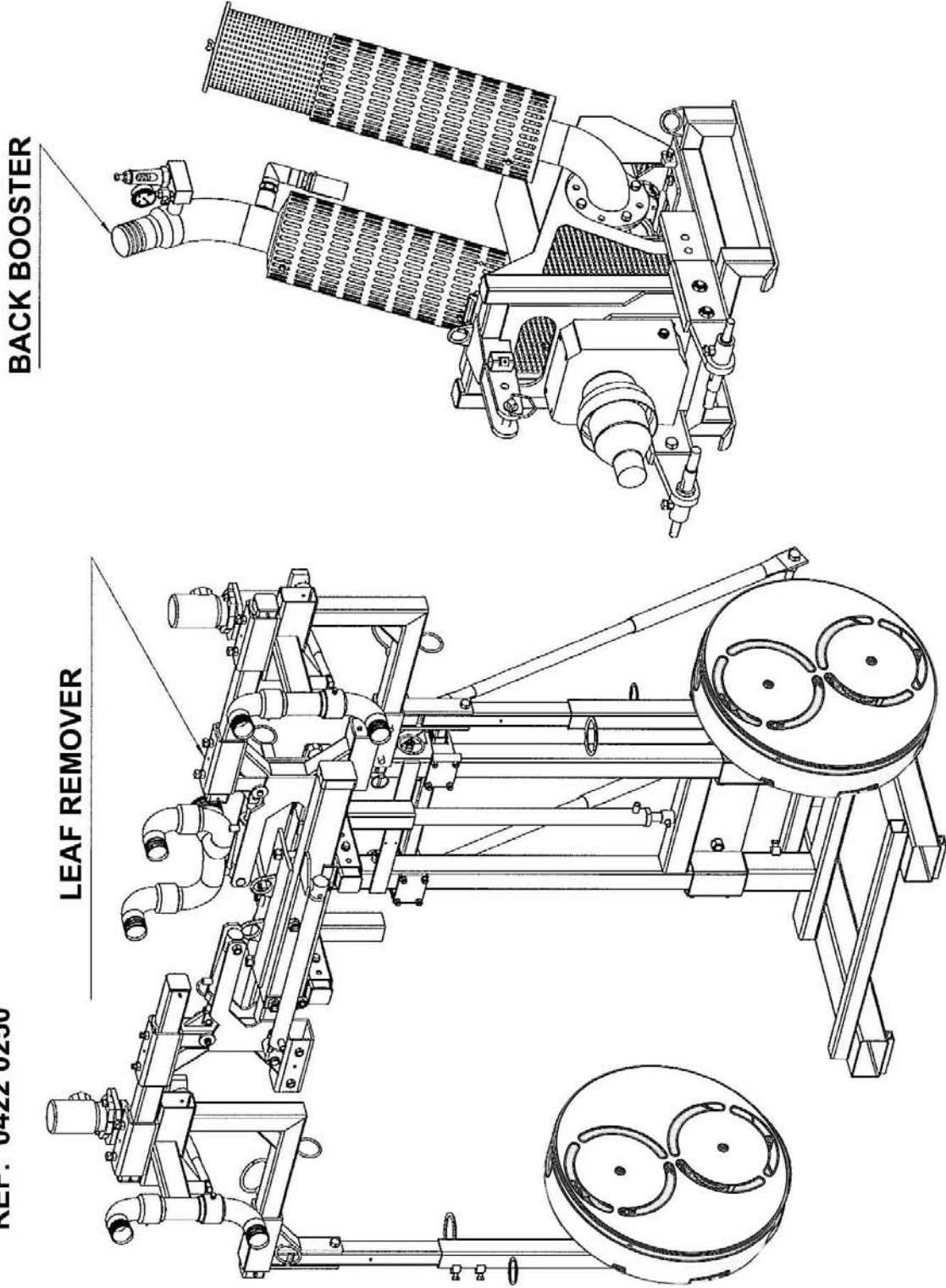



# 8 LEAF REMOVER PARTS (CONTINUED)

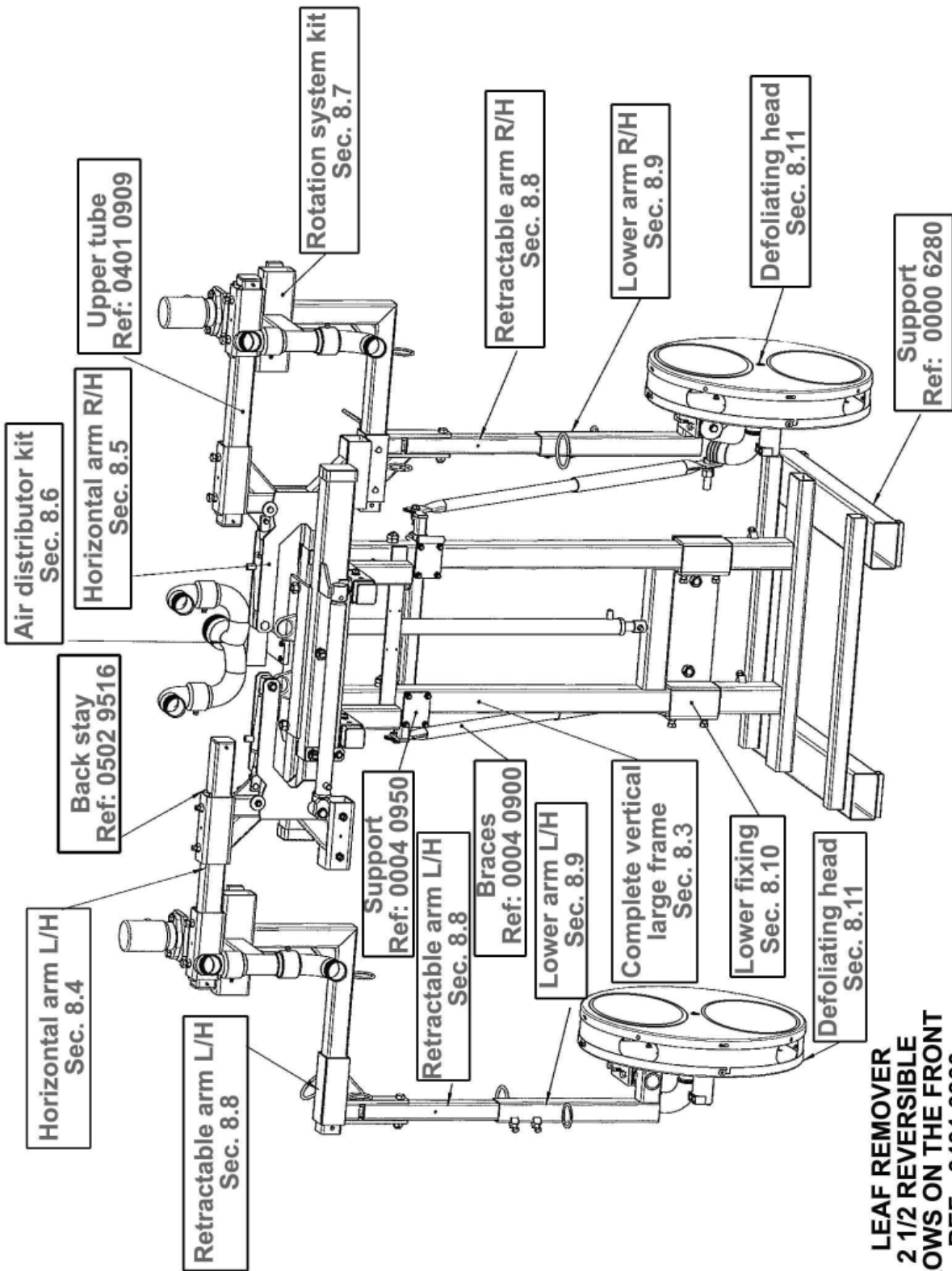

**LEAF REMOVER**  
**2 1/2 REVERSIBLE**  
**ROWS ON THE FRONT**  
**REF: 0401 0900**

# 8 LEAF REMOVER PARTS (CONTINUED)

## 8.1 ELECTRIC COMMAND E2200FR

PL 4012

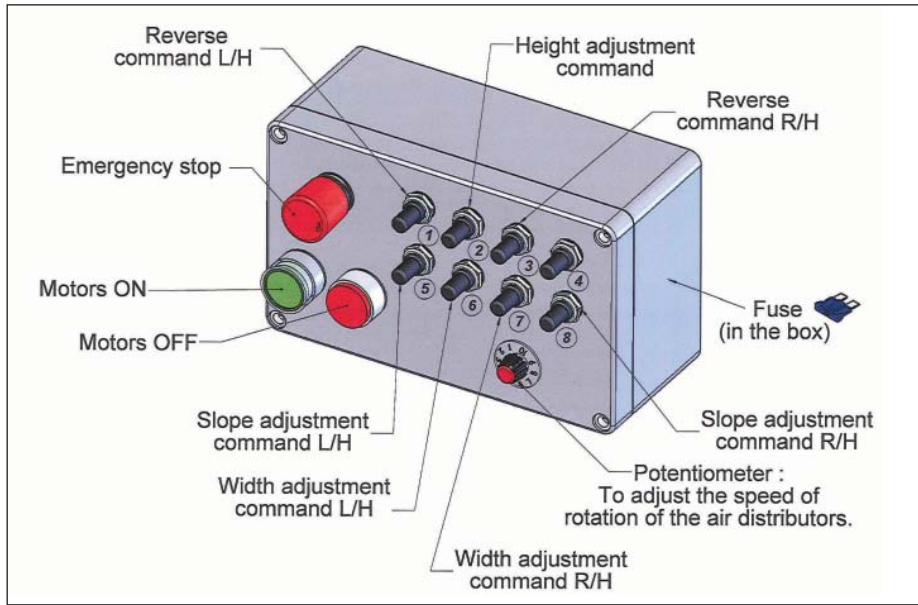

PL 5130

*Electric Control  
Ref. 00002464*

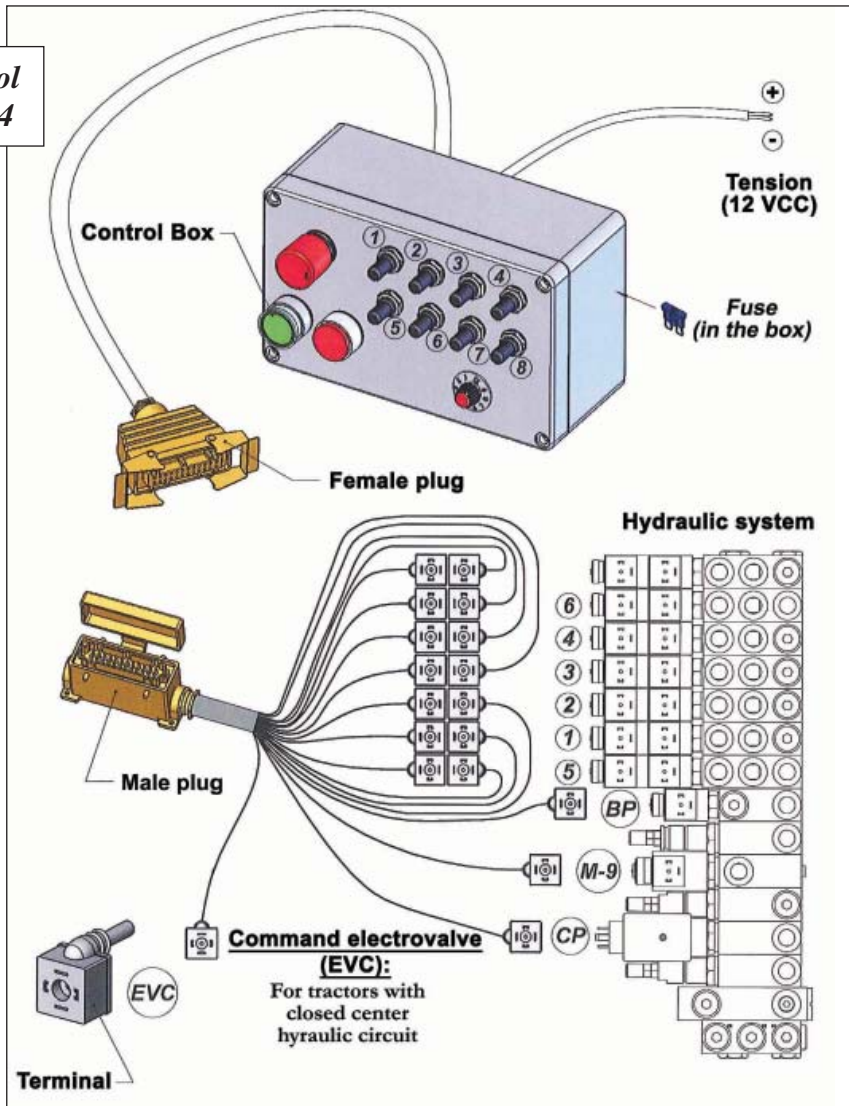

# 8 LEAF REMOVER PARTS (CONTINUED)

## 8.2 HYDRAULIC DIAGRAM (REF. KIT No. 0000 3072)

PL 3040

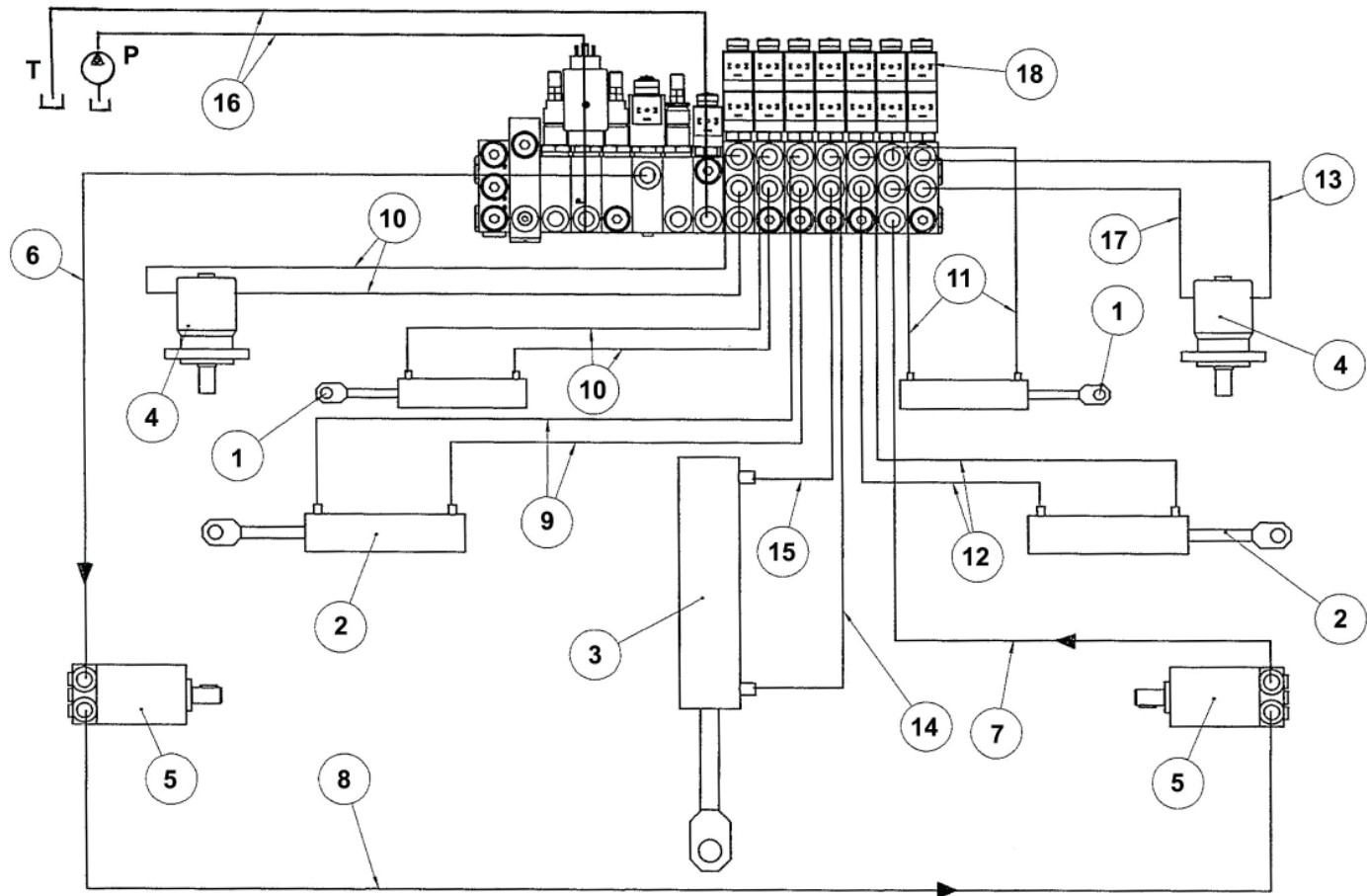

<u>REF.</u>	<u>QTY.</u>	<u>PART NO.</u>	<u>DESCRIPTION</u>	<u>PL NO.</u>
1	2	0501 9187	Cylinder DE 35 - 18	PL 1601 - Pg. 53
2	2	0501 9601	Cylinder DE 35 - 18	PL 1620 - Pg. 54
3	1	0501 9247	Cylinder DE 35 - 25	PL 1604 - Pg. 52
4	2	0502 1007	Motor 315 cm <sup>3</sup>	
5	2	0502 1054	Head Motor	
6	1	0503 5973	Hose Ø10 S-10 FJ 9/16 4.80m	
7	1	0503 5974	Hose Ø10 S-10 FJ 9/16 4.90m	
8	1	0503 5975	Hose Ø10 S-10 FJ 9/16 9.70m	
9	2	0503 5815	Hose Ø6 FJ 9/16 0.90m	
10	3	0503 5830	Hose Ø6 FJ 9/16 2.10m	
11	2	0503 5870	Hose Ø6 FJ 9/16 2.20m	
12	2	0503 5871	Hose Ø6 FJ 9/16 1.50m	
13	1	0503 5876	Hose Ø6 FJ 9/16 2.30m	
14	2	0503 5892	Hose Ø6 FJ 9/16 0.245m	
15	2	0503 5923	Hose Ø6 FJ 9/16 0.225m	
16	2	0503 7350	Hose Ø16 FJ 7/8 6.00m	
17	1	0503 5906	Hose E Ø6 FJ 9/16 2.25m	
18		0502 2957	Distributor 1 SE 7 DE	

# 8 LEAF REMOVER PARTS (CONTINUED)

## 8.3 HIGH LARGE VERTICAL FRAME UNIT (REF. 0052 8402)

PL 2259

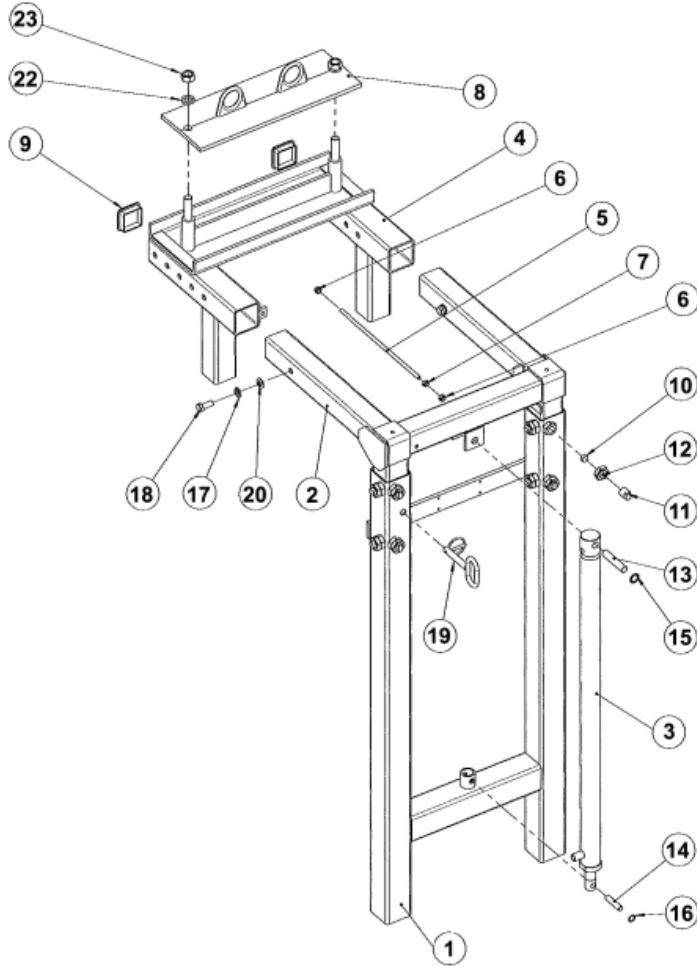

<u>REF.</u>	<u>QTY.</u>	<u>PART NO.</u>	<u>DESCRIPTION</u>	<u>ASSY.</u>
1	1	00528403	Female Large Frame High	
2	1	00528404	Male Large Frame High	
3	1	05019247	Cyl. DE 35-25 Stroke=800mm	PL 1604 - Pg. 52
4	1	00528405	Large Sliding Frame	
5	1	00528317	Threaded Rod M8 Zn	
6	2	05014306	Locknut M8	
7	1	05011206	Nut H M 8 Zn	
8	1	00528413	Attachment Wedge	
9	2	05017886	Cap For Tube 60 x 4	
10	8	05014309	Plastic Plug Ø16	
11	8	05010814	Screw M20	
12	8	05011208	Nut Hu M 20 Zn	
13	1	00480443	Axle Ø16	
14	1	00528325	Axle For Cylinder	
15	2	05014320	Washer Self Locking Ø16	
16	2	05014318	Washer Self Locking Ø12	
17	2	05015316	Washer W 12	
18	2	05010040	Screw TH M 12 x 30	
19	1	05016220	Pin Ø14	
20	2	05015019	Washer ZU 12	
21	1	05014050	Bolt Pin Ø6 Zn	
22	2	05015324	Washer W 18	
23	2	05011205	Nut M 18 Hu	

## 8 LEAF REMOVER PARTS (CONTINUED)

### 8.4 HORIZONTAL ARM L/H (REF. 0401 0938)

PL 2753

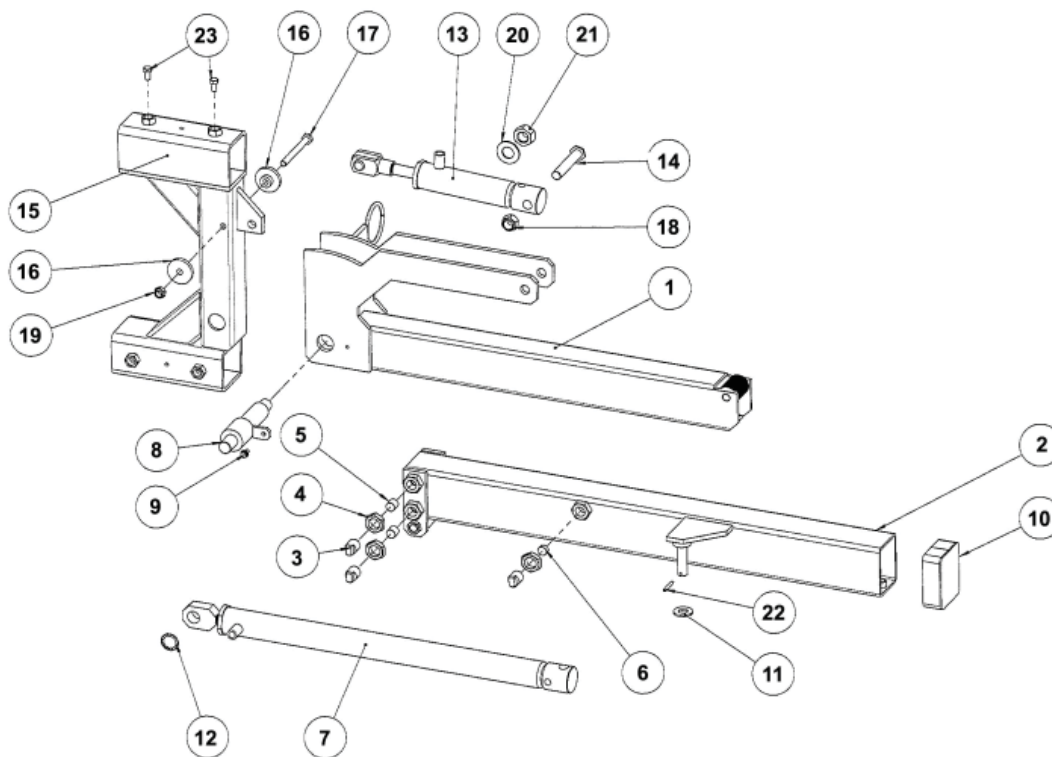

<u>REF.</u>	<u>QTY.</u>	<u>PART NO.</u>	<u>DESCRIPTION</u>	<u>ASSY.</u>
1	1	04010907Bis	Male Horizontal Tube	
2	1	00202108	Female Horizontal Tube	
3	3	05010814	Screw M20	
4	3	05011208	Nut Hu M20 Zn	
5	2	05014314	Plastic Plug Ø16	
6	1	05014309	Plastic Plug Ø16	
7	1	05019187-V3	Cylinder DE 35-18 / 500mm	PL 1601 - Pg. 53
8	1	00201326	Cylinder Link Axis	
9	1	05011851	Screw Tensilok M6 x 12 Zn	
10	1	00201332	Cover Plate	
11	1	05015016	Washer M16 Zn	
12	1	05014321	Washer Self Locking Ø22	
13	1	05019601	Cylinder DE 35-18 C=80 mm	PL 1620 - Pg. 54
14	1	00201341	Screw	
15	1	04010908	Fixation	
16	2	00201327	Holding Washer	
17	1	05010056	Screw TH M10 x 100 Zn	
18	1	05014307	Lock Nut M16	
19	1	05014311	Nut M10	
20	1	05015022	Washer M20 Zn	
21	1	05014301	Self Breaking Nut M20	
22	1	05014123	Elastic Pin Ø4 x 35 Zn	
23	2	05010149	Screw TH M8 x 16	

## 8 LEAF REMOVER PARTS (CONTINUED)

### 8.5 HORIZONTAL ARM R/H (REF. 0401 0939)

PL 2756

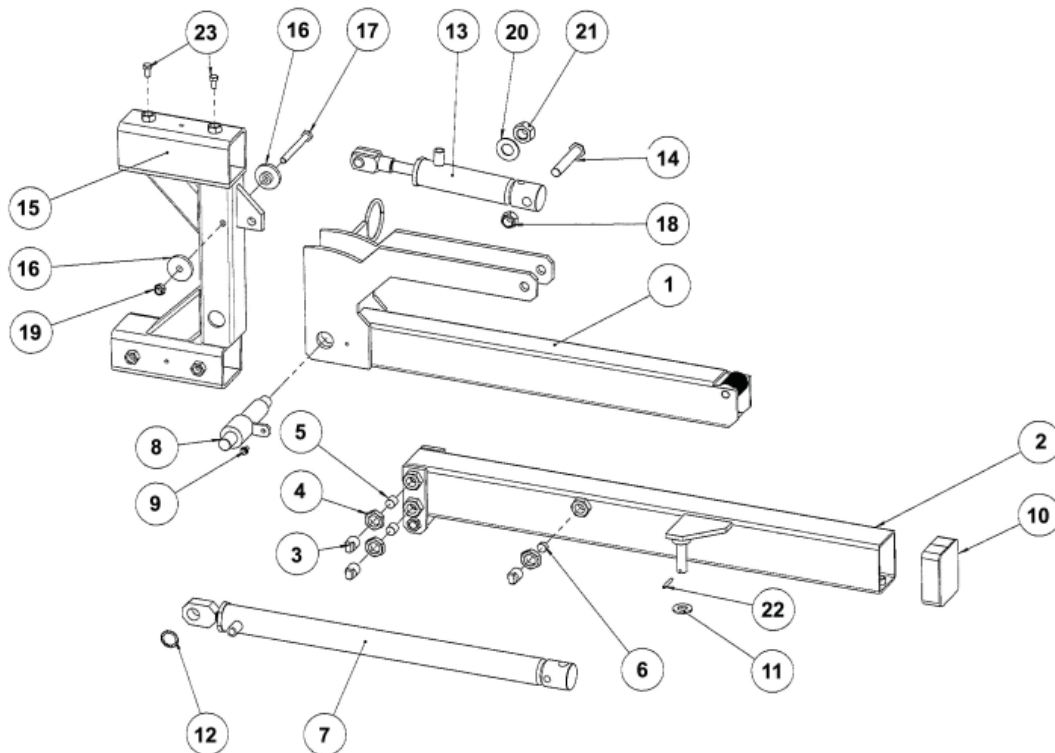

<u>REF.</u>	<u>QTY.</u>	<u>PART NO.</u>	<u>DESCRIPTION</u>	<u>ASSY.</u>
1	1	04010907Bis	Male Horizontal Tube	
2	1	00202108	Female Horizontal Tube	
3	3	05010814	Screw M20	
4	3	05011208	Nut Hu M20 Zn	
5	2	05014314	Plastic Plug Ø16	
6	1	05014309	Plastic Plug Ø16	
7	1	05019187-V3	Cylinder DE 35-18 / 500 mm	PL 1601 - Pg. 53
8	1	00201326	Cylinder Link Axis	
9	1	05011851	Screw Tensilok M6 x 12 Zn	
10	1	00201332	Cover Plate	
11	1	05015016	Washer M16 Zn	
12	1	05014321	Washer Self Locking Ø22	
13	1	05019601	Cylinder DE 35-18 C=80 mm	PL 1620 - Pg. 54
14	1	00201341	Screw	
15	1	04010908	Fixation	
16	2	00201327	Holding Washer	
17	1	05010056	Screw TH M10 x 100 Zn	
18	1	05014307	Lock Nut M16	
19	1	05014311	Nut M10	
20	1	05015022	Washer M20 Zn	
21	1	05014301	Self Breaking Nut M20	
22	1	05014123	Elastic Pin Ø4 x 35 Zn	
23	2	05010165	Screw TH M14 x 25	

## 8 LEAF REMOVER PARTS (CONTINUED)

### 8.6 AIR DISTRIBUTOR KIT (REF. 0401 3915)

PL 2801

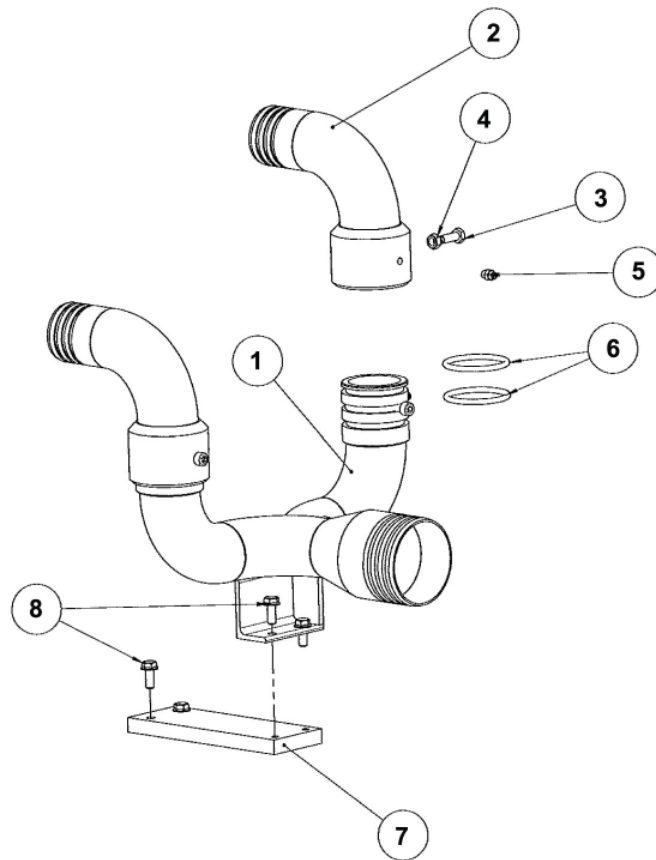

<u>REF.</u>	<u>QTY.</u>	<u>PART NO.</u>	<u>DESCRIPTION</u>
1	1	04010916	Air Dispatcher
2	2	04010911	Female Elbow
3	2	04010746	Screw
4	2	05011206	Nut H M 8 Zn
5	2	05016500	Greaser R/H M8
6	4	05001325	Joint R34
7	1	04013910	Air Dispatcher Support
8	4	05011866	Screw TH M8 x 20

# 8 LEAF REMOVER PARTS (CONTINUED)

## 8.7 REVERSIBLE SYSTEM KIT REF. 0401 0929

PL 2749

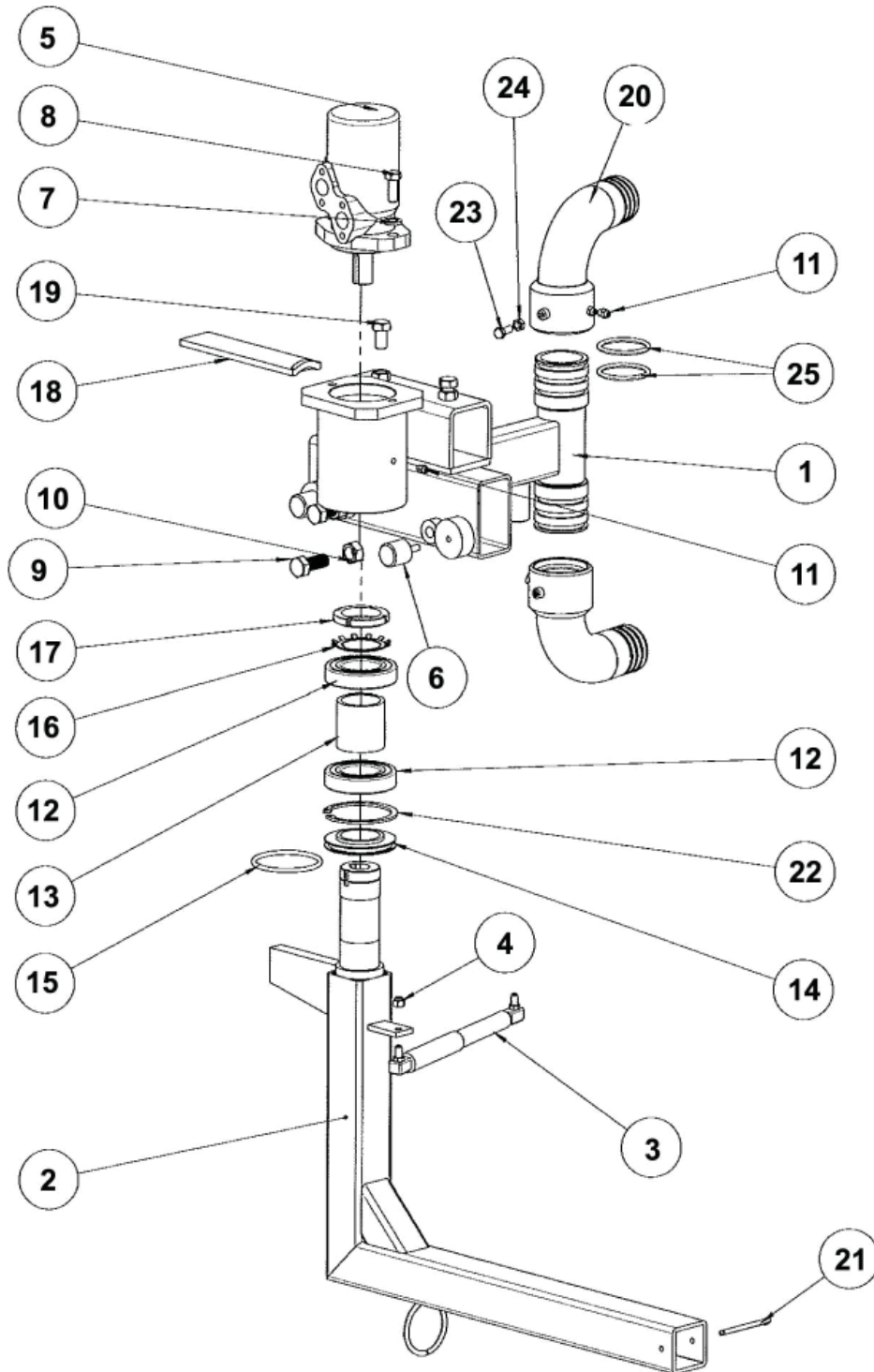



## 8 LEAF REMOVER PARTS (CONTINUED)

<u>REF.</u>	<u>QTY.</u>	<u>PART NO.</u>	<u>DESCRIPTION</u>
1	1	04010922	Rotation System
2	1	04010937	Rotation Arm
3	1	05016114	Gaz Cylinder
4	1	05014306	Threaded Rod M8 Zn
5	1	05021007	Motor 315 cc
6	2	05047715	Thrust
7	2	05015316	Washer W 12
8	2	05010156	Screw TH M12 x 30
9	2	05010051	Screw TH M16 x 35 Zn
10	2	05011201	Nut H M16 Zn
11	3	05016500	Right Greaser M8
12	2	05003038	Bearing (SKF)
13	1	05005392	Cross Bar
14	1	04011813	Ring
15	1	05001315	Joint R 41
16	1	05005252	Washer MB10
17	1	05005202	Nut KM 10
18	1	05029573	Clamping Wedge
19	2	05010165	Screw TH M14 x 25
20	2	04010911	Elbow
21	1	05014120	Pin V6 x 80
22	1	05013509	Elastic Ring Ø90 (inside)
23	2	04010746	Screw
24	2	05011206	Nut H M8 Zn
25	4	05001325	Joint R34

## 8 LEAF REMOVER PARTS (CONTINUED)

### 8.8 RETRACTABLE ARM R/H - L/H REF. 0401 0941 - 0401 0942

PL 2804

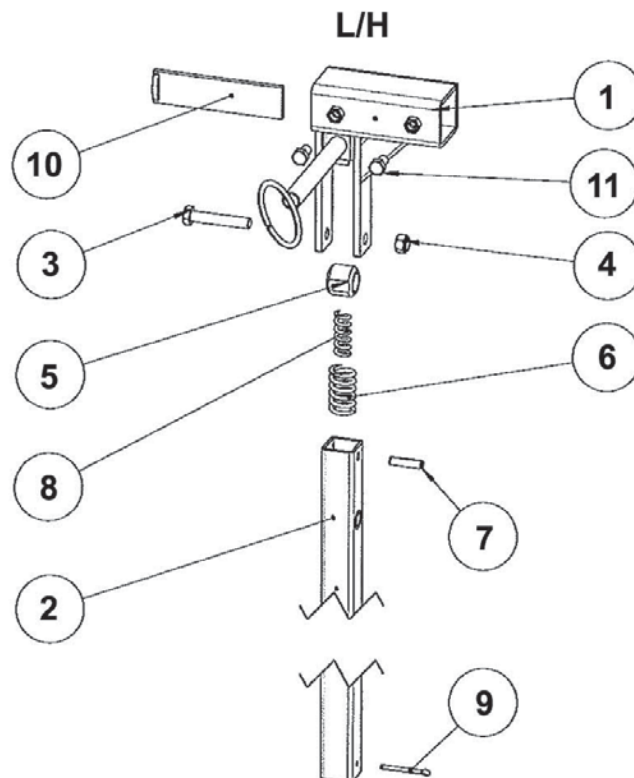
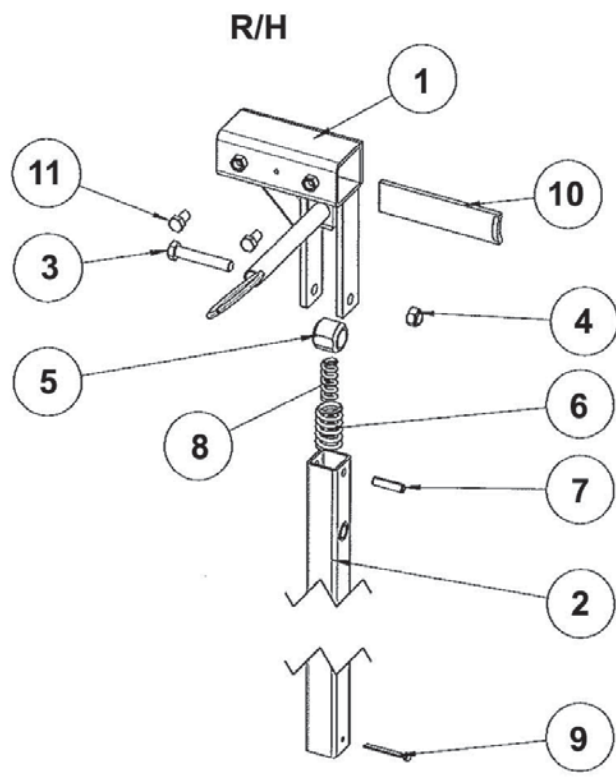

<u>REF.</u>	<u>QTY.</u>	<u>PART NO.</u>	<u>DESCRIPTION</u>
1	1	04010931	Fixation for Retractable System R/H
1	1	04010931bis	Fixation for Retractable System L/H
2	1	04010905	Intermediary Tube Retractable R/H & L/H
3	1	05010001	Screw TH M16 x 90 Zn R/H & L/H
4	1	05014307	Self Braked Nut M16 R/H & L/H
5	1	00480020	Pushbutton R/H & L/H
6	1	05011966	Compression Spring R/H & L/H
7	1	05014081	Elastic Pin Ø12 x 50 R/H & L/H
8	1	05011973	Compression Spring R/H & L/H
9	1	05014112	Pin V6 x 70 R/H & L/H
10	1	05029516	Clamping Wedge R/H & L/H
11	2	05010165	Screw TH M14 x 25 R/H & L/H

## 8 LEAF REMOVER PARTS (CONTINUED)

### 8.9 LOWER ARM R/H - L/H REF. 0401 0943 - 0401 0944

PL 2802

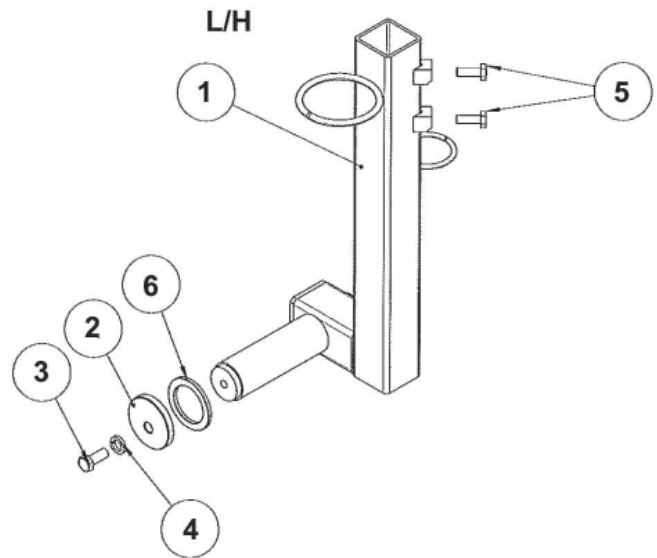
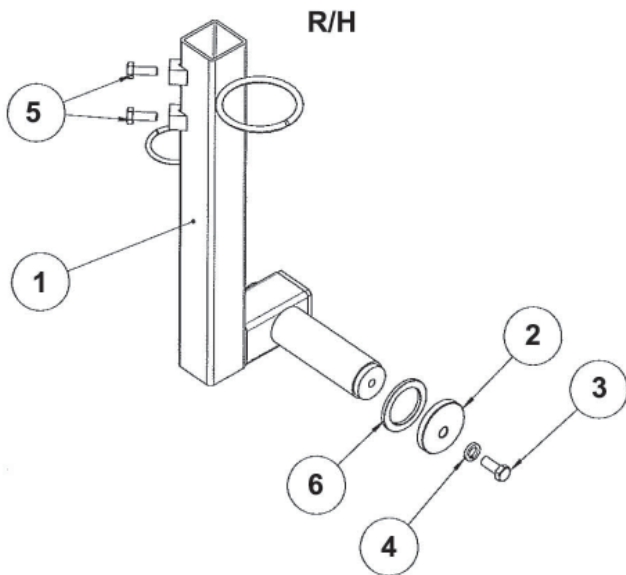

<u>REF.</u>	<u>QTY.</u>	<u>PART NO.</u>	<u>DESCRIPTION</u>
1	1	04010901	Lower Arm R/H
1	1	04010901bis	Lower Arm L/H
2	1	04010902	Eccentric Washer R/H & L/H
3	1	05010040	Screw TH M12 x 30 Zn R/H & L/H
4	1	05015312	Washer W 14 R/H & L/H
5	2	05010025	Screw TH M10 x 30 R/H & L/H
6	1	04010903	Washer R/H & L/H

## 8 LEAF REMOVER PARTS (CONTINUED)

### 8.10 LARGE LOWER FIXING REF. 0000 1476

PL 2262

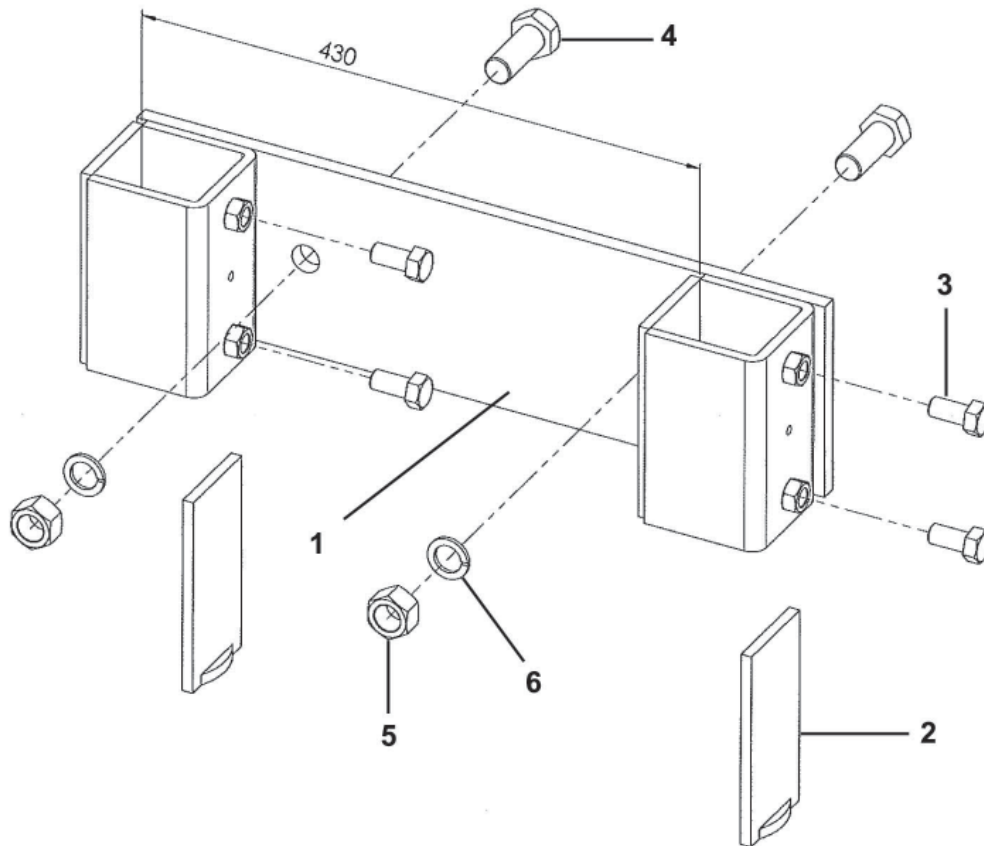

<u>REF.</u>	<u>QTY.</u>	<u>PART NO.</u>	<u>DESCRIPTION</u>
1	1	00200470	Large Fixing For a Front Mounting
2	2	05029511	Flat Blocking
3	4	05010038	Screw M14 x 30
4	2	05010043	Screw TH M20 x 50 Zn
5	2	05011200	Nut H M 20 Zn
6	2	05015315	Washer W20

## 8 LEAF REMOVER PARTS (CONTINUED)

### 8.11 ARM UNITS WITH TWIN ROTORS REF. 0401 0949 (R/H)

PL 4696

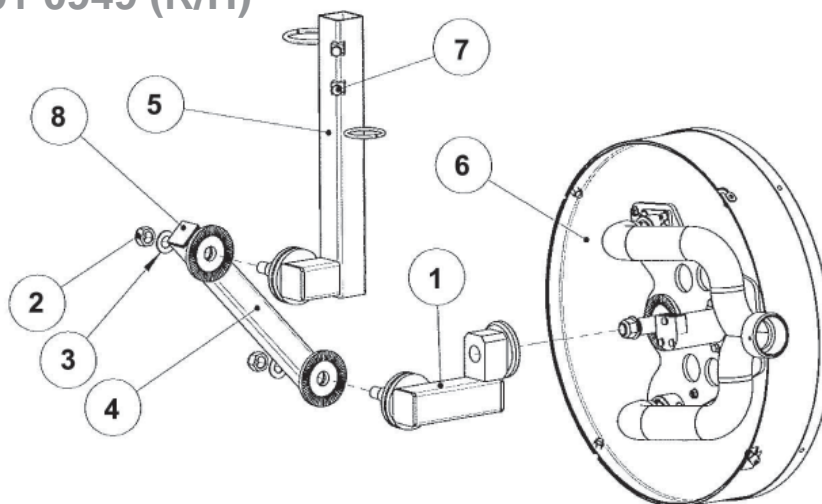

<u>REF.</u>	<u>QTY.</u>	<u>PART NO.</u>	<u>DESCRIPTION</u>
1	1	04010948	Articulation
2	2	05014301	Locknut M20 x 250
3	2	05015022	Washer M20 Zn
4	1	04010947	Arm Support
5	1	04010945	Arm R/H
6	1	04017650	Defoliating Head "Twin Rotor"
7	2	05010025	Screw M10 x 30
8	2	05017869	Cap

### REF. 0401 0950 (L/H)

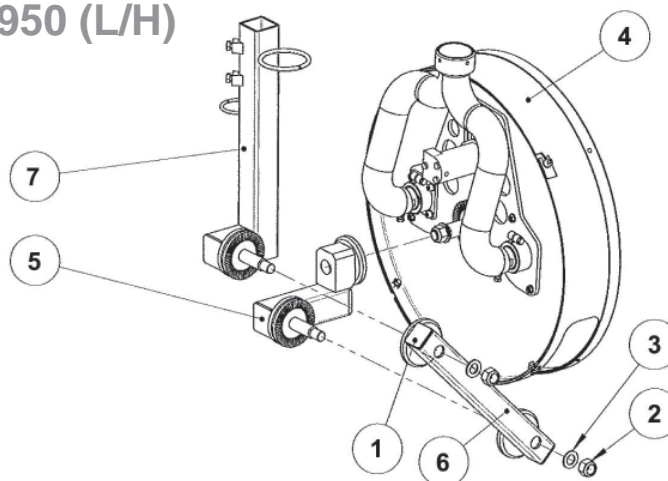

<u>REF.</u>	<u>QTY.</u>	<u>PART NO.</u>	<u>DESCRIPTION</u>
1	2	05017869	Cap
2	2	05014301	Locknut M20 x 250
3	2	05015031	Washer Z20
4	1	04017650	Defoliating Head "Twin Rotor"
5	1	04010948-bis	Articulation
6	1	04010947	Arm Support
7	1	04010945-bis	Arm L/H

# 8 LEAF REMOVER PARTS (CONTINUED)

## 8.11A DEFOLIATING HEAD TWIN ROTOR REF. 0401 7650

PL 4516

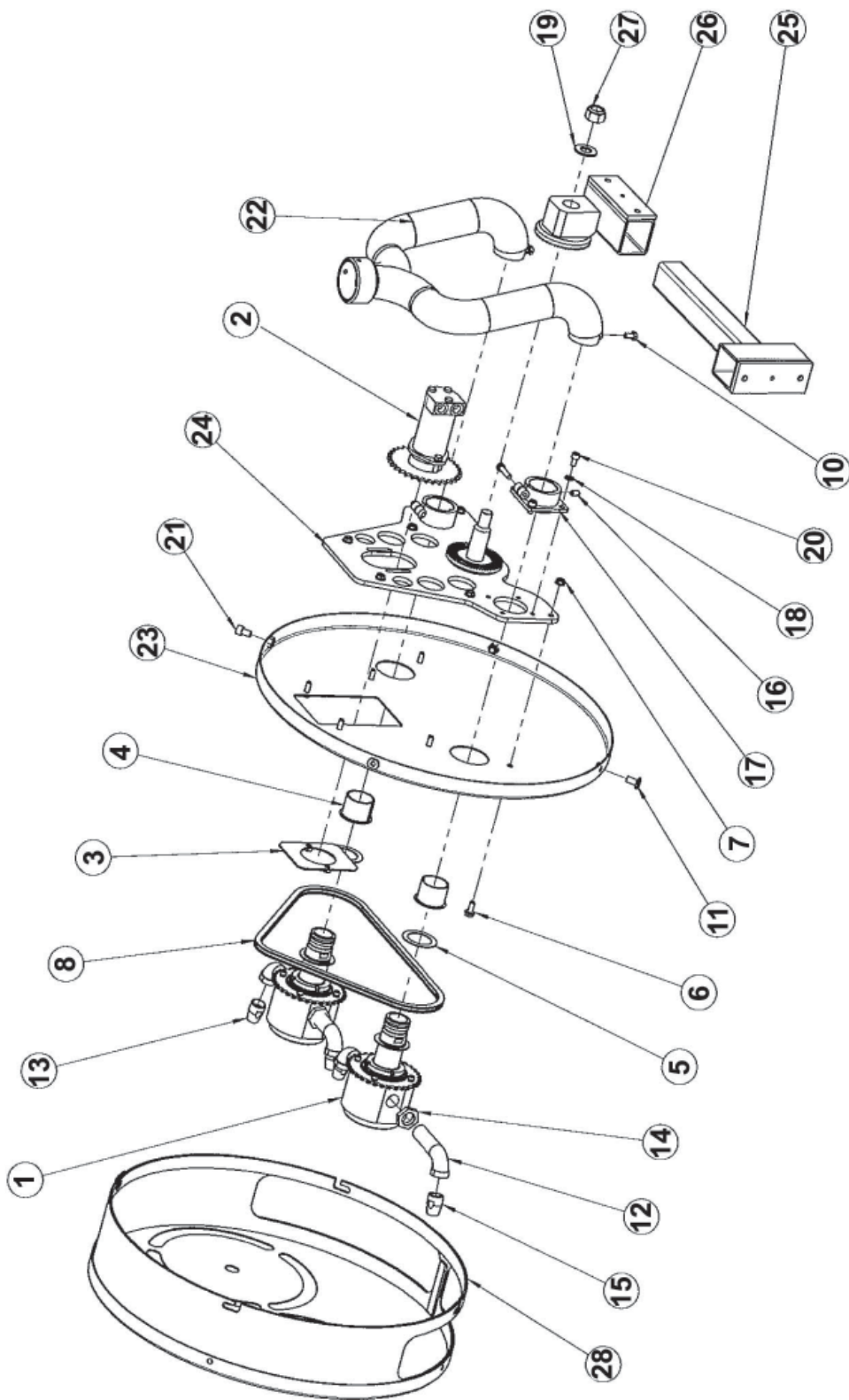

## 8 LEAF REMOVER PARTS (CONTINUED)

<u>REF.</u>	<u>QTY.</u>	<u>PART NO.</u>	<u>DESCRIPTION</u>	<u>ASSY.</u>
1	2	04017625	Air Distributor Assy 360°	PL 3882 - Pg. 48
2	1	04017643	Motor	PL 3882 - Pg. 48
3	1	04010741	Motor Fixation	
4	2	04012344	Ring	
5	2	04017617	Pushing Washer	
6	6	05011866	Screw Tensilok M8 x 20	
7	6	05011216	Nut M8 Tensilok	
8	1	04017609	Chain	
9	2	05010146	Screw TH M8 x 35	
10	2	05010149	Screw TH M8 x 16	
11	3	04012713	Screw	
12	4	04017605	Body Nozzle Long	
13	2	04012339	Nozzle Ø12	
14	4	05011889	Nut 3/4 Gaz	
15	2	04017614	Nozzle Ø12	
16	2	05010801	Screw HC M8 x 16	
17	1	04017628	Split Ring	
18	4	05015026	Washer M8	
19	1	05015022	Washer M20 Zn	
20	4	05010913	Screw CHC M8 x 15	
21	1	05010980	Screw CHC M10 x 16	
22	1	04017629	Air Distributor	
23	1	04017633	Back	
24	1	04017636	Double Platine Kit	
25	1	04017640	Square Support	
26	1	04017641	Articulation	
27	1	05014301	Locknut M20 x 250	
28	1	04017634	Cover	

# 9 REAR BOOSTER PARTS

## 9.1 REAR BOOSTER ON 3-PT. FRAME REF. 0403 0400

PL 5020

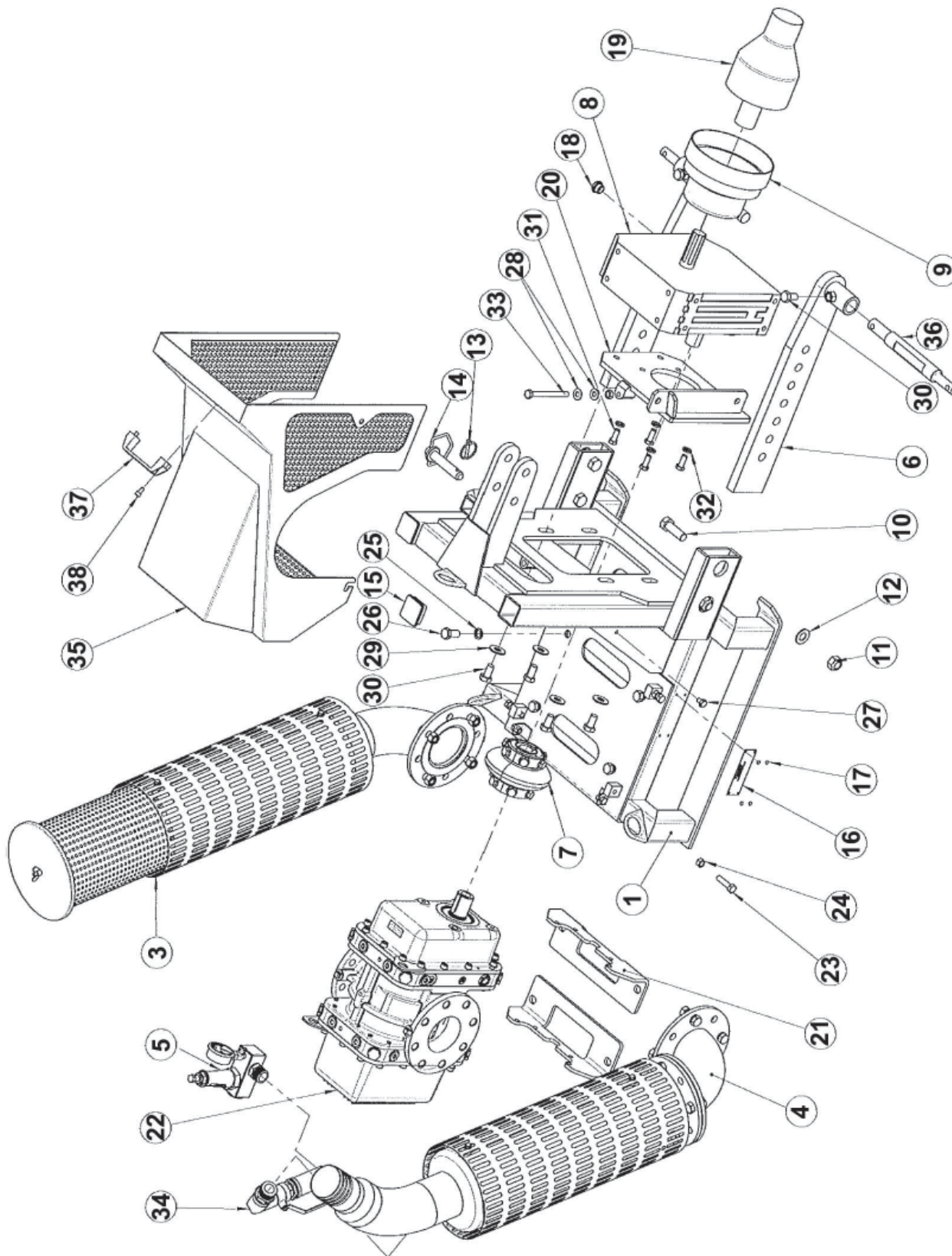



## 9 REAR BOOSTER PARTS (CONTINUED)

<u>REF.</u>	<u>QTY.</u>	<u>PART NO.</u>	<u>DESCRIPTION</u>	<u>ASSY.</u>
1	1	04030401	Rear Welded Frame	
2	1	04012529	Support	
3	1	04225018	Air Intake Pipe Kit	PL 5011 - Pg. 44
4	1	04225016	Air Exhaust Pipe Silencer	PL 5129 - Pg. 45
5	1	04225017	Pressure Checking Unit	PL 5008 - Pg. 46
6	1	04012529-bis	Support	
7	1	05045580	Coupling Assembly Boss Ø35 - Ø42	PL 5005 - Pg. 50
8	1	05021347	Gearbox 7/1	
9	1	05028254	Protection Bowl	
10	4	05010106	Screw TH M20 x 60 Zn	
11	4	05014301	Self Braking Nut M20	
12	4	05015022	Washer M20 Zn	
13	1	05014050	Bolt Pin Ø6 Zn	
14	1	05016221	Broach	
15	2	05017886	Cap For Tube 60 x 4	
16	1	05016066	Identify Plate	
17	4	05011650	Rivet POP Ø4 x 8	
18	1	3192	Oil Level Indicator	
19	1	05028256	Cardans Shaft	
20	1	04225003	Support For Gearbox	
21	2	04225004	Support For Booster NX3	
22	1	05045059	Booster NX3 (R/H Rotation)	
23	4	05010042	Screw TH M12 x 50	
24	5	05011203	Nut M 12 Hu	
25	4	05015314	Washer W16	
26	4	05010002	Screw TH M16 x 35	
27	4	05010022	Screw TH M10 x 15	
28	2	05015009	Washer M12	
29	4	05015008	Washer Lu 16	
30	6	05010120	Screw TH M16 x 30	
31	4	05010040	Screw TH M12 x 30	
32	4	05015316	Washer W12	
33	1	05010206	Screw TH M12 x 130 Zn Complete Threading 8.8	
34	1	04225015	Relief Valve Assembly 1 1/4"	PL 5009 - Pg. 47
35	1	04225022	Booster Protection	
36	2	04012530	Coupling Broach	
37	1	05017944	Handle	
38	2	05010913	Screw CHC M8 x 15	

## 9 REAR BOOSTER PARTS (CONTINUED)

### 9.2 AIR INTAKE PIPE KIT REF 0422 5018

PL 5011

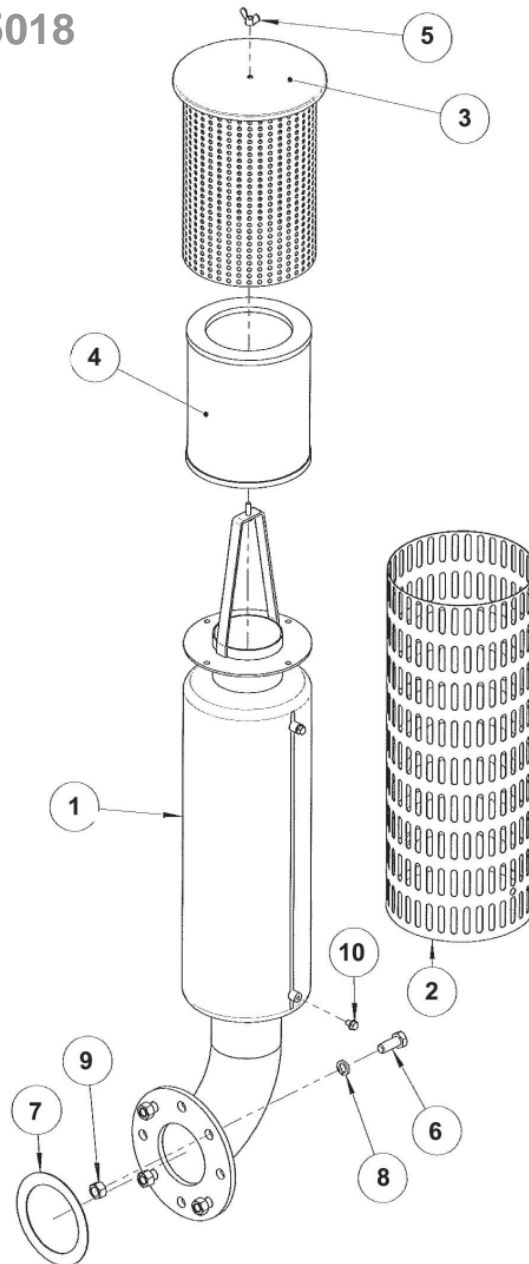

<u>REF.</u>	<u>QTY.</u>	<u>PART NO.</u>	<u>DESCRIPTION</u>
1	1	04225013	Welded Intake Pipe
2	1	04011647	Silencer Protection
3	1	04010847	Protection For Filter
4	1	05045011	Cartridge
5	1	05011227	Nut M8
6	4	05010118	Screw TH M16 x 40 Zn
7	1	05045014	Flange Joint Ø120/160
8	4	05015314	Washer W16
9	4	05011201	Nut M16 Hu
10	4	05011861	Screw Tensilock M8 x 12 Zn

## 9 REAR BOOSTER PARTS (CONTINUED)

### 9.3 AIR EXHAUST PIPE KIT REF 0422 5016

PL 5129

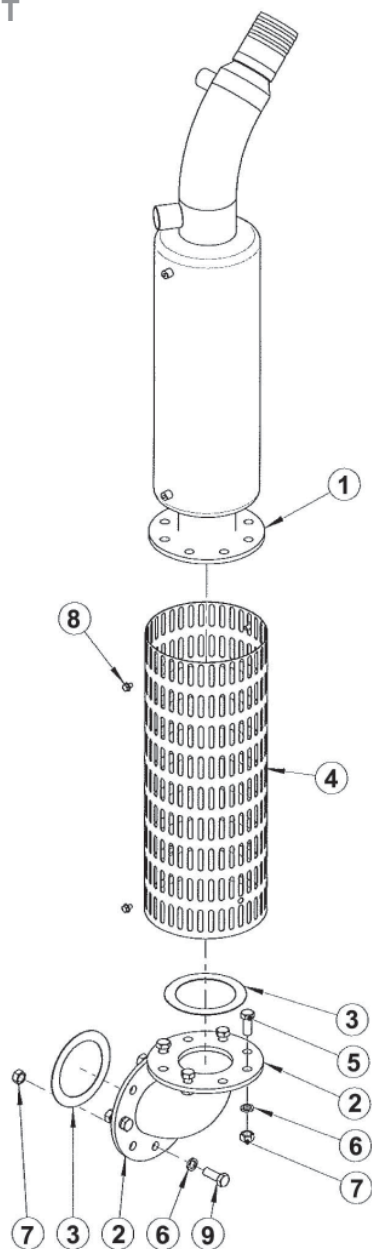

<u>REF.</u>	<u>QTY.</u>	<u>PART NO.</u>	<u>DESCRIPTION</u>
1	1	04225014	Exhaust Pipe
2	1	04225011	Elbow
3	2	05045014	Flange Joint Ø120/160
4	1	04011647	Silencer Protection
5	4	05010118	Screw TH M16 x 40 Zn
6	8	05015314	Washer W16
7	8	05011201	Nut H M16 Zn
8	4	05011861	Screw Tensilock M8 x 12 Zn
9	4	05010170	Screw TH M16 x 45 Zn

## 9 REAR BOOSTER PARTS (CONTINUED)

### 9.4 PRESSURE CHECKING UNIT REF 0422 5017

PL 5008

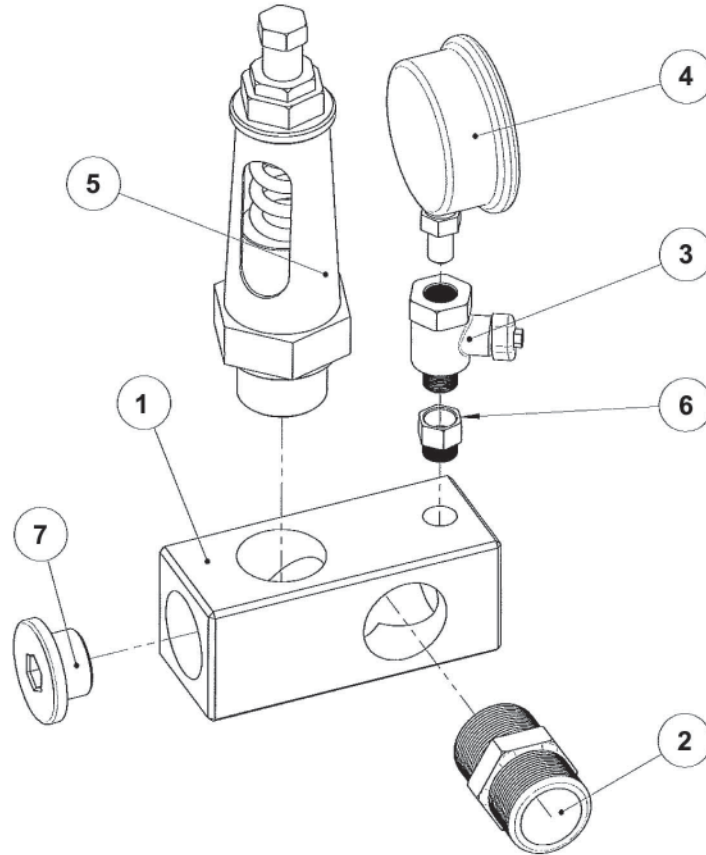

<u>REF.</u>	<u>QTY.</u>	<u>PART NO.</u>	<u>DESCRIPTION</u>
1	1	04011671	Pressure Block
2	1	05008707	Double Connection 1"
3	1	05045018	Tap 1/4"
4	1	05045063	Air Pressure Indicator
5	1	05045015	Safety Air Valve
6	1	4265	Male-Female Connection 1/4"
7	1	05007116	Plug 1" Gaz

## 9 REAR BOOSTER PARTS (CONTINUED)

### 9.5 RELIEF VALVE ASSEMBLY 1 1/4" REF 0422 5015

PL 5009

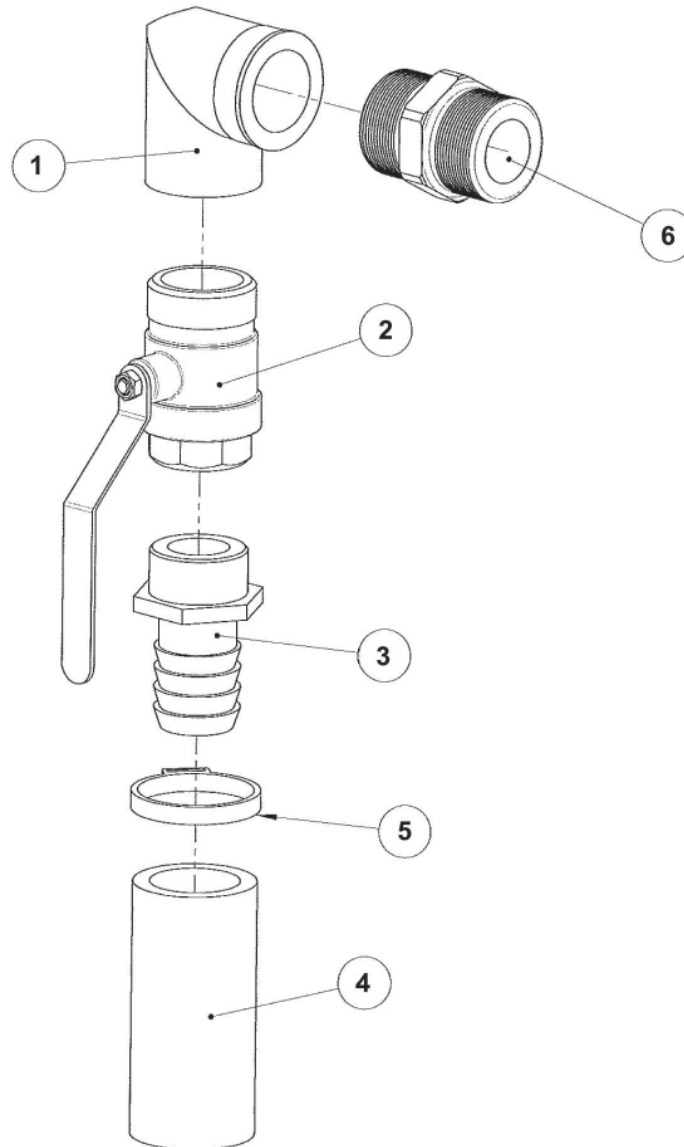

<u>REF.</u>	<u>QTY.</u>	<u>PART NO.</u>	<u>DESCRIPTION</u>
1	1	30030048	Male/Female Elbow 1 1/4"
2	1	30030052	Relief Valve 1 1/4"
3	1	30030050	Hose Connection 1 1/4"
4	1	05022358	Hose Ø 48 x Ø35 L=1000
5	1	1758	Collar With Screw
6	1	30030049	Double Connection 1 1/4"

## 9 REAR BOOSTER PARTS (CONTINUED)

### 9.6 MOTOR KIT REF 0401 0715

PL 3882

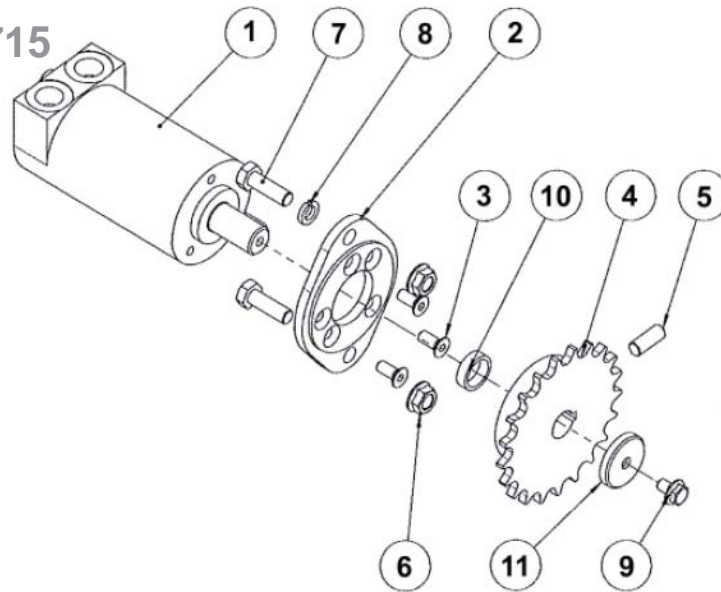

<u>REF.</u>	<u>QTY.</u>	<u>PART NO.</u>	<u>DESCRIPTION</u>
1	1	05021054	Motor OMM 20
2	1	04010765	Bridle
3	3	05010512	Screw FHC M6 x 15
4	1	00601549	Pinion 12.7 x 4.5 - 21 Teeth
5	1	05010805	Screw HC M10 x 20
6	2	05011216	Nut Tensilok M8 Zn
7	2	05010016	Screw TH 8 x 25 Zn
8	2	05015317	Washer W8 Zn
9	1	05011869	Screw Tensilok M6 x 10 Zn
10	1	04012715	Ring Spacer
11	1	04010799	Washer

### 9.7 COMPLETE AIR DISTRIBUTOR KIT REF 0401 7625

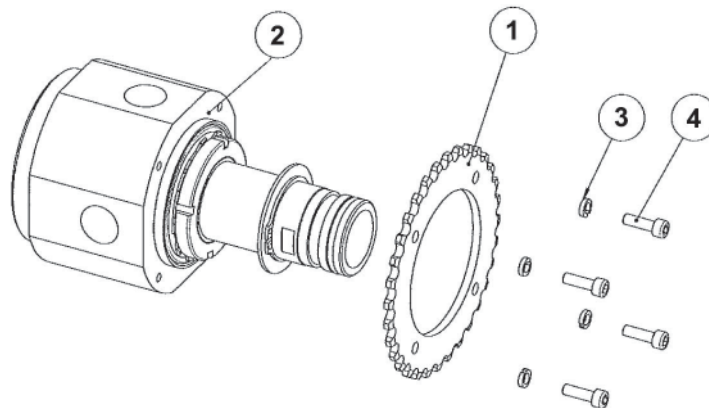

<u>REF.</u>	<u>QTY.</u>	<u>PART NO.</u>	<u>DESCRIPTION</u>	<u>ASSY.</u>
1	1	05027055	32 Teeth Disc, 12.7 Pitch	
2	1	04017626	Air Distributor 360°	PL 3883 - Pg. 49
3	4	05015318	Washer W6 Zn	
4	4	05010937	Screw CHC M6 x 20	

## 9 REAR BOOSTER PARTS (CONTINUED)

### 9.8 AIR DISTRIBUTOR KIT REF 0401 7626

PL 3883

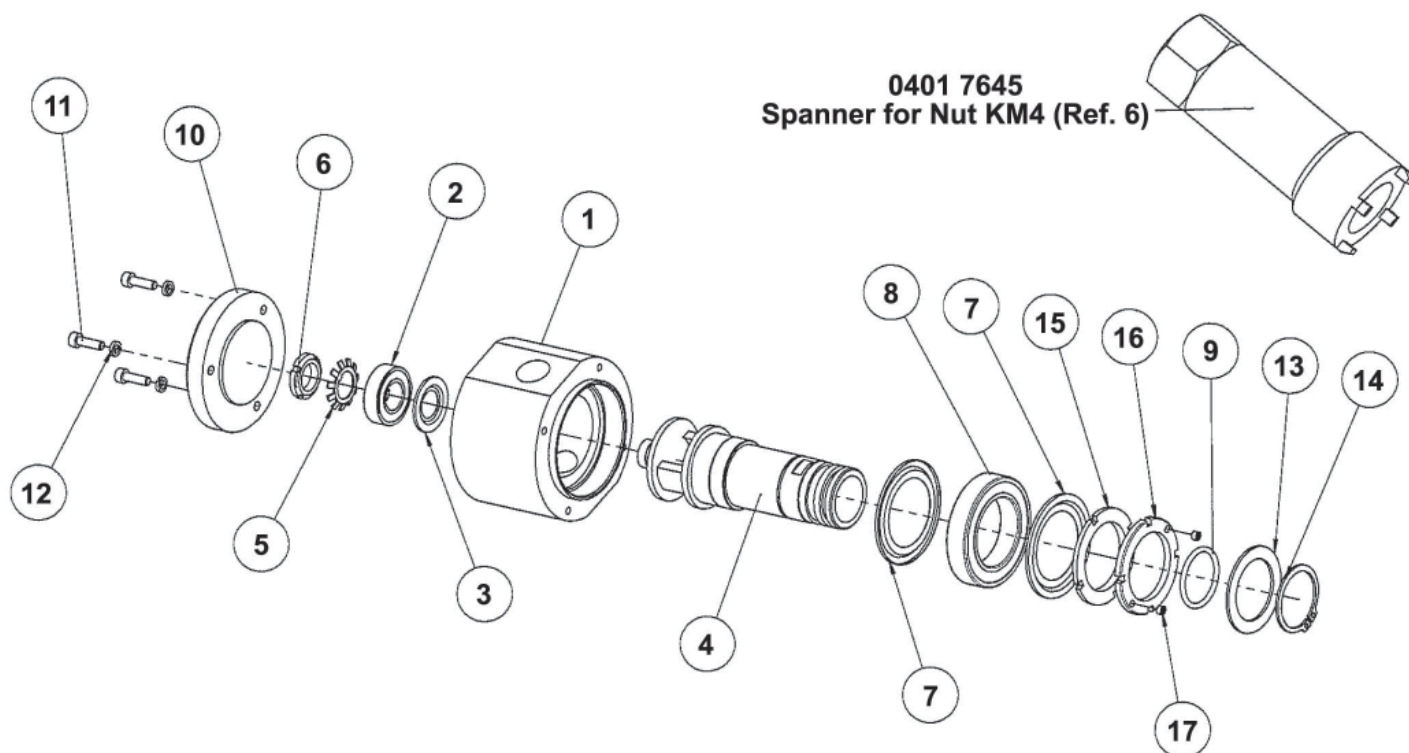

<u>REF.</u>	<u>QTY.</u>	<u>PART NO.</u>	<u>DESCRIPTION</u>
1	1	04017627	Air Distributor Body
2	1	05003033	Bearing
3	1	05000065	Ring
4	1	04017624	Hollow Shaft
5	1	05005259	Washer MB4
6	1	05005214	Nut KM4
7	2	05000066	Ring
8	1	05003036	Bearing 6010 2RS1
9	1	05001322	O-Ring R27
10	1	04012826	Plug
11	3	05010900	Screw CHC M6 x 20
12	3	05015318	Washer W6 Zn
13	1	04012827	Pushing Washer
14	1	05013008	Ring Ø45
15	1	04017669	Nut KM 10
16	1	04017668	Nut KM 10
17	2	05010991	Screw STHC M8 x 35

## 9 REAR BOOSTER PARTS (CONTINUED)

### 9.9 COUPLING ASSEMBLY WITH BOSS Ø35 - Ø42 REF 0504 5580

PL 5005

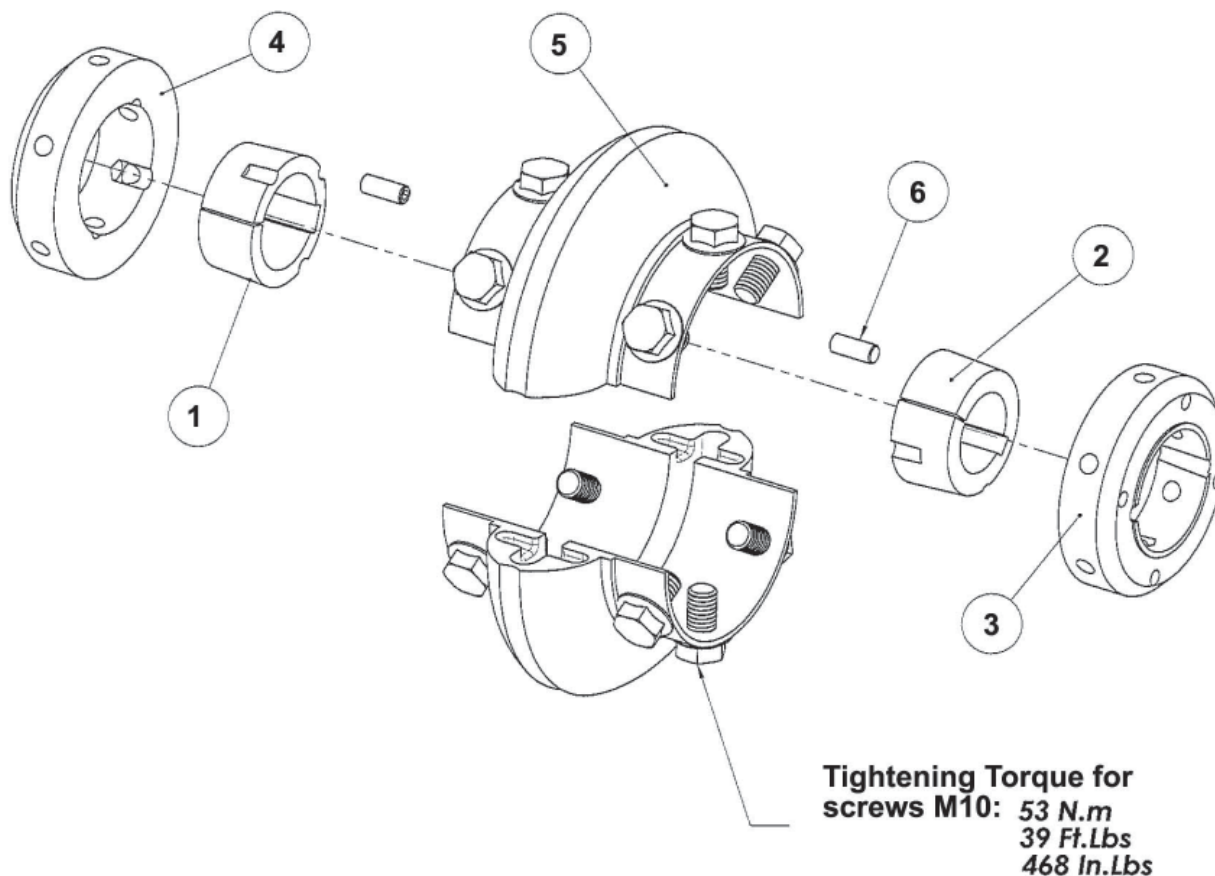

<u>REF.</u>	<u>QTY.</u>	<u>PART NO.</u>	<u>DESCRIPTION</u>
1	1	05045579	Boss 1610/42
2	1	05045518	Boss 1610/35
3	1	04012434	Fixation for Propeller
4	1	05045527	Plate
5	1	05045528	Coupling V170
6	2	05010805	Screw HC M10 x 20



## 9 REAR BOOSTER PARTS (CONTINUED)

### 9.10 COMPLETE ANGLE BRAKE ASSEMBLY REF 0500 9086

PL 4365

#### FEEDING FLOW ADJUSTMENT ON CYLINDER

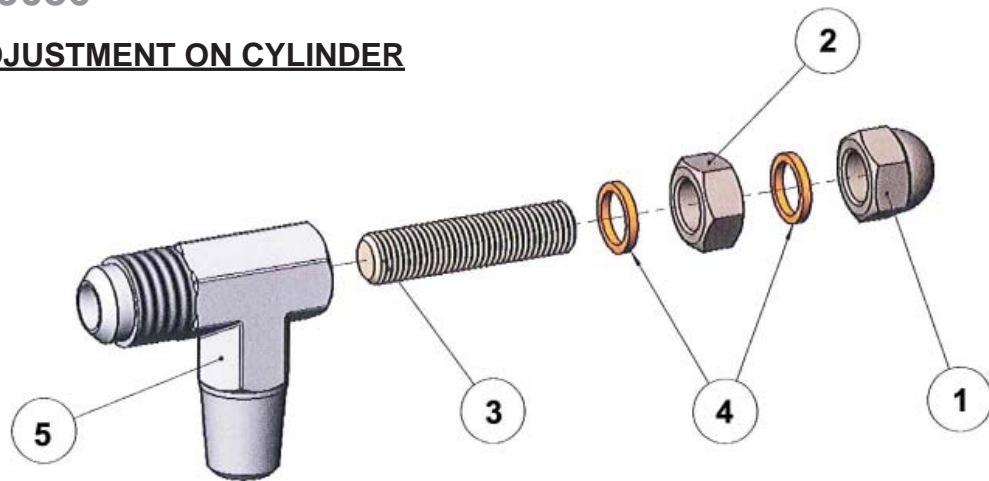

<u>REF.</u>	<u>QTY.</u>	<u>PART NO.</u>	<u>DESCRIPTION</u>
1	1	05011204	Nut M8
2	1	05011206	Nut M8 Hu
3	1	05010830	Screw STHC M8 x 35
4	2	05002009	Joint Ø8.2 x 11.2 x 1
5	1	05009081	Angle 9/16" JIC

#### PLAY ADJUSTMENT ON SLIDING TUBE

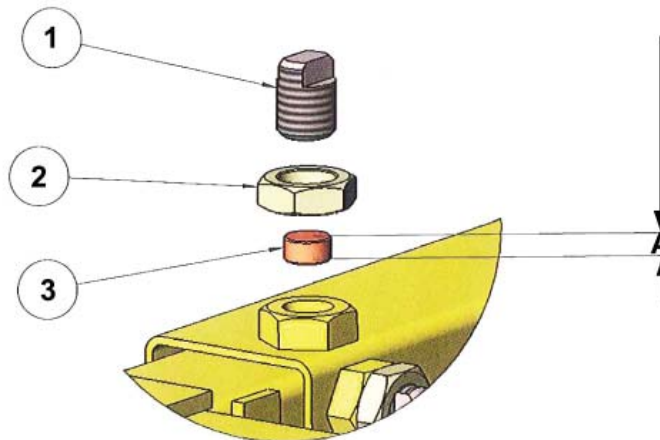

<u>REF.</u>	<u>QTY.</u>	<u>PART NO.</u>	<u>DESCRIPTION</u>
1	1	0501 0814	Screw M20
2	1	0501 1208	Nut HM20 Zn
3	1	0501 4315	Plastic Plug - A = 4mm
3	1	0501 4309	Plastic Plug - A = 8mm
3	1	0501 4316	Plastic Plug - A = 12mm
3	1	0501 4314	Plastic Plug - A = 16mm

# 10 HYDRAULIC PARTS

## 10.1 CYLINDER DE 35 - 25

PL 1604

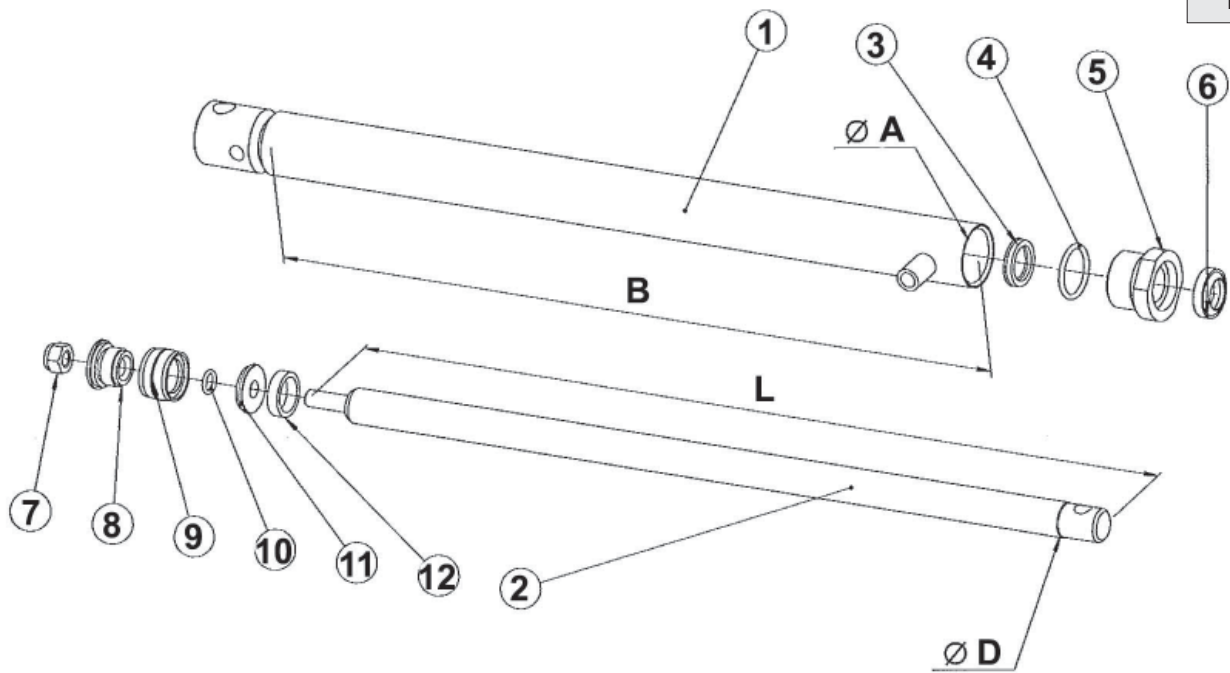

<u>REF.</u>	<u>QTY.</u>	<u>PART NO.</u>	<u>DESCRIPTION</u>
1	1	05019189	Body (See Table Below)
2	1	05019463	Rod (See Table Below)
3	1	05001307	O-Ring
4	1	05000042	Rod Joint Ø25
5	1	05019117	Threaded Base
6	1	05001004	Top Rod Joint Ø25
7	1	05014300	Brake Nut M12
8	1	05019670	Half Piston
9	1	05000041	Piston Joint
10	1	05001301	O-Ring R 10
11	1	05019671	Flask
12	1	05005319	Spacing Ring

Dimensions in mm							
Cylinder	Rod	Body	Ø A	B	L	Ø D	Stroke
0502 0020	0502 0021	0502 9456	45	474	545	25	400
0501 9461	0501 9463	0501 9189	45	574	645	25	500
0501 9247	0501 9248	0501 9249	45	874	945	25	800
0501 9556	0501 9557	0501 6169	45	774	845	25	700
0501 9962	0501 9963	0501 9964	45	1274	1345	25	1200
0501 9951	0501 9953	0501 9426	45	1074	1145	25	1000

- Set of Seals: 0501 9679

# 10 HYDRAULIC PARTS (CONTINUED)

## 10.2 DOUBLE EFFECT CYLINDER Ø35 - 18

PL 1601

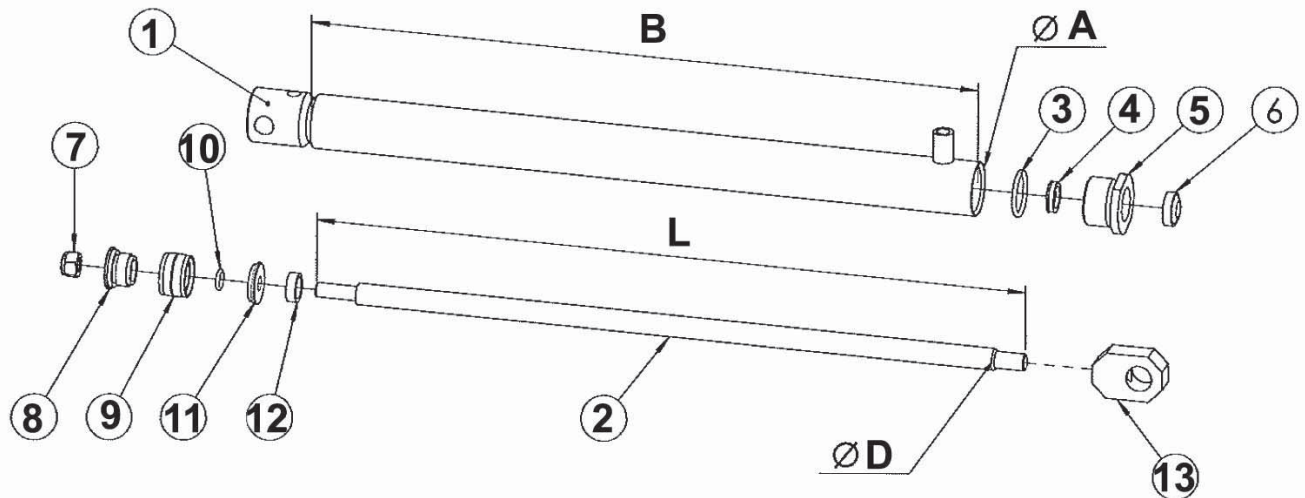

1	1	Corps-Body D35	Body (See Table Below)
2	1	Tige-Rod D18	Rod (See Table Below)
3	1	05001307	O-Ring
4	1	05000043	Joint
5	1	05019005	Threaded Base
6	1	05001002	Joint
7	1	05014300	Brake Nut M12
8	1	05019670	Half Piston
9	1	05000041	Piston Joint
10	1	05001301	O-Ring R 10
11	1	05019671	Flask
12	1	05019004	Flange
13	1	05019144	Fork

Dimensions in mm							
Cylinder	Rod	Body	Ø A	B	L	Ø D	Stroke
0501 9145	0501 9014	0501 9096	45	164	200	18	90
0501 9167	0501 9168	0501 9169	45	774	810	18	700
0501 9187	0501 9188	0501 9189	45	574	610	18	500
0501 9211	0501 9212	0501 9213	45	199	235	18	125
0501 9218	0501 9203	0501 9204	45	374	410	18	300
0501 9290	0501 9291	0501 9292	45	274	310	18	200
0501 9300	0501 9301	0501 9302	45	324	360	18	250
0501 9354	0501 9355	0501 9356	45	424	460	18	350
0501 9455	0501 9457	0501 9456	45	474	510	18	400
0501 9482	0501 9483	0501 9484	45	674	710	18	600
0501 9764	0501 9362	0501 9363	45	224	260	18	150
0501 9798	0501 9352	0501 9353	45	174	210	18	100

- Set of Seals: 0501 9678

# 10 HYDRAULIC PARTS (CONTINUED)

## 10.3 CYLINDER DOUBLE EFFECT 35 - 18

PL 1620

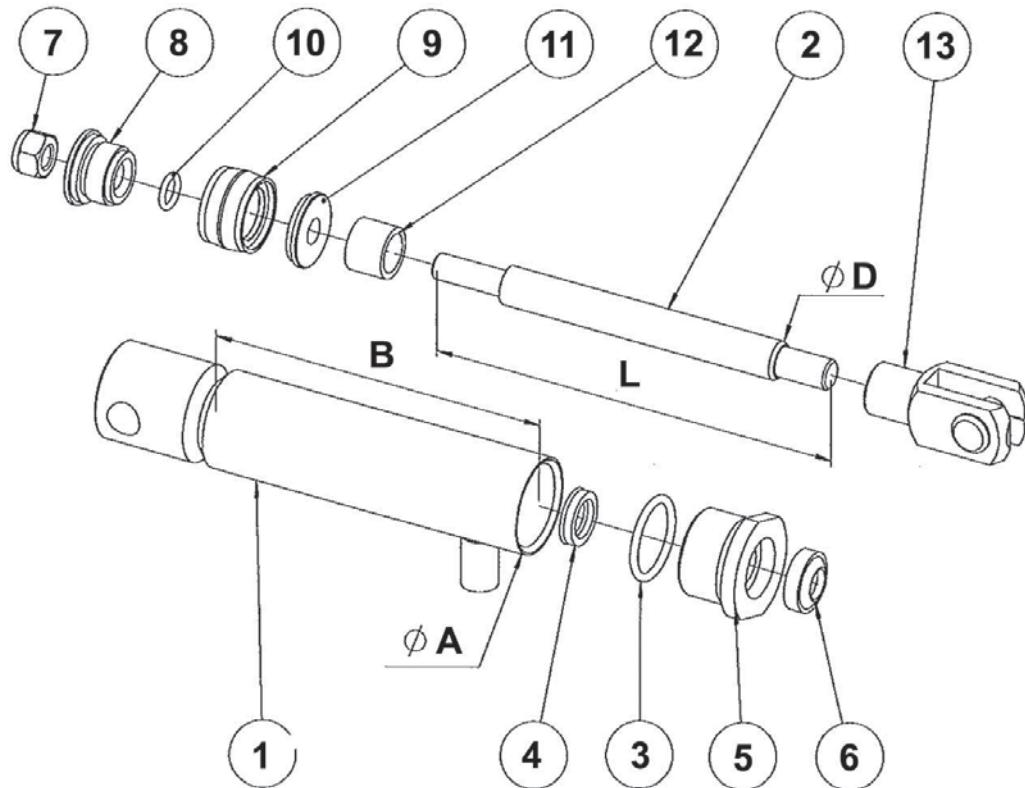

<u>REF.</u>	<u>QTY.</u>	<u>PART NO.</u>	<u>DESCRIPTION</u>
1	1	Corps-Body D35	Body (See Table Below)
2	1	Tige-Rod D18	Rod (See Table Below)
3	1	05001307	O-Ring
4	1	05000043	Joint
5	1	05019005	Threaded Base
6	1	05001002	Joint
7	1	05014300	Brake Nut M12
8	1	05019670	Half Piston
9	1	05000041	Piston Joint
10	1	05001301	O-Ring R 10
11	1	05019671	Flask
12	1	05005372	Flange
13	1	05029100	Fork

Dimensions in mm							
Cylinder	Rod	Body	Ø A	B	L	Ø D	Stroke
0501 9601	0501 9014	0501 9033	45	164	200	18	80

- Set of Seals: 0501 9678

## 10 HYDRAULIC PARTS (CONTINUED)

### 10.4 COMPLETE NON RETURN SECURITY VALVE JIC REF. 0000 1322J

PL 2986

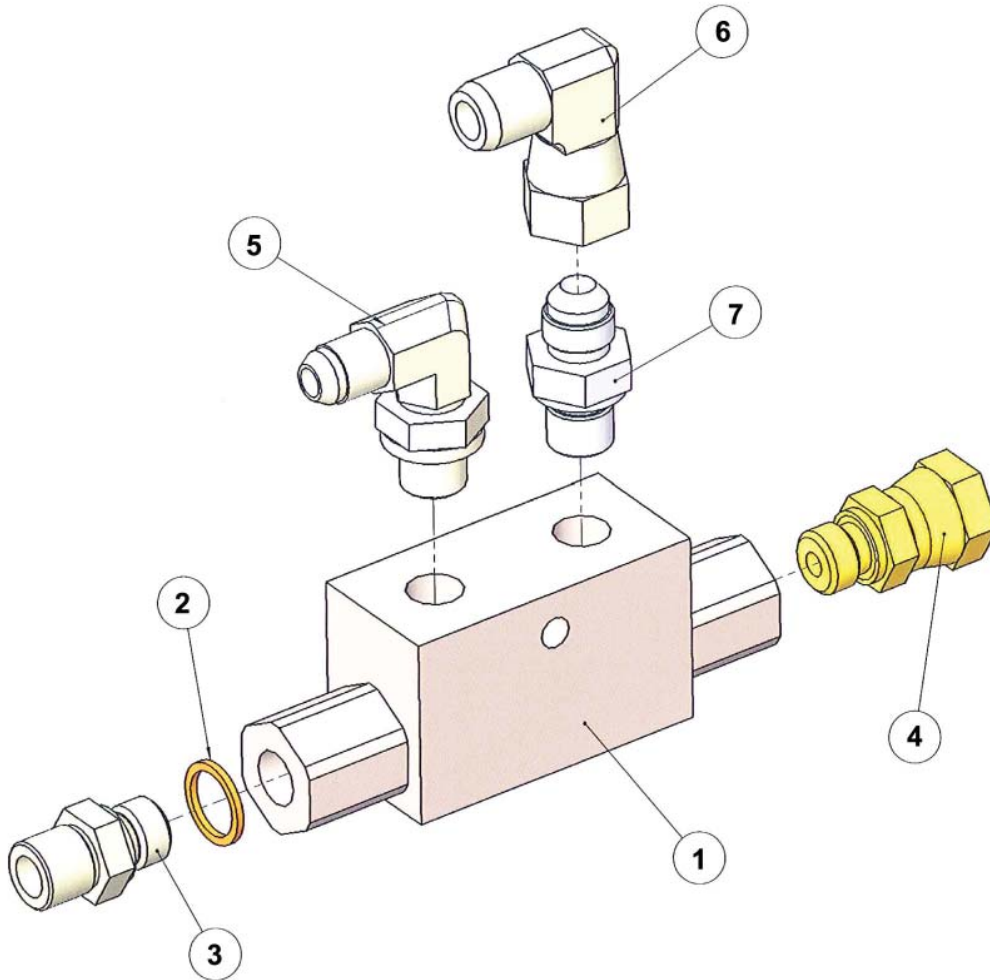

<u>REF.</u>	<u>QTY.</u>	<u>PART NO.</u>	<u>DESCRIPTION</u>
1	1	05023307	Double Valve
2	1	05002006	Joint
3	1	05007767	Junction
4	1	05007814	Adapter FJ 9/16" - 1/4" Gas Cyl.
5	1	05006577	Elbow MJ 9/16 - MG 1/4 90°
6	1	05006420	Elbow MJ 9/16 - FJ 9/16 90°
7	1	05007816	Junction MJ 9/16 MG 8/13

# 11 OPTIONS

PL 2708

## 11.1 PREFILTRATION KIT REF. 0000 1638A

<u>REF.</u>	<u>QTY.</u>	<u>PART NO.</u>	<u>DESCRIPTION</u>
1	1	04012438	Cover
2	1	04012439	Filter Box
3	1	05045032	Prefiltration Kit
4	1	04012453	Cap

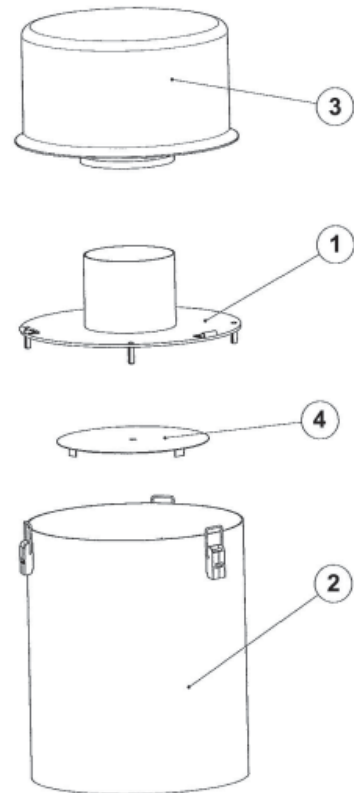

## 11.2 VENTILATION KIT FOR "RAPTOR" REF. 0000 1637

PL 2707

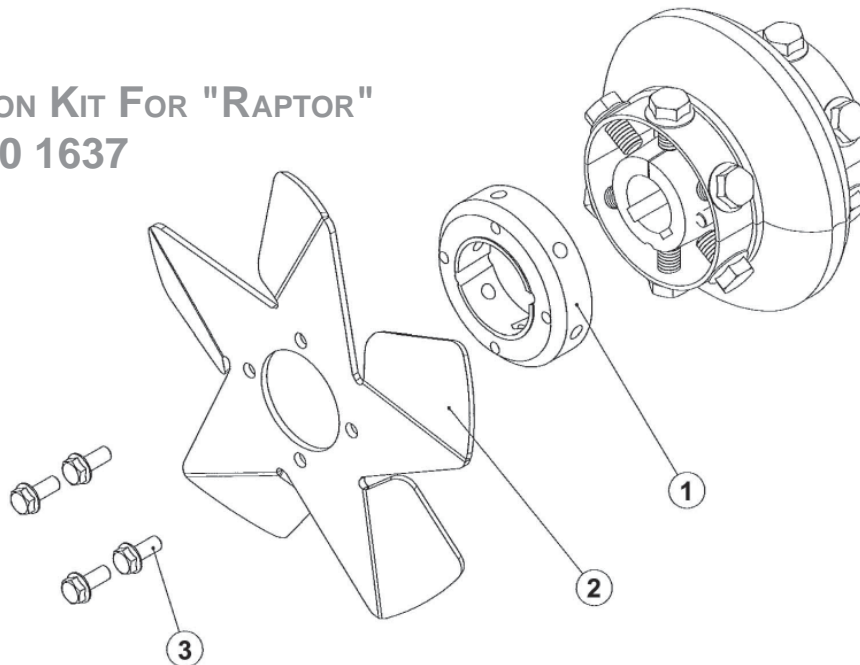

<u>REF.</u>	<u>QTY.</u>	<u>PART NO.</u>	<u>DESCRIPTION</u>
1	1	04012434	Fixation For Propeller
2	1	04012430	Five Bladed Propeller
3	4	05011866	Screw Tensilok M8 x 20