



2011 Product Catalog

Providing Quality Implements at Affordable Prices

This catalog presents a wide selection of equipment. Farm, ranch, landscape, municipal, and construction equipment users will find **217** different implements in **775** different widths or capacities to fit their exact requirements.

Gearmore has been providing quality implements, through servicing tractor dealers, for over 45 years. It is Gearmore's continuing goal to develop and provide the finest and most reliable implements at affordable prices.

Please use this catalog when considering your equipment requirements, then visit your local tractor dealer for more detailed product information and pricing.



LARGEST INVENTORY OF IMPLEMENTS ON THE WEST COAST
"OUR FACILITY HAS OVER 2 ACRES UNDER ROOF, OVER 93,000 SQ. FT., AND EASY ACCESS FOR LOADING TRUCKS"

PRODUCT INDEX	PAGE NO.
Aerators, Slicing1
Aerators, Coring2
Backhoes, Thumbs3
Blades4, 5
Breakers, Compactors6
Brush Processor7
Chippers8
Cultivators, Arena9
Cultivators, In-Row10
Diggers & Augers11, 12
Discs13 - 19
Dusters20, 21
Dusters, Row Crop22
Forks, Bale Spear23 - 25
Harrows, Chain26
Harrows, Rotary27
Implements, Compact Tractor28
Implements, Construction29
• Skid Hoe, 4-in-1 Bucket, Sifting Bucket, 3-Point Trencher29
Implements, Miscellaneous30, 31
• Plows, Spring Shank Cultivators, Ripper Bars, Mixer30
• Arena-Vator Jr., Spreader, Compact Wheel Disc, Roller Compactors31
Loaders, Implements32
Loaders, Grapple Kit33
Loaders, Hydraulic Kits33
Log Splitters34
Mowers/Shredders, Flail35 - 43

PRODUCT INDEX	PAGE NO.
Mowers, Rotary44 - 47
Mulchers, Row48
Planters49
Quick Hitches11
Rakes, Basket50
Rakes, Landscape51
Ridgers52
Rippers53 - 57
Scrapers, 3-Point58 - 61
Scrapers, Corral62
Scrapers, Drag62, 63
Scrapers, Grading64
Scrapers, Laser65, 66
Skid Steer Attachments67, 68
Skid Steer Compact Attachments69
Soil Conditioners70
Sprayers, Boom71 - 75
Sprayers, Air Blast76, 77
Sprayers, Venturi, 3-Point78
Sprayers, Venturi, Trailer79 - 81
Sprayers, Distribution Heads82
Sprayer, Air Boom83
Spreaders, Spinner84 - 86
Spreaders, Pendulum87
Spreaders, Manure88
Sweepers89
Tillers90 - 92
Top Dressers93
Top & Tilt Kits94
Trailers, Dump95

Specifications of products shown are subject to change without notice. Due to exclusive arrangements, not all products may be available from all dealers.



12 FOOT PULL TYPE MODEL WITH OPTIONAL WEIGHT BOXES SHOWN

Our **Slicing Aerators** were designed for growers committed to producing healthier crops. Due to the many passes with heavy equipment, fields become very compacted. Thus, it becomes necessary to fracture the soil to increase air and water movement. Our unique twisted tines open the soil up to 8 inches deep; this then produces a stronger root zone that achieves higher yields. The quick change tine rotors are adjustable at 0°, 5°, or 10° to produce the aeration opening sizes for your particular needs. Our 3-point hitch aerators are available in widths of 8, 10, 12, and 15 feet. If a pull type aerator is better for your requirements, a bolt-on carrier can be added or purchased when you order our aerator. These slicing aerators also do an excellent job on alfalfa, orchard cover crop, pastures, turf growers, and many other crops.

FEATURES:

- Available in widths of 8', 10', 12', and 15'
- Replaceable bolt-on 9" long twisted tines
- Heat treated, high abrasion resistant, steel alloy twisted tines
- Tines are on 7 1/2" spacing
- 3-Point, Cat. 2 clevis hitch
- 3 1/2" Diameter by 7" long spacer spools
- 4 Tine pattern on each rotor plate
- Quick change gang beams at 0°, 5°, or 10° angle

- 1 15/16" Diameter 1018 steel cold rolled main shaft
- Full length weight box platform & highway lighting kit

OPTIONS:

Bolt-on conversion to make 3-point a pull type unit which includes 7:60 x 15 - 8 ply floatation tires - 3,800 lbs. capacity each tire, wheel/spindle, with 6 bolt lugs, cylinder, and hoses.

SPECIFICATIONS:

MODEL NO.	OVERALL WIDTH	WORKING WIDTH	H.P. REQUIRED	NO. OF TINES	WT.
PB-800-PBR	8 Foot	7' - 3"	40 to 80	48	1925#
PB-1000-PBR	10 Foot	8' - 6"	60 to 100	56	2180#
PB-1200-PBR	12 Foot	11'	75 to 100	72	2485#
PB-1500-PBR	15 Foot	13' - 6"	90 to 150	88	2790#



60" AERATOR SHOWN WITH OPTIONAL PULL HITCH, PRESSURE ROLLER, & WEIGHT TANK

Our **Slicing Aerators** are available in 3 versions: 3-point hitch and pull type with hydraulic or electro hydraulic controls. Also available on all models is a heavy duty 8 1/2" diameter steel smoothing rear roller with poly brush scraper and 50 weight tank. The heat treated, high abrasion resistant, steel alloy shattering tines slice through tough soils up to 6 inches deep.

- Relieves soil compaction
- Improve water percolation
- Improves plant-root development
- Improves surface-water and nutrient infiltration

The turf aerators come with 3/8" thick "sports" tines on 5" centers. Farm aerators - 1/2" "Ag" tines on 7" centers.

OPTIONS:

- 50 Gallon poly tank with filler cap and drain plug for added down pressure weight of 425 lbs.
- Pull type kit - includes adj. tongue, jack stands, gauge wheels w/18 x 8.50 - 8 ply turf tires. Height adj. - hydraulic or electro hydraulic lift
- 8 1/2" Dia. 120# steel smoothing rear roller w/poly brush scraper

- Cat. I & II 3-point hitch
- Working widths of 48", 60", and 72"
- Replaceable bolt-on 6 1/2" long tines
- Tine plate spacing - 5" or 7" centers, 4 tines per rotor plate
- Heat treated, high abrasion resistant, steel alloy tines
- 4 Parking stands on 3-pt. hitch models - built-in box for added wt.

SPECIFICATIONS:

MODEL NUMBER	DESCRIPTION	OVERALL WIDTH	WORKING WIDTH	OVERALL HEIGHT	OVERALL LENGTH	WEIGHT
SP48	3-Point Aerator	60"	48"	47"	45"	730#
SP60	3-Point Aerator	72"	60"	47"	45"	790#
SP72	3-Point Aerator	84"	72"	47"	45"	850#

Our **Aerators** were especially designed for compact tractors. The spoon tine wheel assemblies turn independently on the axle, which reduce lateral torque when making gentle turns, minimizing turf damage. Parking stands keep the frame off the ground for storage and allows for easy tractor hook-up. These units reduce compaction and thatch, thereby improving water and air movement into the soil. The aerators stimulate root growth and improve turf grass health. Excellent for sports turf and areas with heavy traffic.



FEATURES:

- Cat. I, A.S.A.E. quick hitch compatible
- Coring widths of 42", 54" & 66"
- Frame designed to accept standard 8" x 8" x 16" cement blocks for added down pressure
- Coring pattern - 6" x 9"
- Weight box accepts up to 400 lbs. for down pressure
- Hardened 1/2" coring, side eject spoon tines
- Self storing parking stands
- Powder coated charcoal grey paint

SPECIFICATIONS:

MODEL NO:	AE20-48	AE20-60	AE20-72
Coring Width:	42"	54"	66"
Overall Width:	48"	60"	72"
No. of Spoon Wheels:	8	10	12
No. of Spoon Tines:	48	60	72
Weight:	245#	295#	325#



FEATURES:

- Cat. I, 3-point hitch
 - 1" Diameter main shaft
 - All-steel construction aerating wheels, temper hardened spoons
 - Oil impregnated spool wheel bearings for longer life
 - 3/4" Closed spoons, 6 spoons per wheel
 - Up to 4" coring depth, depending on soil conditions
 - Heavy steel mesh protector shield - std. on all models
 - Coring pattern - 5" x 9 1/2"
 - Options: Slicer blades in lieu of spoons
- Tow behind kit with wheels and drawbar

SPECIFICATIONS:

MODEL NO:	420	630	840
Coring Width:	39"	60"	81"
No. of Spoon Wheels:	8	12	16
No. of Spoons:	48	72	96
Weight:	300#	410#	480#



Wheels adjust hydraulically from travel-mode to coring-mode

Backhoes

3-Pt. Hitch or 4-Pt. Sub Frame Mount



**Model 365
Shown**

SPECIFICATIONS:

MODEL NO:	365	485	3509	3511
Maximum digging depth:	6' 4"	8' 5"	9' 8"	11' 1"
Digging depth (2') flat bottom:	6' 4"	8' 4"	9' 7"	11' 0"
Digging depth (8') flat bottom:	4' 4"	4' 4"	8' 3"	9' 11"
Loading height:	4' 7"	5' 3"	6' 10"	8' 0"
Loading reach:	3' 10"	4' 10"	4' 2"	5' 0"
Reach from swing pivot:	9' 0"	10' 7"	12' 9"	14' 5"
Stabilizer spread op. position:	9' 3"	7' 6"	7' 11"	7' 11"
Stabilizer below grade:	10"	10"	16"	16"
System relief valve setting:	2250 PSI	2750 PSI	2100 PSI	2100 PSI
Digging force bucket cylinder:	2599 lbs.	2895 lbs.	4768 lbs.	4768 lbs.
Digging force dipper cylinder:	1358 lbs.	2358 lbs.	2162 lbs.	2567 lbs.
Bucket rotation:	180°	180°	180°	180°
Swing arc rotation:	180°	180°	180°	180°

PTO pump kits available for 365 & 485 backhoes.

Our complete line of tractor mounted backhoes were designed with the strength and features of construction backhoes. Available in 3-point hitch or sub-frame mount; makes it easy to install when trenching projects are required. The large operator area allows for easy entry and comfortable operation.

FEATURES:

- ❑ 180° Dual-cylinder swing with internal hydraulic cushioning provides smooth operation and maximum power where it is needed
- ❑ Built from high-strength T1 steel to minimize weight and increase strength for durability
- ❑ Standard swing speed control allows the operator to adjust swing speed
- ❑ Inline filter and check valve insures longer valve life and less maintenance
- ❑ High capacity buckets provide more volume per cycle - widths from 8" to 36" depending on size of backhoe

Adjustable Thumb

Lets Your Backhoe Curl Cylinder Perform The "Clam" Action

The **Adjustable Thumb** is designed to increase the productivity and versatility of your backhoe or mini-excavator. Ideal for landscapers and contractors. Dig and load with the same machine. These rugged built thumbs fit most compact tractor backhoes, 3-point agricultural backhoes, skid steer backhoes, small excavators, and commercial backhoes. Designed to do a wide range of material handling jobs such as: land clearing, demolition work, brush removal, and pipe placement. The thumb is also handy for the loading and unloading of rocks, railroad ties, etc. A qualified welder must complete the installation.

FEATURES:

- ❑ "Claws" are made of high strength T-1 steel
- ❑ 2 Pin adjustable working position allows for handling a wide variety of material
- ❑ Folds flat against the dipper boom for storage
- ❑ Mounting requires welding unit to backhoe or mini-excavator dipperstick



**GAT-200
Shown**



Storage Position



Working Position #1



Working Position #2

SPECIFICATIONS:

MODEL NO:	GAT-50	GAT-100	GAT-200	GAT-300
For buckets measuring from pivot pin to end of teeth:	Up to 17"	18" to 22"	24" to 29"	35" to 44"
Base mounting plate:	3 1/2" x 19"	4" x 18"	5" x 21"	7" x 38"
Thumb width:	4 3/4"	5 1/2"	7 1/2"	12"
Weight:	45#	60#	110#	280#

Backhoe Manufactured by:



PALADIN LIGHT CONSTRUCTION



CAUTION: When lifting heavy objects, never exceed the lift capacity of the backhoe or mini-excavator



These **Gearmore Rear Blades** are the answer for compact tractor earth-moving requirements. They are the most versatile rear blades on the market today, as all of the standard features normally found only on large expensive rear blades, are standard on the Gearmore Rear Blade. Tilt, angle, offset, and reverse are easy to adjust so that any grading or ditching operation may be accomplished. Parking stand is now standard equipment.

SPECIFICATIONS:

Tractor HP:	Up to 30 HP	Blade Tilt:	14° to 25° Up or Down
Main Beam:	4" x 4" Steel tubing	Blade Offset:	6" Right or Left
Moldboard:	1/4" x 13" High	Cutting Edge:	1/2" x 6" Reversible
3-Point Hitch:	Category I	Weights:	Model GB5, 5' - 260#
King Pin:	2" Solid Round		Model GB6, 6' - 285#
Blade Angle:	Up to 45° Right or Left		Model GB7, 7' - 300#

These **Gearmore Rear Blades** are the answer to your mid-size tractor earth-moving requirements. These blades feature "Beam Swing" offset, which allows the heavy 4" x 4" beam to swing right or left to obtain maximum offset. Tilt, angle, offset, and reverse positions are easy to adjust so that any grading or ditching operation can be done. Parking stand is now standard equipment.

SPECIFICATIONS:

Tractor HP:	Up to 50 HP	Blade Tilt:	14° to 25° Up or Down
Main Beam:	4" x 4" Steel tubing	Blade Offset:	Up to 35" Right or Left
Moldboard:	1/4" x 16" High	Cutting Edge:	1/2" x 6" Reversible
3-Pt. Hitch:	Category I	Weights:	Model GB60, 6' - 360#
King Pin:	2" Solid Round		Model GB70, 7' - 380#
Blade Angle:	Up to 45° Right or Left		



The **Gearmore All Manual or Hydraulic Adjustment Rear Blades** are the answer to low cost, medium horsepower, earth moving requirements. These blades are easily set for beam swing offset, tilt, and angle. Change ditching or grading angles by just pulling a pin. The heavy duty design is rugged and reliable, assuring years of trouble-free use.

SPECIFICATIONS:

Tractor HP:	Up to 95 HP	Angle (man. or hyd):	Up to 50° Right or Left
3-Pt. Hitch:	Cat. 2 Clevis	Tilt (man. or hyd):	20° Up or Down
King Pin & Ped. Tube:	3" Solid Round	Offset (manual):	Up to 40" Right or Left
Main Beam:	5"x5" Steel Tubing	Cutting Edge:	1/2" x 6" Reversible
Moldboard:	1/4"x19" Box	Weights:	GB75, 7' - 770#
Offset-Swing Pivot Plt:	5/8" Thick		GB85, 8' - 800#
Parking Stand:	Fold-A-Way		GB95, 9' - 830#



The **Gearmore Hydraulic Rear Blades** are the answer to your high horsepower earth-moving requirements. These blades are available in full manual or any combination of manual/hydraulic functions. Tilt, angle, offset, and reverse positions are easy to adjust so that any grading or ditching operation can be done. The heavy duty frame is rugged and reliable, assuring years of trouble-free use.

SPECIFICATIONS:

Tractor HP:	Up to 125 HP	Blade Offset:	Up to 30" Right or Left
Main Beam:	6" x 8" Steel Tubing	King Pin Size:	4" Solid Round
Moldboard:	1/4" x 20" Box	Cutting Edge:	1/2" x 6" Reversible
3-point Hitch:	Cat. 2, Clevis	Weights:	GB800, 8' - 1105#
Parking Stand:	Fold-A-Way		GB900, 9' - 1155#
Blade Angle:	Up to 30° Right or Left		GB1000, 10' - 1215#
Blade Tilt:	14° Up or Down		



15 Series



CAT I
A.S.A.E.
QUICK
HITCH
COMPATIBLE

22 Series



CAT I
A.S.A.E.
QUICK
HITCH
COMPATIBLE

40 Series

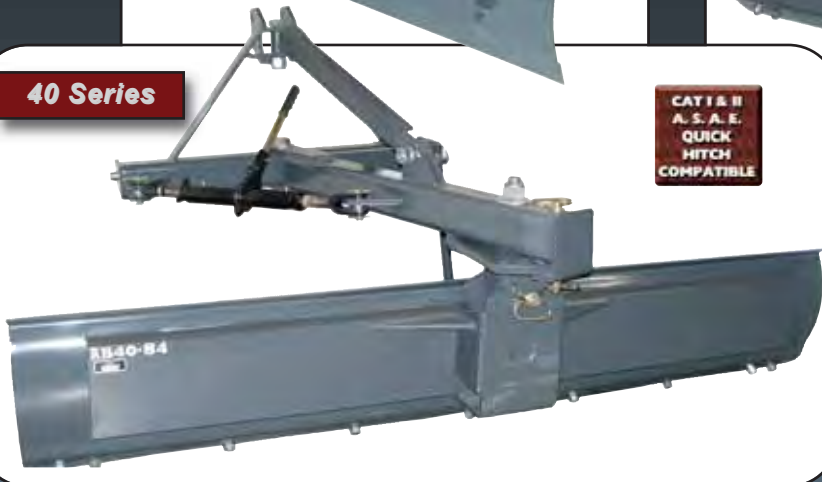

CAT I & II
A.S.A.E.
QUICK
HITCH
COMPATIBLE

Our **Rear Blades** are the ideal implement for landscaping, road and driveway maintenance, The rounded moldboards with cutting edges rolls the soil, which allows the moving of more material. The hitches are built to A.S.A.E. standards for easy hook-up to quick attach tractor systems. The unique ratchet turnbuckle allows for easy adjustment of blade offset of up to 24 inches right or left. The tilt, angle, offset, and reverse positions are all easy to adjust, so that any grading or ditching operations can be done. The heated powder coated paint keeps a quality finish for years.

FEATURES:

- Cat. 1 & 2, A.S.A.E. quick hitch compatible
- Ratchet turnbuckle adjustment for up to 24" of blade offset to right or left
- Forward and reverse angle settings
- Clevis type hitch brackets for added strength
- Rolled moldboard 15 & 22 Series - 3/16" x 15", 40 Series - 1/4" x 16"
- Heavy channel moldboard back support
- Reversible cutting edge, 1/2" x 6"
- Parking stand 40 Series - Standard, 15 & 22 Series - Optional
- Powder coated charcoal grey

SPECIFICATIONS:

MODEL NO:	15 SERIES	22 SERIES			40 SERIES		
	RB15-60	RB22-60	RB22-72	RB22-84	RB40-72	RB40-84	RB40-96
Width:	60"	60"	72"	84"	72"	84"	96"
Max. HP:	25	40	40	40	70	70	70
Angle Adj:	Up to 45°	Up to 45°	Up to 45°	Up to 45°	Up to 45°	Up to 45°	Up to 45°
Tilt Adj:	No	20°	20°	20°	Up to 25°	Up to 25°	Up to 25°
Offset Adj:	No	6" or 12", RH or LH	6" or 12", RH or LH	6" or 12", RH or LH	24" RH or LH	24" RH or LH	24" RH or LH
Cut. Edge:	Welded	Reversible	Reversible	Reversible	N/A	N/A	N/A
Cut. Edge Size:	3/8" x 3"	1/2" x 6"	1/2" x 6"	1/2" x 6"	1/2" x 6"	1/2" x 6"	1/2" x 6"
Weight:	185#	280#	300#	330#	505#	540#	580#

Hydraulic Breakers



The new Gearmore Line of Hydraulic Breakers feature the latest technology in hammer design. This simple design with only two moving parts, dual dampening blocks, low sound levels, reduces vibration and high blows per minute at lower engine R.P.M.'s makes our units the state of the art in the industry. We have 7 sizes to choose from, at energy blows in foot pound of 175 to 1250. Mounting brackets are available for most backhoes, skid steer loaders and compact excavators. Whether you are breaking up concrete, rocks or asphalt, you will finish jobs faster, safer and at less cost.

FEATURES:

- Delivers high frequency at lower engine R.P.M.
- Only two moving parts
- Has primary and secondary dampening blocks
- No bolts in base unit to reduce maintenance
- Vibro-silencing system reduces vibration to operator and machine
- Lower guaranteed sound power levels
- High quality, modern hammers at surprisingly low prices

SPECIFICATIONS:

MODELS:	G10	G20	G30	G40	G50	G60	G100
Max. Energy per Blow / ft./lbs:	175	250	450	550	750	850	1250
Required Flow / GPM:	4 - 7	5 - 10	8 - 13	8 - 16	12 - 21	14 - 26	15 - 29
Operating Pressure / PSI:	1525	1350	1600	1650	1700	1800	1800
Blows Per Minute:	650 - 1100	650 - 1150	700 - 1250	550 - 1250	650 - 1400	550 - 1200	550 - 1200
Tool Diameter / Inches:	1.60	1.80	2.10	2.60	2.75	3.00	3.75
Overall Length / Inches:	42"	46"	51"	57"	60"	63"	65"
Working Weight / lbs:	170	220	305	505	575	725	1080
Guaranteed Sound Power / db:	112	115	117	118	119	121	123
Machine Weight / lbs:	1560 - 2250	2250 - 6750	4450 - 8890	5600 - 11000	8200 - 16800	9000 - 18700	18000 - 24200

Wheel Compactors

The Economical Way For Compacting Trenches

SPECIFICATIONS:

MODEL NO:	DESCRIPTION	WHEELS	WT.
SKID STEER / TRACK LOADERS			
SSPF8	8" Compactor	1	585#
COMPACT EXCAVATORS			
CEPF8	8" Compactor	1	435#
CEPF12	12" Compactor	2	550#
CEPF18	18" Compactor	3	800#
BACKHOES			
BLPF12	12" Compactor	2	550#
BLPF18	18" Compactor	3	800#
BLPF24	24" Compactor	3	820#
BLPF36	36" Compactor	4	1195#

We now have available a complete line of compaction wheels for compact excavators, backhoes, skid steers and track loaders. All the popular widths are available in 8", 12", 18", 24" and 36". All models can be purchased in either flat pads or round pods. Standard equipment is a leveling plate to level out the soil lifts, except on skid steer compactor. Our compaction wheels are the easiest, fastest way to obtain required soil compaction.

18" Backhoe Compactor Wheel

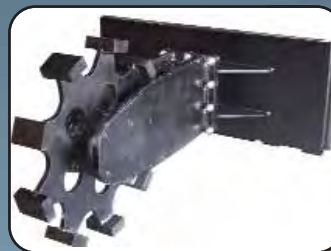

8" Skid Steer Quick Attach

FEATURES:

- Bearings are protected with outer sleeves
- Service free, factory greased bearings
- 3" x 4" x 1 1/2" thick flat pads are standard. Optional round pods are available
- 27" Diameter wheels with 9 flat pads
- 3" Diameter main shaft
- Leveling plate is standard, except on Skid Steer unit

The Gearmore pull type, PTO driven, self-feeding **Brush Processor** was designed to shred material up to 4" in diameter into a very fine mulch that will decompose in the rows without affecting your harvesting operations. The brush is fed through two hydraulic driven pick-up feed rotors into the processing chamber. The large 20" diameter rotor with fixed three tipped tungsten carbide knives shreds the brush against six rows of drop forged re-cutter bars into finer material. This mulch is then forced through a fine mesh heavy steel screen to achieve the desired size. To complete the finishing operation, we recommend the Gearmore Orchard Tiller with rear roller to bury the fine mulch 2 to 3 inches deep.

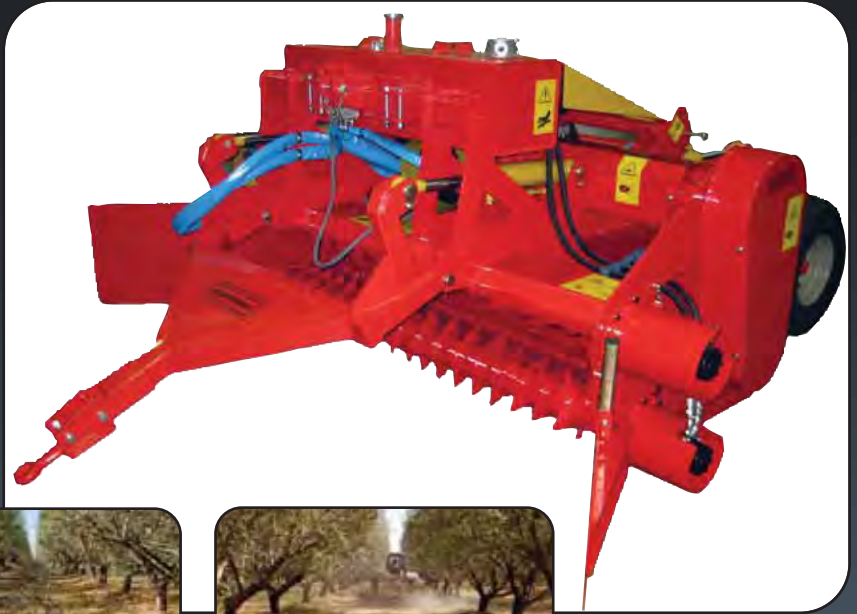

Before



After

FEATURES:

- For tractor PTO horsepower of 95 to 140
- Processes brush up to 4" in diameter into a fine decomposable mulch
- 20" Overall diameter rotor - weight 1760 lbs.
- Rotor speed - 1900 RPM
- 36 - 3-tipped tungsten carbide fixed knives
- Two pick-up feed rotors that can be adjusted independently from 50 to 200 RPM
- Rotors operate - forward & reverse from tractor seat
- Recommended tractor speed from 1 to 2 M.P.H.
- 6 Rows of drop forged fixed re-cutter bars
- Spiral knife pattern to reduce power usage
- Heavy plate screen with 3/4" x 1" diamond shaped holes for final processing
- Optional 1" or 1 1/2" diamond shaped holes
- Knives overlap 12% to give finer mulch
- 29 Gallon hydraulic oil reservoir with filter
- Oil cooler with fan
- 1000 RPM gearbox with overrunning clutch
- Heavy pull hitch adjustable w/dual hydraulic cylinders
- Drop forged adjustable towing eye
- Pair of dual rear wheels with dual hydraulic cylinders height adjustment
- 4 Wide floatation tires - 26 x 12 - 8 ply
- 7 1/2" Diameter rear roller with mud scraper
- Vented panel over the oil cooler for protection
- Two access doors to the screen interior
- Bolt-on outer flared out front gathering panels to guide brush into the processor
- Two adjustable parking stands
- 5 Final drive V-belt
- Class 8 driveshaft with 150 HP rated slip clutch
- Optional fenders

SPECIFICATIONS:

MODEL	WORKING WIDTH	OVERALL WIDTH	OVERALL DEPTH	OVERALL HEIGHT	NO. OF KNIVES	WEIGHT
WBS225	89"	10'	9' - 10"	60"	36	6500#

Effectively Chips Branches Up To 4 1/2" or 5 1/2" In Diameter



Model S520 Shown

Model S420 Shown

CAT I
A.S.A.E.
QUICK
HITCH
COMPATIBLE

These gravity or power fed **Chippers** quickly turn branches into usable mulch. The 420 chipper was developed for a maximum capacity of 4 1/2" branches and the 520 has a maximum capacity of 5 1/2" wood, as anything larger is usually considered firewood. The 4 knife flywheel was developed for smooth operation and finer cut chips. Our chippers offer a number of added value features not available from most competitive machines. These chippers are the all-in-one solution for agricultural, landscape, and property maintenance.

FEATURES - MODEL 520:

- Cat. I, A.S.A.E. quick hitch
- Speed adjustable hydraulic power feed system
- For 540 RPM tractors from 25 to 80 horsepower
- Safety bar to instantly stop, reverse, and forward the feeding of branches
- 6 1/2" Diameter power feed roll
- Steel oil reservoir tank w/replaceable oil filter canister
- 4 Reversible tool steel knives to insure smooth operation and finer cut chips
- Adjustable 4 edge tool steel bed knife
- 1 1/4" x 20" Dia. heavy 140# machined steel flywheel
- Large fixed input hopper - 27" wide by 24" deep
- Hinged blower housing cover for easy blade access
- Blower feed opening is 5 3/4" wide x 7" high
- 5" x 5" Square 360° tubing discharge chute
- Safety overrunning clutch on PTO driveshaft to prevent damage to the chipper and tractor

FEATURES - MODEL 420:

- Cat. I A.S.A.E. 3-point quick hitch
- 4 Special "chipper steel" reversible knives
- Adjustable 4 way positioning heat treated cutter bar
- Balanced flywheel plate machined from steel plate
- The top half of the chipper housing swings open and the belt guard is easily removed for maintenance
- 360° rotating 6" diameter discharge chute
- Large support stand for stability when operating chipper
- Heavy duty 540 RPM driveshaft with overrunning clutch

SPECIFICATIONS:

MODEL NO.	MIN. H.P.	NO. OF KNIVES	DEPTH	WIDTH	HT.	WT.
420	20	4	60"	45"	90"	660#
520	25	4	74"	45"	76"	770#

One Pass System For Re-conditioning Arenas



AV2-6M - Shown With Optional Mesh Roller

CAT I
A.S.A.E.
QUICK
HITCH
COMPATIBLE

**AV2-6 - Spiral Rod Roller
Arena-vator - Available
in 4 to 12 feet**



The ARENA-VATOR II was designed to renovate and condition horse arenas and tracks in a single pass. The units consist of two rows of heavy duty "S" tine shanks that vibrate in a circular motion when contacting the ground. This action loosens and cultivates a large area around the shank points. The adjustable blade then breaks down any clods and levels the soil. The new special steel mesh roller with mud scraper produces a firm, yet giving surface for even, secure footing. The fine small indentions in the soil leaves no "shadows" which could affect horses in their workouts. Units are also available with a new spiral rod roller.

Arena-Comb

Designed For Depth Control To Protect Arena Base Material

The new ARENA-COMB was developed for the highest quality arenas that usually have decomposed granite or ground rubber base under approximately 4 inches of quality sand. If the base material is disturbed the arena will be damaged. Thus, two large 8 inch wide adjustable floatation gauge wheels for depth control are mounted in the front. The two rows of heavy-duty vibrating S-tine shanks loosen and aerate the soil. The special 3/4" thick steel comb levels, gauges the depth on the rear of the machine, and finish combs the sand.

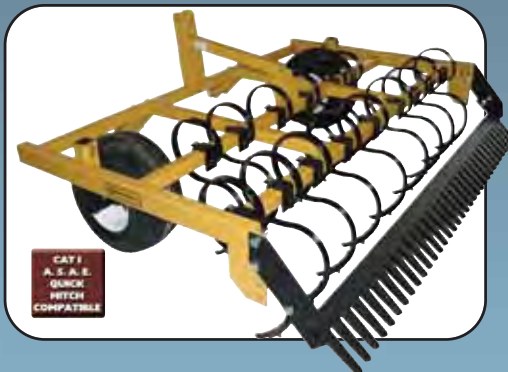

CAT I
A.S.A.E.
QUICK
HITCH
COMPATIBLE

SPECIFICATIONS:

MODEL NO.	DESCRIPTION	WT.
AC-6	6' Arena-Comb with 15 S-Tines	430#
AC-7	7' Arena-Comb with 17 S-Tines	530#
AC-8	8' Arena-Comb with 19 S-Tines	630#

FEATURES:

- ❑ Steel wire mesh 12" diameter rear roller with adjustable feature
- ❑ Units are also available with spiral rod roller plus additional widths of 10 and 12 feet
- ❑ S-tine 1 1/4" x 3/8" x 22" long with reversible and replaceable points
- ❑ Adjustable leveling blade 1/2" x 6" heat treated, beveled, and reversible
- ❑ Modern top mast
- ❑ Cat. I hitch on 4', 5', 6', & 7' models
- ❑ Cat. I & II hitch on 8' unit

SPECIFICATIONS:

MODEL NO.	DESCRIPTION	WT.
AV2-4	4' with 11 S-Tines	370#
AV2-5	5' with 13 S-Tines	500#
AV2-6	6' with 15 S-Tines	575#
AV2-7	7' with 17 S-Tines	640#
AV2-8	8' with 19 S-Tines	775#

Add "M" to model number for mesh roller units

FEATURES:

- ❑ Cat. I, 3-point hitch
- ❑ Heavy 3 bar frame
- ❑ Two large adjustable 8" wide gauge wheels with 18.5 x 8.5 floatation tires
- ❑ Two rows of 1 1/4" x 3/8" x 22" S-tine vibrating spring shanks
- ❑ Heat treated reversible shank points
- ❑ Special 3/4" thick rear finishing comb

The Only In-Row Implement Designed For Year Round Maintenance

Multi-Purpose In-Row Implement For Row Vineyards

The one implement available on the market for in-row maintenance all year long. The Spedovator with Power Disc will knock down berms and removes tall weeds; the Back Fill Blade will rebuild the berms; the Power Harrow and Rotary Tiller will remove weeds and till the soil; the In-Row Blade will control light weeds; the Flail Shredder mows in-row grass when planted to prevent erosion; and the Shoot Remover will remove unwanted shoots. All tools hydraulically retract with a highly sensitive feel arm to prevent damage to the plants.

"Perfect for Organic Growers"

Model R5115 shown with optional Power Disc

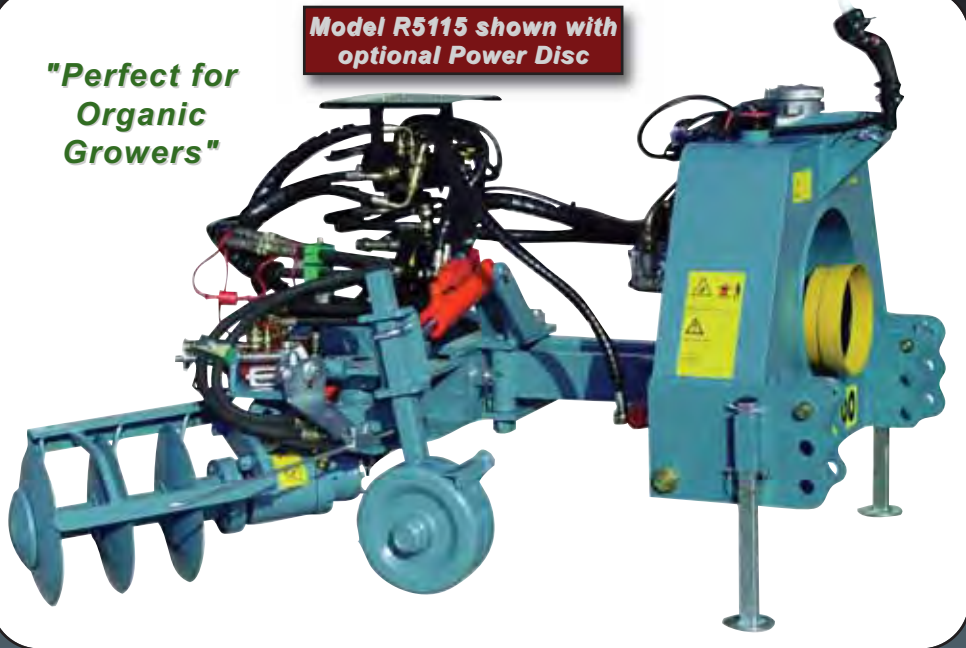

Base unit consists of:

Cat. I & II 3-Point hitch, gauge wheels, 4 spool valve, PTO pump, reservoir, hydraulic side shift, remote tool lifting system and hydraulic sensing system that automatically retracts the 8 different tools.

MODEL NUMBER	OFFSET - 3 BLADE UNIT	INCHES	INCHES	INCHES	MIN. H.P.
ALL MODELS	30" Min.	60" Min.	20" Min.		30
* Designed to work 5 to 8 foot rows with tractor centered on the row.					

8 IN-ROW MAINTENANCE TOOLS TO ELIMINATE THE USE OF CHEMICALS



Power Disc



Power Harrow •



Back Fill disc



Rotary Tiller •



In-Row Blade



Rotary Hoe •



Flail Shredder •



In-Row Blade

Ready For 2 1/4" Diamond Bar Mounting

- Tools that require double pump units with oil coolers for operating tools effectively. Available with electro or hydraulic controls.

Post Hole Diggers

3 Digger Models To Match Your Tractor Horsepower



D40 Shown



Standard Duty Augers



Pengo Boring Head Augers

FEATURES:

- Tubular steel construction
- Shear pin drive
- 2" Output shaft
- Replaceable fishtail auger point
- Rugged 540 RPM gearbox
- Fully shielded drive shaft, gearbox & auger collar
- Semi double flighting augers

- Standard duty Gearmore augers with bolt-on teeth
- PENGO**® augers with *TriMax*™ heavy duty cast steel boring head and Tri-Flow® pilot bit

SPECIFICATIONS:

MODEL	H.P.	CAT.	BOOM LENGTH	MAXIMUM AUGER DIA.	AUGER LENGTH	WT.
D20	20 H.P.	1	45"	12"	34"	120#
D40	40 H.P.	1	62"	12"	40" & 42"	170#
D60*	60 H.P.	1 & 2	70"	24"	45" & 48"	200#

* D60 Digger now available with hydraulic down force kit.

Tractor Quick Hitches

The Quick, Safe Way To Attach Implements



CAT. I

CAT. II

Our Cat. I & II **Quick Hitches** were designed to make changing implements easier, safer and faster. Thus eliminating the lifting and moving heavy implements into position for mounting to the tractor. You can safely change implements in seconds.

FEATURES:

- Operator can engage and secure implements from the tractor seat
- Reduces chance of personal injury as no need to put yourself between the tractor and the implement, except for attaching driveshafts
- Automatic lock with quick release handles
- Heavy all steel construction
- Optional hydraulic top link cylinders are available for easier hook-up
- Additional bushing kits for each implement are available

Strongly recommend ordering optional hydraulic top link cylinder, as it greatly aids aligning to implement 3-point hitch when not "parked" perpendicular to the ground.

SPECIFICATIONS:

MODEL	DESCRIPTION	WT.
GQH-1	Cat. I Quick Hitch - Complete with 7/8" shouldered bushings and swivel yoke	75#
GQH-2	Cat. II Quick Hitch - complete with 1 1/8" mounting pins & adapter bushings - 100 HP Max.	135#

SPECIAL NOTE: *Some implement manufacturers do not build to ASAE standards. Always check with your dealer to make sure the implements you order will fit the ASAE quick hitch.*

7 Sizes Of Hydraulic Diggers Available So You Can Match To Your Tractor GPM

The "X" Series is the most trouble free hydraulic digger on the market today. These diggers feature an "in-line" sealed planetary gear reduction drive design. This clean, effective system ensures long, trouble free usage. All "X" Series models feature reverse rotation for quick backout when obstructions are encountered. The systems hydraulic relief valve protects the digger from damage when an auger hits large immovable objects.

X SERIES

FEATURES:

- ❑ 7 Models to match tractor GPM's from 5 to 60
- ❑ All units feature planetary gear reduction, except D450
- ❑ High torque motors ensure digging through the toughest of conditions
- ❑ Adapter plate mounting on most popular skid steers, backhoes, loaders, etc.
- ❑ 2 Models of augers designed to match your soil conditions



SPECIFICATIONS:

MODEL NO:	D450	X975	X1475	X1975	X2475	X4075	X5075
Min. Hyd. Flow GPM:	5	6	10	15	20	24	28
Max. Hyd. Flow GPM:	10	15	25	30	35	32	40
Max. Auger Diameter:	12"	24"	30"	36"	36"	48"	48"
Output Shaft Options:	2" Round	2 9/16" 2" Hex	2 9/16" 2" Hex	2 9/16" 2" Hex	2 9/16" 2" Hex	2" Hex	2" Hex

HIGH QUALITY CONSTRUCTION AUGERS

MEDIUM DUTY - "HDF" STYLE AUGERS

For Light To Moderate Ground Conditions



STD "HDF" FEATURES:

- ❑ Fabricated Boring Head
- ❑ Hardened Bolt-on Teeth
- ❑ Hardened Fishtail Point
- ❑ HD Double Flighting
- ❑ Collars - 2" round, 2 9/16" round and 2" hex
- ❑ Available in 3', 4', 5' & 6' lengths
- ❑ Stocked in 4' length

Dia.	Tooth Qty.
4"	N/A
6"	2
8"	2
9"	3
10"	3
12"	4
15"	5
16"	5
18"	6
20"	6
24"	8
30"	9
36"	11

HEAVY DUTY - "HDC" STYLE AUGERS

For Difficult Ground Conditions



STD "HDC" FEATURES:

- ❑ HD Cast Steel Boring Head
- ❑ Hardened Drive-in Teeth
- ❑ Hardened Fishtail Point
- ❑ HD Double Flighting
- ❑ Collars - 2" round, 2 9/16" round & 2" hex
- ❑ Available in 3', 4', 5' & 6' lengths
- ❑ Stocked in 4' length

Dia.	Tooth Qty.
6"	2
8"	4
9"	4
10"	4
12"	4
15"	6
16"	6
18"	6
20"	6
24"	8
30"	10
36"	12

ROCK AUGERS - "HDR" STYLE AUGERS

For Solid, Frozen Ground & Compacted Soils

Dia.	Tooth Qty.
6"	6
9"	8
12"	12
18"	18

STD "HDR" FEATURES:

- ❑ Bullet Style Teeth & Fabricated Boring Head
- ❑ HD Single Flight - 3/4" Thick Bottom Flight
- ❑ 2" Hex Collar ONLY
- ❑ Available in 4' Length
- ❑ Hardfaced Outer Edge

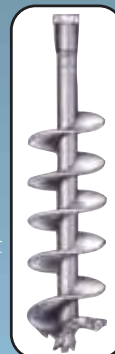

Auger extensions available in 2" & 2 9/16" round and 2" hex in lengths of 24", 48", & 72"

Manufactured by:

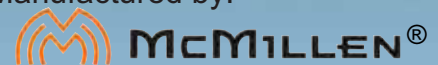

PALADIN LIGHT CONSTRUCTION

"C/D" Series



FEATURES:

- Cat. I, 3-Point hitch
- 7" Blade spacing
- Triple sealed ball bearings
- Adjustable front and rear gangs
- 1 1/8" Square high carbon axles
- 18" Notched front and plain rear blades
- Heavy quick hitch mast

SPECIFICATIONS:

MODEL NO.	CUTTING WIDTH	APPROX. H.P. REQ'D	NO. OF BLADES	WEIGHT
C1218	42"	14 HP	12	375#
C1418	48"	16 HP	14	420#
C1618	54"	18 HP	16	480#
D1818	60"	22 HP	18	620#
D2018	66"	24 HP	20	670#

"GO" Series

FEATURES:

- Cat. II, 3-point hitch
- Frame has 2" x 4" and 4" x 4" tubing
- 24" Notched front and plain rear blades
- 9" Blade spacing
- 1 1/2" Square gang axles
- Flange mounted, triple sealed bearings
- Adjustable rear gang and 3-point hitch
- Steel spacer spools



SPECIFICATIONS:

MODEL NO.	CUTTING WIDTH	NO. OF BLADES	WEIGHT
GO24-60	6' - 0"	16	1120#
GO24-69	6' - 9"	18	1170#
GO24-76	7' - 6"	20	1405#
GO24-83	8' - 3"	22	1560#
GO24-90	9' - 0"	24	1600#

"Light Duty"

FEATURES:

- ❑ Cat. I, 3-Point hitch
- ❑ 7" Blade spacing
- ❑ Triple sealed ball bearings
- ❑ Adjustable front and rear gangs
- ❑ 1 1/8" Square high carbon axles
- ❑ 18" Notched front and plain rear blades



SPECIFICATIONS:

MODEL NUMBER	CUTTING WIDTH	APPROX. H.P. REQ'D	NO. OF BLADES	WEIGHT
T1618	60"	18 HP	16	525#
T2018	72"	22 HP	20	630#
T2418	84"	26 HP	24	695#

"Medium Duty"



FEATURES:

- ❑ Cat. I, 3-pt. hitch, w/3" square tubing frame
- ❑ Notched front and plain rear, high carbon blades
- ❑ Heavy cast blade spools
- ❑ Sealed bearings provide superior performance
- ❑ Easy, quick angle adjustments of 16°, 30°, 44° & 57°

SPECIFICATIONS:

MODEL NUMBER	CUT. WIDTH	BLADE DIA.	NO. OF BLADES	WT.
18-16-CBF	60"	18"	16	760#
20-20-CBF	72"	20"	20	820#
20-24-CBF	84"	20"	24	880#

"Heavy Duty"

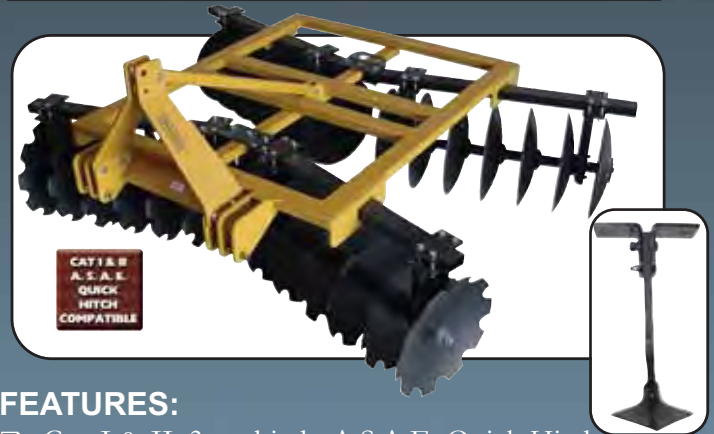

FEATURES:

- ❑ Cat. I & II, 3-pt. hitch, A.S.A.E. Quick Hitch
- ❑ 3/16" x 22" Notched front and plain rear blades
- ❑ Easy gang adjustment with special pull handles
- ❑ Front and rear gangs adjustable to 7°, 14° or 21°
- ❑ 1 1/8" High carbon square axles
- ❑ 7 1/2" Long cast spool spacers
- ❑ Optional: Bolt-on center mtd. shank w/6" sweep

SPECIFICATIONS:

MODEL NUMBER	CUT. WIDTH	BLADE DIA.	NO. OF BLADES	WT.
T1622	5' - 6"	22"	16	1100#
T2022	6' - 6"	22"	20	1230#
T2422	7' - 6"	22"	24	1515#
T2822	8' - 6"	22"	28	1660#
T3222	9' - 6"	22"	32	1760#

Tandem, Narrow Row - "GV" Series



Narrow row crops like grapes, berries, pole tomatoes, etc., also require heavy duty tillage tools. Our new **Narrow Row Tandem Disc** fits those requirements. This disc is excellent for knocking down weeds, leveling and mixing in residue. The 22" diameter notched front blades aid in cutting through hard soils, while the rear smooth blades give a smooth finish. Flange mounted, double sealed, shielded bearings. A number of options are available, such as: dirt shield fenders, extension blades, bearing guards, special low position 3-point hitch.

SPECIFICATIONS:

MODEL NUMBER	ROW WIDTH	NO. OF BLADES	FRAME WIDTH	CUTTING WIDTH	WEIGHT
GV-5R	5' (60")	8	48"	32" to 44"	1200#
GV-6R	6' (72")	12	57"	56" to 62"	1420#
GV-8R	8' (96")	16	75"	68" to 80"	1745#

Tandem, Reversible - "GRT" Series



Our heavier duty series of **Reversible Vineyard Discs** were designed for maximum strength and durability. The frame was built with heavy wall tubing for additional weight in tough soil conditions. The disc has 24" diameter plain blades front and rear. The 3-point hitch is Cat. II quick hitch. The reversible hitch can easily be re-mounted on the opposite end of the disc when required.

SPECIFICATIONS:

MODEL NUMBER	CUTTING WIDTH	NO. OF BLADES	WEIGHT
GRT24P-HD-16	5' 8" to 7'	16	2160#
GRT24P-HD-18	7' 2" to 8' 6"	18	2260#
GRT24P-HD-20	7' 2" to 8' 6"	20	2490#

Manufactured by:

BWImplement

Two Popular Series of Medium Duty Pull Type Discs

Narrow Tandem Discs - "VWT" Series

FEATURES:

- FRAME:** 4" x 4" x 1/4" Structural tubing
- GANG FRAME:** Fully adjustable front to rear
- HITCH:** Self leveling, spring cushioned with hand crank
- BEARINGS & AXLES:** 1 1/2" Square axles with trunnion mount triple lip sealed greaseable bearings with wear shield
- BLADES:** 24" x 4.5 mm smooth blades
- SPOOLS:** 9" Steel spacer spools and cast iron half spools
- HYDRAULICS:** 3 1/2" x 8" Cylinder with depth control
- SHANK:** 1" x 3" Center shank with adjustable footpiece
- WHEEL & TIRE:** 6 Bolt hub and spindle assemblies with 9.5L x 15" 8 ply tire



SPECIFICATIONS:

MODEL NO.	CUT. WIDTH	NO. OF BLADES	WT.
VWT24-16	5' 8" - 7' 0"	16	2480#
VWT24-18	7' 2" - 8' 6"	18	2600#
VWT24-20	7' 2" - 8' 6"	20	2680#
VWT24-22	8' 8" - 9' 8"	22	2720#
VWT24-24	8' 8" - 9' 8"	24	2800#

Wide Tandem Discs - "GT" Series



FEATURES:

- FRAME:** 4" x 4" x 1/4" Structural tubing
- HITCH:** Self leveling, spring cushioned with hand crank
- GANGS & BEARINGS:** 1 1/2" Square gang axles with greaseable trunnion mounted, triple sealed bearings with wear guards
- GANGS:** Adjustable - front 12° to 22° - rear 9° to 21°
- BLADES:** 24" x 6mm notched front & plain rear - 9" spacing
- SCRAPERS:** Standard, adjustable individually or by gang
- WHEELS & TIRES:** 2 - 6 Bolt hub and spindle assy. 2 - 9.5L x 15" 8-ply tires
- HYDRAULICS:** 3 1/2" x 8" Cylinder with depth control and hoses
- REAR HITCH:** Standard equipment

SPECIFICATIONS:

MODEL NUMBER	CUTTING WIDTH	NO. OF BLADES	NO. OF WHEELS	WT.
GT-24T	9' - 2"	24	2	3300#
GT-28T	10' - 8"	28	2	3700#
GT-32T	12' - 2"	32	4	4140#
GT-36T	13' - 8"	36	4	4360#
GT-40T	15' - 2"	40	4	4800#
GT-44T	16' - 8"	44	4	5130#
GT-48T	18' - 2"	48	4	5610#

Manufactured by:

BWI Implement

Excellent General Purpose Offset Wheel Discs

Offset, Pull Type Discs - "300" Series

SPECIFICATIONS:

MODEL NO.	WIDTH	NO. OF BLADES	H.P. REQ'D	WT.
G301	4' - 6"	12	35-45 HP	1300#
G302	5' - 3"	14	35-45 HP	1400#
G303	6' - 0"	16	40-55 HP	1500#
G304	6' - 9"	18	40-55 HP	1600#
G305	7' - 6"	20	45-60 HP	1700#
G306	8' - 3"	22	50-65 HP	1800#
G307	9' - 0"	24	55-70 HP	1900#
G308	9' - 9"	26	60-75 HP	2000#



The **Gearmore 300 Series Offset Discs** are ideal for light and medium tillage conditions. We offer sizes from 4'-6" to 9'-9"; for vineyards, berries, narrow row orchards, general field cultivation, etc. The offset design enables maximum penetration and even tillage of soil. Heavy construction with 4" x 3" x 1/4" frame, 1 1/4" axles, 22 inch diameter blades in notched or smooth, self leveling hand crank, and triple sealed bearings. Built in the West for tough, western conditions.

Offset, Pull Type Discs - "500" Series

The **Gearmore Low Profile Offset Discs** are of rugged design for deep tilling in all soil conditions. We offer the most popular widths of 8'-3" to 10'-6", for orchard and general tillage operations. The offset design enables maximum penetration and even tillage of soil. Heavy construction with 1 1/2" square gang axles, 24 inch diameter blades in notched or smooth, self leveling hand crank and trunnion mounted, sealed bearings. Built in the West for tough, western conditions.



SPECIFICATIONS:

MODEL NO.	CUTTING WIDTH	NO. OF BLADES	FRAME	NO. OF WHEELS	TRACTOR HP REQ'D	WT. PER FOOT	WEIGHT
G503	8' - 3"	22	4" x 4" x 1/4"	2	60 to 80	335 lbs.	2800#
G504	9' - 0"	24	4" x 4" x 1/4"	2	65 to 85	345 lbs.	3100#
G505	9' - 9"	26	4" x 4" x 1/4"	2	70 to 90	370 lbs.	3600#
G506	10' - 6"	28	4" x 6" x 1/4"	4	75 to 100	390 lbs.	4100#
G507	12'	32	4" x 6" x 1/4"	4	80 to 120	400 lbs.	4800#

Manufactured by:

BWImplement

Excellent For Heavy Duty Tillage Operations

Offset, Wheel Type - "700" Series



The Gearmore Heavy Duty Offset Finisher Discs are of rugged design for finish tilling in all soil conditions. We offer the most popular widths of 15'-6" to 22'-3", for general tillage operations. The offset design enables maximum penetration and even tillage of soil. Heavy construction with 1 1/2" square gang axles, 26 or 28 inch diameter blades in notched and smooth, self leveling hand crank, and trunnion mounted sealed bearings. Built in the West for tough, western conditions.

SPECIFICATIONS:

MODEL NUMBER	CUTTING WIDTH	NO. OF BLADES	FRAME	NO. OF WHEELS	TRACTOR H.P. REQ'D	WT. PER FOOT	WEIGHT
G704-9	15' - 6"	42	6" x 8"	4	80 to 150	610 lbs.	9,140#
G705-9	16' - 0"	44	6" x 8"	4	90 to 160	580 lbs.	9,220#
G711-9-F	18' - 0"	48	6" x 8"	4	130 to 170	600 lbs.	10,800#
G712-9-F	20' - 9"	56	6" x 8"	4	150 to 185	605 lbs.	12,465#
G714-9-F	22' - 3"	60	6" x 8"	4	190 to 220	580 lbs.	12,700#
G716-9-F	23' - 9"	64	6" x 8"	4	200 to 225	550 lbs.	13,000#

"F" stands for folding models - other widths available upon request

Offset, HD Wheel Type - "900" Series

SPECIFICATIONS:

MODEL NUMBER	CUTTING WIDTH	NO. OF BLADES	H.P. REQ'D	WEIGHT
G903	14' - 2"	26	145 to 235	12,150#
G904	15' - 3"	28	160 to 250	12,530#
G905	16' - 4"	30	170 to 265	13,200#
G906	17' - 5"	32	180 to 280	13,600#
G907	18' - 6"	34	190 to 285	14,850#

FRAME & TONGUE: 4" x 8" Structural tubing
HITCH: Hydraulic adjusted for easy tractor hook-up
GANGS & BEARINGS: 2 1/4" Square gang axles with greaseable trunnion mounted, triple sealed bearings with additional external seals
GANG BEAMS: 8" x 8" Structural tubing
BLADES: 32" Dia. x 9.5 mm notched front and rear with 13" spacing
SCRAPERS: Heavy duty high tensile steel
WHEELS: Dual w/8 bolt hubs & spindles
TIRES: 4 - 12L x 15 8-Ply

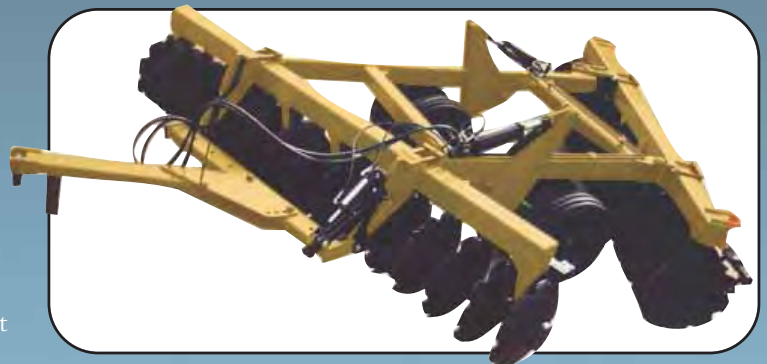

Manufactured by:

BWI Implement

Offset Scissor Discs

With Hydraulic Angle Adjustment



Our offset scissor discs feature "on the go" hydraulic angle adjustments from 0 to 45 degrees. The disc has front and rear notched shallow concavity blades which are 32" diameter by 3/8" thick. The greaseable dual tapered roller bearings insure long life. The gang bearings are protected with heavy duty wear plates with chrome hard facing to greatly reduce wear. Gang axles are 2 1/4" square which locks the blades better in place than round axles. The 4 large 12.5L x 16-14 Ply tires give stability when transporting the disc. Other standard features are 26" furrow filler, blade scraper, tongue jack, and light group.



FEATURES:

- Scissor action hydraulically adjusts "on the go" from 0 to 45 degrees
- Blades are 32" x 3/8" thick notched shallow concavity
- Heavy adjustable mud scrapers
- 2 1/4" Square gang axles
- Greaseable dual tapered roller bearings
- Bearing housing protected with replaceable chrome wear plates
- Gang beams - 6" x 8" heavy wall tubing
- Gang spacers - 18" wide steel spools
- 26" Diameter notched furrow filler disc blades
- 4" x 8" Heavy wall tubing tongue adjusts horizontally and vertically
- Double swivel tongue hitch
- 4 - 12.5L x 16 - 14 Ply tires
- Hydraulic wheels with safety lockout brackets
- Tongue jack is standard
- Slow moving sign is standard
- Light group is standard
- Standard blades - optional

SPECIFICATIONS:

MODEL NUMBER	WIDTH OF CUT	NO. OF BLADES	P.T.O. HP REQUIRED	WT. PER BLADE	WT.
G1000-16	16' - 0"	22	240 - 300 HP	520 lbs.	11,400#
G1000-17-6	17' - 6"	24	300 - 400 HP	520 lbs.	12,500#
G1000-20-6	20' - 6"	28	400 - 450 HP	535 lbs.	15,000#

Manufactured by:

BWImplement

The **Gearmore Mini Duster** is a simple all gear drive unit. The dust is accurately applied with easy to set application rates. A mechanical agitator insures even flow of material. The wind velocity of 150 M.P.H. achieves maximum coverage. This economy duster is just right for use in narrow vineyard, berries, and other pole crops such as snow peas.

FEATURES:

- Requires only 15 PTO Horsepower to operate
- All gear drive for low maintenance
- Mechanical agitation for even flow
- High wind velocity for maximum coverage
- Adjustable distribution nozzles



**Model S420
Shown**

Gearmore Dusters combine simple design with quality craftsmanship. The all-gear drive provides maximum performance with low maintenance. Sulfur is accurately applied with easy to set application rates. The model S530, with a large 400 lb. capacity poly hopper and extended fishtail distributors, is preferred by growers with wide row spacings. The model S420 with 300 lb. capacity poly hopper is the perfect machine for vineyards with narrow row spacings.

FEATURES:

- Polyethylene hopper and cover
- Wrap-A-Round tubular steel frame isolates and supports hopper
- All gear drive for low maintenance
- Mechanical agitation for even flow
- Wind velocities up to 180 M.P.H. for maximum coverage
- Manual rate control allows for setting the pounds per acre
- Adjustable fishtail nozzles

SPECIFICATIONS:

MODEL	HOPPER CAPACITY	FAN DIA.	WIND VELOCITY	3-POINT HITCH	WIDTH	HEIGHT	DEPTH	FISHTAIL EXT.	WIDTH w/ FISHTAILS	WT.
G2V	150 lbs.	12"	150 M.P.H.	Cat. 1	17"	42"	24"	D.N.A.	40"	100#
S420	300 lbs.	15 3/4"	150 M.P.H.	Cat. 1	37"	48"	48"	Optional	37"	230#
S530	400 lbs.	19 3/4"	180 M.P.H.	Cat. 1 & 2	37"	58"	48"	Yes	72"	310#
S530N*	400 lbs.	19 3/4"	180 M.P.H.	Cat. 1 & 2	37"	58"	48"	No	37"	300#

* Same narrow fishtails as S420

"NEW"



Our Trailer Duster now features new attachments as standard equipment. An electro hydraulic cylinder with control box for adjusting flow rate from the tractor. Also, a hydraulic motor to control the speed of the full length spiral conveyor and agitation system. This insures uniform, accurate distribution of the dust. The high 1000 pound capacity hopper insures maximum coverage between fill-ups. The duster is compact and easy to maneuver even in narrow rows.

FEATURES:

- Heavy gauge steel hopper with up to 1000# capacity
- Large hopper opening and hinged lid for easy re-fill
- High performance, precision balanced, all-steel centrifugal turbine fan
- Built-in overrunning clutch protects the drive train
- Swivel distribution nozzles adjust for vines and trees
- Full hopper length, large diameter agitator feeds spiral conveyor in bottom of hopper
- Tongue length and tire width are adjustable
- Heavy duty clevis hitch
- Screw adjustment tongue jack
- Wide angle constant velocity driveshaft
- Adjustable rear bumper shields the distribution heads from impact and possible damage
- All steel parts are undercoated with anti-corrosive paint and finish coated
- Application rates from 5 to 100 lbs. per acre
- Special domed trash screen
- For 540 RPM tractors



SPECIFICATIONS:

MODEL	CAPACITY	MIN. H.P.	VOLUME OF AIR	AIR SPEED	HEIGHT	WIDTH	LENGTH	TIRES	WT.
MAXI 600-SPC	1000 lbs.	40 H.P.	3180 C.F.M.	420 MPH	50"	50" to 68"	110"	9.5L x 15 - 8 Ply	940#

Row Crop Sulfur Duster

Dust Is Metered Directly Into High Speed Turbine Fan To Insure Total Even Coverage

With Hydraulic Folding Boom

Gearmore Row Crop Sulfur Dusters combine simple design with quality craftsmanship. The all-gear drive provides maximum performance with low maintenance. Dust is accurately applied with easy to set application rates. The large 400 lb. capacity polyethylene hopper allows dusting of many acres between "re-fills".

The booms are available for 5 to 12 rows with adjustable nozzles to insure accurate dust placement on the plant foliage. Our Row Crop Sulfur Dusters have successfully controlled mildew on strawberries, tomatoes, watermelons, pumpkins, cantaloupes, peppers, cucumbers, and many other crops.

If you are an organic grower, dusting with sulfur will not affect your organic status.

DUSTER FEATURES:

- Cat. I & II, 3-point hitch
- 400 Pound capacity polyethylene hopper with hinged vented cover
- Wrap-A-Round tubular steel frame isolates and supports hopper
- Aluminum fan housing and steel fan
- All gear drive for low maintenance
- Wind velocities up to 180 M.P.H. at manifold
- Manual rate control allows for setting the pounds per acre
- Mechanical agitation for even flow
- Lever control, reachable from tractor seat, allows operator to turn the dust on and off
- Optional parking stands for high clearance tractors (ground to hitch pins - 23")

Sulfur has been proven to be the most effective way to control powdery mildew

5 Row Shown w/Optional Parking Stands

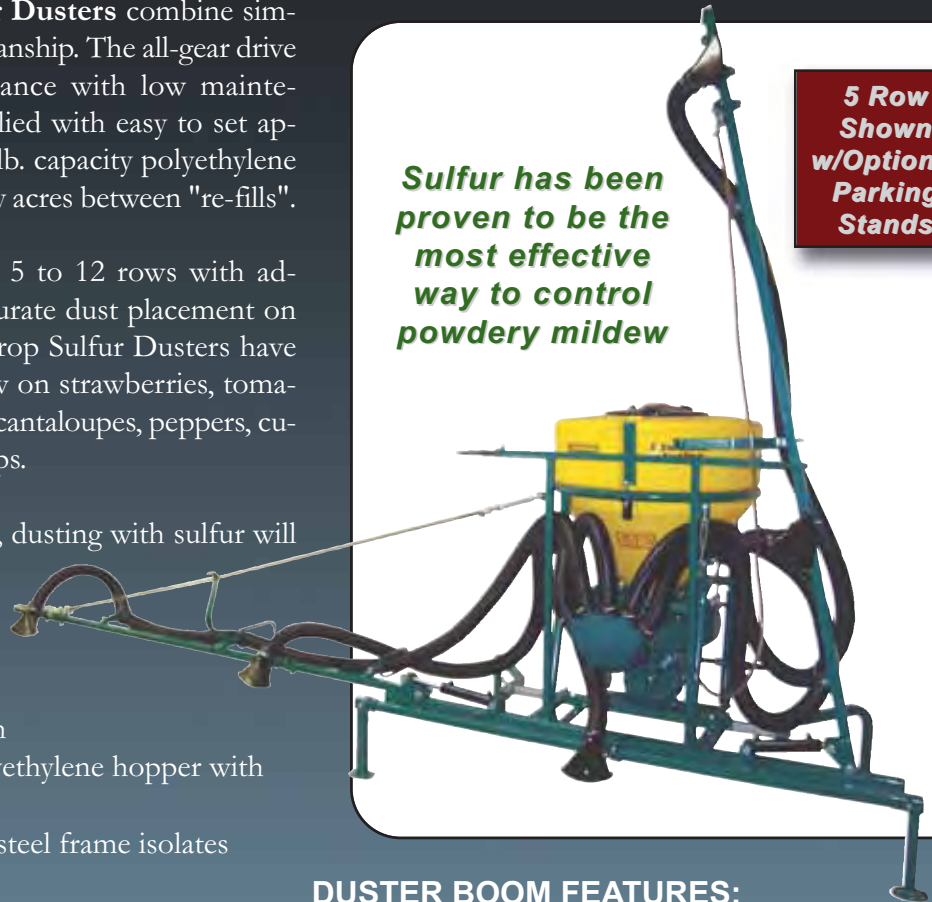

DUSTER BOOM FEATURES:

- Available in 5, 10, & 12 row, hydraulic foldaway booms
- Steel frame that easily bolts to duster frame
- Adjustable nozzles allows for angling to the foliage
- Wide spread fishtail shaped nozzles for better coverage
- 2 3/4" I.D. flexible black hose

SPECIFICATIONS:

MODEL NO.	DESCRIPTION	BOOM LENGTH	MAX. NOZZLE CENTERS	WEIGHT
S530B-5HF	5 Row Duster	31' - 2"	68"	400#
S530B-10HF	10 Row Duster	31' - 2"	40"	460#
S530B-10HF-3MT	10 Row Duster	41' - 2"	48"	470#
S530B-12HF-3MT	12 Row Duster	41' - 2"	40"	500#

3-Point Mounted

ECONOMY FORKS
Model 1200



STD. DUTY FORKS
Model 1500 & 2000-3PT



ADJ. TINE FORKS
Model 1500AT

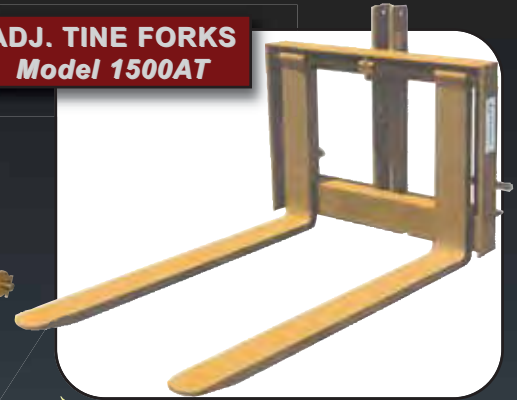

ADJ. TINE FORKS
Model 3548



SPECIFICATIONS:

MODEL NUMBER	CAP.	FORK WIDTH (center to center)	FORK THICKNESS	FORK LENGTH	WT.
1200	1200 lbs.	26"	2" x 4" x 3/16" tube	41"	90#
1500 QH	1500 lbs.	26"	1" x 4" solid	41"	160#
2000-3PT QH	2000 lbs.	26"	1 1/4" x 4" solid	41"	180#
1500AT	1500 lbs.	5" - 26"	1 1/4" x 4" solid	41"	290#
3548 Cat. 2	3500 lbs.	10" - 36"	1 3/4" x 4" solid	48"	315#

Bucket Forks

Turns Your Loader Bucket Into A Forklift

The Gearmore Bucket Forks allows you to turn your tractor into a forklift in seconds. Our simple safety lock brackets are welded to your bucket. You then curl down the bucket and drive into the forks. Next level the bucket and the forks lock into place.

FEATURES:

- Mounts to your loader bucket in seconds
- Patented forming process increases the bend and heel thickness by 20%
- Tines made of special boron steel and fully heat treated after bending
- Heavy plate mounting brackets
- Rods made of 4140 ground and polished, high carbon steel
- Extra long tine taper for easier load entry
- Adjustable tine spacing
- Forks have a safety rating of 3 times the stated capacity (except 1200# forks)



Safety Lock System

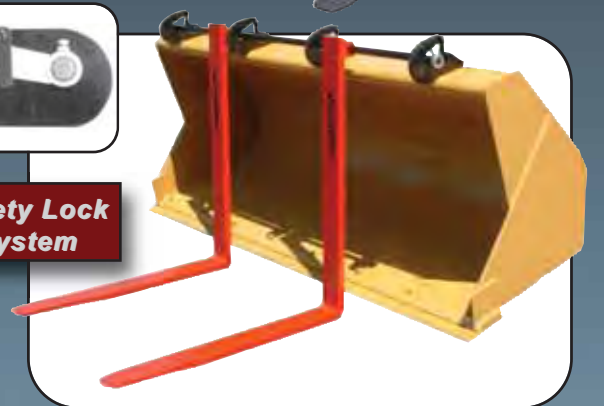

SPECIFICATIONS:

MODEL NO:	12 UNIV	25 UNIV	40 UNIV	60 LB	60 UNIV	80 UNIV	110 UNIV*
Max. Load Cap.	1200 lbs.	2500 lbs.	4000 lbs.	6000 lbs.	6000 lbs.	8000 lbs.	11000 lbs.
Tine Center:							
Fits Bucket	23"	32"	40"	40"	49"	54"	67"
Opening up to:							
Tine Height**:	31"	38"	46"	46"	55"	61"	73"
Tine Length:	36"	36"	42"	46"	46"	48"	60"
Adj. Width:	60"	60"	72"	72"	72"	72"	84"
Weight:	185#	240#	330#	400#	435#	690#	960#
Rod Size:	1 1/4" x 5'	1 1/4" x 5'	1 1/4" x 6'	1 1/2" x 6'	1 1/2" x 6'	1 3/4" x 6'	2" x 7'
Tine Size:	1" x 4"	1 3/8" x 4"	1 3/8" x 4"	1 3/4" x 4"	1 3/4" x 4"	2" x 5"	2" x 6"
No. of Brkts:	3	3	4	4	4	4	4

* By adding a third tine, a 16,500 lb. capacity unit is available and by adding a fourth tine, a 22,000 lb. capacity unit is available.

** Deduct 2" to calculate center of rod bushing height.

Bucket Forks

SPECIFICATIONS:

MODEL NO.	CAPACITY LBS.	FORK DIMENSION	WEIGHT
1000	1000 lbs.	2" x 3" x 32"	90#
2000	2000 lbs.	2" x 3" x 36"	110#
3000	3000 lbs.	2" x 4" x 42"	150#
4000	4000 lbs.	2" x 4" x 42"	170#
6000	6000 lbs.	3" x 5" x 48"	275#



Quick, easy way to make your loader bucket into a forklift. Mounts in seconds to most loader buckets without tools. Forks are equipped with handles for ease in mounting and spacing adjustments. Both forks now have baked-on powder coated paint for rust-free durability and long lasting glossy finish.

Trash Forks

SPECIFICATIONS:

MODELS:	GTF48	GTF54	GTF60	GTF66	GTF72
Bucket Size:	48"	54"	60"	66"	72"
Width:	46"	52"	58"	64"	70"
Tines:	5	5	6	6	7
Approx. Spacing Between Tines:	8 1/2"	10"	8 1/2"	10"	9"
Weight:	160#	170#	180#	195#	210#



If loader buckets are equipped with bolt-on cutting edges, both the forks on this page are available with wide opening, just add **W** to model number.

FEATURES:

- 2 Heavy screw-lock clamp brackets w/zinc plated handle/screw assemblies
- 2" Square, 1/4" wall tubing by 20" long tines
- Clamps fit deep into the bucket for added strength
- Clamping brackets placed near bucket side plates for added strength

A loader bucket is great for moving soil, but handling trash is a problem. Our Trash Forks are an economical and easy mount solution to this problem. This handy tool will make moving tree branches and other debris an easy task.

Bale Spears

These Clamp-on Bucket Bale Spears are a quick and handy tool to convert your loader bucket into bale spears. The units have a capacity of 3000 pounds and can handle square or round bales.

FEATURES:

- Spear length - 41"
- Spear diameter - 1 5/8"
- Overall length - 56"
- 1 1/4" Opening for bucket cutting edge

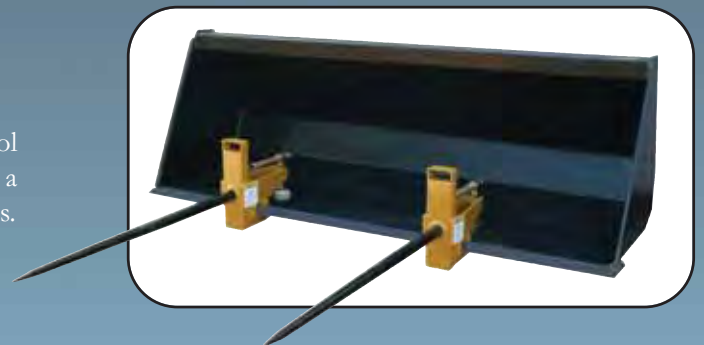

SPECIFICATIONS:

MODEL #	DESCRIPTION	CAPACITY	WT.
CBS-3000	Pair of Bale Spears	3000 lbs.	135#

All Forks and Bale Spears come with sliding handle, screw and swivel locking plate. They are zinc coated for easy operation and to prevent rust.

Pallet Forks

Fork Attachments That Turn Your Tractor Loader Into A Low Cost Forklift

Brackets For Loader Pin-On & JD Quick Attach



**ULF-2242
Shown**



**ULF-3542
Shown**

These handy fork attachments turn your tractor/loader into a low cost forklift. The forks feature lockable tines and slotted rails. The solid tines are made of Boron Steel and then are heat treated. Two mounting styles are available; direct pin-on and JD quick attach.

FEATURES:

- Load capacities of 2250 & 3750 lb.
- Fits compact and utility loaders
- Forks are constructed of Boron steel and heat treated
- Adjustable and lockable rail style forks
- Equipped with high visibility load guard



WARNING: The loader mounted fork attachments are specifically designed to engage and load palletized materials. Do not use forks to handle large loads, such as bales, posts, etc., and avoid carrying loose or shiftable loads, as they can fall or roll back onto operator causing serious injury or death.

SPECIFICATIONS:

MODELS:	ULF-2242	JLF-2242	ULF-3542	ULF-3548
Lift Capacity:	2250 lbs.	2250 lbs.	3750 lbs.	3750 lbs.
Fork Length:	42"	42"	42"	48"
Tine Size:	1 1/4" x 3" Solid	1 1/4" x 3" Solid	1 3/8" x 4" Solid	1 3/8" x 4 1/2" Solid
Loader Mounts:	Fits many compact loaders that measure between 28 1/4" ID & 47 1/4" OD with 3/4" or 1" pins	Fits John Deere compact loaders with quick-change attachment carrier	Fits many loader frames between 32" ID & 48" OD with 1" or 1 1/8" pins	Fits many loader frames between 32" ID & 48" OD with 1" or 1 1/8" pins
Weight:	280#	280#	370#	385#

Available For Universal, John Deere, & Global / Euro Quick Attach



**2300 Lb.
Cap. Shown**

**3750 Lb.
Cap. Shown**



The new heavy duty frames are designed to handle both the 3750 and 5500 lb. capacity forks. The 10 gauge brickguard offers outstanding strength and smooth surface for protection and less load damage. Also, the convenient non-skid step offers easy operator access, except 2300 lb. capacity. The tine end visibility is excellent.

SPECIFICATIONS:

Code No.	Description	Capacity	Tine Length	WT.
108308	Q.A. Pallet Fork Assy	2300 lbs.	42"	250#
108309	Q.A. Pallet Fork Assy	2300 lbs.	48"	265#
17380 / 102028	Q.A. Pallet Fork Assy	3750 lbs.	42"	335#
17380 / 102030	Q.A. Pallet Fork Assy	3750 lbs.	48"	355#
101177/102028	J.D. Pallet Fork Assy	3750 lbs.	42"	410#
101177/102030	J.D. Pallet Fork Assy	3750 lbs.	48"	440#
17380 / 102032	Q.A. Pallet Fork Assy	5500 lbs.	42"	375#
17380 / 102034	Q.A. Pallet Fork Assy	5500 lbs.	48"	395#

FEATURES:

- Available in 2300, 3750 & 5500 lb. capacities
- Fork tines available in 42" & 48" length
- Exclusive load retention hook for securing and positioning pallet loads
- Solid tine positioning with spring loaded toggle operation
- Easy loading with tapered tines

Chain Harrows

Operating Positions To Produce Aggressive, Light, or Minimum Action

FEATURES

- ❑ Tines 1/2" diameter by 4 1/4" long
- ❑ No parts to lubricate or adjust
- ❑ Offset tines eliminate ridges
- ❑ Evenly works the ground regardless of terrain
- ❑ Cold formed tines eliminate breakage
- ❑ Can be operated at speeds of up to 8 MPH

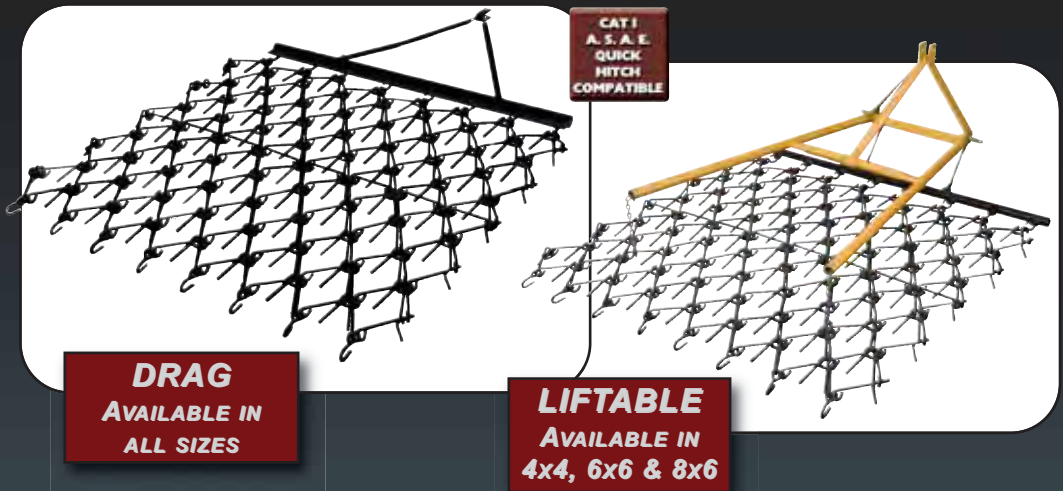

VARIABLE ACTION FOR EVERY APPLICATION



AGGRESSIVE ACTION
Tines stand up at 75° angle



LIGHT ACTION
Reversed tines angled farther back



MINIMUM ACTION
Tines in smoothing position

PASTURE RENOVATION & MAINTENANCE

Spreads and incorporates manure, thatches dead growth, aerates soil, increases moisture penetration and renovates pastures by preparing soil for seeding while stimulating existing growth.

DIRT & GRAVEL MAINTENANCE

For ball diamonds, race tracks, dirt and gravel roads, rodeo arenas, etc. Smooths rough spots, fills holes and incorporates moisture.

GRASS & TURF MAINTENANCE

For parks, golf courses and playing fields. Incorporates seed, dethatch turf and aerates soil. Pulls out dead material without disturbing new growth.

ALL TILLAGE APPLICATIONS

Prepares firm, level seedbed in combination with drills, cultivators and discs. Can be used to break up crusts and clods. Incorporates herbicides evenly because flexible design assures uniform depth.

5/8" Tines Drag Chain Harrows



Flexible Two-Way design for Optimum Debris Clearance

Pull backwards for light penetration Pull forward for deep penetration



FEATURES:

- ❑ 2" Pipe drawbars with 5/8" chain
- ❑ Tines 5/8" diameter x 6" long
- ❑ Cold formed tines eliminate breakage
- ❑ Evenly works the ground regardless of terrain
- ❑ No parts to lubricate or adjust
- ❑ Can be operated at speeds up to 8 M.P.H.

CHAIN SECTIONS				DRAWBARS ONLY		
MODEL #	WIDTH	DEPTH	WT.	MODEL #	WIDTH	WT.
H4X4	4'	4'	70#	D4	4'	16#
H5X4	5'	4'	86#	D5	5'	18#
H6X4	6'	4'	105#	D6	6'	22#
H6X6	6'	6'	157#	D8	8'	27#
H6X8	6'	8'	209#	D10	10'	60#
H8X6	8'	6'	209#	D12	12'	70#
H10X4	10'	4'	174#	D1D	Adaptor Kit	

MODEL NO.	TYPE	DESCRIPTION	WT.
D4-4x6-5/8	Drag	4' Wide x 6' Deep	150#
D6-6x8-5/8	Drag	6' Wide x 8' Deep	310#
G6-3P-6x6-5/8	3-Point	6' Wide x 6' Deep	280#
D8-8x8-5/8	Drag	8' Wide x 8' Deep, 2 - 4' x 8' Sect.	373#
G8-3P-8x6-5/8	3-Point	8' Wide x 6' Deep, 2 - 4' x 6' Sect.	351#
D10-10x8-5/8	Drag	10' Wide x 8' Deep, 2 - 10' x 4' Sect.	490#
D12-12x8-5/8	Drag	12' Wide x 8' Deep, 2 - 6' x 8' Sect.	634#

Arena Rotary Harrows & Drag Mats



GRH6B w/optional drag mat shown

CAT I
A. S. A. E.
QUICK
HITCH
COMPATIBLE



Now with replaceable teeth

The GRH Series of **Rotary Harrows** were designed to aerate soil and pull weeds. The unique turning action allows the harrow to level soil by redistributing it inward. Excellent tool for moving high spots away from fences and walls. Levels, floats and breaks up clods. The ideal product to use in arenas.

FEATURES:

- ❑ Cat. I, 3-point hitch
- ❑ 2" x 2" Square tubing wheel with 5 spokes
- ❑ 5 1/2" High carbon teeth
- ❑ Sealed bearing hub
- ❑ Heavy 3" x 4" tubing frame

SPECIFICATIONS:

MODEL NUMBER	DESCRIPTION	WEIGHT
GRH4E	Rotary Harrow, 4 Foot	155#
GRH5E	Rotary Harrow, 5 Foot	170#
GRH5B	Rotary Harrow, 5 Foot	240#
GRH6B	Rotary Harrow, 6 Foot	290#
GRH7B	Rotary Harrow, 7 Foot	335#
GRH8B	Rotary Harrow, 8 Foot	385#



GRH5E Shown

The heavy duty **Drag Mats** finish the soil to a fine smooth surface. The mat also catches and drags out clods and small rocks. The units are galvanized to prevent rust and are long wearing. The carrier frame is easy to install on current and existing Rotary Harrows.

These compact **Arena Rotary Harrows** were especially designed for compact tractors from 15 to 24 horsepower.

FEATURES:

- ❑ Available for GRHB rotary harrows only
- ❑ Adjustable bolt-on carrier frame
- ❑ Rust resistant galvanized steel mats
- ❑ 1" x 1" Mesh openings and full length rods
- ❑ 3 Times the strength of standard mats

SPECIFICATIONS:

MODEL NO.	DESCRIPTION	WEIGHT
AH-DMC	Carrier, fits all mats widths	35#
DM-6	Drag Mat, 6' x 30" deep	65#
DM-8	Drag Mat, 8' x 30" deep	95#

For Tractors 24 PTO Horsepower Maximum

These 6 implements allow compact tractors to perform many different tasks. The tractor 3-point hitch makes it easy to change these tools. Whether you want to grade, disc, mow, rake, or subsoil, these economy implements will do those jobs with minimal effort.



**RAKE 60"
TYR-60-XB**

- ❑ Heavy duty heat treated spring steel shanks
- ❑ 5 Forward and 5 reverse settings
- ❑ Reinforced square tubing frame
- ❑ Adjustable stabilizer bar



**BOX SCRAPER 48"
BB-48-XB**

- ❑ Front and rear reversible heat treated cutting edges
- ❑ Adjustable heat treated shanks
- ❑ 12" High self cleaning moldboard
- ❑ 2" x 4" Main beam



**REAR BLADE 60"
TRB-60-XB**

- ❑ 10" High 1/4" thick moldboard
- ❑ 5 Forward and 5 reverse settings
- ❑ Reinforced square tubing frame
- ❑ Reversible high carbon cutting edge



**FINISHING MOWER
48" FM-48-XB**

- ❑ Dual wheels front and rear
- ❑ Free floating flex hitch system
- ❑ 3 Cast iron spindles and 1/4" thick blades
- ❑ Front anti-scalp roller



**TANDEM DISC 60"
14-16-N-XB**

- ❑ Heavy angle iron frame
- ❑ Cast iron bearing spools w/grease fittings
- ❑ Adjustable angle settings
- ❑ 1" Square axles and 14" high carbon blades



**MIDDLE BUSTER/
SUBSOILER MB-S-XB**

- ❑ Steel tubing shank
- ❑ Heavy steel frame
- ❑ Heat treated, furrower and subsoiler point
- ❑ Forged lift pins

We offer a wide variety of construction attachments manufactured by Bradco.

Skid Hoes



**Swing Boom
Hoe Shown**

FEATURES:

- ❑ Skid Steer quick attach mount in fixed or swing boom
- ❑ Electric over hydraulic controls
- ❑ Swing cylinder provides 140° rotation - allows placement of spoil outside tracks of 72" skid steer
- ❑ Bucket digging force - 3800 lbs. Max. reach - 6' 4"
- ❑ Bucket sizes of 12", 16", 18", & 24"
- ❑ Req's 6 GPM, 12 Volt power source, & 30 HP

4-In-1 Buckets



**Construction Series
shown with optional side
cutter and spill guard**

FEATURES:

- ❑ 3 Series in widths of 60", 66", 72", 78", & 84"
- ❑ For machine weights of 4,000, 8,000 and 12,000#
- ❑ Long floor design improves cutting edge visibility
- ❑ "Hose Saver" spring kit standard, except on compact units
- ❑ Unique side cutters on construction series only
- ❑ Effective loader bucket for clam, dozer, scraper and bottom dump operations

Sifting / Rock Buckets

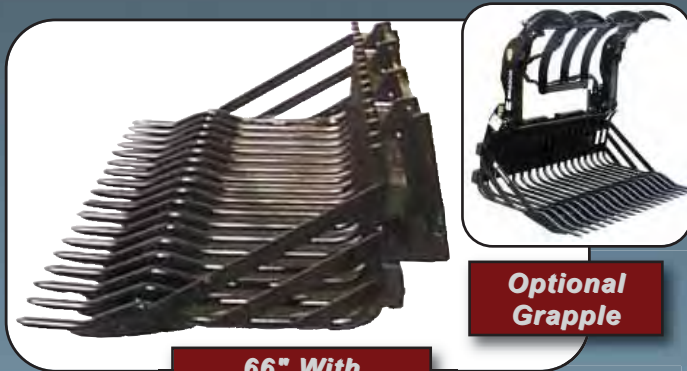

**66" With
Loader Arms**

**Optional
Grapple**

FEATURES:

- ❑ Widths of 55", 66", 75" and 84"
- ❑ Brackets to fit loader arms, Skid Steer and quick attach
- ❑ Unique tine design is contoured to cradle the debris and rocks
- ❑ Rods are 1 1/4" diameter high alloy steel
- ❑ Standard buckets come with 3 1/8" spacing between tines, with the option of 2" spacing
- ❑ 55" Bucket has 3/4" diameter rods

Trenchers



**Model #612 For
Tractors 22 - 35 HP**

**Model #330 For
Tractors 15 - 30 HP**

FEATURES:

- ❑ 3 Pt. hitch, PTO driven for 15 to 35 HP hydrostatic transmission tractors
- ❑ Digging depths from 30" to 60" deep
- ❑ Digging widths from 3" to 12" wide
- ❑ Large discharge auger places soil away from trench
- ❑ Built with the best of heavy duty components

Manufactured by:



PALADIN LIGHT CONSTRUCTION

Time and Labor Saving Implements**PLOWS**

These Moldboard Plows are ideal for small acreage farms when deep tillage is required.

FEATURES:

- Cat. 1, 3-point hitch
- Available in 1 or 2 - 14" bottoms
- 1" x 4" Plow beams
- Replaceable plow share, shins and landsides

CULTIVATORS

Our "S" tine cultivators are available in widths of 4 to 10 feet. The tine springs vibrate to aid in breaking up the soil.

FEATURES:

- Heavy duty "S" tines penetrate & till up to 7" deep
- "S" tines are heavy duty $\frac{3}{8}$ " x $1\frac{1}{4}$ " x 22" spring steel
- Available with $1\frac{3}{8}$ " reversible points or 7" sweeps

RIPPER BARS

These Ripper Bars are excellent for aerating pastures and other ripping applications.

FEATURES:

- Cat. I, 3-point hitch
- 5, 6, and 7 Shank sizes
- Rips up to 8" deep
- Shear bolt protection

ALL-PURPOSE MIXERS

Our economy mixer effectively blends materials including concrete, feed, and fertilizers.

FEATURES:

- Cat. I, 540 RPM P.T.O.
- Capacity - 11 cu. ft.
- Mixes $1\frac{1}{2}$ sacks of cement
- Single acting cylinder with hose

Time and Labor Saving Implements

ARENA-VATOR JR.



Unique tool for cultivating and to finish smooth out your arena. The tilling depth is controlled by an electro cylinder operated from the vehicle seat.

FEATURES:

- ❑ 5' Cultivating width
- ❑ 13 - 5/16" x 1" x 15" "S" Tines w/points
- ❑ Adjustable smoothing box
- ❑ Model # AV-JR

SPINNER SPREADER



"NEW"

This spreader features a 12 volt motor with variable speed control and on/off switch. The molded poly hopper has the capacity of 145 pounds. Includes brackets to mount on all types of vehicles.

FEATURES:

- ❑ Model ATV-DMS-12V can spread fertilizer, seeds, and powders
- ❑ Adjustable spread widths of 5 to 45 feet
- ❑ Stainless steel six blade spinner
- ❑ Optional 1 1/4" or 2" hitch receiver

WHEEL DISC



The wheel design is engineered for smooth transition from off-road transport to cutting position with just the turn of a crank. The turnbuckle mounted tongue to frame gives down pressure to increase cutting action.

FEATURES:

- ❑ 33" Cutting width
- ❑ 10 - 14" Diameter notched blades
- ❑ Dual floatation tires
- ❑ Model # 14-10-CD

ROLLER, PULL



**ROLLER
3-PT.**

These rollers are available in 3-point or pull type in many different widths. For more compaction, adding water will greatly increase the rolling force.

FEATURES:

- ❑ Available in widths of 60", 72", 84", and 96"
- ❑ Roller diameter of 16" and 20"
- ❑ 1/4" Thick roller tubing
- ❑ 1 7/16" Full length shaft

Many Implements Are Available For Quick Attach or Loader Pin-on

BRACKETS AND IMPLEMENTS FOR COMPACT TRACTOR LOADERS

The **Quick Attach** bracket for compact tractors allows you to change loader attachments in minutes. Just unlatch the quick attach, back out of one implement and drive into another, flip the locking handles and you are ready to go back to work.

FEATURES QUICK ATTACH BRACKET:

- ❑ The Quick Attach mounts directly to your loader arm and cylinders in minutes
- ❑ No special pins or modification to the loader are necessary
- ❑ Available for most popular compact tractor loaders
- ❑ A weld-on conversion plate converts the original bucket to accommodate the Quick Attach
- ❑ Available for most popular tractors
- ❑ Allows for mounting of popular skid-steer loader implements



**Root rakes available in widths of 60", 66", & 72"
Available in quick attach only**



Standard, light material and heavy duty buckets in widths of 60", 66", and 72"



Multi-purpose 4 in 1 buckets in widths of 60" & 66". Also HD buckets - 66", 72", & 78"

For other quick attach or pin-on loader implements, see the index.

Grapple & Electro Hydraulic Kits

Turns Your Standard Bucket Into a Versatile Grapple Bucket



FEATURES:

- ❑ Grapples allow you to pick up material impossible to do with plain loader buckets, such as; brush, loose hay, leaves, bales, manure, etc.
- ❑ Available in single or double grapple
- ❑ Fits 48 to 84 inch wide compact tractor loader buckets
- ❑ Hydraulic cylinder gives a strong, tight grip to the material you are moving
- ❑ Full length torque tube made of 2 1/2" schedule 40 pipe
- ❑ Available in single or double grapple
- ❑ Greaseable 1" hinge pins
- ❑ 3 - Large 3/8" thick grapple hooks on each grapple
- ❑ 1 3/4" x 6" Hydraulic cylinder (Hydraulic hoses and hardware is included)

SPECIFICATIONS:

MODEL NO.	DESCRIPTION	BUCKET WIDTH	WEIGHT
GK-4866	Single Grapple Kit	48" to 72"	140#
GK-6078	Double Grapple Kit	60" to 84"	250#

Allows Operating Loader Mounted Hydraulic Implements

Gearmore Electro Hydraulic Components were developed to obtain a simple, compact way to operate loader mounted hydraulic implements. The mounted electro hydraulic valve is easily operated by a push button switch knob mounted on the tractor loader valve lever. This allows operation of the loader functions and hydraulic implements without moving your hand.

FEATURES:

- ❑ Electro hydraulic valve, operates hydraulic functions up to 13.2 G.P.M.
- ❑ Easily installed replacement loader knob with push button electric switch
- ❑ Valve mounting bracket and hardware

Model # EH-100

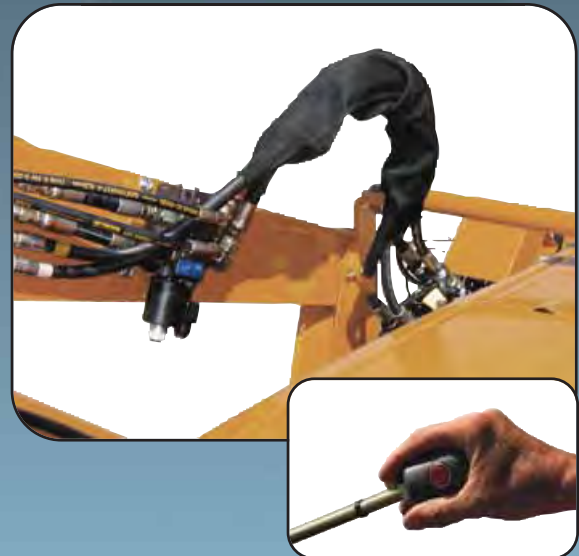

SPECIFICATIONS:

MODEL NO.	DESCRIPTION	WEIGHT
*EH-100	Electro Hydraulic Valve Components for dealer installation on tractor loader	10#

* Dealer to supply hoses, fittings, and wiring

Log Splitters

All Models Can Be Operated in the Vertical or Horizontal Positions



**Trailer Models -
34 Ton
Capacity**



**Trailer Models -
22 Ton
Capacity**

**3-Point Hitch
Model - 15 Ton
Capacity**

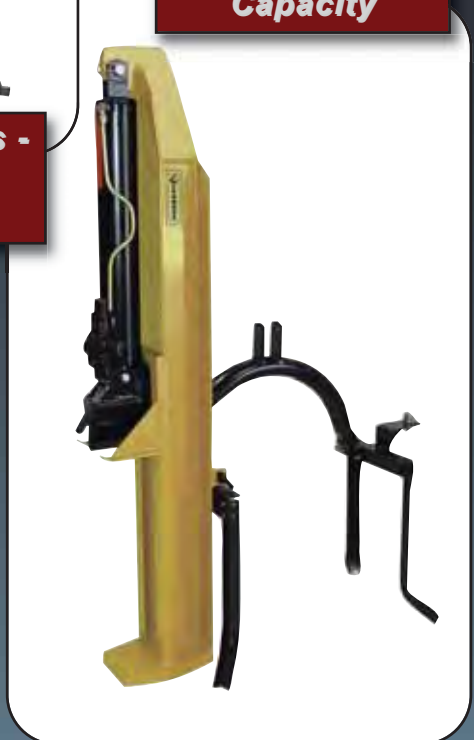

Our complete line of Log Splitters are available in 3-point hitch and trailer mounted. Splitting capacities of 15 to 34 ton, depending on your requirements. All models feature automatic cylinder return for convenience. The built-in log cradle makes splitting wood easier and safer. These top of the line splitters will give you years of trouble free usage.

SPECIFICATIONS:

MODEL NUMBER:	LS20E	T22B	T22H	T34B
Capacity:	15 Ton	22 Ton	22 Ton	34 Ton
Mount:	Cat. I	Trailer	Trailer	Trailer
Cylinder Size:	4" x 24"	4" x 24"	4" x 24"	5" x 24"
Power:	Hydraulic	6 H.P. B/S	5.5 H.P. Honda	10.5 H.P. B/S
Pump:	Tractor	2 Stage 11 GPM	2 Stage 11 GPM	2 Stage 16 GPM
Beam Size:	4 1/2" x 7"	6" x 6"	6" x 6"	8" x 10"
Splitting Wedge:	7"	7"	7"	8"
Maximum Log Length:	26"	26"	26"	26"
Weight:	375#	430#	430#	675#

All trailer mount log splitters come with 4:80 x 8" tires, 2" ball hitches, safety chains, and jackstands

Flail Mowers

Featuring "No Tools" Blade Changing System

"SLE" Series



QUICK CHANGE Y BLADE

QUICK CHANGE DUCKSFOOT BLADE

This Gearmore mower series was developed for mowing weeds and light brush with side slicing Y blades. All models are also available with finish mowing cupped "ducksfoot" blades for mowing grass. Standard features include ASAE quick attach 3-point hitch, low profile design, center mount or offset, adjustable rear roller and many more.

These flail mowers were designed to achieve fine shredding on cover crops, parks, golf courses, pastures, and light weed abatement.

FEATURES:

- Cat. I, A.S.A.E. quick hitch compatible for easy attaching to tractor
- Designed for tractors that have 540 rpm PTO speed
- Low profile design for clearing obstructions
- Available with side slicing Y blades for light brush or grass finishing
- Ducksfoot blades
- Center mount or offset 9 inches to right
- Pivoting 3-point hitch back brace for added strength and to easily offset hitch
- 45 Horsepower, 540 rpm gearbox
- Rotor speed - 2340 rpm with blade tip speed of 8267 feet per minute
- 3 Belt final drive with automatic belt tightening idler to provide maximum power to the blades
- Internal "saw tooth" cutter bar to reduce the size of the shredded material
- 5" Diameter rear roller
- Two adjustable parking stands to allow easy "hook-up" to quick hitch tractor
- Safety chain shield in front and rubber rear deflector

SPECIFICATIONS:

MODEL NO.	MOWING WIDTH	OVERALL WIDTH	NO. OF KNIVES	MIN. H.P. REQUIRED	WEIGHT
SLE-120	48"	54"	22	20	415#
SLE-160	63"	69"	30	28	525#
SLE-190	75"	81"	36	35	620#

"GML" Series

The **Gearmore Flails** are the ultimate in flail mowers. The mowers are heavy built with 40 H.P. gearbox, to give years of trouble free service. Two types of blades are available - hammer and Y blades, both do clean cutting on light brush and grass. High speed 2300 R.P.M. rotor makes for smooth finished cut. The adjustable rear roller ensures even mowing.

These flail mowers are just right for use in mowing cover crops, parks, schools, golf courses, pastures, roadsides, etc.

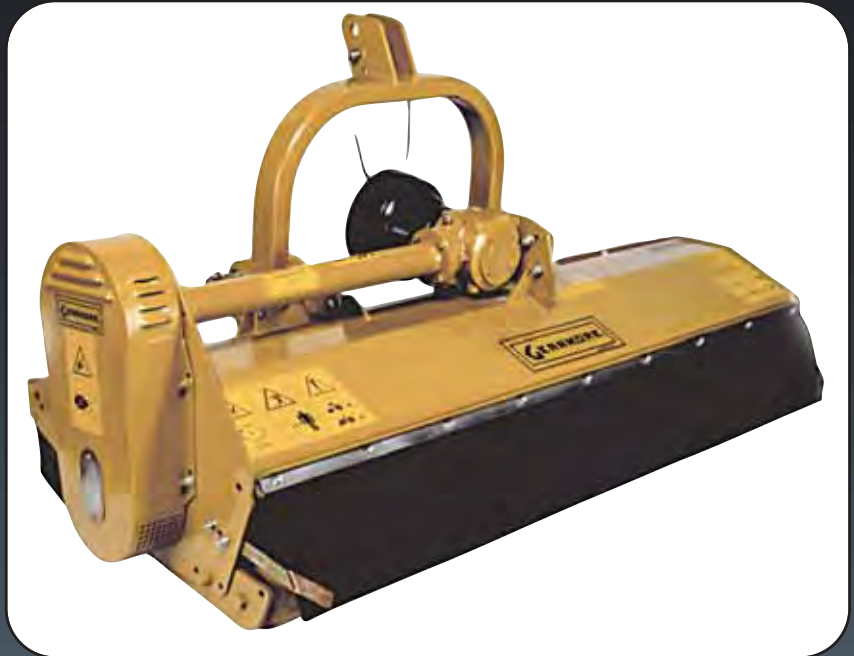

FEATURES:

- Fits Cat. I, 3-pt. hitches, 540 R.P.M. tractors
- Mows grass and weeds up to 1/2" with Y blades
- Shreds brush up to 1 1/2" diameter with swinging hammer blades
- Cutting height adjusts from 3/4" to 3"
- Heavy duty 40 H.P. gearbox
- Hood is 8 gauge steel, double plated front and back for added strength
- Computer balanced vibration free rotor turns at 2300 R.P.M.
- Rotor diameter 4 1/2"
- Gearbox set back to allow use of longer driveshaft to reduce wear and increase life
- 3 Belt drive protects gearbox, driveshaft and rotorshaft



Hammer Knife
Up to 1 1/2" Brush

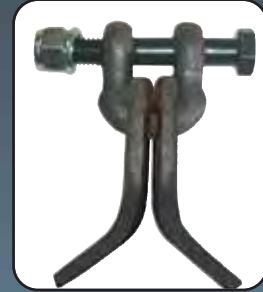

Y Blade
Up to 1/2" Brush

- Front metal flaps provide safety from flying material
- Rear rubber safety flaps
- Rotor tubing thickness 41" to 61" - 1/4" 69" to 79" - 13/32"

SPECIFICATIONS:

MODEL NO.	MOWING WIDTH	OVERALL WIDTH	NO. OF HANGERS	MIN. H.P. REQUIRED	WEIGHT
GML-41	41"	46"	18	16 H.P.	495#
GML-49	49"	53"	24	20 H.P.	580#
GML-61	61"	66"	27	24 H.P.	670#
GML-69	69"	73"	33	28 H.P.	740#
GML-79	79"	84"	39	35 H.P.	855#

Flail Mowers

Center Mount, Offset Mechanical or Hydraulic

"SFG" Series



CAT I
A. S. A. E.
QUICK
HITCH
COMPATIBLE

Model SFG155 w/Optional Rake Teeth & Roller Scraper

Our new SFG Series of flail mower/shredders feature fixed center mount, manual or hydraulic side shift. The narrow shredders are fixed center mount. The two largest shredders are manual offset, return to center with optional hydraulic offset. Two style of blades can be purchased, hammer knives or double Y blades. These blades are also interchangeable on the same shredders. The low profile design of the machine aids when working in tight areas. These are popular mowers in vineyards, berries, roadsides, weed abatement, rental yards, etc.

FEATURES:

- Cat. I ASAE quick hitch, 540 RPM tractors
- Fixed center mount hitch, except SFG185/200
- 70 HP gearbox with built-in overrunning clutch
- Low profile belt housing, 23" high for clearance
- Hammer knives shreds brush & prunings up to 2" dia.
- Double Y Blades mow weeds & light brush up to 1" dia.
- Cutting height adjusts from 1" to 4" above ground
- Rotor speed - 2200 RPM
- Two rows of heat treated re-cutter blades
- Rear hatch adjusts for various types of mowing
- Rear hatch slotted for rake teeth
- Balanced 5 1/2" rotor tubing
- 5 1/2" Diameter rear roller adjusts vertically and horizontally
- Models SFG95 & 125 are *not* quick hitch
- 4 Belt final drive with automatic spring tension idler to provide maximum power to the rotor
- Series 6 PTO driveshaft
- Front mounted safety chains
- Rear rubber deflector

OPTION: Rake Teeth



HAMMER KNIFE

DOUBLE Y BLADE

SPECIFICATIONS:

MODEL NO.	WORKING WIDTH	OVERALL WIDTH	MAX. OFFSET*	NO. OF HAMMERS	NO. OF Y BLADES	H.P. REQ'D	RAKE SLOTS	WT.
SFG95	38"	43"	-	8	32	20	6	620#
SFG125	49"	55"	-	8	32	25	8	730#
SFG140	55"	61"	-	10	40	30	9	770#
SFG155	61"	67"	-	10	40	35	10	840#
SFG185*	73"	78"	44"	12	48	40	12	1005#
SFG200*	79"	84"	48"	14	56	45	13	1100#

* These shredders come with manual offset, hydraulic offset is optional. Offset shown is the maximum offset from centerline of tractor to the right

"GCF" Series

Our new "GCF" Series Mower/Shredders are now designed for front or rear tractor mount. To front mount, just re-bolt the A-frame to the back of the shredder. The added versatility of hammer knife for brush mowing and Y blades for grass mowing makes these mower/shredders the most popular units we have available.

Just right for use in vineyards, berries, and other narrow row crops. Also used by roadsides, parks, rental yards, and general weed abatement.



FEATURES:

- ❑ Fits Cat. I & II, 3-pt. hitches, 540 R.P.M. tractors
- ❑ Front or rear tractor mount
- ❑ HD 72 H.P. gearbox with built-in overrunning clutch
- ❑ Hammer knives shred brush and prunings up to 2", and will also mow grass
- ❑ Y blades mow heavy grasses & light brush up to 1 1/2" and require less horsepower
- ❑ Cutting height adjusts from 1" to 4"
- ❑ Specially designed drop forged hammer or Y blades
- ❑ Drop forged cutter bar to increase the shredding of material
- ❑ Computer balanced vibration free rotor turns at 2000 R.P.M.
- ❑ Adjustable A-frame allows offsetting of mower 6" to the right
- ❑ Front safety chains provide safety from flying material
- ❑ Equipped with a rear deflector which in open position discharges grass and allows tractor speeds up to 6 MPH, and in closed position contains and further shreds brush to a finer mulch



**Hammer Knife Shreds
Up to 2" Brush**



**Y Blade Shreds
Up to 1 1/2" Brush**



**Units Available With
Brush Teeth**

SPECIFICATIONS:

MODEL NO.	MOWING WIDTH	OVERALL WIDTH	NO. OF KNIVES	MIN. H.P. REQ'D	WEIGHT
GCF41	41"	46"	9	20 HP	615#
GCF45	45"	50"	12	25 HP	630#
GCF53	53"	58"	12	30 HP	725#
GCF61	61"	66"	15	35 HP	835#
GCF69	69"	74"	18	40 HP	935#
GCF79	79"	84"	21	45 HP	1070#

Flail Mowers

Available With Rear Roller or Dual Wheels
When Operating in Extreme Field Conditions

"GRF" Series

The Gearmore Mower/Shredders are the ultimate in flail mowing. The 3 lb. drop forged hammer knives will shred up to 3" diameter branches and yet will mow grass.

Just right for use in vineyards, orchards, roadsides, parks, pastures and weed abatement. You will find that these heavy duty machines will give many years of low maintenance usage.



HAMMER KNIFE



Also available with dual swivel gauge wheels with 15" diameter laminated tires. Add GW to Model No.

FEATURES:

- Available in Cat. I or II, 540 or 1000 R.P.M.
- Reversible front or rear center mount
- Shreds brush or prunings up to 3", constant use 2 1/2"
- Cutting height adjusts from 1" to 4"
- Specially designed drop forged hammer knives

- Equipped with an adjustable rear deflector
- Double row of drop forged cutter bars to increase the shredding of material
- Computer balanced vibration free rotor turns at 2000 R.P.M.
- Rotor bearings are double self-aligning to insure long life
- Heavy duty 85 H.P. gearbox with built-in overrunning clutch
- Belt drive protects gearbox, driveshaft and rotorshaft
- Front mounted safety chains provide safety from flying material
- 6" Diameter full width gauge roller with external bearings

SPECIFICATIONS:

MODEL NO.	MOWING WIDTH	OVERALL WIDTH	NO. OF KNIVES	MIN. H.P. REQ'D	WEIGHT
GRF69	69"	78"	18	36 HP	1265#
GRF79	79"	88"	21	45 HP	1440#
GRF89	89"	98"	24	50 HP	1605#
GRF98	98"	108"	24	58 HP	1785#

"GOL" Series

This shredder features a unique side shift system that moves horizontally on front and rear mounted heavy steel tubes. The feature allows for close coupling to the tractor for added strength and stability.

Available with hammer knives and Y blades, depending on your requirements. The "low profile" belt housing and gearbox is a great advantage when operating in orchards and vineyards.

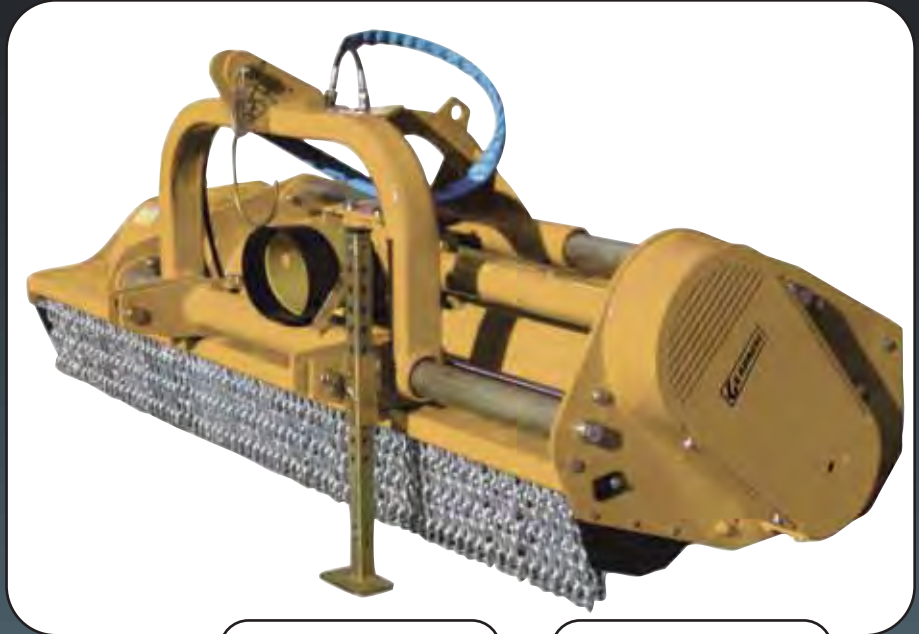

HAMMER KNIFE



Y BLADE

FEATURES:

- Cat. II, 3-point hitch
- Hydraulically offsets 22" to the right
- Low profile belt housing and gearbox
- 90 HP gearbox with built-in overrunning clutch
- Shreds brush up to 4" diameter with hammer knives and up to 1 1/2" diameter with Y blades
- Close coupled to tractor for added stability
- 5 Belt final drive
- Three rows of drop forged cutter bars to increase the shredding of material
- Adjustable rear hatch - closed for maximum shredding, open for maximum forward travel
- Double wall hood of 1/4" thick plate
- Rotor bearings are double self-aligning
- Heavy steel belt cover with hinged door
- Front mounted safety chains and rear mounted rubber guards

SPECIFICATIONS:

MODEL NO.	MOWING WIDTH	OVERALL WIDTH	MAX. OFFSET TO RIGHT OF CENTER LINE	NO. OF KNIVES	MIN. H.P. REQUIRED	WT.
GOL79	79"	89"	60"	21	55	1700#
GOL89	89"	99"	70"	24	65	1900#

"GOF" Series

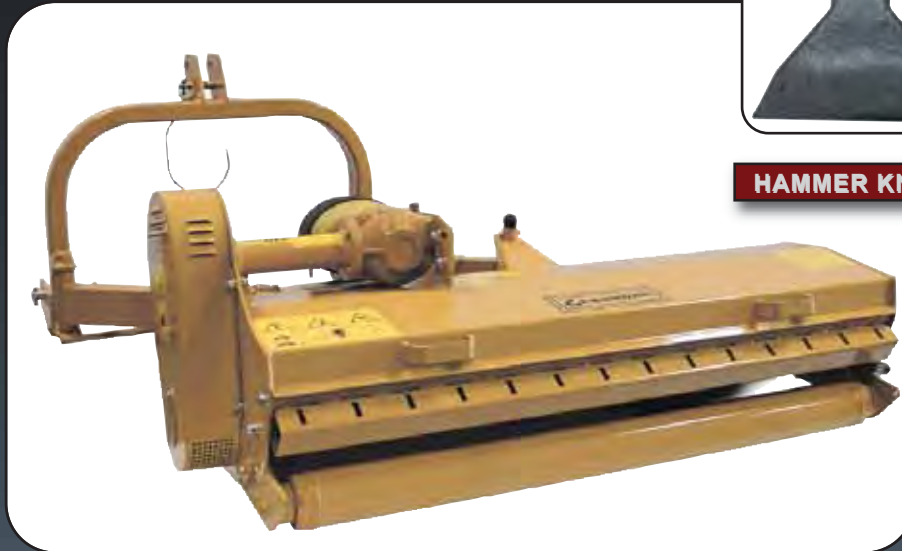

HAMMER KNIFE

The Gearmore Mower/Shredders are the ultimate in flail mowing. The 3 lb. drop forged hammer knives will shred up to 3" diameter branches and yet will mow grass.

In offset position, the units are ideal for mulching prunings and heavy grass in orchards. Municipalities find these shredders excellent for roadside maintenance.

FEATURES:

- ❑ Fits Cat. I or II, 3-pt. hitch, 540 R.P.M. tractors
- ❑ Shreds brush or prunings up to 3", constant use 2 1/2"
- ❑ Cutting height adjusts from 1" to 4"
- ❑ Adjustable swing hitch allows quick setting for an additional 28" of offset
- ❑ Specially designed drop forged hammer knives give optimum performance in brush shredding, mulching prunings, grass cutting and maintenance of cover crops
- ❑ Double row of drop forged cutter bars to increase the shredding of material
- ❑ Computer balanced vibration free rotor turns at 2000 R.P.M.
- ❑ Rotor bearings are double self-aligning to insure long life
- ❑ Equipped with a patented rear deflector which in open position discharges grass and allows tractor speeds up to 6 MPH, and in closed position contains and further shreds brush to a finer mulch
- ❑ Heavy duty 85 H.P. gearbox with built-in overrunning clutch
- ❑ Gearbox set back to allow use of longer driveshaft to reduce wear and increase life
- ❑ 5 Belt drive protects gearbox, driveshaft and rotorshaft, 4 belt on model GOF69-79
- ❑ Front mounted safety chains provide protection from flying material
- ❑ 6" Diameter full width gauge roller with external bearings
- ❑ All models have slotted rear hatches to accept brush teeth

SPECIFICATIONS:

MODEL NO.	MOWING WIDTH	OVERALL WIDTH	NO. OF KNIVES	MAX. OFFSET FROM CENTERLINE OF TRACTOR	MIN. H.P. REQUIRED	WT.
GOF69	69"	78"	18	64"	40 HP	1205#
GOF79	79"	88"	21	74"	45 HP	1305#
GOF89	89"	98"	24	84"	50 HP	1405#
GOF98	98"	108"	24	93"	57 HP	1535#
GOF108	108"	118"	27	103"	65 HP	1655#

"GHF" Series

This **Shredder** is specially designed for severe conditions. Tall grass and weeds, cover crops, orchard prunings and even citrus brush are no match for this heavy duty machine. The 3 lb. drop forged hammer knives shred branches up to 4" in diameter. The 2000 R.P.M. large diameter rotor, makes a fine mulch. Easy to switch hitch allows the shredder to be mounted on the rear or front of tractors.



HAMMER KNIFE

FEATURES:

- ❑ Cat. II, 3-pt. hitch, center mount
- ❑ Front or rear tractor mount
- ❑ Shreds brush or prunings up to 3", intermittent 4"
- ❑ Gearbox HP at 540 R.P.M.-90 HP, 1000 R.P.M.-110 HP with built-in overrunning clutch
- ❑ Specially designed drop forged hammer knives give optimum performance in brush shredding, mulching prunings, grass cutting and maintenance of cover crops
- ❑ Equipped with a patented rear deflector which in open position discharges grass and allows tractor speeds up to 6 MPH, and in closed position contains and further shreds brush to a finer mulch
- ❑ Double row of drop forged cutter bars to increase the shredding of material
- ❑ 10" Diameter, computer balanced, vibration free rotor turns at 2000 R.P.M.
- ❑ Rotor bearings are double self-aligning to insure long life
- ❑ 5 Belt drive protects gearbox, driveshaft and rotorshaft
- ❑ 8" Diameter, full width gauge roller
- ❑ Hood plate 1/4" thick, double plated front and back side plates 1/2" thick
- ❑ Double row of front safety chains
- ❑ Rubber rear guard

SPECIFICATIONS:

MODEL NO.	MOWING WIDTH	OVERALL WIDTH	NO. OF KNIVES	MIN. H.P. REQUIRED	WEIGHT
GHF90	90"	100"	24	50 HP	2000#
GHF100	100"	112"	26	58 HP	2200#
GHF140	140"	152"	36	78 HP	3080#

Maxi Shredders

For Front or Rear Mount 3-Point Tractors

"GMS" Series



This **Shredder** is specially designed for shredding standing trees and tall shrubs or for down material. The brush frame, as shown, is used when driving into standing material. When driving over loose, down material, a rear roller is used in place of the brush frame and skids. The **Maxi Shredder** has a 1000 R.P.M., 110 HP gearbox. It can be front or rear mounted. The reversible, drop forged, hammer knives will shred trees up to 8" in diameter.

The shredder is ideal for clearing utility right ways, reduction of wood waste in landfills, land clearing, fire lanes and many agricultural tree and plant residue shredding applications.



**REVERSIBLE
HAMMER KNIVES**

FEATURES:

- Cat. II, 3-point hitch, center mount
- Front or rear tractor mount
- Shreds brush and trees up to 8"
- Gearbox HP at 1000 R.P.M., 110 HP with built-in overrunning clutch
- Specially designed drop forged, reversible hammer knives
- Hydraulically operated deflector hood
- 16" Diameter, computer balanced, vibration free rotor turns at 2000 R.P.M.
- Rotor shaft bearings are double self-aligning to insure long life
- 5 Belt drive protects gearbox, driveshaft and rotor shaft
- Double row of safety chain
- Brush frame and adjustable skids for standing brush or a rear roller for operating in low or down material

SPECIFICATIONS:

MODEL NO.	MOWING WIDTH	OVERALL WIDTH	NO. OF KNIVES	APPROX. H.P. REQUIRED	WEIGHT
GMS70	70"	81"	29	60 HP	2420#
GMS80	80"	91"	33	70 HP	2590#
GMS90	90"	101"	38	80 HP	2850#

Rotary Mowers

Available in Widths of 48" & 60" with Briggs & Stratton 13 or 17.5 HP Engines

Engine Driven



Our Rotary Mowers are designed with a special safety remote, electrical stop feature. The system has dual action engine stopping controls: a manual stop switch if you run into obstructions in the mowing area, and an automatic stop system by placing the controls between your hip and the vehicle seat. This feature automatically stops the engine for the unlikely event that you fall from the vehicle.

FEATURES:

- Briggs & Stratton industrial/commercial OHV engines
- 12 Volt electric start
- 48" & 60" Cutting widths
- Dual action remote control electrical engine/blade stop safety system
- Center mount and easy to offset - right or left
- Two 1/4" x 2 1/2" swing brush blades
- Single point height adjustment 1" to 5"
- Large 16 x 6.50 x 8 pneumatic tires
- 1/8" Steel plate deck
- Rubber front & rear safety guards
- Cuts weeds and brush up to 1/2" - 3/4" diameter
- Chrome plated, diamond plate steel rear safety deck
- Centrifugal clutch for slip protection

Models ERM-416 & 617 have separate poly fuel tank
NOTE: Mowers sold less battery

SPECIFICATIONS:

MODEL NO.	CUTTING WIDTH	ENGINE H.P.	OVERALL WIDTH	HITCH OFFSET	WT.
ERM-413	48"	13 H.P.	55 1/2" - 68"	Up to 24"	485#
ERM-416	48"	17.5 H.P.	55 1/2" - 68"	Up to 24"	500#
ERM-617	60"	17.5 H.P.	67 1/2" - 80"	Up to 30"	600#

Finishing Mowers

FEATURES:

- Free floating, flex hitch system
- Heavy duty steel deck, with rear discharge
- Heavy duty cast iron gearbox
- Easy height adjustment
- Turf friendly, 9 x 3.50 - 4 ply solid rubber tires
- Anti-scalp front roller
- Fully baffled deck

SPECIFICATIONS:

MODEL NO.	CUTTING WIDTH	BLADE SIZE	BLADE TIP SPEED - FPM	WT.
RFM-48	48"	1/4" x 2" x 16"	14,400	620#
RFM-60	60"	1/4" x 2" x 20"	17,985	660#
RFM-72	72"	1/4" x 2" x 24"	18,463	710#
RSFM-72*	72"	1/4" x 2" x 24"	18,463	720#

*Special belt with double V design helps to prevent slippage in rough mowing conditions



We now have available rear discharge mowers featuring totally open rear deck with belt guards that allow the grass to be safely and smoothly discharged giving your turf that rich, manicured look. Some of the other outstanding features are: Free floating flex hitch, dual tires front and rear, self-tightening belt, 40 H.P. gearbox, and heavy duty fully baffled steel deck.

Rotary Mowers

Dual Gauge Wheels For Stability
on Compact Tractors

48" & 60" Width Mowers

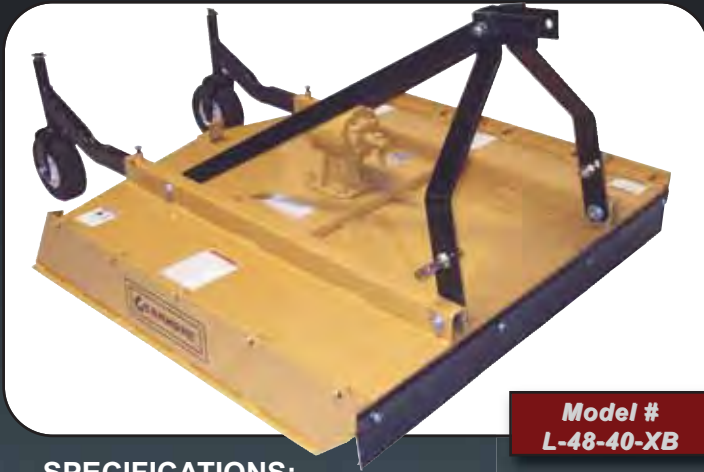

Model #
L-48-40-XB

SPECIFICATIONS:

Model No.	Cutting Width	Overall Width	Overall Depth	Weight
L-48-40-XB	48"	51"	62"	400#
L-60-40-XB	60"	63"	74"	450#



200 Series Std. Duty

Our **200 Series Mowers** feature round back design for easy maneuvering in tight corners, around trees, fences, and other obstructions. The rounded rear opening also allows for more even distribution of exiting material. All models now feature higher horsepower gearboxes, which allow for operating safely with higher horsepower tractors. The flexible floating hitch follows the contour of the terrain without putting stress on the mower and tractor. Also, hitch is designed to A.S.A.E. quick hitch standards for easy hook-up to tractor with a quick hitch system.

SPECIFICATIONS:

Hitch:	Cat. I, ASAE Quick Hitch
Gearbox:	540 RPM
Deck Thickness:	11 Gauge
Deck Depth:	7 1/2"
Tailwheel:	3 3/4" x 15" Laminated
Cutting Height:	1" to 9"
Blade Size:	1/2" x 3"
Blade Pin:	1 1/2" Diameter
Driveshaft:	Shear Pin Protection or Slip Clutch

60" Mower with
Optional Chain
Shielding Shown



CAT I
A.S.A.E.
QUICK
HITCH
COMPATIBLE

FEATURES:

- Cuts up to 1" diameter material
- Flexible floating hitch follows contour of terrain
- Two 2" x 2" full length angles for main deck support
- Shielded series 4 PTO shaft
- Powder coated paint
- Optional - rubber or chain safety shielding

WARNING: If operating mower near roads and/or where people are present, you must equip mower with deck shielding.

MODEL NO.	CUTTING WIDTH	GEARBOX H.P.	OVERALL WIDTH	OVERALL LENGTH	BLADE TIP SPEED - FPM	WT.
RC200-48	48"	50 H.P.	52"	85"	13,090	510#
RC200-60	60"	65 H.P.	63"	98"	14,335	585#
RC200-72	72"	65 H.P.	76"	110"	14,955	710#

With I Beam Sides For Added Strength

"Flex-Hitch" Mowers

The New Rotary Mowers feature a Patent Pending "Flex-Hitch" that allows the mower to roll 15° front to rear and side to side. This allows the mower to follow the contour of the ground and is not available from other manufacturers. Another special feature is the sloped domed deck that sheds water and debris preventing material from collecting on the deck. Also, 6" full length I beams insure strength where the mower needs it the most. All these mower features were designed to insure years of trouble free service.



5' Mower with Optional Safety Chains

SPECIFICATIONS:

Model No:	Cut. Width	Overall Width	Overall Depth	Blade Tip Speed	Wt.
L-48-40-P-FH	48"	51"	82"	11,500	430#
L-60-40-P-FH	60"	63"	95"	12,500	535#
L-72-40-P-FH	72"	75"	107"	15,000	710#

FEATURES:

- Sloped, domed deck sheds water & debris
- No stitch welds, all fully welded seams
- Heavy round dished spindle pan for gearbox protection
- Two full length rails for deck support
- Heat treated heavy blades and blade bolts
- Color yellow- tractor colors available on request

Medium Duty Series

Model L72-60HD Shown with Optional Chain Shielding



FEATURES:

- Floating hitch design follows contour of terrain
- Heavy 8" I beam sides w/ribbed crossmembers
- Slip clutch driveshaft to prevent damage
- Forged heat treated blades and blade pins
- Optional safety shielding, front and rear
- Dual tailwheels for increased stability

- 3-PT. HITCH:** ASAE Cat. I, quick hitch compatible
- FLEX-HITCH:** Allows hitch to flex front to rear and side to side
- SIDE PLATES:** 6" I Beams full length
- GEARBOX:** 40 H.P. - 540 RPM
- TAILWHEEL:** Laminated rubber
- CUTTING HEIGHT:** 1" to 8"
- BLADE SIZE:** 1/2" x 3" w./ 1 1/2" Dia. Blade Pin
- DRIVESHAFT:** Shear Pin or Optional Slip Clutch

These Gearmore Rotary Mowers are the economical answer for medium duty use in weed and brush mowing. Special built-in features include floating hitch that follows the contour of the terrain, heavy round spindle pan to protect the gearbox, strong 8" I beam side channels for added strength, laminated tailwheel, and slip clutch driveshaft; all engineered to assure years of trouble-free service.

- SIDE RAILS:** 8" I Beams
- TOP DECK:** 3/16" Plate
- HITCH:** Cat. II
- GEARBOX RPM:** 540
- TAILWHEELS:** Laminated
- BLADE HOLDER:** Spindle Pan
- BLADE SIZE:** 1/2" x 4"
- DRIVESHAFT:** Slip Clutch

SPECIFICATIONS:

MODEL NO.	CUT. WIDTH	OVERALL WIDTH	OVERALL LENGTH	TAIL WHEELS	GEARBOX H.P.	WT.
L60-60-HD	60"	62"	86"	1	60 HP	800#
L72-60HD	72"	74"	92"	2	60 HP	1100#
L84-80HD	84"	86"	104"	2	80 HP	1480#



WARNING: If operating mower near roads and/or where people are present, you must equip mower with deck shielding.

Rotary Mowers

3-Pt. Hitch or Pull Type - 540 or 1000 RPM Tractors

10 Foot



These 10 foot wide rotary mowers are available in 3-point lift type or trailer pull type. For stability, both models are fitted with dual wheels supported with large 21" diameter laminated tires. The dual spindles are powered by 90 horsepower gearboxes. For added protection, a constant velocity driveline is provided. Designed for those tough mowing jobs and insures years of trouble free usage.

FEATURES:

- 2 - 90 HP, 540 RPM outboard gearboxes
- 125 HP, 540 RPM splitter gearbox
- 2" x 3" Tubular deck reinforcement
- Slip clutch gearbox protection
- 16,233 FPM blade tip speed
- 1/2" x 4" Swinging blades
- Cutting height - 1 1/2" to 12"
- Chain shielding - front & rear
- Up to 2" brush diameter
- Minimum PTO H.P. - 50
- 1/4" x 10" Side plates
- 7 Gauge deck (3/16")
- Round stump jumper
- Replaceable skid shoes
- Hitch type - Cat. II & III ASAE quick hitch or pull type

SPECIFICATIONS:

MODEL NUMBER	TYPE	CUT. WIDTH	OVERALL WIDTH	OVERALL LENGTH	MIN. PTO H.P.	WT.
270-120-L-SL-CG	3-Point	120"	10' - 4"	9' - 6"	50 H.P.	2250#
270-120-P-SL-CG	Pull Type	120"	10' - 4"	19' - 6"	50 H.P.	2725#

15 Foot



These large 15 foot rotary mowers feature 2 bat wings that hydraulically fold to 9 feet for transporting. These 1500 series mowers have heavy 7 gauge (3/16") steel decks, 1/4" side skirts, stump jumpers, reversible clevis hitch, and spring wheel shock absorbers. The dependable four gearbox design features slip clutch driveline and constant velocity input driveshaft. These mowers have been time tested in commercial, governmental and agricultural applications.

FEATURES:

- 125 HP, 540 RPM splitter gearbox *or*
- 180 HP, 1000 RPM splitter gearbox
- 3 - 90 HP gearboxes, 540 RPM *or*
- 3 - 140 HP gearboxes, 1000 RPM
- Spring cushioned wheel axles
- Blade tip speed - 15,000 FPM
- 7 Gauge deck thickness
- Round stump jumper
- Cat. 4 wing drivelines
- Cutting height 1" to 15"
- Cuts brush up to 2" diameter
- Self-leveling tongue
- Wing fold hydraulics
- Minimum PTO H.P. - 65
- 1/4" x 10" Side plate
- Skid shoes, wing
- Center section skid shoes
- Tongue jack
- Dual center wheels
- CV input driveline
- Wing cylinders - 3" x 12"
- Transport cylinder - 3" x 8"
- All cylinders and hoses included
- Safety chain front and rear

SPECIFICATIONS:

MODEL NUMBER	PTO R.P.M.	CUTTING WIDTH	TRANSPORT WIDTH	LENGTH	WT.
1550-DL-CG-CY	540 R.P.M.	15'	9'	15'	4875#
1510-DL-CG-CY	1000 R.P.M.	15'	9'	15'	4875#



Row Mulchers

A Versatile, High-Production Specialty Spreader

More and more vineyards and orchards are incorporating organic mulch and compost as a means to help reduce chemical usage.

The row mulcher makes large scale use of mulch feasible for any size vineyard or orchard. The machine applies neat, uniform rows of mulch right where you want.

"Millcreek Mulchers" are easy to adjust the spread pattern to suit your personal requirements. The removable cross conveyor allows for spread down row centers.



SPECIFICATIONS:

MODEL:	304	406	506	606	706	588	1028
Capacity, heaped:	4.4 yd ³ /3.4m ³	5.4 yd ³ /4.1m ³	6.7 yd ³ /5.1m ³	8 yd ³ /6.1m ³	9.3 yd ³ /7m ³	7.8 yd ³ /5.9m ³	13.5 yd ³ /10.3m ³
Maximum Payload:	3000 lbs 1361 kg	4000 lbs 1814 kg	3800 lbs 1723 kg	7800 lbs 3538 kg	7500 lbs 3402 kg	6000 lbs 2722 kg	10,500 lbs 4763 kg
Overall Width:	55"/139.7 cm	62"/157.5 cm	62"/157.5 cm	67"/170 cm	67"/170 cm	85"/216 cm	85"/216 cm
Overall Length:	15'/4.6m	16'-10"/5m	18'-10"/5.7m	20'-10"/6.3m	22'-10"/7m	16'-10"/5m	22'-10"/7m
Loading Height:	6' / 1.8m	6' / 1.8m	6' / 1.8m	6'-6" / 2.0m	6'-6" / 2.0m	6'-6" / 2.0m	6'-10"/2.1m
Body Width:	2'-6"/.8m	3'/9m	3'/9m	3'/9m	3'/9m	4'-6"/1.4m	4'-6"/1.4m
Body Length:	8'/2.4m	8'/2.4m	10'/3m	12'/3.6m	14'/4.3m	8'/2.4m	14'/4.3m
Body Height:	49"/124.5cm	49"/124.5cm	49"/124.5cm	49"/124.5cm	49"/124.5cm	49"/124.5cm	49"/124.5cm
Weight:	2100 lbs 953kg	2500 lbs 1134kg	2700 lbs 1224kg	3300 lbs 1497kg	3500 lbs 1588kg	3200 lbs 1452kg	4200 lbs 1905kg
Construction:	11-gauge, galvanized steel body on heavy channel chassis. 10-year poly floor						
Apron Conveyor Chain:	#662 Pintle	#662 Pintle	#662 Pintle	#667X Pintle	#667X Pintle dual apron	#662 Pintle dual apron	#662 Pintle
Tires:	9.5Lx15x8 Ply 24x38x20cm	11Lx15x12 Ply 28x38x30cm	11Lx15x12 Ply 28x38x30cm	14L x16.1x12 Ply 35x40x30cm	14Lx16.1x12 Ply 35x40x30cm	14Lx16.1x12 Ply 35x40x30cm	14Lx16.1x12 Ply 35x40x30cm
Hubs:	6 Bolt	6 Bolt	6 Bolt	8 Bolt	8 Bolt	8 Bolt	8 Bolt Dual Axle
Tractor Hyd. Drive:	Available	Available	Available	Available	Available	Available	N/A
PTO Mech. Drive:	N/A	Available	Available	Available	Available	Available	N/A
Walking Beam Axle:	N/A	N/A	N/A	Available	Available	Available	Standard
Minimum Tractor HP Required:	25 HP*	30 HP*	30 HP*	50 HP*	50 HP*	40 HP*	80 HP* Frt wts. may be req'd

* Follow tractor manufacturer's specifications for towing and weight limits.

MARKETED BY: GEARMORE, INC.

Model # AI-640-SNT

"NEW"



We custom build planting systems to growers individual requirements, see our website for details.

The Gearmore Precision Vacuum Planters are designed for extremely accurate vegetable seed placement. The P.T.O. driven turbine fan or optional hydraulic drive creates a vacuum that draws seeds against the seed plates. Inner and outer singulators remove doubles to insure that individual seeds are secured to the vacuum hole. At the seed release point, vacuum is cut off and the seed is deposited in the furrow. The air compressor then injects a short blast of air to insure the hole is clean for the next seed. Easy to operate and maintain, this durable precision planter efficiently handles the smallest of seeds either raw or coated.

Adjustable spring loaded parallelogram linkage for applying up or down pressure on the shoe opener

Simple, fast, screw type depth adjustment

Large monitoring window to visibly check seed pick-up

Rear wheel stainless steel or rubber

Clamp for H toolbar mounting

Quick disconnect on each planter drive for when no seeding is desired

Lock-out bar to hold planter up for transport

Stainless steel front wheel to smooth surface

Thin line shoe opener

Floating soil covering bars

Basket Rakes

Designed For Heavy Duty Usage



**MODEL 2030-G2
SHOWN WITH OPTIONAL
GAUGE WHEELS**

HIGH PRODUCTION BASKET RAKES

GENERATION 2 Twinstar Basket Rakes are designed for growers committed to producing superior quality hay. Twinstar Rakes produce consistent uniform windrows with less dirt, rocks, and debris than traditional wheel and rotary rakes. Twinstar models 2027 and 2030 are equipped with 7 tine bars which makes fluffier windrows, allows for increased raking time and higher ground speed. They are designed with double slide tubes for added strength. The baskets are now powered by heavy duty motors as standard equipment. The main hydraulic hoses fold and unfold in the unique Twinstar "Hose Trac" system. This clean, trouble free system gives total hose protection when extending and closing the double extension beams. Gauge wheels front and rear are optional equipment.

SPECIFICATIONS:

MODEL:	2024-G2	2027-G2	2030-G2
Maximum Raking Width:	Up to 24'	Up to 27'	Up to 30'
Transport Width:	11' - 3"	10' - 9"	10' - 9"
Transport Depth:	18'	20' - 2"	20' - 2"
Basket Sizes:	24" Diameter x 10 1/2' Long	30" Diameter x 10 1/2' Long	30" Diameter x 12' Long
Basket Reel Speed:	Maximum 90 RPM	Maximum 90 RPM	Maximum 90 RPM
Tine Bars:	5 Bars	7 Bars	7 Bars
Rubber Mounted Tines:	Std: 100 per basket - Option: 150	Std: 154 per basket - Option: 224	Std: 175 per basket - Option: 259
Operating Speed:	Up to 8 MPH	Up to 10 MPH	Up to 10 MPH
Hydraulic Requirements:	12 GPM @ 2000 PSI	12 GPM @ 2000 PSI	12 GPM @ 2000 PSI
Tire Size:	(4) ST205/75R15	(4) LT235/75R15	(4) LT235/75R15
Clevis Hitch:	Standard	Standard	Standard
Gauge Wheels:	Front and Rear - Optional	Front and Rear - Optional	Front and Rear - Optional
Ball Hitch 2 5/16":	Optional	Optional	Optional
Weight:	3500#	5100#	5600#



**LRU-7 RAKE
SHOWN**

CAT I
A. S. A. E.
QUICK
HITCH
COMPATIBLE



**LR20-72 RAKE W/OPTIONAL
GAUGE WHEELS SHOWN**

FEATURES:

- Cat. I, A.S.A.E. quick hitch compatible
- Five forward and reverse angle settings
- Maximum angle setting 45°
- Heat treated, replaceable tines
- Five forward and reverse angle settings
- 5/16" x 1" x 15" Spring steel tines
- 1" Spacing between tines
- Optional gauge wheels



**OPTIONAL DUAL CASTER
GAUGE WHEELS**

The rakes are ideal for general grooming, soil preparation, removing rocks, roots and debris, and spreading crushed rock or top soil. Five forward and reverse angle position for windrowing material. The reverse positions are great for pushing material into low spots.

We have two different series of rakes available, one for tractors up to 40 H.P. and one for tractors up to 60 H.P.

SPECIFICATIONS:

MODEL NO.	WIDTH	HORSEPOWER	NO. OF TEETH	WEIGHT
LR20-60	60"	20 to 40 H.P.	30	195#
LR20-72	72"	20 to 40 H.P.	36	212#
LRU-6	72"	30 to 60 H.P.	36	240#
LRU-7	84"	30 to 60 H.P.	42	270#
LRU-8	96"	30 to 60 H.P.	48	300#

Designed For Heavy Duty Use With High Horsepower Tractors

Ridgers

FEATURES:

- Cat. 2, 3-point A.S.A.E. quick hitch
- 4" x 4" x 1/4" Wall x 8' long toolbar
- Gangs adjust for tilt and pitch
- Self aligning trunnion bearings
- Available in 3 or 4 blade
- Blades on 9" centers with cast iron spacers
- Parking stand
- Optional mud scrapers



SPECIFICATIONS:

MODEL NO.	DESCRIPTION	REQUIRED HORSEPOWER	WEIGHT
BE222-3	3 Blade Ridger with 22", 24", & 26" Blades	60 Minimum H.P.	1000#
BE422-4	4 Blade Ridger with 22", 24", 26", & 28" Blades	60 Minimum H.P.	1080#

NOTE: 3 and 4 gang ridgers are also available for mounting on 2 1/4" diamond toolbar

Ridger Blockers

FEATURES:

- Ridger specifications same as above
- Blocker frame - 4" x 4" x 1/4" wall
- Toolbars are 8 feet long
- Blocker width 24" with 3/8" x 4" replaceable plow steel edge
- 3 1/2" x 8" Hydraulic cylinder with hoses



SPECIFICATIONS:

MODEL NO.	DESCRIPTION	REQUIRED HORSEPOWER	WEIGHT
BE222-3B	Complete 3 Blade Ridger with Blockers	60 Minimum H.P.	1200#
BE422-4B	Complete 4 Blade Ridger with Blockers	60 Minimum H.P.	1280#

Single Shank Rippers

3 Sizes Available For Up To 25, 50, & 75 Horsepower Tractors

GR100



GR100 - UP TO 25 HP

Great for cutting narrow trenches for irrigation pipe. The optional 12" furrower shovel digs a smooth trench for water flow.

GR200



GR200 - UP TO 50 HP

This unit is recommended for breaking up compacted soil to increase root growth and yields.

GR300

CAT II
A.S.A.E.
QUICK
HITCH
COMPATIBLE



GR300 - UP TO 75 HP

Designed for heavier duty use, thus the ripper can be used for high horsepower tractors. Recommend when deep ripping is required.

SPECIFICATIONS:

MODELS:	GR100	GR200	GR300
Horsepower Rating:	Up to 25	Up to 50	Up to 75
Frame Tube Size:	3" x 3"	4" x 4"	4" x 8"
Shank Length:	19"	23"	27"
Shank Size:	1" x 4"	1" x 6"	1" Parabolic
Hitch:	Cat. 1	Cat. 1	Cat. 2
Shear Bolt Protection:	Yes	Yes	Yes
Weight:	85#	130#	240#
Optional 12" Furrower:	Yes	No	No
Parking Stands:	No	No	Optional

V-Rippers

Narrow Widths For Vineyards and Berries
Wider Widths For General Farm Use

V-Rippers Cat. 1 - 30 to 50 H.P.

The "V" design main beam and curved shanks reduce horsepower requirements. The deep ripping obtains excellent soil aeration, which allows greater water penetration and absorption. Also increases root growth and penetration. All this adds up to better crops and higher profits.

FEATURES:

- Heavy 4" x 6" beam construction to insure long life
- 1" x 6" x 20" Shanks
- Shanks adjustable with shear bolt protection
- Replaceable high carbon, heat-treated points
- Parking stands that store in frame

SPECIFICATIONS:

MODEL NO.	NO. OF SHANKS	BEAM WIDTH	WEIGHT
R3-50	3	50"	420#
R3-60	3	60"	435#
R5-60	5	60"	550#
R3-70	3	70"	450#
R5-70	5	70"	570#



V-Rippers Cat. II & III

The "V" design main beam and curved shanks reduce horsepower requirements. The deep ripping aids in excellent soil aeration, which allows greater water penetration and absorption. Ripping increases root growth and penetration. All this adds up to better crops and higher profits.

FEATURES:

- "V" design & curved shanks reduce HP requirements
- Fixed and adjustable shanks available
- Shear bolt protection
- Replaceable high carbon, heat-treated points
- Parking stands that store in frame
- Optional gauge wheels for VR7F only

SPECIFICATIONS:

MODEL NO.	NO. OF SHANKS	HITCH CATEGORY	SHANK SIZE	MAX. H.P.	SHANK SPACING	BEAM SIZE	WEIGHT
VR3F	3	II	1" x 27"	80 HP	Fixed 30"	4" x 6" x 70"	675#
VR3	3	II	1" x 27"	80 HP	Adjustable	4" x 6" x 84"	715#
VR5F	5	II & III	1 1/4" x 34"	140 HP	Fixed 20"	6" x 8" x 90"	1300#
VR7F	7	II & III	1 1/4" x 34"	195 HP	Fixed 20"	6" x 8" x 130"	1525#



Rippers "GE" Series



MODEL No.
GE36-24 SHOWN

FEATURES:

- ❑ Cat. III & IVN 3-point A.S.A.E. quick hitch
- ❑ Frame made of 6" x 8" x 3/8" structural tubing
- ❑ "L" style shanks are 1 1/2" thick x 36" long
- ❑ 1" Thick "plow steel" lower hitch brackets
- ❑ Double dual steel wheels, 8" wide x 30" dia. (Optional on 5 shank rippers)
- ❑ Chrome shin guards on shanks - replaceable
- ❑ Heavy duty chrome chisel points - replaceable
- ❑ 1 1/4" Grade 5 swing shank bolts
- ❑ 1 1/4" Grade 2 shear shank bolts

OPTIONS:

- SW30 - Set of steel wheels for 5 shank ripper
- WW16 - Set of dual 11L x 16 rubber tires for 5 shank ripper
- WW16-7 - Set of dual 11L x 16 rubber tires in lieu of steel wheels for 7 shank ripper

SPECIFICATIONS:

MODEL NO.	NO. OF SHANKS	SHANK SPACING	FRAME WIDTH	WEIGHT
GE536-24	5	24"	8 Feet	3750#
GE536-30	5	30"	10 Feet	3910#
GE736-24	7	24"	12 Feet	4920#
GE736-30	7	30"	15 Feet	5050#

Crumbler Attachment "GTC" Series

FEATURES:

- ❑ Available in widths of 14, 15, 16, & 17 feet
- ❑ 5 Spiral crumbler paddles - 5/8" x 6"
- ❑ 10" Pipe center tubing
- ❑ 2 7/16" Ball bearings
- ❑ 2 7/16" Full length shaft
- ❑ Autolift no-shock arms
- ❑ 5" x 5" x 3/8" tubing main frame beam
- ❑ Mounting brackets are included
- ❑ Drop "S" from model no. for 7 straight paddles crumbler



SPECIFICATIONS:

MODEL NO.	DESCRIPTION	WIDTH	WT.
GTC-168-S	Crumbler Only	14 Foot	2600#
GTC-175-S	Crumbler Only	15 Foot	2760#
GTC-192-S	Crumbler Only	16 Foot	2920#
GTC-204-S	Crumbler Only	17 Foot	3080#

Manufactured by:

BWImplement

Heavy Duty V-Rippers "RS" Series

The "V" design of the shanks are available in standard curved or parabolic style. Both types of deep ripping shanks obtain excellent soil aeration, which allows greater water penetration and absorption. Also increases root growth and penetration. The rippers are very effective for first pass soil preparation for easier discing and other finish tilling implements.

FEATURES:

- V frame is constructed with 6" x 8" x 3/8" tubing
- Standard curved design shanks - 1 1/4" x 31" long
- Shanks also available 1 1/4" x 34" in standard and parabolic design
- Chrome shin guards and points
- Shank pockets are available as fixed or adjustable
- Horsepower required is 25 HP per shank
- Gauge wheels available as single or dual - 9.5L x 15
- Cat. II or III, 3-point hitch (please specify)



7 SHANK WITH OPTIONAL SINGLE GAUGE WHEELS & PARABOLIC SHANKS SHOWN

SPECIFICATIONS:

MODEL NO.	DESCRIPTION	WIDTH	WT.
RS-30HD	3 Shank V Ripper	5' - 3"	1200#
RS-50HD	5 Shank V Ripper	8' - 2"	2200#
RS-70HD	7 Shank V Ripper	13' - 8"	2800#
RS-90HD	9 Shank V Ripper	15' - 6"	3500#

Ripping Chisels "GRC" Series

Our 3 bar finishing Ripper Chisel is an effective implement for loosening soil up to 15 inches deep. The rigid shank design insures consistent depth. The narrow 12" shank spacing is excellent for breaking up and incorporating of residue. These ripping chisels are the perfect tool for opening up heavy soils for aeration. The shear bolt shanks allow for higher speeds than most tillage implements.

FEATURES:

- Cat. III & IV narrow, 3-pt. quick hitch compatible
- Frame 5" x 5" x 3/8" wall steel tube
- 3 Shank beams on 36" center
- Beam cross braces 5" x 5" x 3/8" wall
- 4 Tubing braces to support top mast
- 1 1/4" x 30" Rigid plow steel shanks w/shear bolt

SPECIFICATIONS:

MODEL NO.	WIDTH	DESCRIPTION	NO. OF SHANKS	WT.
GRC-15	15 ft.	Ripper Complete	15	4450#
GRC-17	17 ft.	Ripper Complete	17	4750#
GRC-19	19 ft.	Ripper Complete	19	5050#
GRC-21	21 ft.	Ripper Complete	21	5350#

Other Widths Available Upon Request



21' MODEL SHOWN W/SINGLE GAUGE WHEELS & OPTIONAL REAR HITCH & POINTS

- Welded plow steel shank pockets
- Shanks are on 12" centers
- Single gauge wheels - 9.5L x 15

OPTIONS:

- 3/4" x 15" Reversible spike points
- Rear clevis hitch
- Dual gauge wheels (in lieu of single)

Manufactured by:

BWI Implement

"RDB" Series Ripper Bedders



MODEL RDB-32 SHOWN

Our Ripper Bedders primary function is to eliminate crop residue after harvest, allow the grower a shorter turn around time and minimize the passes through the field. The Ripper Bedders are a 3 in 1 implement, as they rip, disc, and bed all in one pass. The front shanks deep rip the soil, the two sets of adjustable disc gangs loosen the soil and discs in the crop debris. The cone coultter blades then re-build the beds. After the first pass, the integrity of the row is maintained when additional passes are desired. These Ripper Bedders are popular for building or re-working beds on most vegetable crops.

Also, these units are an excellent implement for re-working field tomato beds after harvest, without disturbing irrigation tape.

SPECIFICATIONS:

MODEL NO.	DESCRIPTION	BED SIZE	TOTAL NO. OF BLADES	NO. OF SHANKS	WEIGHT
RDB-16	1 - Row Ripper Bedder	80"	16	2	2850#
RDB-32	4 - Row Ripper Bedder	40"	32	5	4825#
RDB-36	3 - Row Ripper Bedder	60"	36	4	5525#
RDB-48	3 - Row Ripper Bedder	80"	48	4	6250#

Bed Shapers



MODEL SLP3-80F 3-Row, 80" BEDS



Our bed shapers provide a basis for precision guidance for vegetables which require a smooth, clean, firm seedbed for proper planting. The uniform seed beds are required to insure, not only for planting, but for all the other required operations such as: cultivating, sidedressing, thinning, and spraying.

The bed shapers feature replaceable wear resistant non-stick UHMW plastic bed top liners, and A.R. abrasion resistant steel furrow shapers the full length of the bed shaper. These bed shapers can easily be adapted for planters and cultivators.

SPECIFICATIONS:

MODEL NO.	CAT. HITCH	FRAME	NO. OF ROWS	BED CENTERS	WT.
SLP4-40	Cat. II - III	Fixed	4	40"	1900#
SLP3-60	Cat. II - III	Fixed	3	60"	2100#
SLP3-80	Cat. II - III	Fixed	3	80"	2600#
SLP3-80F	Cat. II - III	Folding	3	80"	3200#
SLP5-60	Cat. III	Fixed	5	60"	4100#
SLP5-60F	Cat. III	Folding	5	60"	4600#

Manufactured by:

BWImplement

"BSL" Series

FEATURES:

- For compact tractors up to 24 H.P.
- Heat treated scarifier shanks with replaceable points
- Clevis type hitch brackets
- Side plates are 1/4" x 16" x 22"
- Main beam 1/4" x 4" x 4" tubing

SPECIFICATIONS:

MODEL NO.	CUTTING WIDTH	NO. OF SHANKS	WT.
BSL-42	42"	3	275#
BSL-48	48"	4	290#



"20" Series



FEATURES:

- For tractors up to 40 H.P.
- 4" x 4" Main beam
- 1/4" x 17" High x 24" deep side plates
- 4 Position adjustable shanks
- Clevis type hitch pins
- 1/2" x 6" Reversible cutting edges

SPECIFICATIONS:

MODEL NO.	WIDTH	SHANKS	WT.
BB20-48	48"	4	340#
BB20-54	54"	4	375#
BB20-60	60"	5	400#
BB20-66	66"	5	420#
BB20-72	72"	6	445#

"BB" Series

SPECIFICATIONS:

MODEL NO.	WIDTH	SHANKS	WT.
BB-48	48"	4	350#
BB-54	54"	4	385#
BB-60	60"	5	415#
BB-66	66"	5	435#
BB-72	72"	6	500#
BB-84	84"	6	530#

FEATURES:

- For tractors up to 50 H.P.
- 4" x 4" Shank beam
- Clevis lower hitch brackets
- Adjustable heat-treated scarifier shanks with replaceable points
- 17" High self cleaning moldboard



Box Scrapers

Available With 3 Separate Shank Retracting Systems - Manual, Mechanical, & Hydraulic

GBS SERIES



CAT 1
A.S.A.E.
QUICK
HITCH
COMPATIBLE

GBS/R SERIES



GBS/H SERIES



FEATURES:

For Cat. 1 tractors of up to 40 H.P. 4 wheel drive and 50 H.P. 2 wheel drive, ASAE Quick Hitch

3 types of shank adjustments to choose from: MANUAL, MECHANICAL and HYDRAULIC

Designed so that shanks retract straight up, thus improves view of cutting edge and reduces machine weight (GBS/R & GBS/H)

Positive locking system in both engaged and retracted positions

Adjustable heat-treated scarifier shanks with replaceable points

1/2" x 6" Reversible cutting edges front and rear

Side plates are 1/4" thick x 18 1/2" high x 26 1/2" long - 72" and up are 3/8" thick

Clevis type hitch points

4" x 4" Steel tubing main beam

Sizes to fit your width requirements

SPECIFICATIONS:

CUTTING WIDTH	OVERALL WIDTH	NO. OF SHANKS	WEIGHTS		
			GBS	GBS/R	GBS/H
42"	42 1/2"	3	330#	360#	360#
48"	48 1/2"	4	355#	405#	405#
54"	54 1/2"	4	395#	435#	435#
60"	60 1/2"	5	440#	480#	480#
66"	66 1/2"	5	490#	505#	505#
72"	72 3/4"	6	540#	575#	575#
76"	76 3/4"	6	560#	600#	600#
80"	80 3/4"	7	600#	630#	630#
84"	84 3/4"	7	620#	665#	670#

Industrial Box Scrapers

For Tractors 15 to 60 Horsepower

The **2G1 Series Scrapers** are designed especially for small compact tractors. Available in widths of 42", 48", 54" & 60" for tractors from 15 to 40 HP, 2 or 4 wheel drive.



CAT I
A. S. A. E.
QUICK
HITCH
COMPATIBLE



The **2G2 Series Scrapers** are ideal for general landscape work such as: terracing, back-filling, scarifying and leveling the soil. Available in widths of 60", 66", 72", 76", & 84" for tractors from 30 to 60 HP, 2 or 4 wheel drive. Available in manual or hydraulic shanks. Now with bushings on 3-point hitch.

Unique hydraulic scarifier system raises scarifier to high clearance position and lowers beam to working position plus automatically self-locks with heavy hardened pin

SPECIFICATIONS:

MODELS:	2G1 SERIES				2G2 SERIES				
	2G1-42	2G1-48	2G1-54	2G1-60	2G2-60	2G2-66	2G2-72	2G2-76	2G2-84
Working Width:	42"	48"	54"	60"	60"	66"	72"	76"	84"
Overall Width:	42 1/2"	48 1/2"	54 1/2"	60 1/2"	60 3/4"	66 3/4"	72 3/4"	76 3/4"	84 3/4"
No. of Shanks:	4	4	5	5	5	6	7	7	7
Approx. Weight:	410#	445#	480#	520#	770#	830#	860#	890#	920#
Moldboard Height:	18"				21"				
Main Beam:	1/4" x 4" x 4"				3/8" x 4" x 4"				
Side Plates:	1/4" x 18" x 28"				3/8" x 21" x 33"				

Available With Fixed or Floating Tailboard

For Tractors 50 to 100 Horsepower

The **4G2 Series Scrapers** are designed to handle the demanding work of commercial landscaping and finish grading with its floating tailboard. Available in widths of 72", 76", 80" & 84" for tractors 50 to 70 HP, 2 or 4 wheel drive. Can be built to be A.S.A.E. quick hitch.



The **4G4 Series Scrapers** are extremely rugged and ideal for construction site clean-up, trench back-filling and demanding material handling. Available in widths of 80", 84" & 88" for tractors 60 to 100 HP, 2 or 4 wheel drive.

The **4G5 Series Scrapers** were developed for grading contractors with high horsepower tractors that demand floating tailboard scrapers. The scraper was designed with 4G4 strength, but the versatility of the floating tailboard. In float position, the cutting of hard material is much greater over fixed tailboard units. Available in widths of 80" & 84" for tractors 65 to 85 HP, 2 or 4 wheel drive.



SPECIFICATIONS:

MODELS:	4G2 SERIES				4G4 SERIES			4G5 SERIES	
	4G2-72	4G2-76	4G2-80	4G2-84	4G4-80	4G4-84	4G4-88	4G5-80	4G5-84
Working Width:	72"	76"	80"	84"	80"	84"	88"	80"	84"
Overall Width:	73"	77"	81"	85"	81"	85"	89"	81"	85"
Approx. Weight:	1150#	1190#	1220#	1260#	1340#	1400#	1470#	1350#	1410#
Side Plates:	1/2" x 24" x 32"				1/2" x 24" x 35"			1/2" x 24" x 35"	
HP Rating:	50 to 70 Horsepower				60 to 100 Horsepower			65 to 85 Horsepower	

Corral Scrapers

FEATURES:

- Designed to move a lot of material fast
- Heavy duty, large capacity, all welded construction
- Features 24" high x 36" deep x 3/8" thick side plates
- Combination Cat. 1 and 2 clevis hitch
- Stepped, non-turning, combination Cat. 1 & 2 lower link pins
- Square tube main beam 4" x 4" x 1/4"
- Rear moldboard 1/4" thick

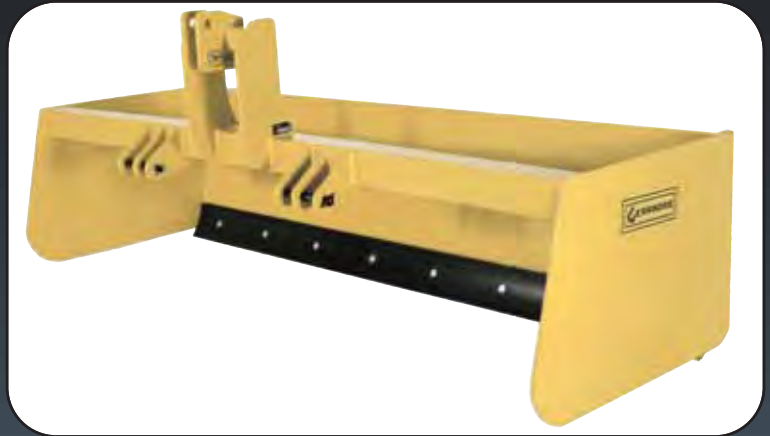

SPECIFICATIONS:

MODEL NO.	WIDTH OF CUT	CAPACITY	WEIGHT
CS72	72"	36 cu. ft.	660#
CS84	84"	42 cu. ft.	700#
CS96	96"	48 cu. ft.	740#
CS120	120"	60 cu. ft.	800#

1/2" x 6" Single reversible high-carbon cutting edge

Compact Drag Scrapers

SPECIFICATIONS:

Working Widths:	5, 6, and 7 Foot
Moldboard:	1/4" x 18"
Side Plates:	3/8" x 18" x 24"
Tongue:	Removable 3/16" x 3" x 3"
Tires:	Equipped w/(2) 5.70-8 tires
Hydraulics:	2" x 6" double acting cylinder & hoses
Clearance:	Raised: 12" - Cuts: 3" Below grade
Approx. HP:	25 to 50 Horsepower
Capacity:	(5')-7/16 cu. yd., (6')-1/2 cu. yd., (7')-5/8 cu. yd.
Weight:	(5') - 500#, (6') - 550#, (7') - 600#



FEATURES:

- Extremely versatile-countless jobs can be done all year round. Level ditches, clean sheds and pens, repair roads, spread gravel, general earth-moving
- Hydraulically operated and controlled from your tractor seat

- Now with removable tongue
- Highly maneuverable - makes turns loaded & unloaded
- Cutting edges are 1/2" x 6" high carbon and reversible
- Scrapers come standard with tires, cylinder, and hoses
- Clevis type hitch

OPTION:

- ~ Tilt axle assembly

All-Purpose Drag Scrapers

Our Drag Scrapers are an excellent implement for carrying and spreading all types of material. Land-scapers find the scrapers great for general grading and spreading exact depths of top soil. Contractors set the cutting edge to spread different depths of gravel for rebuilding roads and storage yards. Dairy men find the scrapers best for moving you know what. The Drag Scrapers feature a removable 4" x 4" beam tongue that extends to the rear moldboard and is held in place by a 5" x 5" heavy gusseted tube. This feature gives added strength at the point of the most stress.

FEATURES:

- For tractors 70 to 120 horsepower
- Working widths of 8, 10, & 12 foot
- 3/8" x 24" x 36" Deep side plate
- Clearance of 23" raised and 5" below grade
- Hydraulically operated from the tractor seat
- Moldboard 1/4" plate, 24" high
- Main cross beam 4" x 4" tubing
- 3" x 8" Double acting cylinder and hoses



**MODEL AP10 SHOWN
WITH OPTIONAL DUAL
WHEELS & TILT**

SPECIFICATIONS:

MODELS	WIDTH	CAPACITY	WT.
AP8	8'	1 3/4 cu. yd.	1430#
AP10	10'	2 1/4 cu. yd.	1525#
AP12	12'	3 cu. yd.	1895#

- Ribbed implement tires - 9.5L - 15SL
- Bolt-on hitch with swivel ball

OPTIONS: Tilt Axle w/cylinder & hoses,
Dual Wheels
Bolt-on Weight Boxes

High Capacity Drag Scrapers



MODEL HC10 SHOWN

The "HC" High Capacity Series of Drag Scrapers feature heavy, large side plates - 1/2" thick. These side plates are 30" high by 40" deep, thus allowing for dragging and depositing large amounts of material. Like the "AP" series, the beam tongue extends to the rear moldboard and is held in place by a 5" x 5" heavy gusseted tube. The new axle assembly is built with 4" x 2" tubing. The larger dairies and feedlots find these scrapers best for their operations.

FEATURES:

- For tractors 70 to 120 horsepower
- Working widths of 8, 10, & 12 foot
- 1/2" x 30" x 40" Deep side plates
- Clearance of 23" raised and 5" below grade
- Hydraulically operated from the tractor seat
- Moldboard 1/4" plate, 30" high
- Internal braces to side plates and moldboard
- Main cross beam 4" x 4" tubing
- 3" x 8" Double acting cylinder and hoses
- Ribbed implement tires - 9.5L x 15

SPECIFICATIONS:

MODELS	WIDTH	CAPACITY	WT.
HC8	8'	2 1/2 cu. yd.	1450#
HC10	10'	3 1/4 cu. yd.	1630#
HC12	12'	3 3/4 cu. yd.	2100#

- Bolt-on swivel slotted hitch

OPTIONS: Tilt Axle w/cylinder & hoses,
Dual Wheels
Bolt-on Weight Boxes

Compact & Industrial Series

The **Gearmore Grading Scrapers** were designed to perform many different tasks, such as: landscaping, road repair, arena maintenance, etc. Many unique features enable the operator to do a number of different tasks, no matter what the soil conditions.

General Landscaping - The deep ripping scarifier shanks will break-up the hardest of soils. Dual cutting blade will allow for the movement of large amounts of material when required. To finish grade, set the shanks in the storage position and lightly grade, to finish your landscaping project.

Repairing Roads - The dual blade flow through action cuts out high spots, fills holes and moves material from the edge of the road toward the center, thus achieving a smooth finished road.



Now available less shanks



FEATURES:

- Quick hitch compatible
- For tractors from 20 to 80 horsepower
- Heavy steel tubing main front beam
- Heavy steel tubing rear support beam
- Heat treated scarifier shanks with replaceable points
- Shanks adjust to ripping & storage positions
- Two 1/2" x 6" heat treated reversible beveled cutting edges
- Easy to adjust cutting edges with settings of 1 to 1 1/2" below side panels (preset at 1/4")
- Formed side panels capture and retain material
- 1/4" x 2" Replaceable skid plates on side panels

SPECIFICATIONS:

MODEL NO.	HITCH TYPE	CUTTING WIDTH	OVERALL WIDTH	MIN. H.P.	MAIN BEAM	WT.
GS4	Cat. 1	48"	52"	20 HP	3" x 3"	415#
GS5	Cat. 1	60"	64"	25 HP	3" x 3"	450#
GS6	Cat. 1	72"	76"	30 HP	3" x 3"	505#
GSI7-SS	Skid Steer	84"	89"	45 HP	5" x 5"	820#
GSI7	Cat. 1 & 2	84"	89"	45 HP	5" x 5"	830#
GSI8	Cat. 2	96"	101"	50 HP	5" x 5"	860#
GSI10	Cat. 2	120"	125"	70 HP	5" x 5"	1020#
GSI12	Cat. 2	144"	149"	80 HP	5" x 5"	1140#

Grading Scrapers

Skid Steer, Track Loader & 3-point Tractor Mount

By:

Level Best®

Compact Grading Scrapers

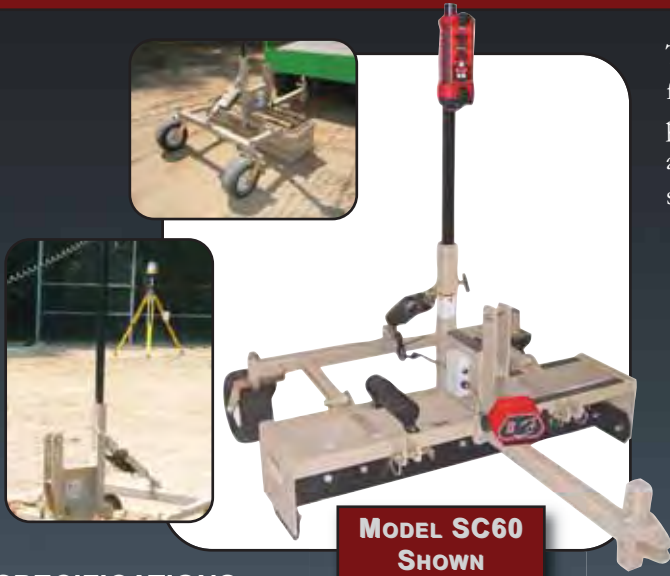

MODEL SC60 SHOWN

SPECIFICATIONS:

MODEL	BOX SIZE	PTO H.P.	CAP.	WT.
SC48	48"	20 H.P.	4.1	345#
SC54	54"	20 H.P.	4.6	365#
SC60	60"	20 H.P.	5.1	395#
SC66	66"	20 - 25 H.P.	5.6	410#
SC72	72"	20 - 25 H.P.	6.1	425#

The compact series of grading scrapers are available in 3-point hitch for tractor mount or towable for utility or all terrain vehicles. Horsepower requirements are approximately 20 H.P. The scraper is available with linear electronic or hydraulic and without laser grading system.

FEATURES:

- Durable steel construction of 3/8" & 1/4" steel plate & heavy wall steel tubing to take daily abuse on a job site
- Rugged casters with wheel hubs and tapered roller bearings
- Composite epoxy - fiberglass bushings in all pivot points eliminates the need for greasing
- Wide, flat free tires eliminates tire repair & leaves less tire track
- High carbon steel replaceable cutting edges on moldboard and side plates
- Available with hydraulic or electronic liner actuator compatible with most laser systems
- 4 Flootation tires on super capacity scraper
- Optional drawbar hitch, scarifier bar, & rear hinged cutting edge - standard capacity only
- Tough, long-lasting, powder coated paint reduces rust/corrosion

Grading Scrapers

These Scrapers are usually sold with the optional laser grading system, as it allows the scrapers to finish grade elevations to within 1/4 inch. The top of the line Para Level Scraper is the smoothest operating system, as the grading box adjusts independently from the skid steer and the floatation wheels. The double box on the Para-Level also allows grading in forward and reverse. These high strength scrapers are designed to give years of trouble free use.

FEATURES:

- Durable steel construction of 3/8" & 1/4" steel plate & heavy wall steel tubing
- Rugged casters with wheel hubs and tapered roller bearings withstand years of punishment
- Composite epoxy - fiberglass bushings in all pivot points eliminates need for greasing
- Wide, flat free tires eliminates tire repair & leaves less of a tire track
- High carbon steel replaceable cutting edges on moldboard and side plates
- Hydraulic packages designed to fit most popular laser systems
- Tough, long-lasting, powder coated paint reduces rust and corrosion

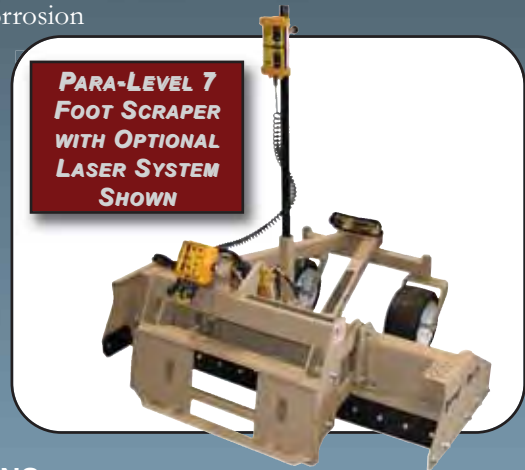

SPECIFICATIONS:

MODEL	BOX SIZE	PTO H.P.*	BOX CAP.		WT.
Skid Steer Para-Level Grading Box, Double			Front	Rear	
PL72	6'	60 +	11.5 cu. ft.	7 cu. ft.	1530#
PL84	7'	70 +	13.4 cu. ft.	8 cu. ft.	1590#
PL96	8'	80 +	15.3 cu. ft.	9 cu. ft.	1650#

* Recommended horsepower under optimal conditions. Custom sizes available.

Optional Laser Scraper Models - Para-Level Slope includes Slope-Tach for cross-slope operation.

Grading Scrapers

SPECIFICATIONS

MODEL	BOX SIZE	PTO H.P.*	BOX CAPACITY	WEIGHT
Standard Capacity Tractor Grading Box				
LBS6	6'	30 to 42	17.0 cu. ft.	1060#
LBS7	7'	35 to 49	19.9 cu. ft.	1120#
LBS8	8'	40 to 56	22.8 cu. ft.	1180#
Super Capacity Tractor Grading Box				
LBSE8	8'	70 to 90	37.5 cu. ft.	1750#
LBSE9	9'	80 to 100	42.3 cu. ft.	1835#
Optional Laser Scraper Models - Double Box Scraper includes cross-slope operation.				



FEATURES:

Same features as Para-Level plus:

- 4 Flootation tires on super capacity scraper
- Optional drawbar hitch, scarifier bar, & rear hinged cutting edge - standard capacity only

These two series of 3-point hitch grading scrapers are available in standard or super capacity. The standard capacity scrapers are available in Cat. I & II and can be operated with tractors as low as 30 PTO horsepower. The super capacity scrapers are Cat. II only and can be operated with tractors as low as 60 PTO horsepower. Both series of scrapers are available with or without laser grading system.

Laser Systems

Laser Mounted Grading Systems were designed to replace the traditional three person grading crew with a single operator. The units will finish grade elevations to within 1/4 inch. The laser controls are easy to learn and use. As the operator grades, the system's receiver detects laser light from the rotating beacon and transmits a signal to the scraper hydraulic controls. The hydraulic valve uses the signal from the receiver and automatically lowers or raises the grading box to the required grade. Precise finish grade is attained when the "on grade" light remains illuminated.



Hydraulic Pkg



Apache



Grado Plane 15



Grado Plane 25

To make grading scrapers into laser grading scraper 3 components are required:

1. Hydraulic System
2. Laser System
3. Tripod Mounted Rotating Laser Beacon

1. HYDRAULIC PACKAGE

Consists of digitally proportional valve, hoses, fittings, & hardware for the following laser systems:
Apache - Trimble

2. LASER CONTROLS

The controls consist of control panel, 360° sensor, cables, and manual override.
Apache

3. ROTATING LASER BEACONS

The tripod mounted rotating laser beacons are either single slope or dual slope.

ROTATING LASER BEACONS

- Tripod mounted rotating laser beacons provide either single or dual/cross slope features
- Automatic or manual programming with remote
- Self leveling and H.I. Alert
- 1,000 to 3600 Foot diameter range
- Tripod, Grade Rod, and Detectors suitably matched to application

Implements To Make Your Skid Steer & Track Loader More Productive

Vibratory Roller



- Drums available in widths of 48", 66", 73" & 84"
- Drums available in smooth or padded
- Dynamic force (pounds) from 5,750 to 9,370
- Maximum flow 25 gallons per minute
- Vibrating speed of 2600 vibrations per minute

Root Rake



- Dual use - rip out roots and grapple material
- Widths of 72", 78" & 84"
- 49" Grapple opening
- Dual hydraulic cylinders
- Built for extreme duty use

Trencher



- Available in digging depths of 36", 42" & 48"
- Trench digging widths of 6", 8" & 10"
- Equipped w/2 position side shift
- High torque hydraulic motor for maximum digging power
- Replaceable headshaft driven auger for spoil removal

Rotary Tiller



- Widths of 52", 66" & 78"
- Models in offset or center mounted
- Motors from 14 to 44 gallons per minute
- Built-in scarifier

Cold Planer



- High flow and standard flow models are available
- Planing widths of 12", 16", 18", 24", 30" & 40"
- Fully adjustable with electro-hydraulic controls
- Joystick controls for depth, tilt, and side shift
- Drum diameters of 19" & 22" with carbide picks

Backhoe



- Available in digging depths of 8 1/2' thru 12'
- Bucket sizes of 12", 16", 18", 20", 24" & 36"
- Dual cylinder swing provides max. power where needed
- Cushioned swing brings backhoe to gentle stop at each end of the swing arc
- Operates with Skid Steer tractors with hydraulic systems of only 9 to 12 G.P.M.

Manufactured by:



Implements To Make Your Skid Steer & Track Loader More Productive

Dozer Blade



- Available in widths of 84" and 96"
- Rated for tractors up to 110 H.P.
- Electro hydraulic controlled angle and tilt
- Heavy moldboard - .31" thick and 28" high
- Replaceable cutting edge and skid shoes

Mulcher



- 60" Cutting width
- Shreds up to 8" diameter trees
- Hydraulic deflector door
- 45 Hammers with carbide teeth
- Hydraulic flow of 30 to 60 G.P.M.

Hydraulic Mower



- Available in 60" and 72" widths
- High speed dual blades for brush up to 3" diameter
- Heavy 1/4" thick steel deck with formed side plates
- Skid shoes for added strength and rigidity
- Side discharge to allow shredded material to exit quicker

Quick Attach Low Profile Material Buckets



- Widths of 60", 66", 72", 78", & 84"
- Standard 30" length for more severe conditions when break out force is required
- Long length floor of 36" for better visibility, productivity, and cutting grade
- Strong box sections and full wear strips for better bottom protection
- Designed with 20° rollback angle

Quick Attach Scrap Grapple Buckets



- 2 Series of buckets in widths of 60", 66", 72", 76", 82", & 88"
- For machine weights of 8,000 and 11,000 lbs.
- Patented cushioned and sleeved cylinder
- Steel guards to protect cylinders
- Load check valve system

Quick Attach Grapple Brush Buckets



- 2 Series of buckets in widths of 66", 72", 78", 84", & 90"
- For machine weights of 8,000 & 20,000 lbs.
- Patented cushioned & sleeved cylinder
- 100,000 PSI yield strength tine material
- Load check valve system

Manufactured by:



Compact Skid Steer Attachments

Rock Bucket



- ❑ 42" Wide
- ❑ 2" Tine spacing
- ❑ Alloy steel tines - 3/4" or 1 1/8" dia.
- ❑ Sifts out dirt, removes debris

615 Trencher



- ❑ 24", 30" or 36" Dig. depths
- ❑ 6" to 12" Wide chains
 - Standard tooth
 - Shark style tooth or
 - Combo chains
- ❑ Offset footing model available

Auger Drives

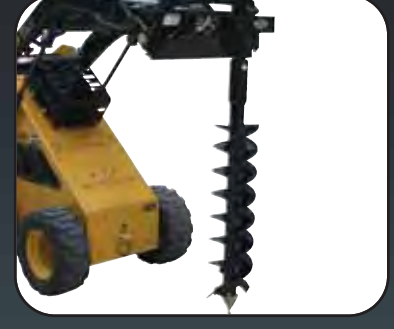

- ❑ Models X900 & X1500
- ❑ 2 9/16" Round or 2" square output shafts
- ❑ X900 High speed
- ❑ X1500 High torque

4-In-1 Bucket



- ❑ Available in widths of 38" & 42"
- ❑ Dual hydraulic cylinder
- ❑ Dozers, carries, and clamps material
- ❑ Operating pressure of 1500 to 3000 PSI

Tiller



- ❑ 40" Tilling width
- ❑ Adjustable depth shoes
- ❑ 5" Tilling depth
- ❑ 8 to 15 GPM recommended

Manufactured by:



Three Separate Finish Tilling Functions

FEATURES:

- ❑ Easy to adjust and operate
- ❑ Travel speeds up to 8 miles per hour
- ❑ Minimum investment cost and low maintenance
- ❑ Total soil mixing also causes faster water penetration to the root zone
- ❑ Completely mixes soil, does not fold it over or move it to the side like a disc
- ❑ Leaves ground perfectly level, as ridges are knocked down and holes are filled-in
- ❑ 20" High clearance "S" tines to penetrate and till up to 7" deep
- ❑ "S" tines are heavy duty 1/2" x 1 3/4" x 26" spring steel
- ❑ Heat-treated, 3/4" x 11" spikes on 6" centers
- ❑ Spring loaded, 12" diameter rolling crumbler with serrated bars angled to finish mulching the soil
- ❑ Tapered frame permits traveling through vegetation without damaging it
- ❑ Tapered rolling crumbler yokes, on all models, guide material around baskets

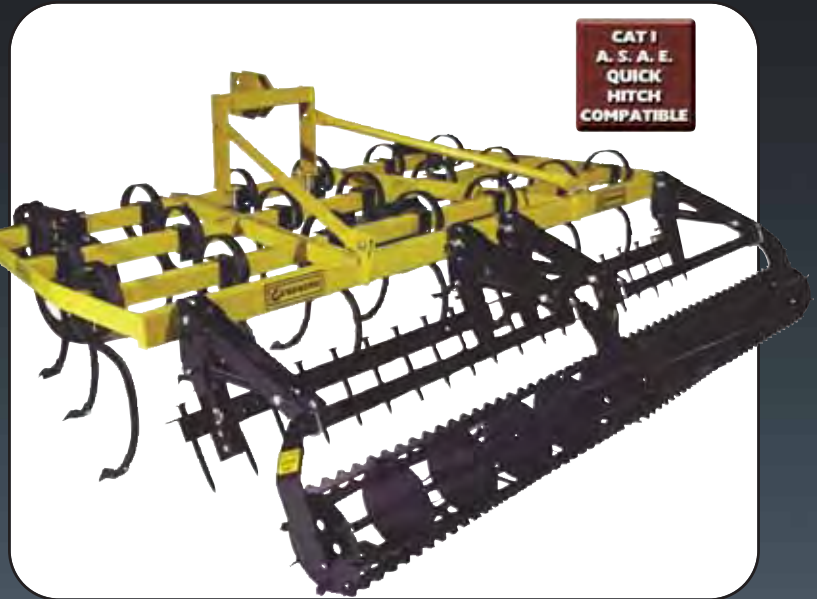

This unique tool from Gearmore combines heavy-duty "S" tines to break the soil. A spring loaded spike tooth bar follows the "S" tines to level the soil and break clods. Then the aggressive spring loaded rolling crumbler completes the work by creating a fine, level surface.

SPECIFICATIONS:

MODEL NO.	WIDTH	"S" TINE BARS	NO. OF "S" TINES	NO. OF TEETH	ROLLING CRUMBLERS	WEIGHT
GSC4	4'	2	7	8	1 - 4'	475#
GSC5	5'	3	9	10	1 - 5'	620#
GSC6	6'	3	11	12	1 - 6'	800#
GSC7	7'	3	13	14	1 - 7'	900#
GSC8	8'	3	15	16	1 - 8'	1000#
GSC10	10'	3	19	20	2 - 5'	1300#
GSC12	12'	3	23	24	2 - 6'	1620#
GSC13	13'	3	25	26	1 - 6' & 1 - 7'	1700#
GSC14	14'	3	27	28	2 - 7'	1840#
GSC15	15'	3	29	30	3 - 5'	1900#

Cultivators 4 to 7 feet are Cat. 1 - Cultivators 8 to 15 feet are Cat. 2

Sprayers

Spot • ATV • Utility • Skid • Trailer • 3-pt.

LG-13-P



LG-40-SS



LG-29-P



LG SPOT SERIES 15, 25, & 40 GALLON CAPACITY

- Corrosion resistant polyethylene tank
- Full length drain sump
- 5" Fill lid with tether
- Larger hose wrap horns for hose storage
- Both gallon & liter fluid volume indicator on tank
- 12 Volt (demand) diaphragm pump
- Maximum horizontal throw - 30 ft.
- Maximum vertical throw - 18 ft.
- Ready for Roundup

MODELS	GALLONS	G.P.M.	PSI	HANDGUN	HOSE	WEIGHT
LG-13-P	15	2.1	60	Lever	15'	20#
LG-29-P	25	2.1	60	Lever	15'	24#
LG-40-SS	40	3.8	45	Pistol Grip	25'	50#

UTL-40-5



UTL-40-12V-BL



UTL SERIES 40 GALLON CAPACITY

- Corrosion resistant polyethylene tank
- Mount easily in most utility vehicles and pickups
- Large pickup sump
- Both gallon & liter fluid volume indicator on tank
- 12 Volt (demand) diaphragm pump
- Adjustable pressure and gauge
- Ready for Roundup

MODELS	GALLONS	G.P.M.	PSI	HANDGUN	HOSE	BOOM NOZZLES	COVERAGE	WT.
UTL-40-5	40	2.1	60	Pistol Grip	25'	5	100"	117#
UTL-40-12V-BL	40	3.8	45	Pistol Grip	25'	3	30'	108#

TRAILER & BOOM SERIES 25 & 40 GAL. CAPACITY

- Corrosion resistant polyethylene tank
- Full length drain sump
- 5" Fill lid with tether
- Ready for Roundup
- Larger hose wrap horns for hose storage
- Both gallon & liter fluid volume indicator on tank
- 12 Volt (demand) diaphragm pump
- Adjustable pressure and gauge

LG-2500-303



TR-40-EX



MODELS	GALLONS	G.P.M.	PSI	HANDGUN	HOSE	BOOM NOZZLES	COVERAGE	WT.
LG-2500-303	25	2.1	60	Lever	15'	2	80"	55#
TR-40-EX	40	2.1	60	Pistol Grip	25'	5	100"	155#

TRAILER & SKID 60 GALLON CAPACITY

- Corrosion resistant polyethylene tank
- Mount easily in most utility vehicles and pickups
- Full drain out capacity with molded in drain port
- Both gallon & liter fluid volume indicator on tank
- 12 Volt (demand) diaphragm pump 12V
- 2.5 HP gas engine & roller pump 4R
- Pressure gauge
- Available in cast iron or silvercast pump



MODELS	GALLONS	TYPE	G.P.M.	PSI	HANDGUN	HOSE	WT.
SK-61-12V	60	Skid	2.1	60	Pistol Grip	25'	130#
SK-61-4R	60	Skid	6.0	120	Pistol Grip	25'	155#
ATVTS-60-12V	60	Trailer	3.8	45	Pistol Grip	25'	200#
ATVTS-60-4R	60	Trailer	6.0	120	Pistol Grip	25'	220#

SPRAY BOOMS	SPRAY WIDTH	BOOM TYPE	NOZZLE TYPE	NO. OF NOZZLES	NOZZLE SPACING	WT.
BK-2-61	80"	Rigid	Flood	2	40"	15#
BK-4-61	100"	Folding	Fan	5	20"	18#
BK-7-61	140"	Folding	Fan	7	20"	20#

LG 3-PT. SERIES 55 & 110 GAL. CAPACITY



- High quality polyethylene tanks
- Cat. 1, 3-point hitch
- Pressure gauge and relief valve
- 3-Way boom control valve on 110 gallon
- Standard or XL Silvercast pumps
- Optional 21' & 28' booms for 110 gal.
- Quick coupler adapter to PTO connection
- Optional handgun and hose kit

MODELS	GALLONS	G.P.M.	PSI	PUMP	WT.
LG-55-3PT	55	9.76	300	Cast iron or silvercast	130#
LG-110-3PT	110	9.76	300	Cast iron or silvercast	190#

SPRAY BOOMS	SPRAY WIDTH	BOOM TYPE	NOZZLE TYPE	NO. OF NOZZLES	NOZZLE SPACING	WT.
BK-70A	140"	Folding	Fan	7	20"	20#
257-6	21'	Folding	Fan	13	20"	82#
257-8	28'	Folding	Fan	17	20"	96#

- Low position on tank insures excellent self-priming capabilities
- Demand switch only operates when liquid flow is required
- Pump and motor stop instantly when discharge is closed
- Diaphragm design eliminates troublesome shaft seals
- Ball bearing drive, Santoprene diaphragms & viton seals assure longer pump life

HIGH-FLO PUMPS SPOT, UTILITY, & TRAILER MODELS

**NOW WITH AN
INTERNAL FAN
FOR COOLING**



Both Models Feature High Quality Piston Diaphragm Pumps

50 Gallon Trailer



Get versatile, economical performance from our quality line of **Compact 50 Gallon Sprayers**. Available in Trailer, 3-Point Hitch or Skid-mounted. The units are powered by either Honda, B/S or PTO driven. Special diaphragm pump produces high volume pressure and lasts longer.

Trailer sprayer designed to be pulled by ATV's. The 3-Point Hitch sprayer fits on small garden tractors. Skid unit fits nicely in the back of small pick-up trucks.

50 Gallon 3-Point

FEATURES & SPECIFICATIONS:

TANK: 50 gallon capacity polyethylene with sump, hatch cover and strainer screen

PUMP: Diaphragm pump produces 5.3 GPM with pressures up to 275 PSI

POWER: Honda 2.2 HP, Briggs & Stratton 3 HP or PTO driven

FRAMES: Steel with zinc plating to prevent rust

AGITATION: Jet high pressure - In tank

OTHER STANDARD EQUIPMENT: Adjustable control valve, line strainer and pressure gauge

OPTIONS: 5 and 10 foot sprayer boom - Handgun and 25 feet of hose



SPECIFICATIONS:

MODELS:	TRAILER UNIT*	SKID UNIT	3-POINT UNIT
Width:	36"	24"	36"
Length:	75"	52"	26"
Height:	35"	32"	31"

* Trailer sprayer comes with 18 x 9.50 - 8 ply floatation tires

"GC" Series

You will achieve total versatility and economical performance from our two series of 3-Point Hitch Sprayers. The rear rails on both series allows for easy mounting of a number of bolt-on attachments such as a vertical boom, horizontal booms, hose reels, and handguns. The sprayers feature reinforced polyethylene tanks suspended from a tubular steel frame to isolate the tanks. Also featured are piston diaphragm pumps and a hand wash tank for convenience and safety.

FEATURES:

- Category I, 3-point hitch
- Polyethylene tanks with liquid level gauge
- Tank capacities of 100 & 150 gallon
- Three piston diaphragm pumps produce up to 11 G.P.M. at 580 PSI
- Pressure regulator valve and gauge
- Large suction filter
- High pressure jet agitation
- Separate clean water tank for safety
- Rear mounted rails for mounting booms



150 GALLON SHOWN WITH FOLDING BOOM

SPECIFICATIONS:

MODEL NO.	TANK CAP.	PUMP GPM / PSI	WIDTH	HEIGHT	DEPTH	WT.
GC400	100 Gal.	11 / 580	44"	44"	36"	190#
GC600	150 Gal.	11 / 580	44"	48"	36"	225#

"GDL" Series



FEATURES:

- Category I, 3-point hitch on 50 gallon, Category I & II hitch on 100, 150, & 200 gallon
- Tanks are made of reinforced polyethylene with smooth lines that are gentle to plants
- High pressure 3 piston diaphragm pump
- Pressure regulator valve with manual controls
- Clean water 12 gallon tank for flushing chemical residue, 6 gallon on 50 gallon sprayer
- High pressure jet agitation
- Clean water 4 gallon tank for hand washing

SPECIFICATIONS:

MODEL NO.	TANK CAPACITY	PUMP GPM / PSI	WIDTH	HEIGHT	LENGTH	WEIGHT
GDL200	50 Gallon	11 / 580	38"	38"	20"	230#
GDL400	100 Gallon	14 / 580	48"	45"	30"	250#
GDL600	150 Gallon	14 / 580	48"	52"	30"	290#
GDL800	200 Gallon	14 / 580	61"	55"	39"	350#

High Pressure Pump For High Gun Spraying
Low Pressure Pump For Boom Spraying

Boom / Handgun

We feature two different types of pumps for two types of applications. The 200 gallon sprayers have a high volume and high pressure pump, best for multiple handgun use. Also, we are introducing a high volume, low pressure 200 gallon sprayer with new 20 and 28 foot hydraulic booms. The simple design makes the sprayer easy to use. Recessed pump location allows close coupling to tractor and reduces angle of driveshaft. Tank is suspended from a heavy tubular frame to isolate it from vibration and stress. All these features, plus many more, add up to high value sprayers.

FEATURES:

- Fiberglass tank with hatch and strainer basket
- Mechanical agitation with stainless steel propeller and shaft
- Diaphragm pump produces 23 GPM @ 700 PSI or centrifugal pump 34 GPM @ 100 PSI
- Cat. 1 or 2, 3-pt. hitch 540 R.P.M., PTO driven
- Sight gauges in tank and tubing
- Controls are reachable from tractor seat allowing operator to switch liquid from off to right or left spraying

**MODEL
GN200D-LP
w/ 28' HYD.
BOOM SHOWN**



SPECIFICATIONS:

MODEL NO.	TANK CAP.	PUMP TYPE	PUMP GPM	PUMP PRESSURE	WT.
GN200D-23	200 Gal.	Diaphragm	23	700	450#
GN200D-LP	200 Gal.	Centrifugal	34	100	480#

All Purpose 200 Gallon Trailer/Skid Sprayers



FEATURES:

- Available in trailer or skid mount
- 8 H.P. Honda engine
- Reinforced polyethylene tank with two hatches
- Screw type, pin away tongue jack
- 3 Piston diaphragm pump, produces 14 GPM at max. pressure
- Pressure regulator w/manual controls reachable from seat
- Trailer tire size is 20 x 10.00- 6 ply
- Unique rear rail system for mounting many spraying attachments

SPECIFICATIONS:

MODEL NO.	TYPE	WIDTH	LENGTH	HEIGHT	WT.
GPE800	Trailer	54"	102"	48"	490#
GSE800	Skid	35"	80"	36"	360#

Our new sprayers offer the latest design in an **All Purpose Sprayer**. The low profile polyethylene tank has a full length stainless steel agitation system and a large hatch with shower head to easily put wettable powder into suspension. An additional water filling hatch is included to keep chemicals from being splashed while filling. The sprayer can be used as a horizontal boom, row line boom, and/or hose/reel/handgun sprayer. The applications for these sprayers are endless - municipalities, golf courses, nurseries, farms, ranches, etc.

- Available options:
 - ~ Horizontal Booms
 - ~ Row Line Booms
 - ~ Hose/Reel/Handgun

Air Blast 3-Point Hitch Sprayers

Our **Compact Air Blast Sprayers** are ideal for small to medium size vineyards, orchards, berries, etc. The sprayers feature reinforced polyethylene tanks with smooth lines that are gentle to the plants. The tanks are suspended from heavy duty tubular steel frames to isolate it from vibration and stress. The gearboxes have a neutral position which shuts off the fan during handgun or boom work. The sprayers are easy to operate and have all the features required for easy maintenance and long life.

FEATURES:

- ❑ Tanks are made of reinforced polyethylene with smooth lines that are gentle to plants
- ❑ 3 Diaphragm piston pump, 14 GPM @ 580 P.S.I.
- ❑ One speed gearbox with neutral
- ❑ High speed fans with adjustable blades
- ❑ Pressure regulator valve with manual controls
- ❑ Hot galvanized steel fan housing for long life
- ❑ High pressure jet agitation
- ❑ Large suction filter with shut-off valve
- ❑ Stainless steel manifolds with anti-drip nozzles
- ❑ Fan shield to prevent trash pick-up in fan
- ❑ Clean water 12 gallon tank for flushing chemical residue, 6 gallon on 50 gallon sprayer
- ❑ Clean water 4 gallon tank for hand washing



SPECIFICATIONS:

MODEL	A INCH	B INCH	C INCH	WT.
APL200	36"	39"	38"	300#
APL400	46"	48"	45"	375#
APL600	46"	48"	52"	440#

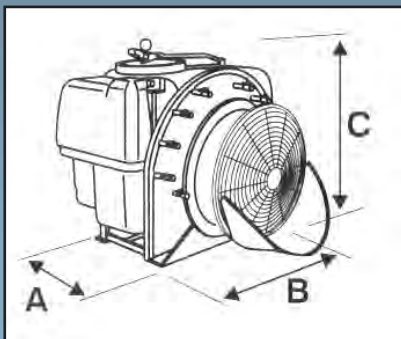

Model - Gal.	Inch	R.P.M.	C.F.M.	No.	HP
APL200 - 50	24"	2100	19200	8	20-25
APL400 - 100	28"	2100	25000	10	30-40
APL600 - 150	28"	2100	25000	10	40-50

Air Blast Trailer Sprayers



**300 GALLON MODEL
SHOWN WITH OPTIONAL
ELECTRO VALVE CONTROLS**

These Air Blast Sprayers feature stainless steel tanks, with mechanical agitation, also stainless steel shaft and propellers. Both models have modern front shields to protect the pump and tank from damage when spraying in confined areas.

Added to the tank features are high pressure piston diaphragm pumps, two speed transmissions with neutral, heavy steel frames, adjustable pitch fans, shower heads in the strainer basket to dissolve wettable powders; which add up to state of the art sprayers to fit your spraying requirements.

FEATURES:

- 300 & 500 Gallon stainless steel tanks
- Mechanical agitation system with stainless steel shaft and propellers
- Fans have adjustable pitch blades and rubber clutch
- Modern dome front shield
- Wheels are adjustable up or down; front or rear
- Fold-up steps on both sides of sprayers
- Steel rear bumper
- Large pressure gauge
- Two speed gearbox with neutral
- Piston diaphragm pumps
- Frames are powder coated black
- Shower head in strainer basket to put wettable powders into solution
- Stainless steel manifolds with anti-drip nozzles
- Adjustable clevis drawbar
- Constant velocity P.T.O. shaft
- Liquid controls (300 Gallon)
- Electro valve controls (500 Gallon)

OPTIONS:

- ~ Electro valve controls (300 Gallon)
- ~ Sharp angle turning hitch in lieu of clevis drawbar
- ~ Flip over nozzles in lieu of single nozzles
- ~ 11L x 15 tires in lieu of 9.5L x 15 (300 Gallon)
- ~ 12.5 x 15 tires in lieu of 11L x 15 (500 Gallon)

SPECIFICATIONS:

MODEL NO.	TANK CAP.	FAN DIA.	FAN C.F.M.	H.P. REQ'D	PUMP SPECS	TIRES	MIN. WIDTH	HEIGHT	LENGTH	WT.
ATSS1200	300 Gal.	28"	32,000	55 H.P.	21.4 GPM @725 PSI	9.5L x 15 - 8 Ply	57"	57"	10' - 3"	1500#
ATSS2000	500 Gal.	32"	40,000	75 H.P.	30.7 GPM @725PSI	11L x 15 - 8 Ply	63"	60"	11' - 6"	2155#

Venturi Air 3-Point Hitch Models

FEATURES:

- ❑ High performance, precision balanced all steel, centrifugal fan
- ❑ Special molded polyethylene fan housing
- ❑ Translucent heavy walled polyethylene tank with lid, sump and strainer basket
- ❑ Built-in overrunning clutch to protect the tractor and sprayer drive train
- ❑ Compact, rounded tank design permits traveling through vegetation without damaging it
- ❑ Simple, efficient "Dial-A-Rate", 15 position metering disc
- ❑ Agitation by liquid sparging tube and air from the fan
- ❑ Low pressure spraying system - 15 to 40 PSI spraying pressure means less maintenance for pumps and nozzles
- ❑ Power band fan speed-up is automatically adjusted by spring loaded idler
- ❑ Broad range of Venturi distribution heads that produce 50 micron droplets and are specially designed to match a variety of foliage profiles
- ❑ Capable of application rates of 20 to 200 gallons per acre, depending on row width
- ❑ Reachable controls from tractor seat, allows operator to switch liquid from off to right, left or both sides spraying
- ❑ Built-in 6 gallon fresh water safety tank



These unique **Venturi Air Sprayers** feature the latest technology in low volume spraying. Thus, growers achieve the following benefits: spray atomization of droplets are smaller and more uniform, less fill-ups, even distribution of concentrated spray, complete foliage coverage, better product utilization, less chemical waste and soil/water contamination.

SPECIFICATIONS:

MODELS:	P42N1-300-G	P42N1-400-G	P45N1-400-G	P50N1-400-G	P50N1-600-G	P50S1-600-G	P55S1-600-G
Tank Capacity:	75 Gallon	100 Gallon	100 Gallon	100 Gallon	150 Gallon	150 Gallon	150 Gallon
Diameter of Fan:	17 3/4"	17 3/4"	17 3/4"	19 3/4"	19 3/4"	19 3/4"	21 3/4"
Fan (R.P.M.):	3900	3900	4500	4000	4000	4320	3720
Volume of Air:	2350	2350	3180	4444	4444	4875	8240
Air Speed (MPH*):	400	400	420	390	390	405	380
Tractor PTO Min. **:	18 HP	18 HP	32 HP	45 HP	45 HP	52 HP	60 HP
Controls:	Liquid	Liquid	Liquid	Liquid	Liquid	Liquid	Electro
Sprayer Width:	38"	44"	44"	44"	57"	57"	57"
Sprayer Height:	46"	46"	46"	46"	48"	48"	48"
Sprayer Length:	54"	54"	54"	57"	57"	57"	58"
Weight w/o Distributor:	400#	440#	455#	510#	540#	540#	550#

* Air speed will vary depending on the type of distribution head used.

** Horsepower is minimum requirement for average operating conditions. Soft soil and hilly conditions will require more horsepower than shown.

With Short Turning Radius Hitch - Designed So The Driveshaft Is Always Straight In Line

Venturi Air Sprayer

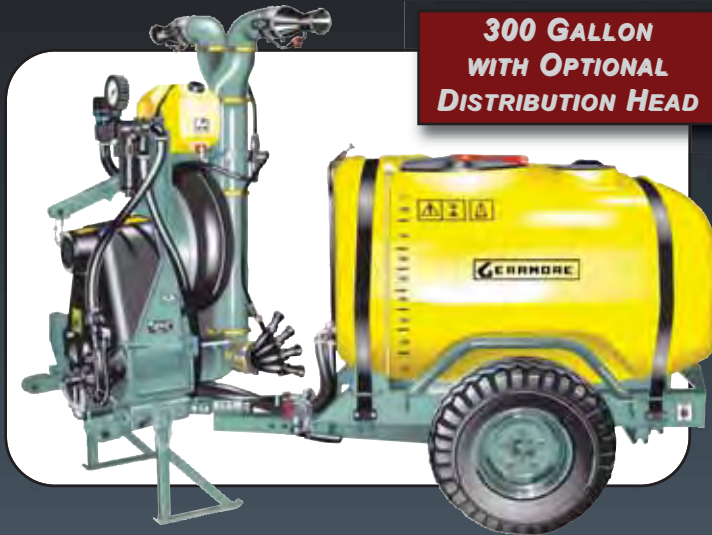

300 GALLON WITH OPTIONAL DISTRIBUTION HEAD

The **Venturi Trailer Sprayer** is now available with a short turning radius design. The fan and distribution head is 3-point hitch mounted. The trailer assembly is attached to the fan assembly with a heavy duty double knuckle joint. The sprayer can "turn on a dime" with no stress or damage as the drive system is always straight.

This trailer sprayer is the perfect unit for narrow rows and short head rows.

FEATURES:

- Turns as sharp as your tractor
- Parking stands for 3-point and trailer assemblies
- Double knuckle turning hitch
- High performance, precision balanced all steel, front mounted centrifugal fan
- Special molded polyethylene fan housing
- Translucent heavy walled polyethylene tank with hinged lid, sump, strainer basket and shower head
- Dual tank lids for safety, one for water and one for adding chemicals
- Compact, rounded tank design permits traveling through vegetation without damaging it
- Adjustable tread width - Facilitates matching sprayer tread with tractor tread
- Simple efficient "Dial-A-Rate", 15 position metering disc
- Centrifugal pump - 37 G.P.M.
- Dual agitation systems, liquid and air
- Low pressure spraying system - 15 to 40 PSI spraying pressure means less maintenance for pumps and nozzles
- Built-in overrunning clutch to protect the tractor and sprayer drive train
- Power band fan speed-up is automatically adjusted by spring loaded idler
- Broad range of Venturi distribution heads that produce 50 micron droplets and are specially designed to match a variety of foliage profiles
- Capable of application rates of 20 to 300 gallons per acre, depending on row width
- Reachable controls from tractor seat, allows operator to switch liquid to right, left or both sides spraying
- 8 Gallon fresh water safety tank
- Large liquid filled pressure gauge
- Pressure control valve and large main strainer

SPECIFICATIONS:

MODELS:	L50N1-800	L50S2-1200		L50N1-800	L50S2-1200	
Tank Capacity (gallon):	200 Gallon	300 Gallon		No. of Pumps:	1	2
Diameter of Fan:	19 3/4"	19 3/4"		Tire Size:	9.5Lx15-8 Ply	11Lx15-8 Ply
Fan (R.P.M.):	4000	4320		Sprayer Width (Min.):	43"	54"
Volume of Air (CFM):	4444	5000		Sprayer Height:	66"	66"
Air Speed (MPH*):	391	420		Sprayer Length:	9'	9'
Tractor PTO Min. **:	48 HP	52 HP		Weight w/o Distributor:	855#	960#
Controls:	Electric	Electric				

* Air speed will vary depending on the type of distribution head used.

** Horsepower is minimum requirement for average operating conditions. Soft soil and hilly conditions will require more horsepower than shown.

Venturi Air - Trailer Models

These unique **Venturi Air Sprayers** feature the latest technology in low volume spraying. Thus, growers achieve the following benefits: spray atomization of droplets are smaller and more uniform, less fill-ups, even distribution of concentrated spray, complete foliage coverage, better product utilization, less chemical waste and soil/water contamination.

FEATURES:

- High performance, precision balanced all steel, front mounted, centrifugal fan
- Special molded polyethylene fan housing
- Unique polyethylene belly mounted air tubing to the distributor heads
- Translucent heavy walled polyethylene tank with hinged lid, sump, strainer basket and shower head
- Dual tank lids for safety, one for water and one for adding chemicals
- Compact, rounded tank design permits traveling through vegetation without damaging it
- Heavy tubular steel frame
- Adjustable axle position, facilitates positioning axle closer/farther from tractor for lighter or heavier tongue weight or shorter turning circle
- Adjustable tread width, facilitates matching sprayer tread with tractor tread
- Tongue with clevis hitch has length adjustment
- Simple, efficient "Dial-A-Rate", 15 position metering disc
- Dual centrifugal pumps - 37 GPM for spraying and 37 GPM for agitation



- Dual agitation systems, liquid and air
- Low pressure spraying system - 15 to 40 PSI spraying pressure means less maintenance for pumps and nozzles
- Built-in overrunning clutch to protect the tractor and sprayer drive train
- Power band fan speed-up is automatically adjusted by spring loaded idler
- Broad range of Venturi distribution heads that produce 50 micron droplets and are specially designed to match a variety of foliage profiles
- Capable of application rates of 20 to 300 gallons per acre, depending on row width
- Electro-valve controls to allow operator to switch liquid from off to right, left, or both sides spraying
- Built-in 8 gallon fresh water safety tank

MODELS:	T45N1-800	T50S2-1200	T55S2-1200	T55S2-1500	T55S2-2000	T55E2-2000
Tank Capacity:	200 Gallon	300 Gallon	300 Gallon	400 Gallon	500 Gallon	500 Gallon
Diameter of Fan:	17 3/4"	19 3/4"	21 3/4"	21 3/4"	21 3/4"	21 3/4"
Fan (R.P.M.):	4500	4320	3720	3720	3720	3900
Volume of Air:	3180	5000	8240	8240	8240	9123
Air Speed (MPH):	420	421	380	380	380	402
Tractor PTO Min:	36 HP	52 HP	60 HP	60 HP	60 HP	74 HP
Controls:	Electric	Electric	Electric	Electric	Electric	Electric
No. of Pumps:	1	2	2	2	2	2
Tire Size:	9.5Lx15-8 Ply	11Lx15-8 Ply	11Lx15-8 Ply	12.5Lx15-10 Ply	12.5Lx15-10 Ply	12.5Lx15-10 Ply
Sprayer Minimum Width:	48"	55"	55"	64"	71"	71"
Sprayer Height:	52"	54"	54"	59"	66"	66"
Sprayer Length:	10' - 5"	11' - 8"	12'	14'	14'	14'
Weight w/o Distributor:	910#	970#	1020#	1360#	1555#	1555#

Sprayers With Wrap-A-Round Booms



**BOOM MODEL
TS56MC55D12 ON 500
GALLON SPRAYER SHOWN**

Now available is a complete new series of high strength wrap-around spray booms. The booms feature extra strong framing with heavier support tubings to the sprayer frame. The five hydraulic cylinders give total control on height adjustment, swing up for in row obstructions, and fold away for transport. The width adjustment is manual, as the spread is rarely changed.

These booms are available to spray two complete rows or two complete rows and two half rows. Boom controls are available in manual or optional electro hydraulic controls. The booms are designed to fit the popular 300 and 500 gallon Venturi Air Sprayer.

FEATURES:

- Sprayer features same as page 80
- Booms swing hydraulically from operational to closed position
- Booms fold forward for transport and lock
- Height adjustment is hydraulic
- Boom bottoms can be fitted with single or double 4 + 4 nozzles
- Boom tops can be fitted with 4 + 4 nozzles, cannons, or neither head

SPECIFICATIONS:

Boom Model No.	Sprayer Model	Gals.	No. of Rows	No. of Nozzle Assy	Row Space	Max. Crop Height	Boom Clearance	Nozzle Positions	Type of Bottom Nozzles	Type of Top Nozzles
TS56MB55M12	T55S2-1200	300	2 - Full 2 - Half	6	7.5' - 10'	7 ft.	8 1/2 ft.	Bottom Only	4 Outlet Head	None
TS56MC55D12	T55S2-2000	500	2 - Full 2 - Half	6	9.5' - 13'	8 ft.	9 1/2 ft.	Bottom Only	4 Outlet Head	None
TS54M4CC55D12	T55E2-2000	500	2 - Full	8	9.5' - 13'	8 ft.	9 1/2 ft.	Top & Bottom	4 Outlet Head	Cannons

Over 30 Separate Distribution Heads -
Customize To Fit Your Foliage Profile

Distribution Heads

We also customize special distribution heads on request

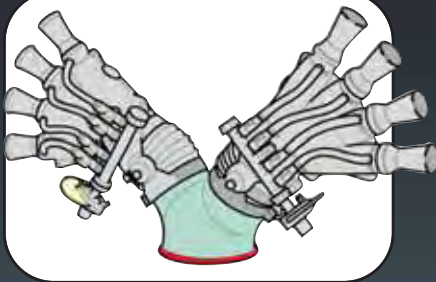

VINEYARD HEAD
8 NOZZLES

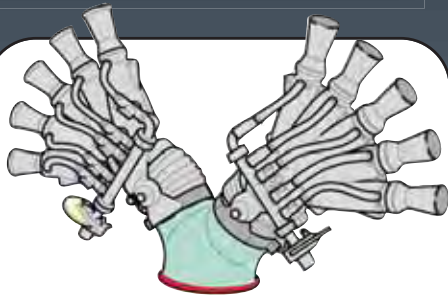

VINEYARD HEAD
10 NOZZLES

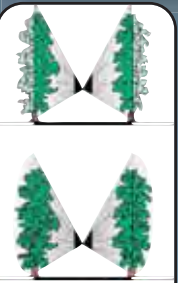

ORCHARD HEAD
2 VENT

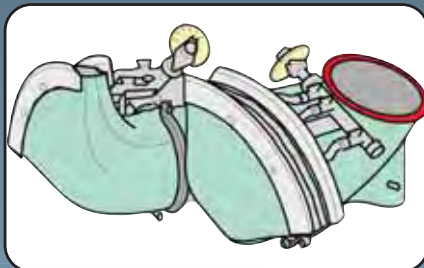

**HORIZONTAL
CANNON**
HIGH POSITION

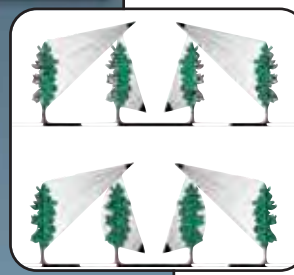
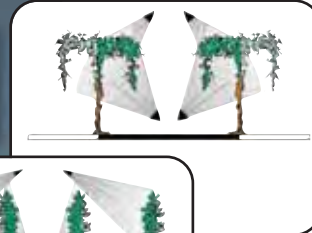
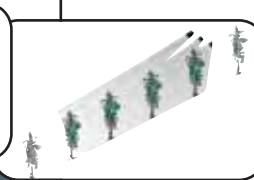

TREE CANNON
HIGH POSITION

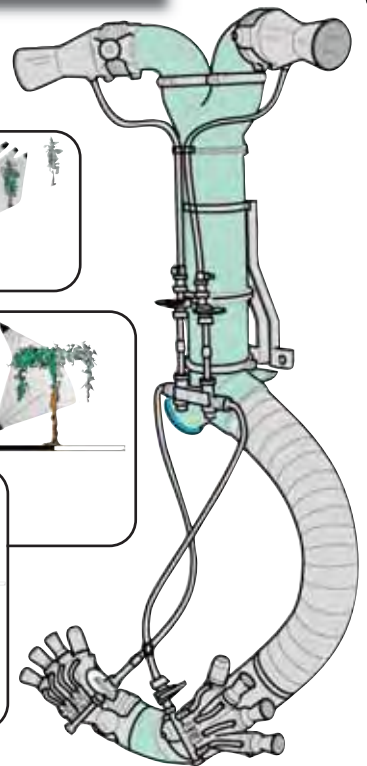

**2 UPPER CANNONS &
4 + 4 BOTTOM HEADS**

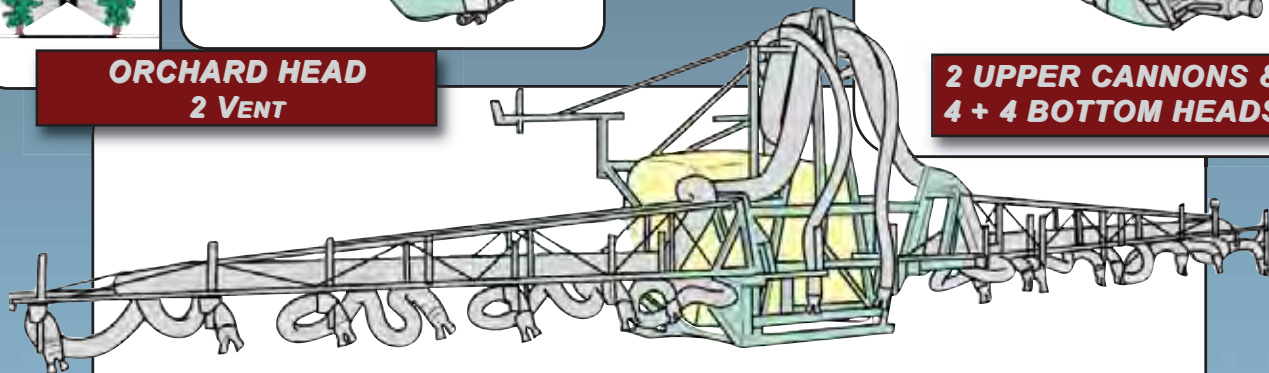

AIR BOOM
40 FOOT

Venturi Air Boom Sprayers

**27' BOOM
SPRAYER SHOWN**



**40' BOOM
SPRAYER SHOWN**



- TANK:** Translucent polyethylene 150 gallon with hatch and strainer basket
- AGITATION:** Adjustable liquid bypass, and air from fan when required
- DRIVE:** 540 RPM P.T.O. driven with belt drive to fan and pump with overrunning clutch
- NOZZLES:** "No drip" system on each nozzle and individual liquid shut-off by hand, replaceable stainless steel discs and screens
- CONTROLS:** Reachable from tractor seat allowing operator to switch liquid from off to right or left
- FILTRATION SYSTEM:** 3 Stages - at filler, at pump, and at nozzles
- FAN:** Centrifugal type with PVC housing
- PUMP:** Centrifugal with maximum 37 GPM
- SIGHT GAUGES:** In tank and tubing
- PRESSURE GAUGE:** 0 to 80 P.S.I. in liquid case to reduce vibration and extend life

SPECIFICATIONS:

MODELS:	P50S-600-27	P55S1-600-40S	P55S1-600-40
Boom Width:	27'	40'	40'
Rows:	8 Row	7 Row	12 Row
No. of Nozzles:	2+2 = 32	2+3+2 = 49	2+2 = 48
Boom Design:	Steel Tubing	Framed Poly Air Tubing	Framed Poly Air Tubing
Tank Capacity:	150 Gal.	150 Gal.	150 Gal.
Diameter of Fan:	19.75"	21.75"	21.75"
Fan (RPM):	4320	3720	3720
Volume of Air (CFM):	4875	8240	8240
Air Speed at Foliage:	10-50 MPH	10-50 MPH	10-50 MPH
Controls:	Liquid	Electro-Valve	Electro-Valve
Minimum Tractor HP:	52	60	60
Sprayer Weight:	1230#	1800#	1800#

FEATURES:

- ❑ Air velocity of 200 MPH at nozzle breaks down spray to fog size (50 microns) droplets which penetrate in and around all areas of each plant
- ❑ Air movement allows chemical to completely cover vegetation, especially the underside of leaves
- ❑ Volume as low as 5 gallons per acre results in fewer refilling stops and more acres covered per day
- ❑ Spray drift is reduced by 50% to 75%.
- ❑ Boom has breakaway and hydraulic fold away features to prevent damage and for transport
- ❑ Boom raises and lowers hydraulically for different crop heights, independent of the sprayer
- ❑ Boom nozzles are completely adjustable in width and angle for maximum coverage
- ❑ Chemicals only come in contact with plastic, rubber, and stainless steel parts

3-Point Seeder / Spreaders



Our 3-point hitch spreaders feature a strong, corrosion proof PVC hopper. These spinner units have double levers and stainless steel slides which allow for spreading at 180° or 90° to the right or left. They are ideal for even spreading fertilizer, seed, salt, and other flowable materials.

FEATURES:

- Cat. 1, 3-point hitch, 540 PTO
- Corrosion proof PVC hopper
- Stainless steel spreading disc with 4 stainless steel fins
- Steel oil tight gearbox with grease zerck
- Extended handle for engaging and disengaging
- Choice of 3 spread patterns: full rear, left or right side
- Effective spreading width from 20 to 46 feet.
- Built in rear hitch
- Adjustable uniform rates from 20 to 900 lbs./acre

OPTIONS:

- Larger extended hopper agitator
- One and two row band spreader attachments

SPECIFICATIONS:

MODEL NO.	CAPACITY		OVERALL HEIGHT	WT.
	LBS.	CU. FT.		
PL180	480 lbs.	5.8 cu. ft.	36"	120#
PL300	765 lbs.	9.2 cu. ft.	42"	130#
PL500	1000 lbs.	12.3 cu. ft.	45"	140#

Trailer Mounted Seeder / Spreaders

Our Seeder/Spreader is a self contained, towable implement that can be operated by almost any vehicle. This unit has a ground driven, cast iron, oil bath gearbox that can be disengaged when transporting. It is ideal for spreading seed, fertilizer, sand, and salt. The large 16" diameter x 6.5" wide tires make this a "Turf Friendly" implement. This spreader is a handy tool for farmers, landscapers, and homeowners.

FEATURES:

- Ground wheel driven
- Corrosion proof PVC hopper
- Cast iron, oil bath gearbox
- Gearbox disengages for transport
- Stainless steel spreading disc with 4 stainless steel fins
- Extended handle for engaging and disengaging material flow
- 16 x 6.5-8 Ply turf tires
- 1 7/8" Ball hitch
- Spreading widths from 20' to 46'
- 3 Spread patterns : full rear, left or right side

OPTIONS:

- Larger extended agitator



SPECIFICATIONS:

MODEL NO.	CAPACITY		HT.	WIDTH	DEPTH	WT.
	LBS.	CU. FT.				
PTP180-P	480 lbs.	5.8 cu. ft.	51"	41"	59"	175#
PTP300-P	765 lbs.	9.2 cu. ft.	51"	41"	59"	185#

Single Spinner

Our high capacity 3-point spreader features a stainless steel, single spinner disc with 6 stainless steel vanes. Spreaders have a heavy duty stamped and ribbed frame. All metal hoppers and frames have special phosphated undercoat, then epoxy powder painted and baked at 300 degrees to insure long life. The spreader can be set at 180°, 90° right, or 90° left spreading pattern.



FEATURES:

- Cat. II 3-point hitch
- Low loading height
- Sturdy stamped and ribbed steel frame
- Opening levers system
- 6 Fins spreading disc for even spreading width

SPECIFICATIONS:

MODEL NO.	CAPACITY		HT.	WIDTH	DEPTH	WT.
	LBS.	CU. FT.				
RT-800	1700 lbs.	28 cu. ft.	40"	59"	53"	345#

Double Spinner



**SHOWN WITH OPTIONAL
2 ROW BAND SPREADER
ATTACHMENT**

Our 2200 pound capacity 3-point spreader features dual stainless steel spinner discs, which are extremely accurate with only 6.7% variance across the spread pattern. The spreaders are supplied with manual lever controls with optional hydraulic controls when the tractor has a cab. The usual special painting system insures long life.

FEATURES:

- Cat. II 3-point hitch
- Lever opening system or hydraulic system
- Stainless steel construction
- Two stainless steel discs with 3 vanes each
- Two models available

SPECIFICATIONS:

MODEL NO.	CAPACITY		HT.	WIDTH	DEPTH	WT.
	LBS.	CU. FT.				
RE-1000	2200 lbs.	35 cu. ft.	45"	59"	53"	450#

Pull Type Spinner Spreader

Our Seeder/Spreader is a self contained, towable implement that can be operated by almost any vehicle. This unit has a ground driven, cast iron, oil bath gearbox that can be disengaged when transporting. It is ideal for spreading seed, fertilizer, sand, and salt. The large 20" diameter x 10 wide tires make this a "Turf Friendly" implement. The spreader features a cable control that allows the operator to adjust spread rate and turn the spreader on and off from the vehicle seat. This is a popular, low cost spreader for golf courses, parks, sport fields, and turf farms.



FEATURES:

- Pull type, ground wheel driven
- Gearbox lever to disengage drive during transport
- Remote cable control from vehicle
- Agitators to prevent bridging
- Seamless steel hopper, with chemical resistant powder coated paint
- Spreads up to 52 feet
- Spreading disc with 6 zinc plated fins
- 20 x 10:00 - 8 tires
- Full width or spreading to one side
- Height adjustment on 2" ball hitch & clevis hitch

OPTIONS:

- ~ Clevis type hitch
- ~ Secondary chain agitator
- ~ Canvas hopper cover
- ~ Cable control mounting bracket
- ~ Remote hopper vibrator



To insure easy clean-out, the flow openings are in the bottom of the hopper.

SPECIFICATIONS:

MODEL NUMBER	CAPACITY		SPREADING WIDTH	MACHINE			WEIGHT
	LBS.	CU. FT.		HEIGHT	WIDTH	DEPTH	
PTB560	1070 lb.s	14.2 cu. ft.	Max. 52'	51"	65"	96"	310#

To Achieve The Most Accurate Placement Of Fertilizers And Seeds



MODEL PDC400

Our new line of pendulum spreaders feature an advanced mechanism with regulating key which allows for quickly setting the spread pattern. Other features are exact rate/spread control, quick change spouts, low filling heights, and easy maintenance. The model PDC400 has a molded plastic hopper, all other models have formed fiberglass hoppers. The spreading width with the standard spout is 20 to 46 feet. A large variety of spouts are available for standard broadcast, narrow row and wide row vineyards and orchards. Spreaders can also be set for band and one sided banding. Hopper capacities from 925 to 2000 pounds.

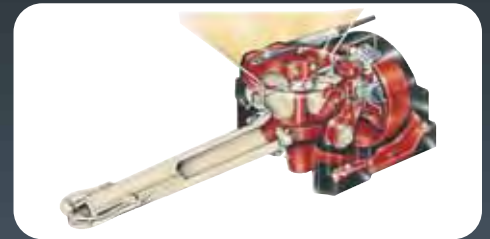

MODEL PDV500



304.101 Spout
Full field spreading
13 to 26 Feet



304.102 Spout
Narrow spreading
3 to 14 Feet



304.103 Spout
Vineyard spreading
6 to 13 Feet



304.105 Spout
Vineyard / Orchard
6 to 33 Feet

The above spouts fit all models

SPECIFICATIONS:

MODEL NO.	HITCH CATEGORY	CAPACITY		OVERALL WIDTH	OVERALL HEIGHT	WT.
		LBS.	CU. FT.			
PDC400	Cat. 1	925 lbs.	13.6 cu. ft.	46"	47"	225#
PDV500	Cat. 1 & 2	1155 lbs.	17 cu. ft.	54"	36"	290#
PDV600	Cat. 1& 2	1450 lbs.	20.5 cu. ft.	54"	40"	315#
PDHV800	Cat. 2	2000 lbs.	32 cu. ft.	74"	40"	375#



Manure Spreaders

Many Special Optional Features Are Available

Operating Levers

Our soft handle grips and easy action design make our levers truly easy to engage.

Thick-Skin Urethane Lining

Prevents corrosion and adds years of life to the spreader box; lining comes with a 10-year pro-rated warranty against rust-through. (Optional for most models)

Poly Floor

Made from recycled, high-density plastic so it will never rust or rot and comes with a 20-year warranty. (Not included with all models)

End Gate

A great help containing loads during transport, and for shielding the operator when spreading. (Not included with all models)

Adjustable Hitch

Conveniently adjusts to the height of the towing vehicle, making the process safe and easy, even when fully loaded. (Not included with all models)

Adjustable Dolly Wheel/Jack

Provides easy, hand maneuvering in and around the barn. Allows the spreader to rest in level position when not hooked-up for towing. (Not included with all models)

Beaters

Expertly designed to handle the messiest of loads, even pen packed manure.

Safety Bar

An important safety feature that minimizes the potential for injury or damage.



Whether you have one horse or twenty, Millcreek makes a spreader that's just right for you. Every detail is engineered to save time and protect against breakdowns. From the heavy duty, **all-steel construction** to the top **quality powder coating, durable linkage and beater systems**, you can be sure that your Millcreek spreader was built to last. Convenient, time saving options - including the adjustable **dolly-wheel/jack** and the **manual endgate** - further enhance your investment. We're sure that your Millcreek spreader will quickly become the most-valued piece of equipment in your stable!



SPECIFICATIONS:



MODEL:	22	27	37	57	77	97
Number of Horses:	1 - 2	1 - 4	4 - 6	5 - 10	11 - 20	20 +
Capacity, cu. ft./m ³						
Struck:	13 cu. ft.	16 ft. ³ /.45m ³	22 ft. ³ /.62m ³	30 ft. ³ /.85m ³	39 ft. ³ /1.1m ³	58 ft. ³ /1.6m ³
Heaped (ASAE S324.1 Std):	16.2 cu. ft.	28 ft. ³ /.79m ³	37.3 ft. ³ /1.06m ³	56 ft. ³ /1.6m ³	72 ft. ³ /2m ³	109 ft. ³ /3.1m ³
Body Length:	60"	72" / 183cm	96" / 244cm	89.5" / 227cm	114" / 290cm	114" / 290cm
Body Width:	24"	28" / 71cm	28" / 71cm	37" / 94cm	37" / 94cm	55" / 140cm
Body Flare Width:	24"	34" / 86cm	34" / 86cm	44.5" / 113cm	44.5" / 113cm	62.5" / 159cm
Body Height:	16.5"	15" / 38cm	15" / 38cm	17.5" / 45cm	17.5" / 45cm	17.5" / 45cm
Overall Length:	98"	9'3" / 2.8m	11'3" / 3.4m	11'6" / 3.5m	13'6" / 4.1m	13'6" / 4.1m
Overall Width:	42"	46.5" / 118cm	46.5" / 118cm	58" / 147cm	58" / 147cm	79" / 201cm
Overall Height:	26.5"	26.5" / 67cm	26.5" / 67cm	34" / 86cm	34" / 86cm	39" / 99cm
Loading Height:	26.5"	26.5" / 67cm	26.5" / 67cm	34" / 86cm	34" / 86cm	39" / 99cm
Construction:	All Steel	All Steel, with Poly Floor ¹	All Steel, with Poly Floor	All Steel, with Poly Floor	All Steel, with Poly Floor	All Steel, with Poly Floor
Body Lining (sides):	Steel	Thick Skin Urethane ²	Thick Skin Urethane ²	Thick Skin Urethane ²	Thick Skin Urethane ²	Thick Skin Urethane ²
Body Finish:	Galvanized	Powder Coating	Powder Coating	Powder Coating	Powder Coating	Powder Coating
Front Stabilizer:	None	Dolly Wheel/Jack ²	Dolly Wheel/Jack	Swing-away Jack	Swing-away Jack	Swing-away Jack
Apron chain:	#55 Steel Detachable	T-rod Standard ³	T-rod Standard ³	T-rod Standard	T-rod Standard	T-rod Standard
Wheel Assembly:	4.8" x 4" x 4" Bolt	6" x 12" x 4" Bolt 15cmx30cmx10cm Bolt	6" x 12" x 4" Bolt 15cmx30cmx10cm Bolt	7.6" x 15" x 4" Bolt 19cmx38cmx10cm Bolt	7.6" x 15" x 4" Bolt 19cmx38cmx10cm Bolt	8" x 15" x 6" Bolt 20cmx38cmx15cm Bolt
Beater Drive:	#40 Roller Chain	#RC50 ³	#RC50 ³	PTO: Gearbox Ground Drive #RC50	PTO: Gearbox Ground Drive #RC50	PTO: Gearbox
Weight:	250 lbs.	405# / 184kg	470# / 213kg	660# / 299kg	740# / 336kg	1260# / 572kg
Tractor Size:	10 H.P.	15 HP + Lawn & Garden Tractor or 350cc ATV	18 HP + Lawn & Garden Tractor or 450cc ATV	18 HP + Compact Tractor or 500cc ATV	22 HP + Compact Tractor	25 HP + Standard Tractor

1. Model 27 Steel does not include poly floor; available for a limited time only.

2. Optional with certain models.

We Stand Behind Our Product

MARKETED BY: GEARMORE, INC.

Sweepers

Many More Models Available - Contact Us
For Complete Catalog



Rear Mount

Mounts to rear 3-point of compact and industrial tractors. Mechanical or hydraulic brush drive. Manual and hydraulic angle change 30° left/right available. Sweeps forward and windrows debris outside of rear tires on paved and turf areas. Pulling action cleans thatch without damaging grass. Brush rotation can be reversed for operation backing up. Brush widths from 4 ft. to 8 ft.



Compact Front Mount

Mounts to commercial turf mowers, compact utility tractors and industrial loaders. Available in a hydraulic or mechanical brush drive, with manual or hydraulic angle change 30° left/right. Keep your tractor and sweeper busy all year sweeping snow, dirt, thatch, and leaves. Brush widths from 4 ft. to 8 ft.



Angle Sweeper

Mounts to skid steer loaders and is available for mounting on utility tractor loaders. Hydraulic brush drive, with manual or hydraulic angle change 30° left/right available. Single or dual motor configurations are available. Brush is equipped with a quick change core for easy brush change. Heavy duty design with quick attach mounting. Brush widths from 5 ft. to 8 ft.



Pick-Up Sweeper

The **Standard Pick-up Brooms** clean up in construction, municipal and industrial applications. The 26" diameter brushes come in poly, wire or half of each. Options available are: sprinkler system and gutter brush. The **Cold Planer Special** has special compacted dense wafer brushes the width of the cold planer cut. These wafers do not flex as much as the balance of the brush, thus it cleans out the milled grooves.

Manufactured by:



PALADIN LIGHT CONSTRUCTION

"B" Series

For Compact Tractors 15 to 35 Horsepower

These compact series of tillers are quality constructed units that are built to last. The adjustable skid shoes control the cutting depth while the rear tailboard controls the soil mix. The tiller is equipped with a slip clutch to protect the tiller and tractor. Ideal for preparing seedbeds, renovating pastures, and other tillage uses. The tiller provides uniform mix throughout the cultivated depth.

FEATURES:

- Cat. 1, 3-point hitch
- 7" Approximate tilling depth
- One speed gearbox, 540 RPM
- 80# Heavy duty roller chain
- Slip clutch driveshaft to protect tractor and tiller drive system
- Curved saber style, heat treated, long wearing tines
- 6 Tines mounted on each rotor plate for maximum tilling action
- Tines staggered in scroll design for easy soil penetration
- Side mounted skids for depth control



SPECIFICATIONS:

MODEL NO.	TILLING WIDTH	OVERALL WIDTH	NO. OF TINES	APPROX. H.P.	WT.
B100	40"	44"	30	20 HP	300#
B120	48"	52"	36	25 HP	335#
B140	55"	59"	42	30 HP	370#
B150	60"	64"	42	35 HP	420#

"C" Series

For Compact Tractors 20 to 45 Horsepower

Our "C" Series is the modern replacement to our "L" Series tiller. A number of special features are standard at no added cost, such as; slip clutch, all gear final drive, 6 tines per rotor plate, and heavy A.S.A.E. quick hitch A-frame. Excellent tiller for vegetable growers, landscapers, nurseries, vineyards, and general maintenance operations.

FEATURES:

- Cat. 1, 3-point hitch
- 8" Approximate tilling depth
- One speed gearbox, 540 RPM
- Strong, smooth running, all gear final drive
- Slip clutch driveshaft to protect tractor and tiller drive system
- Curved saber style, heat treated, long wearing tines
- 6 Tines mounted on each rotor plate for maximum tilling action
- Tines staggered in scroll design for easy soil penetration
- Powder coated, baked-on paint to reduce corrosion



SPECIFICATIONS:

MODEL NO.	TILLING WIDTH	OVERALL WIDTH	NO. OF TINES	APPROX. H.P.	WT.
C85	34"	38"	30	20 HP	460#
C105	42"	46"	30	25 HP	485#
C125	50"	54"	36	30 HP	510#
C145	56"	60"	36	35 HP	545#
C165	65"	69"	42	40 HP	590#
C185	72"	76"	48	45 HP	640#

"E" Series

For Tractors 20 to 50 Horsepower

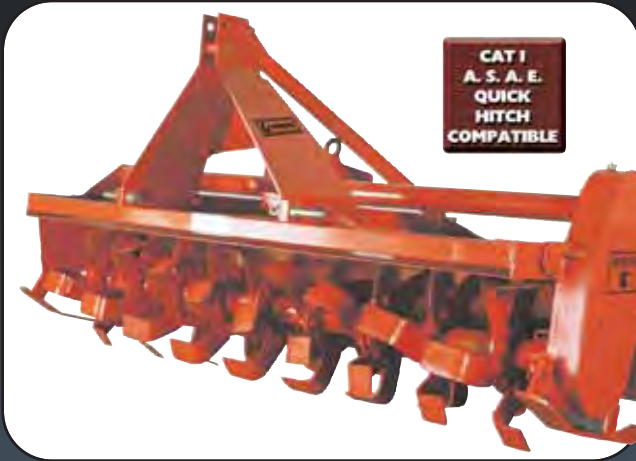

SPECIFICATIONS:

MODEL NO.	TILLING WIDTH	OVERALL WIDTH	NO. OF TINES	APPROX. H.P.	WT.
E48	48"	53"	36	20 to 35 HP	600#
E60	60"	65"	42	25 to 40 HP	690#
E72	72"	77"	54	35 to 50 HP	780#
E84	84"	89"	66	50 to 65 HP	805#

Agricultural & Horticultural

Ideal for preparation of seedbeds, renovation of pastures, orchards, vineyards and mulching-in cover crops and stubble. Provides uniform mixture through-out cultivated depth. Produces loose textured soil that holds moisture, reduces erosion.

Light Industrial

Clears and cleans up land. Eliminates fire hazards by tilling in dried grass. Mixes and blends soils and aggregates for soil stabilization in roads, driveways, parking areas, sidewalks and pathways.

FEATURES:

- Connects to 3-point, Cat. 1, 540 R.P.M. tractors - 7' Cat 1 & 2
- All gear, final drive
- Rugged construction for long life
- Strong, balanced rotorshaft
- Large bearings with protective seals
- Oversize shafts and gears
- Heat treated, long wearing tines
- 6 - L shaped tines per flange
- Well-balanced to eliminate vibration
- Adjustable skids for depth control
- Tailboard with chain adjustments
- Torque tube frame to absorb shock loads
- Driveshaft with slip clutch
- Up to 65 H.P. - E84 only

"N" Series

For Tractors 40 to 70 Horsepower



SPECIFICATIONS:

MODEL NO.	TILLING WIDTH	OVERALL WIDTH	NO. OF TINES	APPROX. H.P.	WT.
N130	51"	60"	30	40 HP	780#
N155	61"	70"	36	50 HP	895#
N180	71"	80"	42	60 HP	970#
N205	81"	90"	48	70 HP	1045#

These medium duty tillers feature a smooth running, all gear drive system. Powered through a heavy 70 horsepower gearbox to an all gear final drive. The tilling action provides a uniform mixture throughout the cultivated depth. Producing loose textured soil that holds moisture and reduces erosion. These are the ideal tillers for farm, vineyard, orchards, landscapers, nurseries, etc.

FEATURES:

- Cat. 1 & 2, 3-point hitch
- 9" Approximate tilling depth
- One speed gearbox, 540 RPM
- Strong, smooth running, all gear final drive
- Slip clutch driveshaft to protect tractor and tiller drive system
- Curved saber style, heat treated, long wearing tines
- Tines staggered in scroll design for easy soil penetration
- Powder coated, baked-on paint to reduce corrosion
- Side mounted skids for depth control

"S" Series

For Tractors 50 to 90 Horsepower

These "S" Series tillers were designed for high usage in agricultural and industrial applications. At a depth of 8 inches, the saber tines produce a uniform mixture of loose, textured soil that holds moisture and reduces erosion. There is no better tool for preparation of seedbeds.

FEATURES:

- Cat. 2 fixed center mount
- 90 HP, 4 speed gearbox
- 4-speeds at 540 RPM
- All gear final drive
- Slip clutch driveshaft
- 6 Tines on each rotor plate - staggered
- Adjustable skids for depth control



OPTIONS:

- Rear Roller, 2 Speed 1000 RPM gears



The S255 tiller is available with a smooth rear roller to bury wood chips and then to slightly compact and smooth out the orchard floor.

SPECIFICATIONS:

MODEL NO.	TILLING WIDTH	OVERALL WIDTH	NO. OF TINES	APPROX. H.P.	WT.
S160	62"	66"	36	50 HP	1190#
S180	71"	75"	42	60 HP	1255#
S205	81"	85"	48	70 HP	1350#
S230	91"	95"	54	80 HP	1430#
S255	102"	106"	60	90 HP	1490#

"T" Series

For Tractors 90 to 160 Horsepower

These "T" Series Tillers were designed for high horsepower tractors to produce a finished seedbed in a single pass. For crops such as vegetables, timing is everything. The basic plow, disc, cultivator tilling operation requires too many passes, wasted fuel, and causes excessive compaction. At a depth of 10 inches, the saber tines produce a uniform mixture of loose, textured soil that holds moisture and reduces erosion. There is no better tool for preparation of seedbeds and incorporating crop residue.

FEATURES:

- Cat. 2, 3-point hitch
- 10" Approximate tilling depth
- 4 Speed gearbox - 2 speeds @ 540 RPM & 2 speeds @ 1000 RPM
- For tractors up to a maximum of 160 HP
- Strong, smooth running, all gear final drive
- Slip clutch driveshaft to protect tractor and tiller drive system
- Curved, saber style heat treated, long wearing tines
- Side mounted skids for depth control



- 6 Tines mounted on each rotor plate for maximum tilling action
- Tines staggered in scroll design for easy soil penetration
- Large, oil bath, long wearing rotor bearings
- Powder coated, baked-on paint to reduce corrosion
- Retractable parking stand

SPECIFICATIONS:

MODEL NO.	TILLING WIDTH	OVERALL WIDTH	NO. OF TINES	APPROX. H.P.	WT.
T230	90"	97"	60	90 to 100 HP	2140#
T280	110"	117"	66	100 to 120 HP	2205#
T305	120"	127"	72	120 to 160 HP	2275#



Topdressers

PTO & Engine Driven Models - Extremely Accurate For Spreading Both Dry & Wet Materials

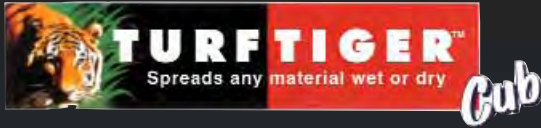

SPECIFICATIONS:

MODEL:	3100 / 3100ED	3200
Capacity, Struck*:	1.0 cu. yd.	1.3 cu. yd.
Capacity, Heaped:	1.8 cu. yd.	2.3 cu. yd.
Capacity, Weight:	3000 lbs.	3750 lbs.
Body Length:	89.5"	114"
Body Width:	37"	37"
Body Height:	17.5"	17.5"
Overall Length:	11'	13'
Overall Width:	70"	70"
Overall Height:	51"	51"
Loading Height:	43"	43"
Construction:	All steel, poly floor	All steel, poly floor
Apron Conveyor:	#67 Steel detachable chain	#67 Steel detachable chain
Tires:	Turf (26.5x14x12, 4-ply) ground pressure, loaded 18 PSI	Turf (26.5x14x12, 4-ply) ground pressure, loaded 19 PSI
Beater Bearings:	Sealed ball bearings	Sealed ball bearings
Beater Drive:	Gearbox / Chain	Gearbox / Chain
Apron Drive:	Gearbox / Chain Reduction	Gearbox / Chain Reduction
Body Finish:	Powder Coating	Powder Coating
Weight (with tires):	1140#	1300#
Tractor Wt. & HP Req'd**:	2000 lbs. & 25 HP & Greater	2250 lbs. & 30 HP & greater

* Struck capacity is level to the top of the side sheets (does NOT include the loading flares)
 ** Tractor weight specifications for LEVEL terrain. For SLOPING terrain, increase tractor weight to 100% of load weight.

Topdress twice as fast without compromising precision. Exclusive Millcreek Saber Tooth technology gives you speed, accuracy and versatility unlike any other topdresser on the market today. There's nothing else as affordable for limited budgets at schools, park and recreation departments, and golf courses. **Turf Tiger Cub** comes in two sizes, 1.8 and 2.3 cubic yard capacity.



SPECIFICATIONS:

MODEL:	4300
Capacity, Struck:	2.2 cu. yd.
Capacity, Heaped:	3.2 cu. yd.
Capacity, Weight:	7500 lbs.
Body Length:	84"
Body Width:	48"
Body Height:	24"
Overall Length:	12' - 8"
Overall Width:	93"
Overall Height:	73"
Loading Height:	65"
Construction:	11 Gauge steel body on heavy steel chassis
Apron Conveyor:	3/16" (thick) Black PVC Belt
Tires:	Turf 41 / 18LL-16.1, 6-ply - ground pressure, loaded 14 PSI
Beater Bearings:	Sealed ball bearings
Beater Drive:	Hydraulic Motor
Apron Drive:	Hydraulic Motor / Chain Reduction
Body Finish:	Powder Coating
Weight (with tires):	2180#
Tractor Weight & HP Req'd:	35 HP & greater, tractor wt. must be at least 50% of gross loaded wt.

Turf Tiger Cub is user friendly and more versatile than any other equipment of its kind thanks to the exclusive Saber Tooth beater. Turf Tiger Cub spreads all kinds of bulk material such as sand/peat topdressing, infield mixes, compost, grass clippings, synthetic material, lime, and wood chips with precision, power and speed.

Listed here are just some of the wet or dry materials you can spread with the Turf Tiger

- ~ Sand/Peat Topdressing
- ~ Soil Amendments
- ~ Wet sand
- ~ Infield Conditioners
- ~ Compost
- ~ Soil Mixtures
- ~ Infield mixes
- ~ Sewage Sludge



The **Turf Tiger** spreads wet or dry material like no other machine. You have total control of spread pattern and thickness of spread by - belt speed, attachment speed, endgate opening and ground speed. You can choose any or all of 3 quick change spreading attachments. The patent pending Saber Tooth attachment is the most effective for wet and dry material, spreading from 8 to 12 feet. The twin spinners are best for light applications, with spreading widths up to 35 feet. The brush attachment provides precision drop spreading 42" wide.

As added pluses, you get the following features as standard equipment:

- Powerful dual hydraulic system operates from tractor system or PTO system
- Rubber coated drive rollers prevent belt slippage
- Self aligning "V-Track" System
- Dual hydraulic controls provide infinite speed adjustments for belt & attachments

**MARKETED BY:
GEARMORE, INC.**

Valve & Bracket Assembly

The valve and valve bracket assemblies are a simple and easy to install bolt-on kit, no drilling required. The strong, adjustable bracket also allows positioning to the customers requirements.

FEATURES:

- ❑ Valves are available in 2 & 3 spool
- ❑ Valves handle flows from 15 to 17 G.P.M. (10-13 G.P.M. through the ports) @ 3000 PSI
- ❑ Brackets available for most popular models on Case, New Holland, John Deere and Kubota compact tractors
- ❑ Bracket assemblies consist of rollbar clamp, adjustable arm with valve mounting and safety valve cover



To make box scrapers more versatile, nothing works better than being able to control the tilt and pitch of the implement. Grading jobs are more accurate because you have complete control to develop the slopes you require when landscaping, building roads, etc.

Top & Tilt Cylinders

FEATURES:

- ❑ Cylinders are specially designed to fit your tractor
- ❑ Cylinders are available in 2", 2 1/2" and 3" bore, depending on the tractor size
- ❑ Cylinders can be purchased in any combination, top only, tilt only or both



CAUTION: *If you extend the top link cylinder to the maximum on some box scrapers and completely collapse or extend the side link cylinder, a box scraper shank could damage the tractor tire.*





**1 1/2 TON
REAR DUMP**



**2 1/2 TON
REAR DUMP**



**4 TON 3-WAY
DUMP**



**5 TON 3-WAY
DUMP**



**8 TON REAR
DUMP**

SPECIFICATIONS:

MODEL NO:	1.5T50X72	2.5T60X96	4T63X99	5T63X99	8T60X120
Capacity Weight:	1.5 Ton	2.5 Ton	4 Ton	5 Ton	8 Ton
Capacity:	35 cu. ft.	77 cu. ft.	2.5 cu. yd.	2.5 cu. yd.	3.5 cu. yd.
Tire Size:	18 x 9.5 - 8	23 x 10.5 - 12	11L x 15	11L x 15	11L x 15
No. of Tires:	4	4	2	4	4
Weight:	600#	1500#	1800#	1875#	2000#
Bed Width:	50"	60"	63"	63"	60"
Bed Length:	70"	94"	99"	99"	120"
Bed Height:	21"	30"	33"	33"	31"
Bed Floor:	12 Ga. Steel	3/16" Plate	3/16" Plate	3/16" Plate	3/16" Plate
Overall Width:	54"	64"	68"	66"	88"
Overall Length:	8' - 6"	11' - 8"	11' - 6"	11' - 6"	13' - 8"
Overall Height:	34"	52"	61"	61"	61"
Dump Angle:	45°	45°	45°	45°	45°
Side Panels:	13" High	14" High	14" High	14" High	16" High
Rear Panel:	14" High	19" High	18" High	18" High	24" High
Front Panel:	13" High	19" High	18" High	18" High	24" High

FEATURES:

- 5 Sizes and capacities to choose from
- Available in rear and 3-way dump
- Models in single and tandem axle
- Rear hinged tailgate on all models
- Foldaway tongue jacks
- Swivel clevis type hitches

FOR OFF ROAD USE ONLY