



# VENTURI AIR SPRAYERS

## TRAILER MOUNTED 300 & 500 GALLON CAPACITIES



*"10 Year Warranty on Polyethylene Trailer Tanks"*



*500 Gallon Shown*

*Optional Floatation Tracks smooths out the ride, floats over wet ground and greatly reduces compaction.*



These unique Venturi Air Sprayers feature our most powerful high speed turbine fans and are the latest technology in low volume spraying. Thus, growers achieve the following benefits: spray atomization of droplets are smaller and more uniform, less fill-ups, even distribution of concentrated spray, complete foliage coverage, better product utilization, less chemical waste and soil/water contamination.

Our Venturi Air Sprayers are available with many different spray heads to fit exact profile of your crops. All sprayers with your required spray heads are then completely assembled at our warehouse to insure quality.

*Many different distribution spray heads are available.*



*Sprayer operating with 2 lower and 2 upper orchard distribution heads to insure coverage on the upper half of trees*



13477 Benson Ave. • Chino, CA 91710  
Ph: 909/548-4848 • Fax: 909/548-4747

[www.gearmore.com](http://www.gearmore.com) • [sales@gearmore.com](mailto:sales@gearmore.com)



# TRAILER MOUNTED VENTURI AIR SPRAYERS

## FEATURES:

- Molded polyethylene 300 and 500 gallon tanks
- Translucent heavy walled tanks with hinged lid, strainer basket and shower head
- High performance precision balanced all steel, front mounted turbine fan
- Dual centrifugal pumps - 37 G.P.M. for spraying and 37 G.P.M. for agitation
- Low pressure spraying system - 15 to 40 PSI spraying pressure means less maintenance on pumps and nozzles
- Wheels are adjustable up or down, front or rear, or in and out to obtain the best balance and clearance
- Electro valve system controls spray off or on, both sides spray, and right or left only
- No gearbox for fan speed-up, unique simple power band system with built-in overrunning clutch
- Separate safety clean water 8 gallon tank for hand washing
- Dolly wheel adjustable parking stand



*Low pressure centrifugal pump made of anti-corrosive materials requires little maintenance*

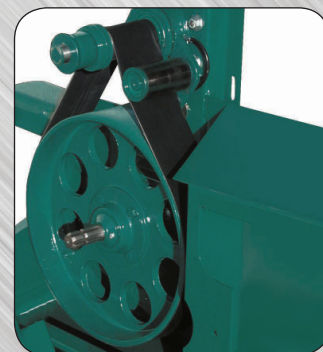

*Power band fan speed up system with built-in overrunning clutch*

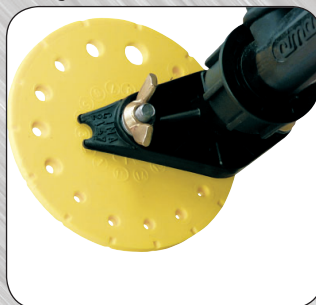

*Rotating yellow calibration discs, adjusts easily to provide accurate and constant regulation of application*



*Shower head is built into the main strainer basket to easily put wettable powders into suspension*

*Your Gearmore Dealer:*



*Electro valve controls to operate on, off, left, and right spraying*

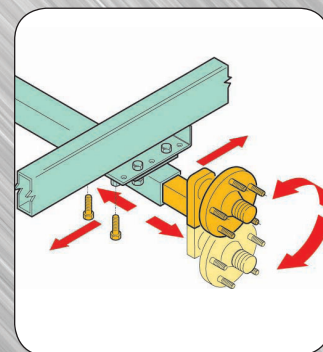

*Wheels adjust up or down, in or out, front or rear to obtain best balance and clearance*

## SPECIFICATIONS:

Model No.	Gallons	Volume of Air	Min. Width	Length	Tire Size	H.P. Required	WT.
T55S2-1200	300 Gal.	8240 C.F.M.	55"	12'	11Lx15-8 Ply	60 H.P.	1020#
T55E2-1200	300 Gal.	9123 C.F.M.	57"	12'	11Lx15-8 Ply	74 H.P.	1020#
T55E2-2000	500 Gal.	9123 C.F.M.	71"	14'	12.5Lx15-10 Ply	74 H.P.	1320#

*Specifications Subject To Change Without Notice*

13477 Benson Ave. • Chino, CA 91710 • Ph: 909/548-4848 • Fax: 909/548-4747