



# COLLARD®

## TREE SKIRTER MANUAL ADJUSTMENT

### FOR HIGH PRODUCTION SKIRTING OF ORCHARDS



This COLLARD Skirter trims half rows with 2 high speed stainless steel blades. The heart of this Skirter is the unique lightweight aluminum alloy extrusion that provides a rugged rust proof frame work for the cutting knives. The blade housings are so strong that they have a **lifetime guarantee**.

The COLLARD Tree Skirter is a fast, effective way to keep lower branches off the ground. The main reason to skirt trees is to prevent easy access of all types of pests. Another important reason to skirt is to provide clearance for other operations, such as spraying and mowing.

The Skirter has a unique design which allows for use on flat, hilly and terraced orchards.

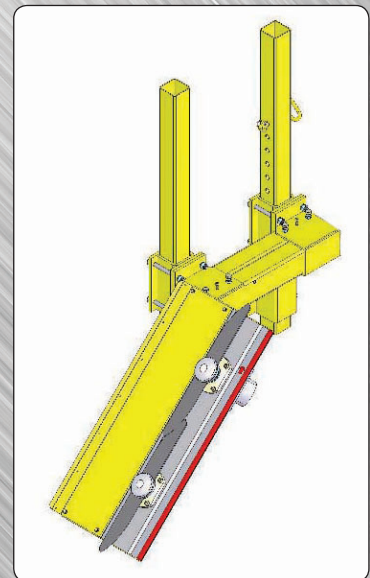

Distributed By:

**GEARMORE INC.**

13477 Benson Ave. • Chino, CA 91710

Ph: 909/548-4848 • Fax: 909/548-4747

[www.gearmore.com](http://www.gearmore.com) • [sales@gearmore.com](mailto:sales@gearmore.com)





# COLLARD®

## TREE SKIRTER

### FEATURES For P1000SK:

- Skirter is strong but lightweight and easy to operate
- Heavy double tubing main frame
- Double tubing socket bracket to mount on tractor frame
- High speed stainless steel blades - 18 7/8" long
- High capacity 10cc hydraulic motor
- Fitted with hydraulic block
- Sliding horizontal tubing extends 20" to right side, manual
- Sliding vertical tubing 20" up/down, manual
- Cutting housing is 35" long and angles down manual 0° to 45°
- Blade housing has safety break away system
- Flow limiter for hydraulic motor controls
- Smooth, thin line blade transmission housing for easy movement through the foliage
- Wide range of adjustments for positioning skirts to each grower requirements
- Blades turn at 2200 R.P.M. ensures clean cut of branch ends which dry and seal to reduce the risk of disease
- This unit runs smooth and quiet with no vibration
- Heavy duty shipping/storage stand for storing skirter
- Comes complete with hydraulic hoses and quick couplers

### OPTION:

- ~ Stainless steel swing knives 17 3/4" diameter for large branches

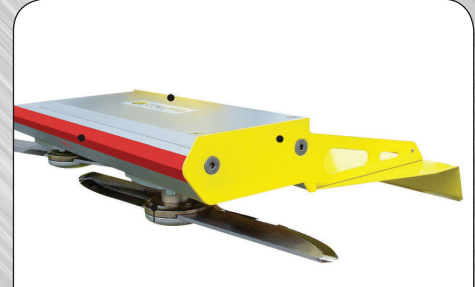

*Blade housing is strong enough to "guarantee for life"*



*Hydraulic motor provides high powered transmission to blades*



*Optional swing knives for branches up to 1" in diameter*

### SPECIFICATIONS:

ORDER NUMBER	MODEL NUMBER	CUTTING LENGTH	NO. OF BLADES	HYDRAULIC REQUIREMENTS	SHIPPING WEIGHT
013700950	P1000SK	35"	2	Max. 8 G.P.M.	410 lbs.

*Specifications Subject To Change Without Notice*

13477 Benson Ave. • Chino, CA 91710 • Ph: 909/548-4848 • Fax: 909/548-4747