

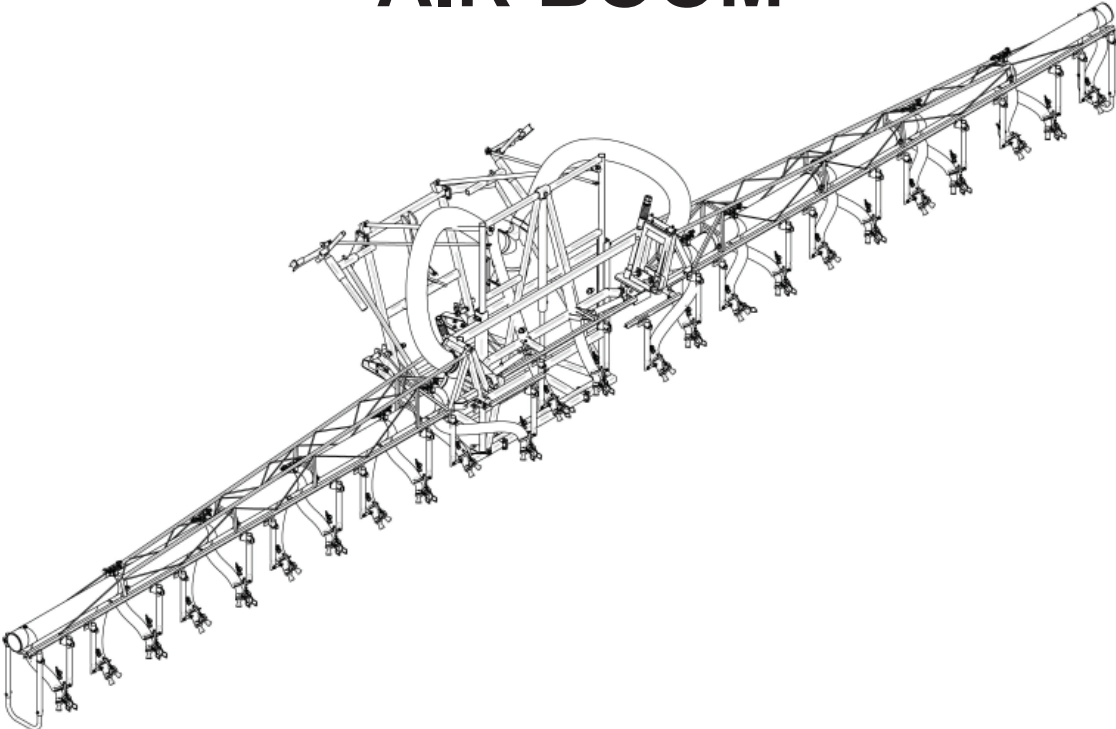

VENTURI AIR SPRAYERS 40 FOOT STRAWBERRY AIR BOOM



**PARTS MANUAL FOR
B212/35055/G BOOM
FOR P55S1 SPRAYER**

April 2014

TABLE OF CONTENTS

<u>SECTION</u>	<u>DESCRIPTION</u>	<u>PAGE</u>
1	Introduction	1
1.1	Purchaser's Responsibility	1
1.2	Serial Number Information	1
2	Complete Frame	2 - 10
2.01	Frame Support	3-4
2.02	Left Side Section	5-9
2.03	Sliding Center Section	6-9
2.04	Right Side Section	7-9
2.05	Nozzle Protection Guard	10
3	Complete Air Routing	11 - 20
3.01	Air Routing	12
3.02	L.H. Sliding Bracket	13-14
3.03	R.H. Sliding Bracket	15-16
3.04	L.H. Sliding Bracket	17-18
3.05	R.H. Sliding Bracket	19-20
4	Liquid Flow Path	21 - 26
4.01	Fittings Flow Path	22
4.02	Fittings, Liquid Flow Path	24-24
4.03	Fittings, Liquid Flow Path	25-26
4.04	Complete Anti-drip Nozzle Assy	27
5	Limited Warranty	28

INDEX

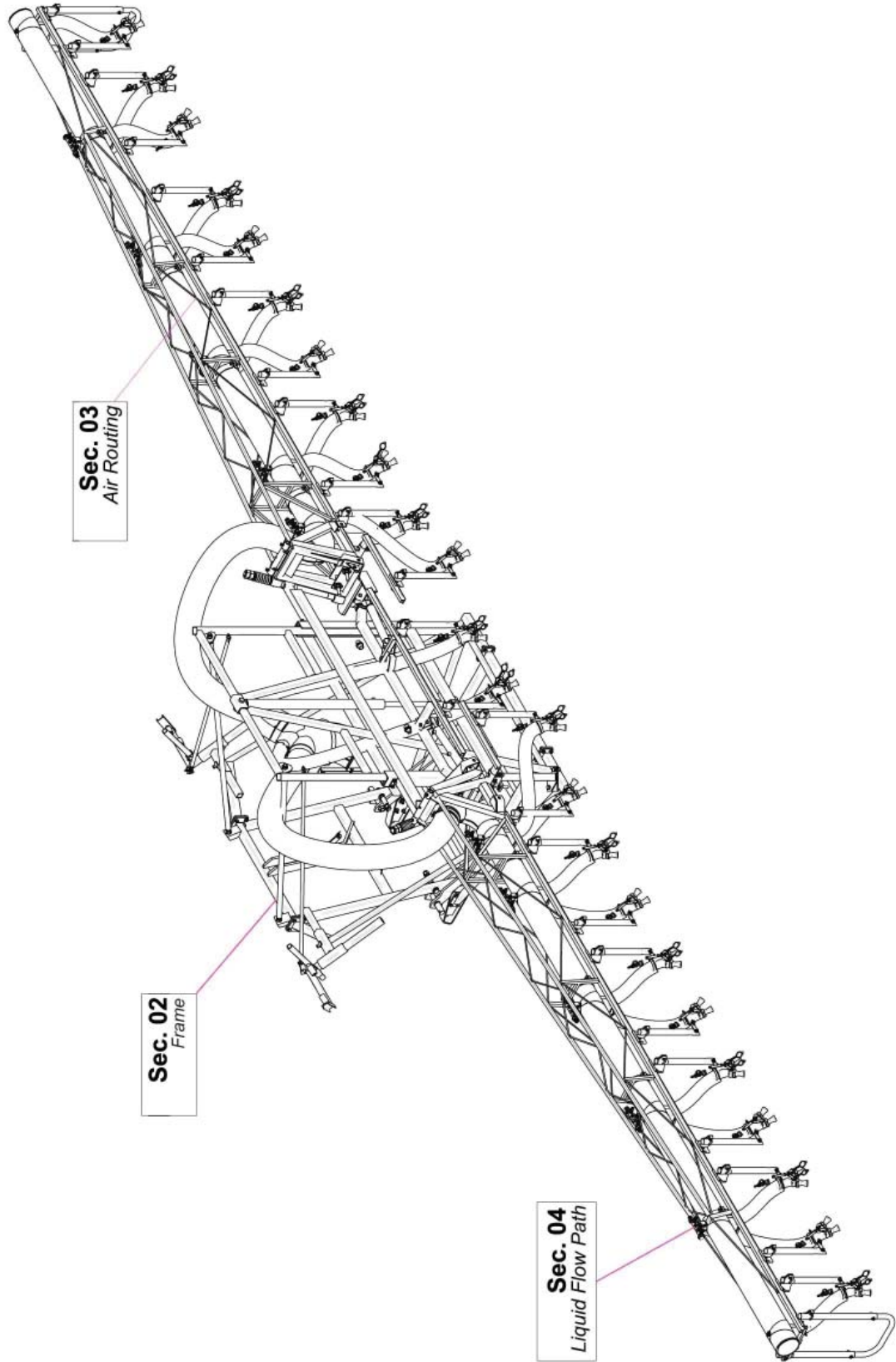

1 INTRODUCTION

We welcome you as an owner of a Gearmore sprayer. Please read the following instructions and refer to them when required. This manual contains parts diagrams and replacement parts lists. Do not modify the equipment in any way. Unauthorized modification may impair the function and/or safety and could affect the life of the equipment.

Where replacement parts are necessary for periodic maintenance and servicing, genuine factory replacement parts ***MUST*** be used to restore your equipment to original specifications. The manufacturer will not be responsible for injuries or damages caused by use of unapproved parts and/or accessories.

The manufacturer reserves the right to make improvements to the machinery and parts at any time and at their discretion.

OPERATOR ORIENTATION - The directions left, right, front and rear, are as seen from the driver's seat and facing in the direction of travel.

1.1 PURCHASER'S RESPONSIBILITY

It is the responsibility of the owner to make sure the machine is maintained properly, and that all parts are in working order. It is the responsibility of the purchaser and/or operator to.....

- Inspect the equipment and replace or repair any parts that are damaged or worn which under continued operation would cause damage, wear to other parts, or cause a safety hazard.
- Return the equipment or parts to the authorized dealer, from where it was purchased, for service or replacement of defective parts that are covered by warranty. (The factory may inspect equipment or parts before warranty claims are honored.)
- Payment of all costs incurred by the dealer for traveling to or transporting the equipment for warranty inspection and/or claims.

1.2 MODEL / SERIAL NUMBER

NAME: _____

PURCHASED FROM: _____

DATE OF PURCHASE: _____

MODEL NUMBER: _____

SERIAL NUMBER: _____

2 COMPLETE FRAME

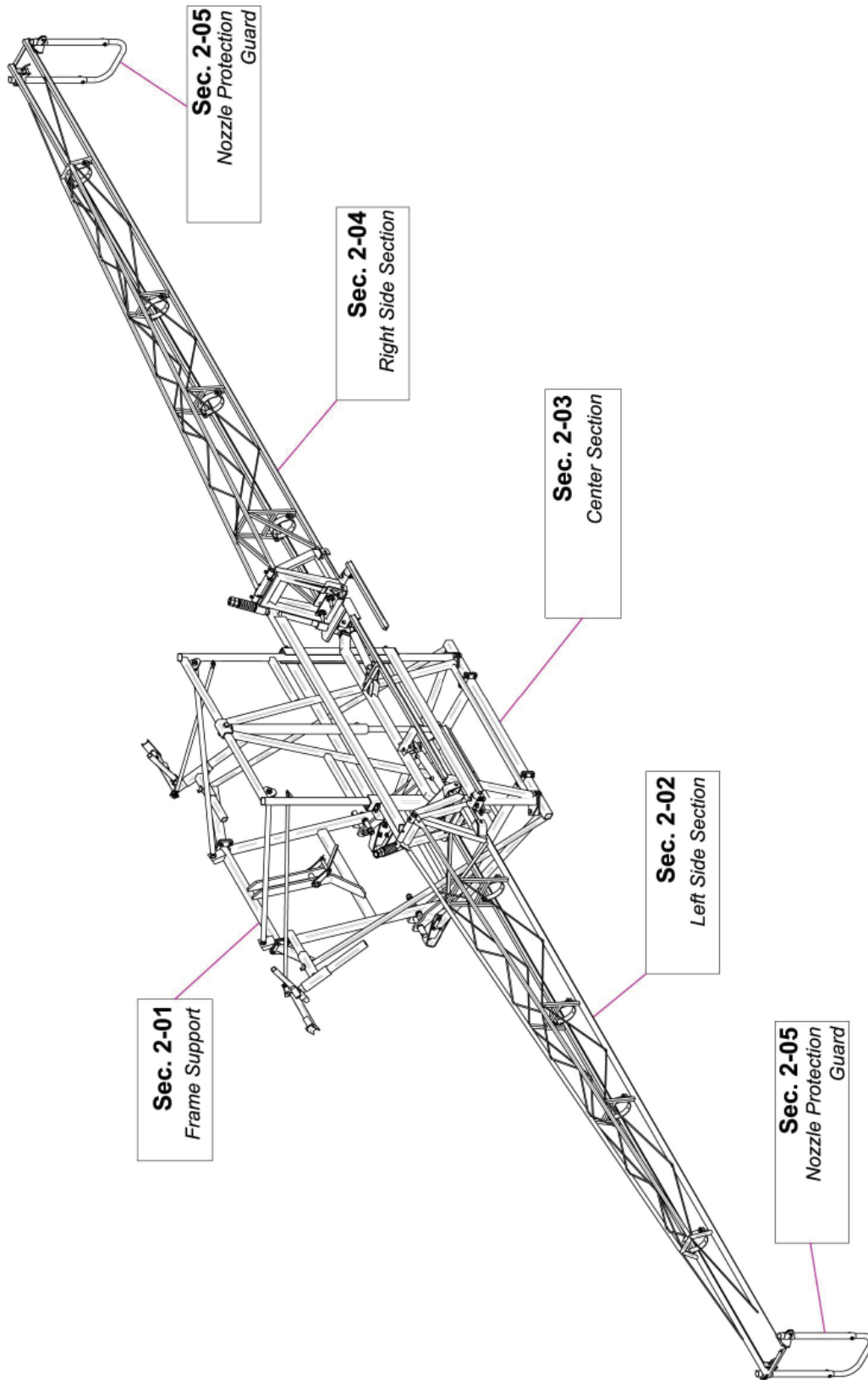

2 COMPLETE FRAME

Sec. 01 FRAME SUPPORT

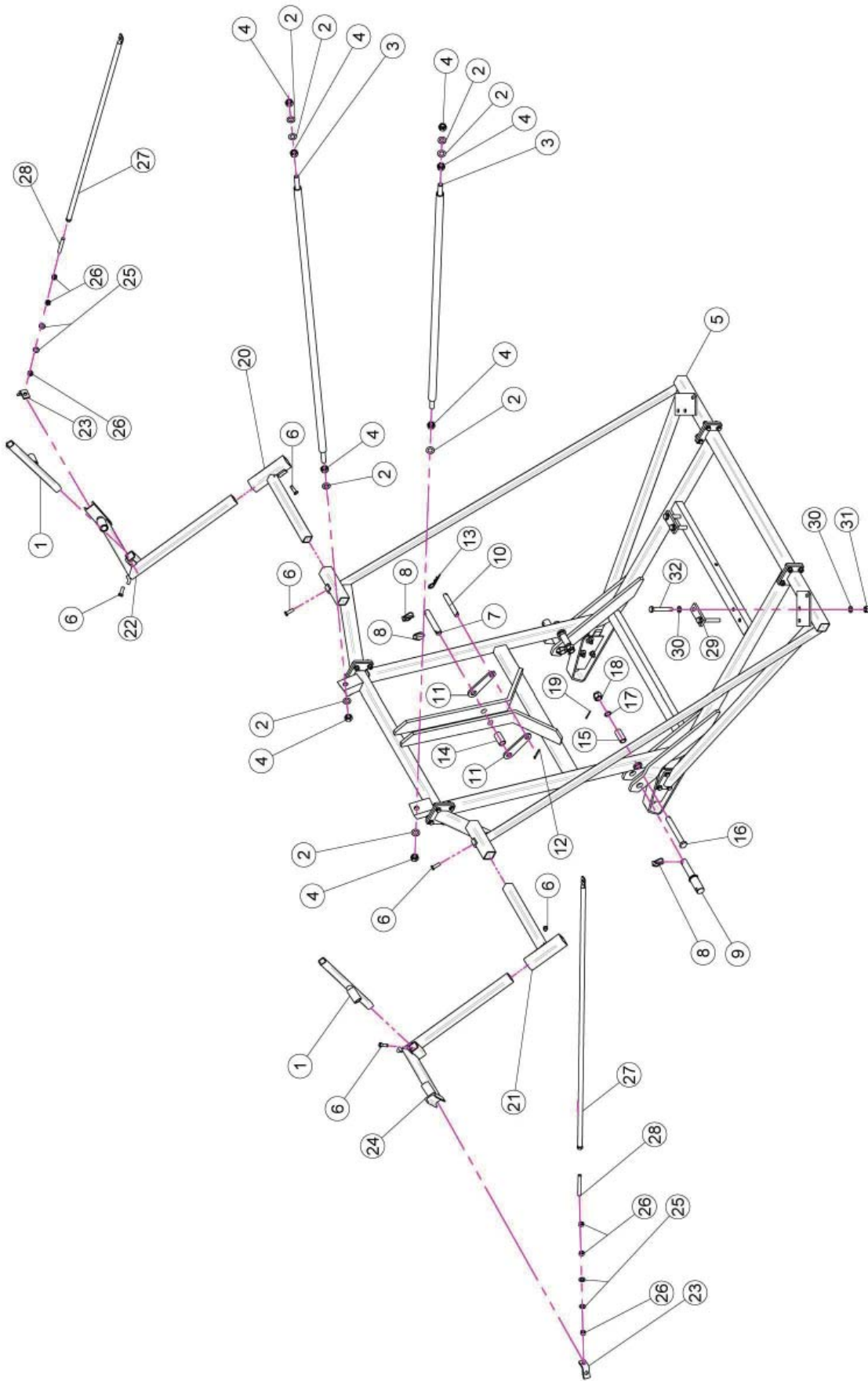

2 COMPLETE FRAME

Sec. 01 FRAME SUPPORT

<u>REF #</u>	<u>QTY.</u>	<u>PART NO.</u>	<u>DESCRIPTION</u>
1	2	20.324.000	Bracket For Side Section At Rest
2	8	RP.020.000	Washer D.20
3	2	20.295.001	Rod Fixing Lower & Top Frame
4	8	D0.20.5587G	Nut M20
5	1	21.065.001	Frame Assembly
6	6	TE.012.035T	Screw TE M12 x 36
7	1	20.312.001	Pin
8	4	02.439.000	Pin D.10
9	2	20.311.000	Pin
10	1	20.314.001	Pin For 3-Point
11	2	20.298.003	Tie Rod
12	1	CP.006.040I	Pin D.6 Lg.40
13	1	00.100.004	Split Pin D.4
14	1	20.778.100	Bush
15	2	40.202.001	Bush
16	2	40.201.200	Pin Power Lift
17	2	RD.022.000	Tab Washer D.22
18	2	DI.022.5593F	Castle Nut (6 Slots) M22
19	2	CP.004.040	Split Pin D.4 L=40
20	1	20.338.000DX	Bracket
21	1	20.338.000SX	Bracket
22	1	20.323.000SX	LH Supporting For Side Section At Rest
23	2	20.496.000	Shaped Plate With Holes
24	1	20.323.000DX	RH Supporting For Side Section At Rest
25	4	RP.014.000	Washer D.14
26	6	D0.14.5587G	Nut M14
27	2	20.495.000	Rod
28	2	BRF.014.050	Bar
29	2	20.656.000	Bracket Fixing Mounted To The Lower Frame
30	8	RP.016.000	Washer D.16
31	4	D0.16.5587G	Nut M16
32	4	TE.016.110	Screw TE M16 x 110

2 COMPLETE FRAME

Sec. 02 LEFT SIDE SECTION

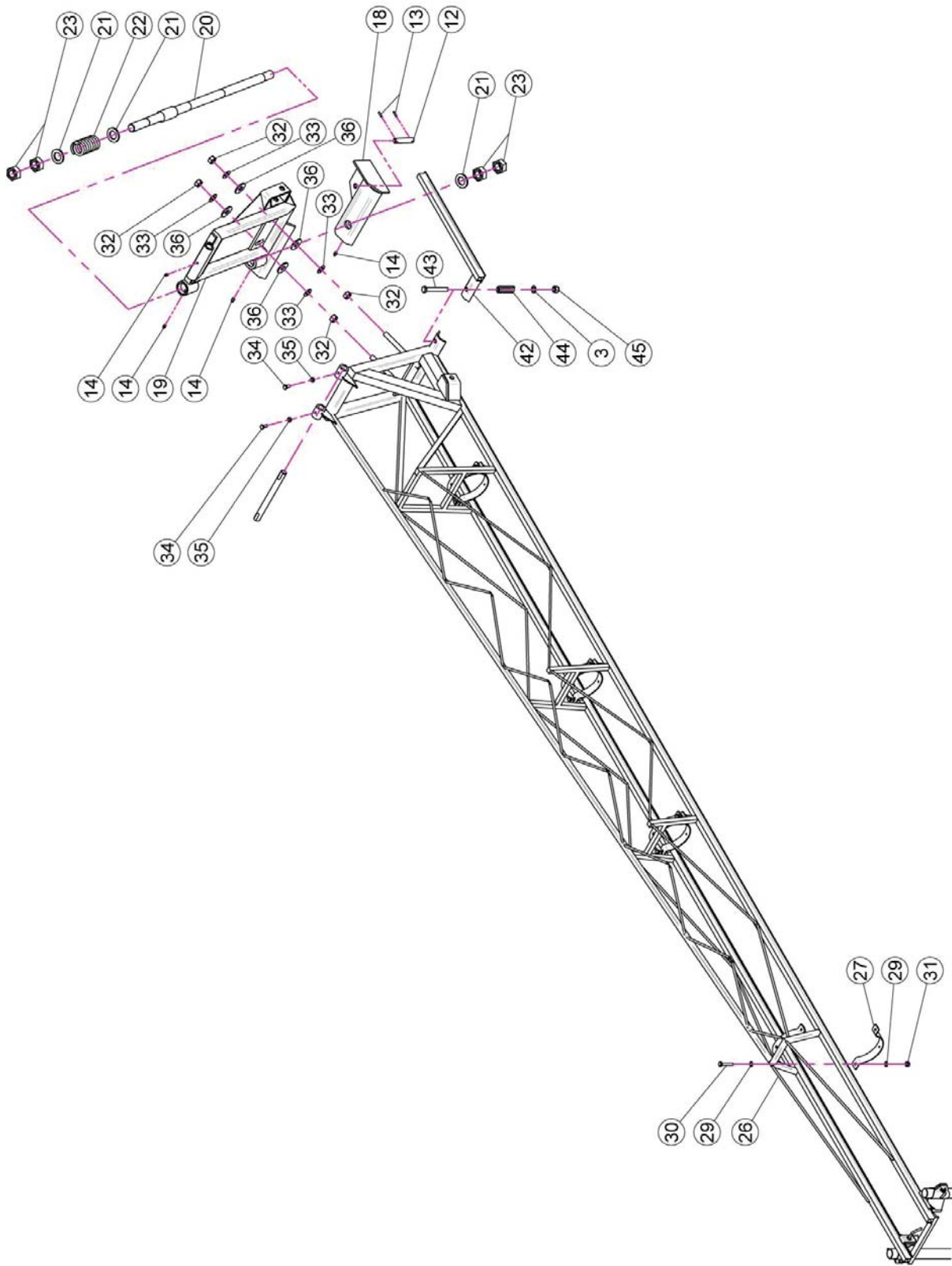

2 COMPLETE FRAME

Sec. 03 SLIDING CENTER SECTION

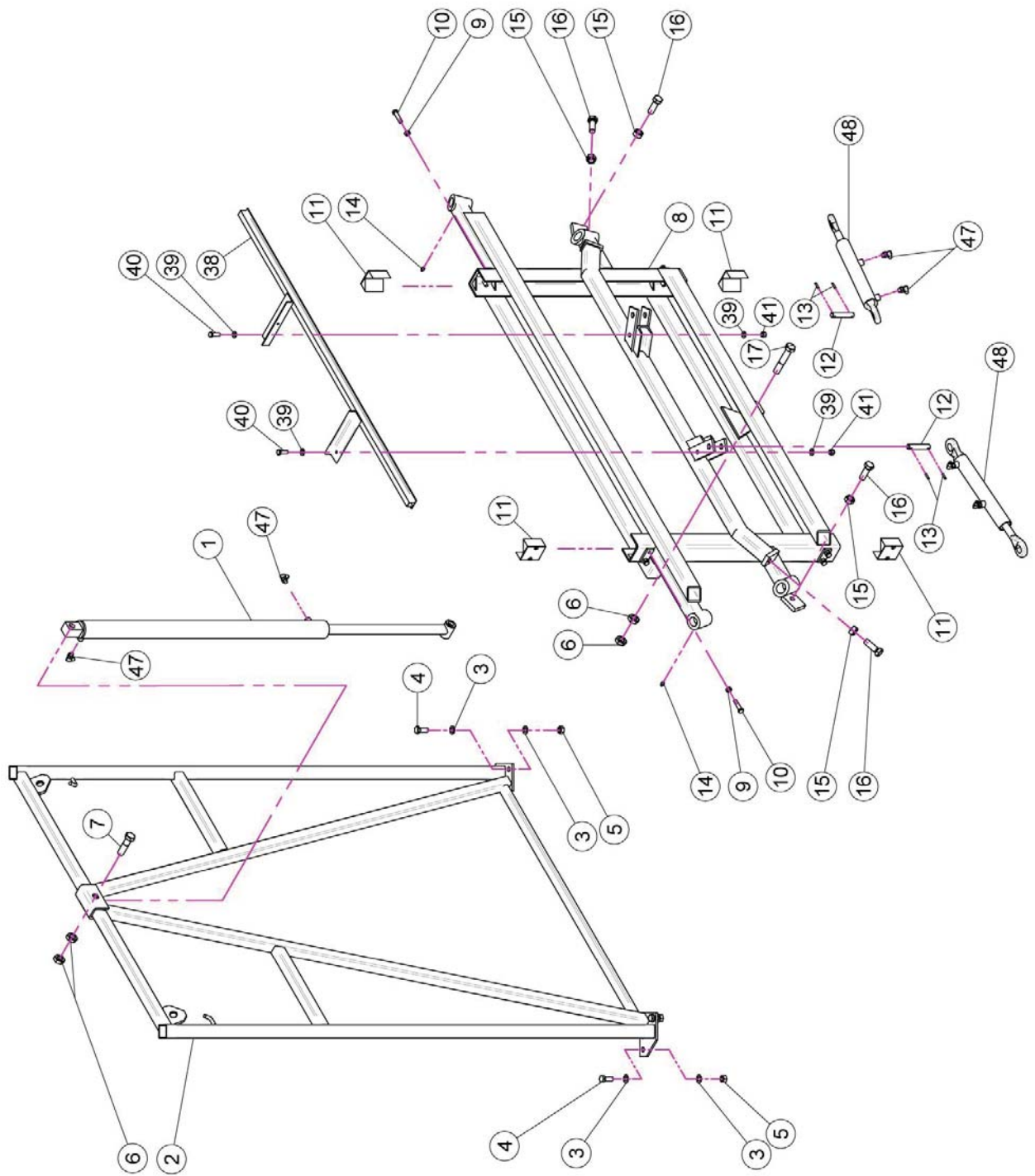

2 COMPLETE FRAME

Sec. 04 RIGHT SIDE SECTION

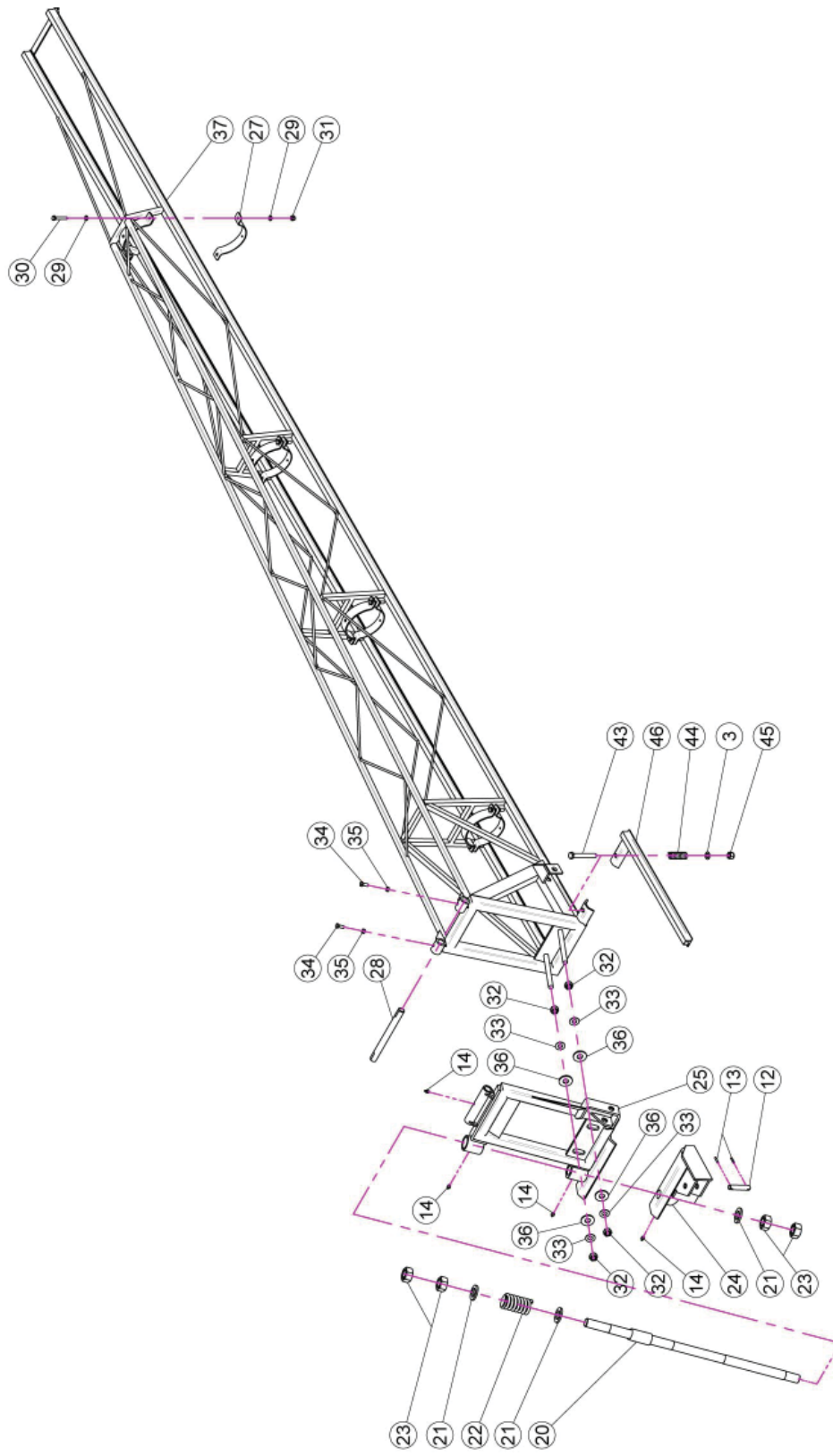

2 COMPLETE FRAME

Sec. 02_03_04 PARTS LIST

<u>REF.</u>	<u>QTY.</u>	<u>PART NO.</u>	<u>DESCRIPTION</u>
1	1	20.199.01C	Cylinder
2	1	20.293.000	Top Frame
3	14	RP.016.000	Washer D.16
4	6	TE.016.040T	Screw TE 16 x 40
5	6	D0.16.5587G	Nut M16
6	4	D0.22.5589G	Nut M22 6S
7	1	TE.022.080	Screw TE M22 x 80
8	1	20.294.000	Sliding Frame
9	8	D0.12.5588G	M12 6S Big Lead Nut 5588
10	8	TE.012.050T	Screw M12 x 50T
11	4	20.326.000	Guide
12	4	20.329.000	Pin D.19 For Cylinders
13	8	SE.006.028	Elastic Pin
14	12	ID.010.001	Grease Nipple
15	4	D0.20.5587G	Nut M20
16	4	TE.020.060T	Screw TE M20 x 60
17	1	TE.022.120	Screw M22 x 120
18	1	20.321.000SX	Support Left
19	1	20.320.100SX	RH Supporting
20	2	20.318.000	Pin For Articulation
21	6	20.921.000	Washer D.60 x 26 SP.6
22	2	20.264.000	Spring
23	8	D0.33.5588F	Nut M33 6S
24	1	20.321.000DX	Support Right
25	1	20.320.100DX	RH Supporting
26	1	20.316.100SX	Pneumatic Bar Left Arm
27	8	20.322.000	INOX D.160 Semi Clamp
28	2	20.319.000	Pin For Hoisting
29	32	RP.010.000	Washer D.10
30	16	TE.010.060T	Screw TE M10 x 60
31	16	DA.010.0BG	Self Locking Nut M10
32	8	D0.18.5587G	Nut M18
33	8	RP.018.000	Washer
34	4	TE.010.025T	Screw TE 10 x 25T
35	4	D0.10.5588G	M10 6S Big Lead Nut 5588
36	8	20.820.000	Washer
37	1	20.316.100DX	Pneumatic Bar Right Arm
38	1	20.317.000	Central Carrier Outlet Bracket
39	4	RP.012.000	Washer D.12

2 COMPLETE FRAME

Sec. 02_03_04 PARTS LIST

<u>REF #</u>	<u>QTY.</u>	<u>PART NO.</u>	<u>DESCRIPTION</u>
40	2	TE.012.035T	Screw TE M12 x 35
41	2	DA.012.0AG	Self Locking Nut M12
42	1	20.287.000SX	Outlets Carrier Left Bracket
43	2	TE.016.110	Screw TE M16 x 110
44	2	07.544.000	Spring
45	2	DA.016.0AG	Self Locking Nut M16
46	1	20.287.000DX	Outlets Carrier Right Bracket
47	8	02.409.000	Elbow With Retaining Ring Seal
48	2	20.147.01C	Cylinder

2 COMPLETE FRAME

Sec. 05 NOZZLE PROTECTION GUARD

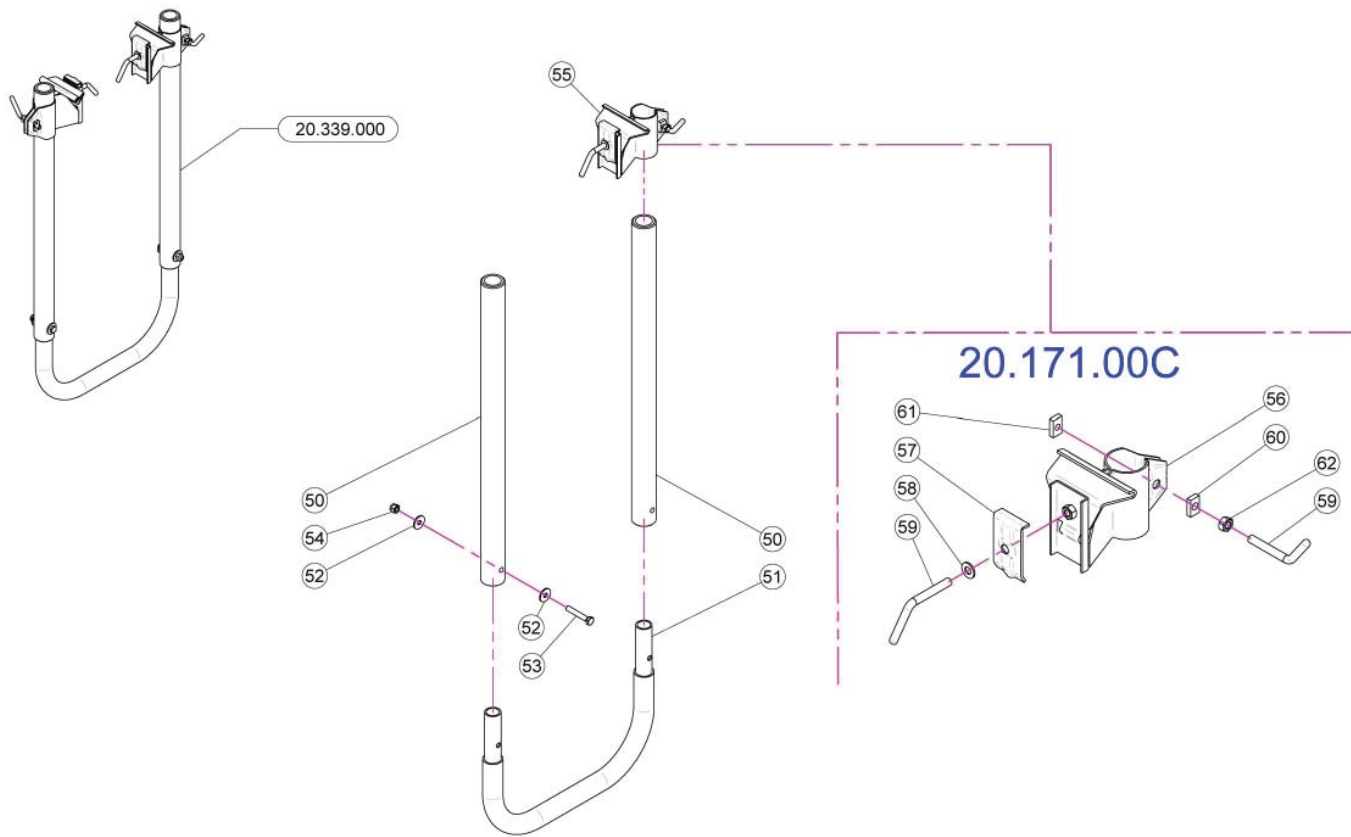

<u>REF.</u>	<u>QTY.</u>	<u>PART NO.</u>	<u>DESCRIPTION</u>
50	2	20.341.000	Polyethylene Hose Ø40 Lg. 600
51	1	20.342.001	Bumper
52	4	RP.008.024	Washer D.8 x 24
53	2	TE.008.050T	Screw TE M8 x 50
54	2	DA.008.0AG	Self Locking Nut M8
55	2	20.171.00C	Sliding Bracket Air Boom

20.171.00C

56	1	20.171.000	Sliding Bracket
57	1	20.068.000	Bracket
58	1	RP.008.000	Washer D.8
59	2	20.069.000	Threaded Handle M8
60	1	20.071.000	Square Nut M8
61	1	20.070.000	Square Nut M8
62	1	D0.08.5588G	Nut M8

3 COMPLETE AIR ROUTING

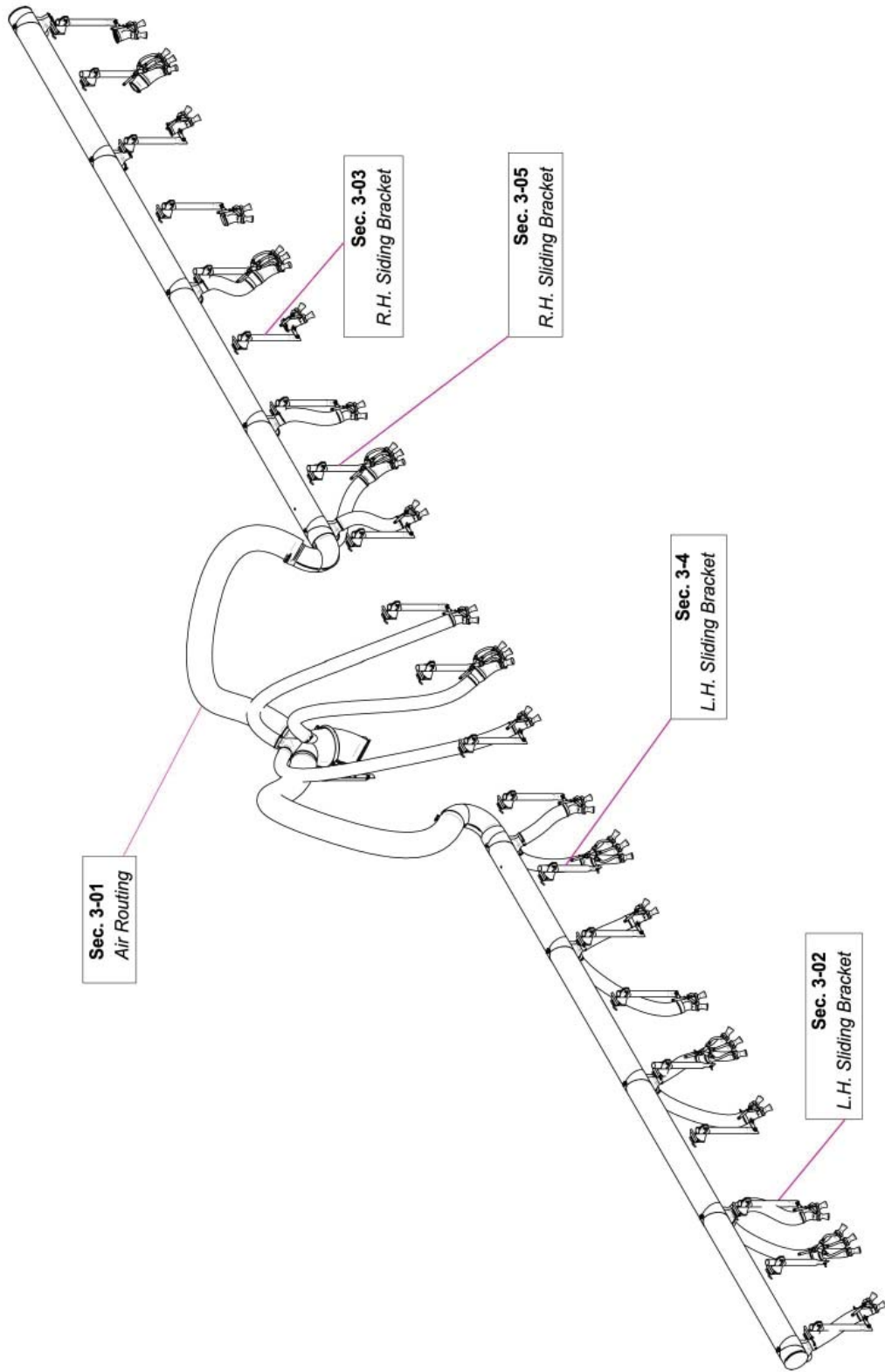

3 COMPLETE AIR ROUTING

Sec. 01 AIR ROUTING

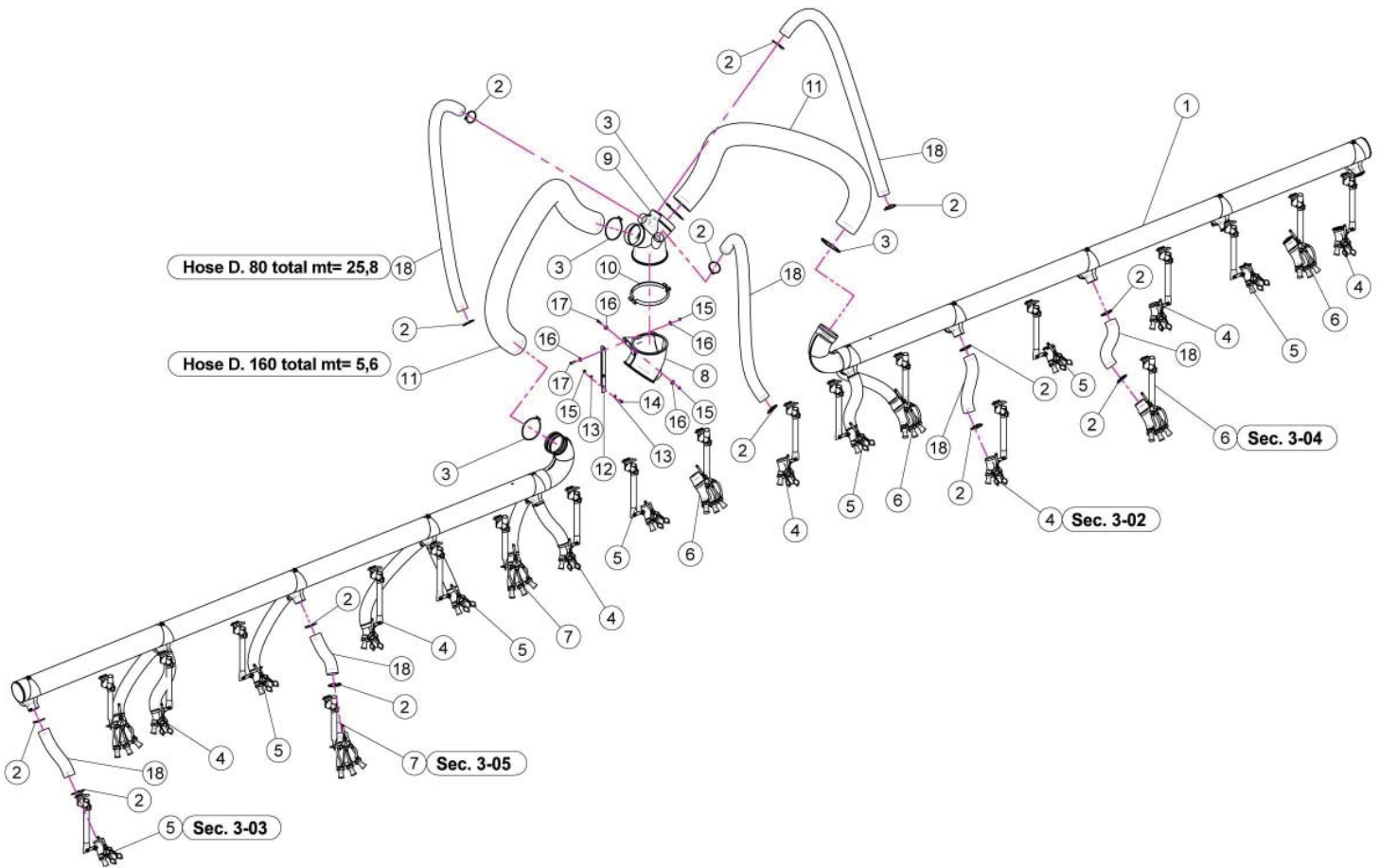

<u>REF.</u>	<u>QTY.</u>	<u>PART NO.</u>	<u>DESCRIPTION</u>
1	2	20.307.100	Air Duct
2	42	F0.080.000	Clamp D.80
3	4	F0.160.000	Clamp D.160
4	7	20.221.10CSX	2 Nozzles Kit D.80 With Bracket
5	7	20.221.10CDX	2 Nozzles Kit D.80 With Bracket
6	4	20.837.60CSX	3 Nozzles Kit D.80 With Bracket
7	3	20.837.60CDX	3 Nozzles Kit D.80 With Bracket
8	1	05.809.050	45° Bend D.250
9	1	20.286.100	Air Outlet Body From D.250 to D.160/80
10	1	05.813.000	Clamp D.275
11	As Req'd	160MMRFH	Hose D.160 (Per Foot)
12	1	05.809.051	45° Elbow Bracket
13	4	RP.010.000	Washer D.10
14	2	TE.010.025T	Screw TE 10 x 25T
15	5	D0.10.5587G	Nut M10
16	6	RP.010.030	Washer D.10 x 30 mm
17	3	TE.010.035T	Screw TE 10 x 35
18	As Req'd	80MMRFH+	Hose D.80 (Per Foot)

3 COMPLETE AIR ROUTING

Sec. 02 L.H. SLIDING BRACKET

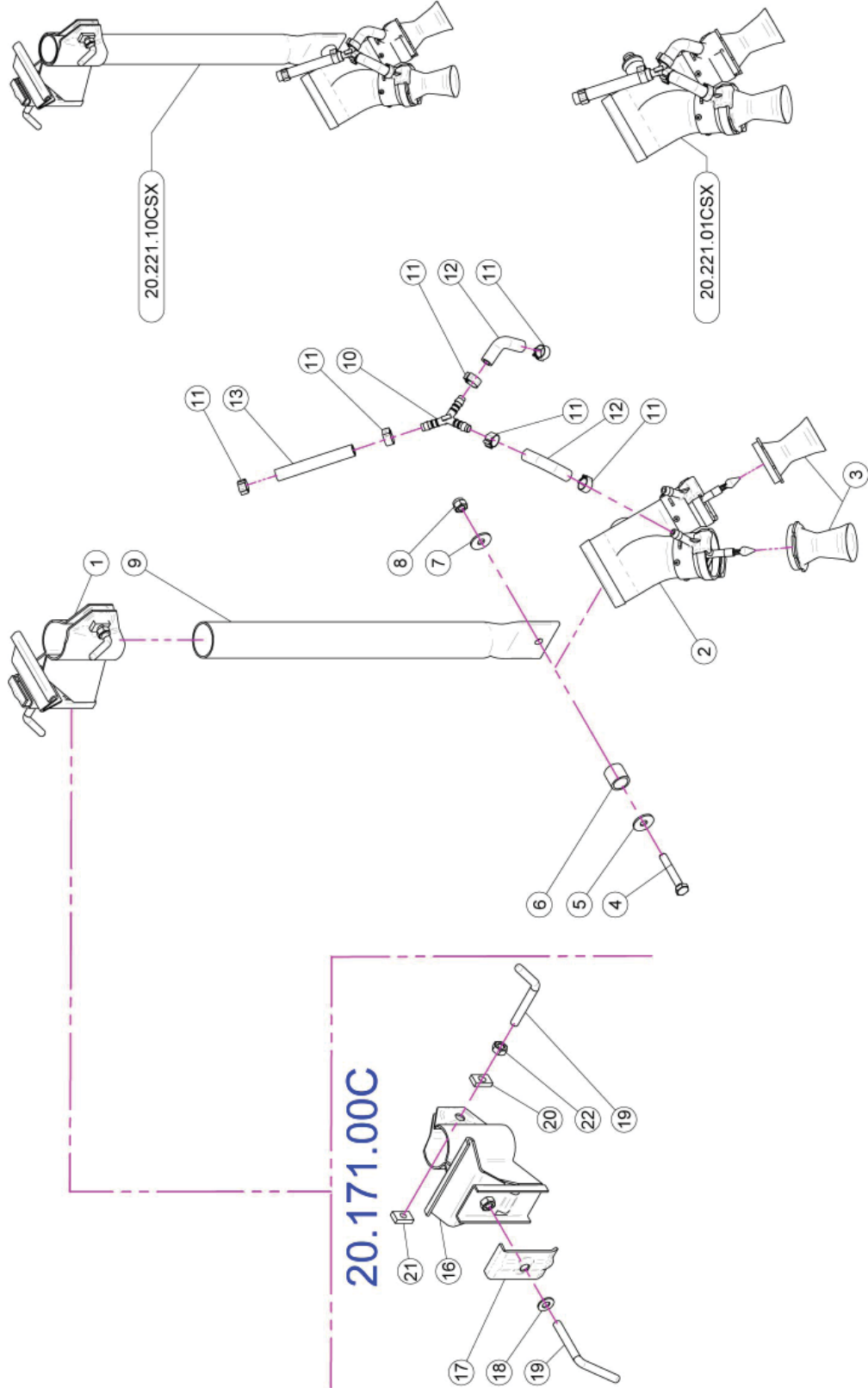

3 COMPLETE AIR ROUTING

Sec. 02 L.H. SLIDING BRACKET

<u>REF.</u>	<u>QTY.</u>	<u>PART NO.</u>	<u>DESCRIPTION</u>
1	1	20.171.00C	Sliding Bracket Air Boom
2	1	20.221.000SX	Complete 2 Nozzles Left Body Kit
3	2	00.003.5.50	Nozzle 3.5/50
4	1	TE.008.050T	Screw TE M8 x 50
5	1	RP.008.024I	INOX Washer D.8 x 24
6	1	20.265.000	Spacer
7	1	RP.008.024	Washer D.8 x 24
8	1	DA.008.0AG	Self Locking Nut M8
9	1	20.266.001	Bracket
10	1	02.077.010	Y Fitting
11	6	FC.013.5.015	Hose Clamp
12	As Req'd	02.217.000	Hose D.8 x 13 L=50 (Per Foot)
13	As Req'd	02.217.000	Hose D.8 x 13 L=90 (Per Foot)

20.171.00C

16	1	20.171.000	Sliding Bracket
17	1	20.068.000	Bracket
18	1	RP.008.000	Washer D.8
19	2	20.069.000	Threaded Handle M8
20	1	20.071.000	Square Nut M8
21	1	20.070.000	Square Nut M8
22	1	D0.08.5588G	Nut M8

3 COMPLETE AIR ROUTING

Sec. 03 R.H. SLIDING BRACKET

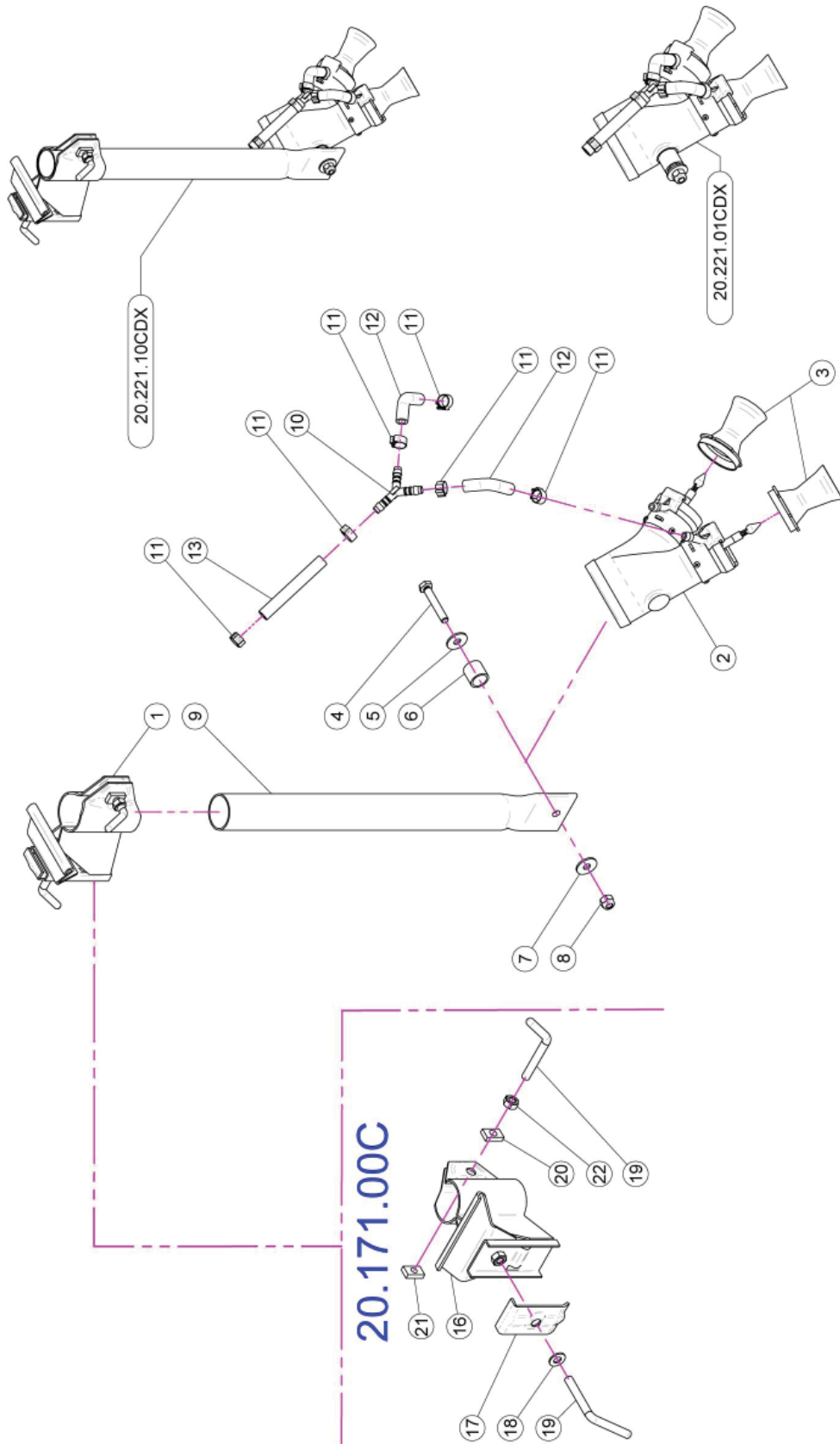

3 COMPLETE AIR ROUTING

Sec. 03 R.H. SLIDING BRACKET

<u>REF.</u>	<u>QTY.</u>	<u>PART NO.</u>	<u>DESCRIPTION</u>
1	1	20.171.00C	Sliding Bracket Air Boom
2	1	20.221.000DX	Complete 2 Nozzles Right Body Kit
3	2	00.003.5.50	Nozzle 3.5/50
4	1	TE.008.050T	Screw TE M8 x 50
5	1	RP.008.024I	INOX Washer D.8 x 24
6	1	20.265.000	Spacer
7	1	RP.008.024	Washer D.8 x 24
8	1	DA.008.0AG	Self Locking Nut M8
9	1	20.266.001	Bracket
10	1	02.077.010	Y Fitting
11	6	FC.013.5.015	Hose Clamp
12	As Req'd	02.217.000	Hose D.8 x 13 L=50 (Per Foot)
13	As Req'd	02.217.000	Hose D.8 x 13 L=90 (Per Foot)

20.171.00C

16	1	20.171.000	Sliding Bracket
17	1	20.068.000	Bracket
18	1	RP.008.000	Washer D.8
19	2	20.069.000	Threaded Handle M8
20	1	20.071.000	Square Nut M8
21	1	20.070.000	Square Nut M8
22	1	D0.08.5588G	Nut M8

3 COMPLETE AIR ROUTING

Sec. 04 L.H. SLIDING BRACKET

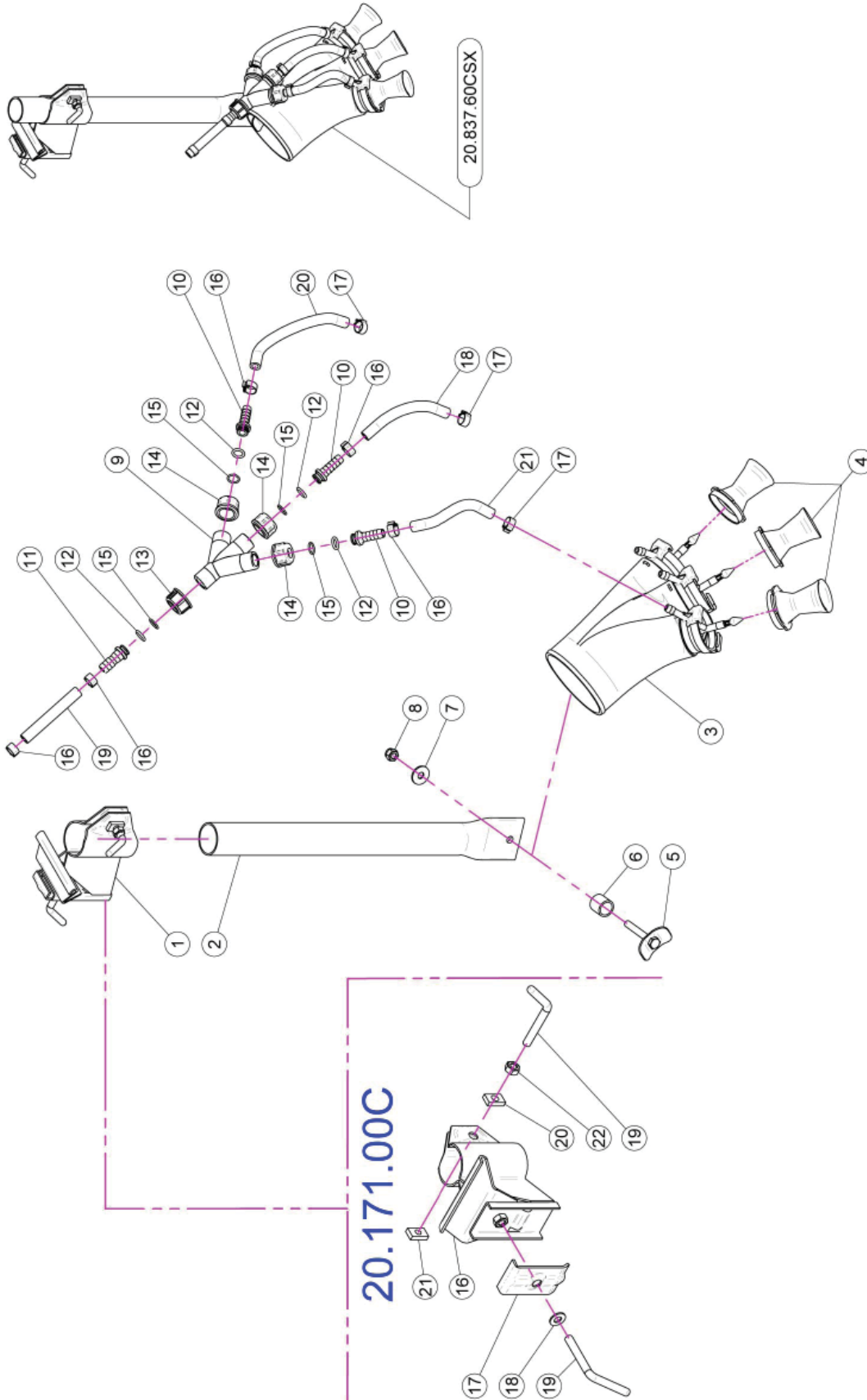

3 COMPLETE AIR ROUTING

Sec. 04 L.H. SLIDING BRACKET

<u>REF.</u>	<u>QTY.</u>	<u>PART NO.</u>	<u>DESCRIPTION</u>
1	1	20.171.00C	Sliding Bracket Air Boom
2	1	20.266.001	Bracket
3	1	20.837.300SX	D.80 Complete Poly Hand 3 Outlets
4	3	00.003.5.50	Nozzle 3.5/50
5	1	21.059.000	Fixing Screw For Poly Hand
6	1	20.265.000	Spacer
7	1	RP.008.024	Washer D.8 x 24
8	1	DA.008.0AG	Self Locking Nut M8
9	1	02.346.000	4 Ways Union
10	3	02.285.000	D.11 Union
11	1	02.286.000	D.13 R.H. Union
12	4	OR.003.043	D.10.78 x 2.62 O-Ring
13	1	02.288.000	D.13 R.H. Nut
14	3	02.287.000	Fly Nut 1/2"
15	4	07.602.000	D.13.9 x 1.75 O-Ring Gasket
16	5	FC.013.5.015	Hose Clamp
17	3	FC.012.5.014	Hose Clamp
18	As Req'd	02.217.000	Hose D.8 x 13 L=80 (Per Foot)
19	As Req'd	02.217.000	Hose D.8 x 13 L=90 (Per Foot)
20	As Req'd	02.217.000	Hose D.8 x 13 L=90 (Per Foot)
21	As Req'd	02.217.000	Hose D.8 x 13 L=90 (Per Foot)
<u>20.171.00C</u>			
16	1	20.171.000	Sliding Bracket
17	1	20.068.000	Bracket
18	1	RP.008.000	Washer D.8
19	2	20.069.000	Threaded Handle M8
20	1	20.071.000	Square Nut M8
21	1	20.070.000	Square Nut M8
22	1	D0.08.5588G	Nut M8

3 COMPLETE AIR ROUTING

Sec. 05 R.H. SLIDING BRACKET

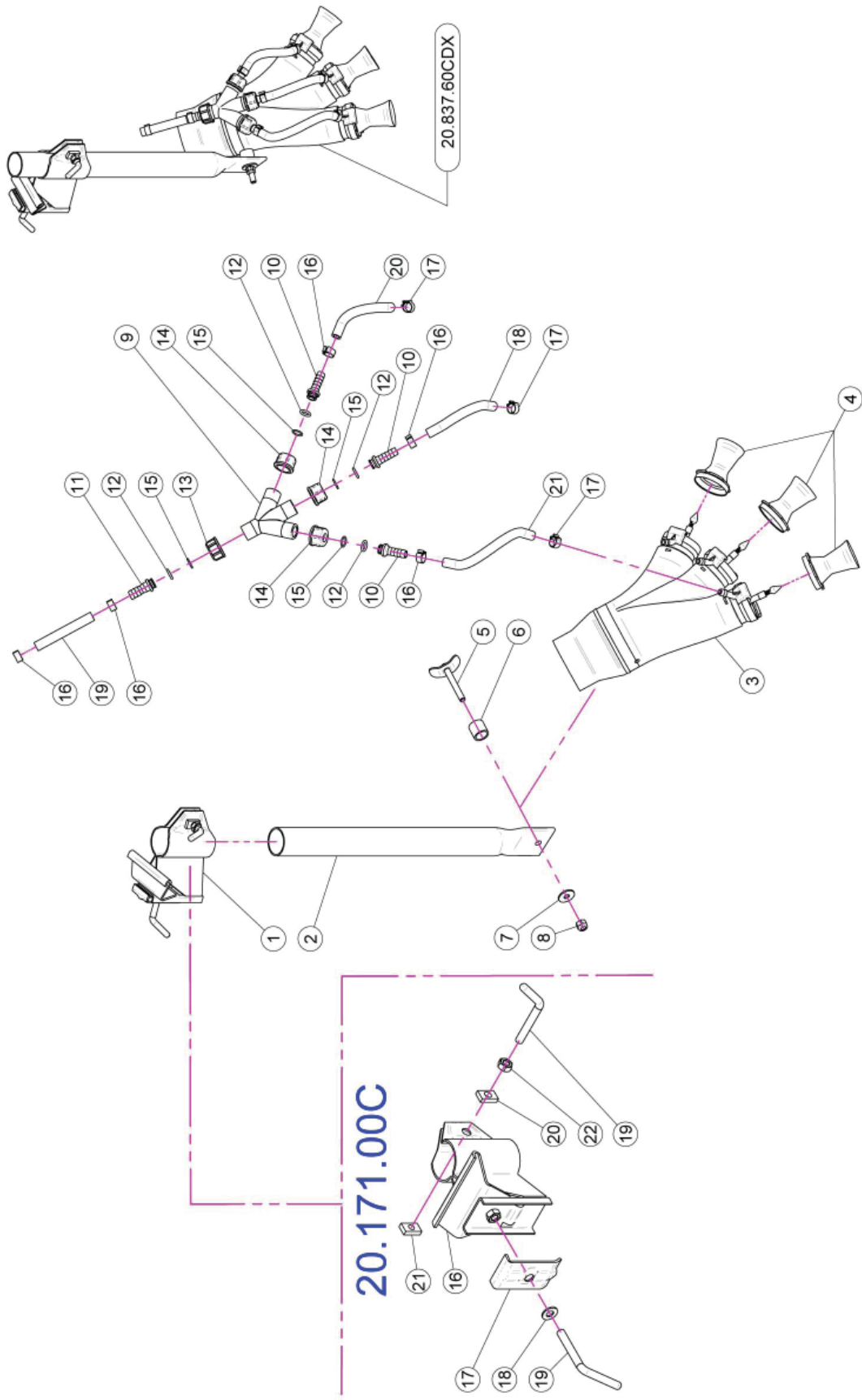

3 COMPLETE AIR ROUTING

Sec. 05 R.H. SLIDING BRACKET

<u>REF.</u>	<u>QTY.</u>	<u>PART NO.</u>	<u>DESCRIPTION</u>
1	1	20.171.00C	Sliding Bracket Air Boom
2	1	20.266.001	Bracket
3	1	20.837.300DX	D.80 Complete Poly Hand 3 Outlets
4	3	00.003.5.50	Nozzle 3.5/50
5	1	21.059.000	Fixing Screw For Poly Hand
6	1	20.265.000	Spacer
7	1	RP.008.024	Washer D.8 x 24
8	1	DA.008.0AG	Self Locking Nut M8
9	1	02.346.000	4 Ways Union
10	3	02.285.000	D.11 Union
11	1	02.286.000	D.13 R.H. Union
12	4	OR.003.043	D.10.78 x 2.62 O-Ring
13	1	02.288.000	D.13 R.H. Nut
14	3	02.287.000	Fly Nut 1/2"
15	4	07.602.000	D.13.9 x 1.75 O-Ring Gasket
16	5	FC.013.5.015	Hose Clamp
17	3	FC.012.5.014	Hose Clamp
18	As Req'd	02.217.000	Hose D.8 x 13 L=80 (Per Foot)
19	As Req'd	02.217.000	Hose D.8 x 13 L=90 (Per Foot)
20	As Req'd	02.217.000	Hose D.8 x 13 L=90 (Per Foot)
21	As Req'd	02.217.000	Hose D.8 x 13 L=90 (Per Foot)
<u>20.171.00C</u>			
16	1	20.171.000	Sliding Bracket
17	1	20.068.000	Bracket
18	1	RP.008.000	Washer D.8
19	2	20.069.000	Threaded Handle M8
20	1	20.071.000	Square Nut M8
21	1	20.070.000	Square Nut M8
22	1	D0.08.5588G	Nut M8

4 LIQUID FLOW PATH

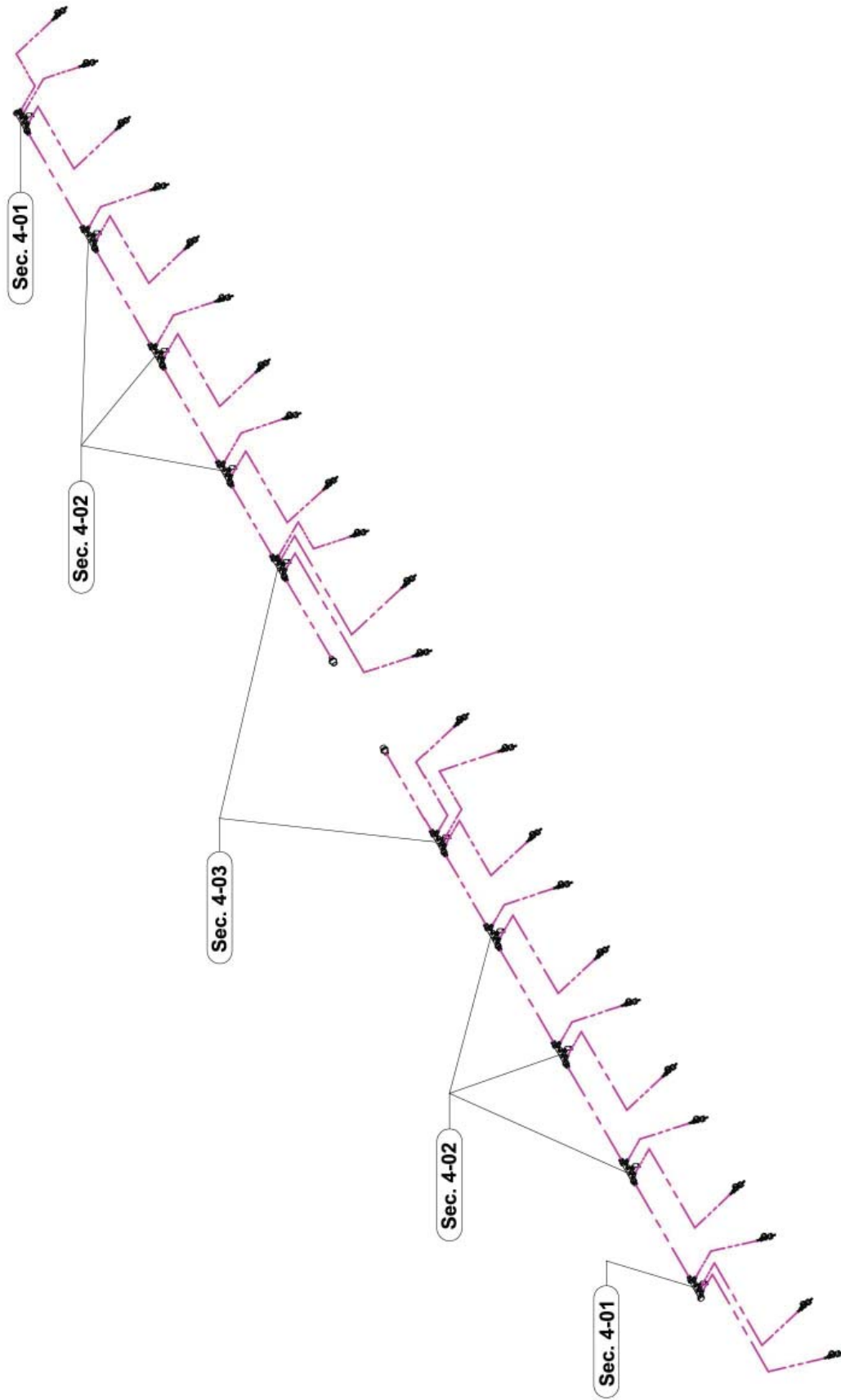

4 LIQUID FLOW PATH

Sec. 01 FITTINGS FLOW PATH

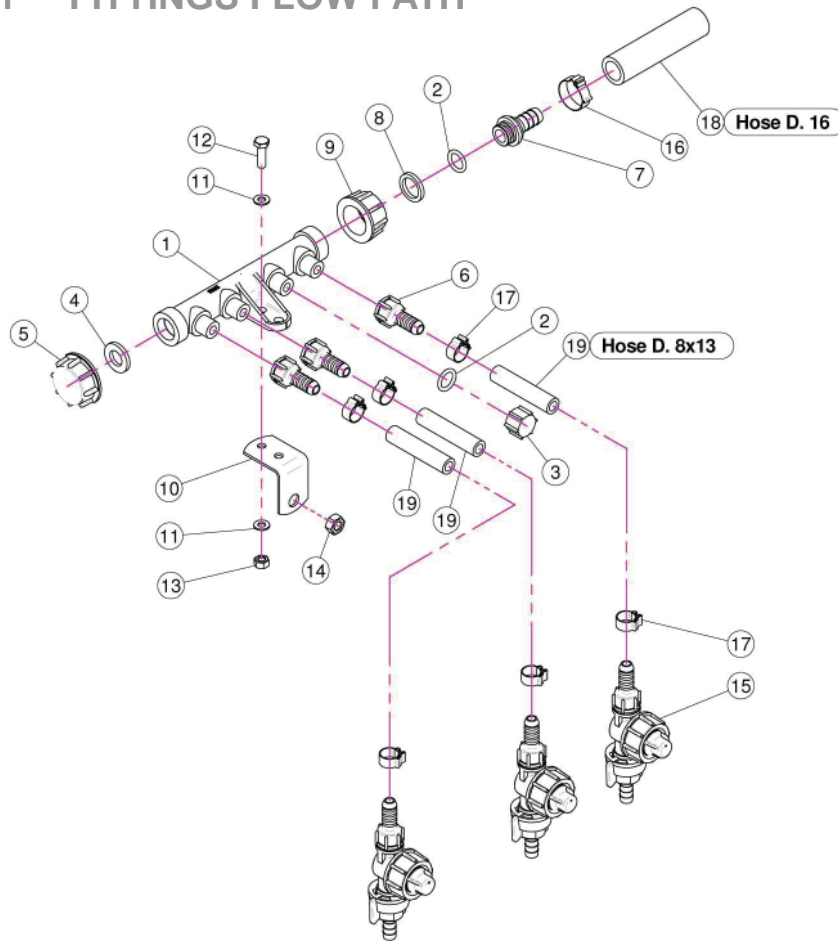

REF #	QTY.	PART NO.	DESCRIPTION
1	1	02.008.000	Sprayheads Liquid Manifold
2	2	OR.000.117	13.1 x 18.34 x 2.62 O-Ring Gasket
3	1	02.013.000	Plug G 1/4"
4	1	02.030.010	Gasket
5	1	02.182.000	Female 3/4" Cap
6	3	02.007.011	Straight Union R.H. D.11
7	1	02.122.000	D.13 Union
8	1	02.349.000	17 x 23 x 3 Flat Gasket
9	1	00.055.045	3/4" Fly Nut
10	1	20.360.000	Bracket
11	4	RP.006.000	Washer D.6
12	2	TE.006.020T	Screw TE M6 x 20
13	2	D0.06.5588G	Nut M6
14	1	D0.08.5588G	M8 6S Big Lead Nut 5588
15	3	00.226.05C	Complete Anti-drip
16	1	FC.022.5.024	Hose Clamp 22.5 - 24
17	6	FC.014.5.016	Hose Clamp
18	As Req'd	02.211.000	Hose D.16 (Per Foot)
19	As Req'd	02.217.000	Hose D.8 x 13 (Per Foot)

4 LIQUID FLOW PATH

Sec. 02 FITTINGS, LIQUID FLOW PATH

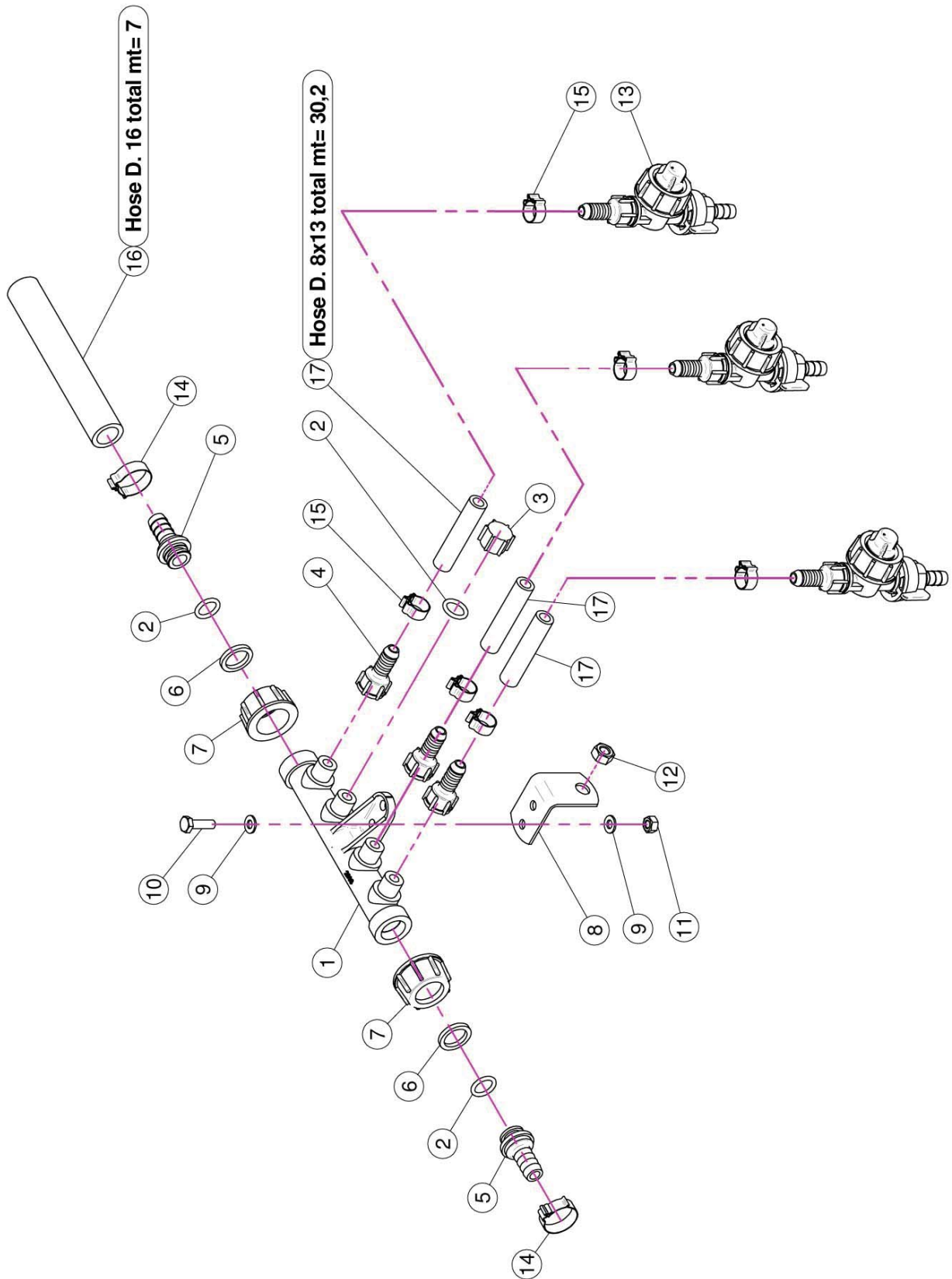

4 LIQUID FLOW PATH

Sec. 02 FITTINGS, LIQUID FLOW PATH

<u>REF #</u>	<u>QTY.</u>	<u>PART NO.</u>	<u>DESCRIPTION</u>
1	1	02.008.000	Sprayheads Liquid Manifold
2	3	OR.000.117	13.1 x 18.34 x 2.62 O-Ring Gasket
3	1	02.013.000	Plug G 1/4"
4	3	02.007.011	Straight Union R.H. D.11
5	2	02.122.000	D.13 Union
6	2	02.349.000	17 x 23 x 3 Flat Gasket
7	2	00.055.045	3/4" Fly Nut
8	1	20.360.000	Bracket
9	4	RP.006.000	Washer D.6
10	2	TE.006.020T	Screw TE M6 x 20
11	2	D0.06.5588G	Nut M6
12	1	D0.08.5588G	M8 6S Big Lead Nut 5588
13	3	00.226.05C	Complete Anti-drip
14	2	FC.022.5.024	Hose Clamp 22.5 - 24
15	4	FC.014.5.016	Hose Clamp
16	As Req'd	02.211.000	Hose D.16 (Per Foot)
17	As Req'd	02.217.000	Hose D.8 x 13 (Per Foot)

4 LIQUID FLOW PATH

Sec. 03 FITTINGS, LIQUID FLOW PATH

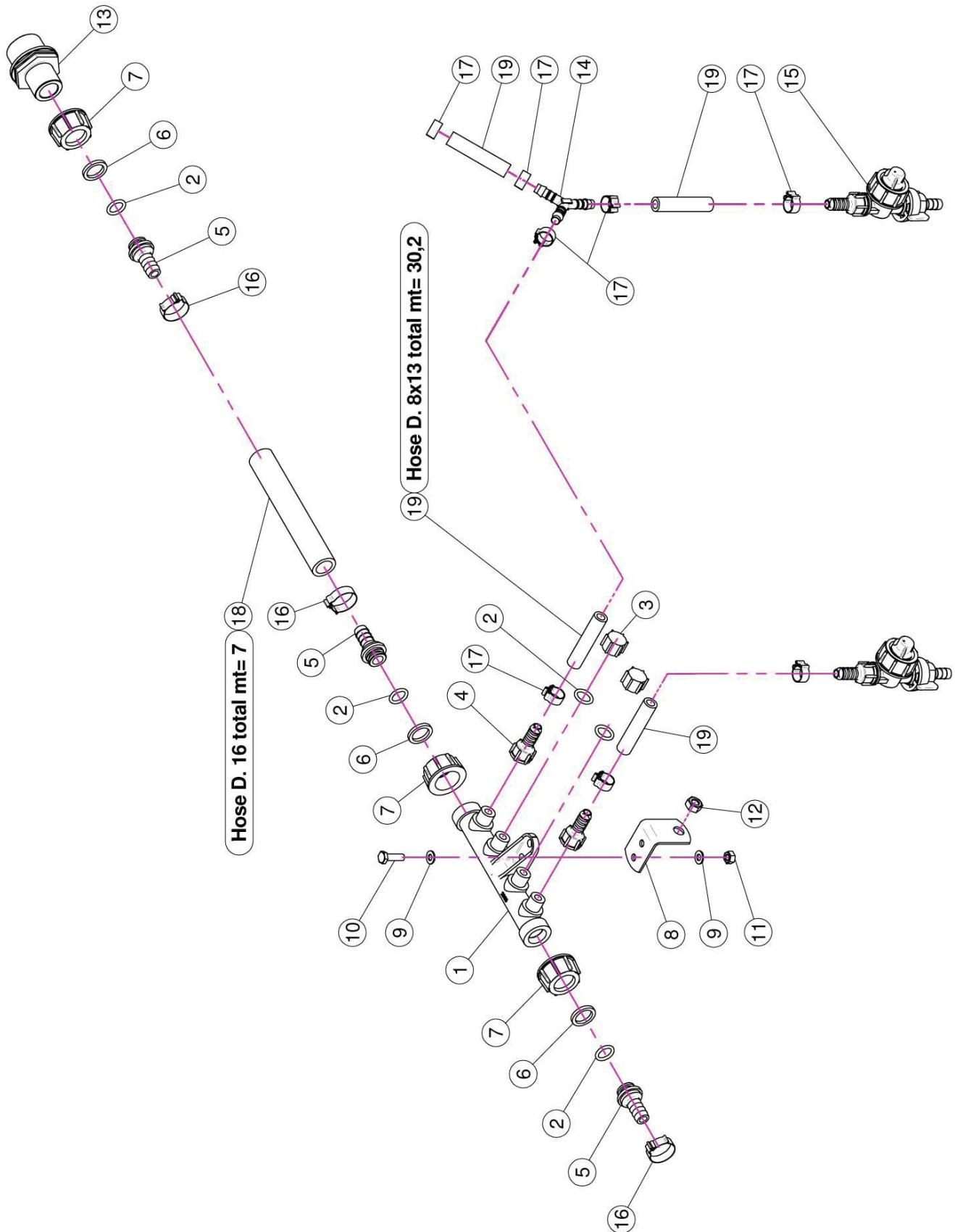

4 LIQUID FLOW PATH

Sec. 03 FITTINGS, LIQUID FLOW PATH

<u>REF #</u>	<u>QTY.</u>	<u>PART NO.</u>	<u>DESCRIPTION</u>
1	1	02.008.000	Sprayheads Liquid Manifold
2	5	OR.000.117	13.1 x 18.34 x 2.62 O-Ring Gasket
3	2	02.013.000	Plug G 1/4"
4	2	02.007.011	Straight Union R.H. D.11
5	3	02.122.000	D.13 Union
6	3	02.349.000	17 x 23 x 3 Flat Gasket
7	3	00.055.045	3/4" Fly Nut
8	1	20.360.000	Bracket
9	4	RP.006.000	Washer D.6
10	2	TE.006.020T	Screw TE M6 x 20
11	2	D0.06.5588G	Nut M6
12	1	D0.08.5588G	M8 6S Big Lead Nut 5588
13	1	02.293.000	1" M - 3/4" M Reducer Nipple
14	1	02.077.010	Y Fitting
15	2	00.226.05C	Complete Anti-drip
16	3	FC.022.5.024	Hose Clamp 22.5 - 24
17	8	FC.014.5.016	Hose Clamp
18	As Req'd	02.211.000	Hose D.16 (Per Foot)
19	As Req'd	02.217.000	Hose D.8 x 13 (Per Foot)

4 LIQUID FLOW PATH

Sec. 04 COMPLETE ANTI-DRIP NOZZLE ASSEMBLY (00.226.105C)

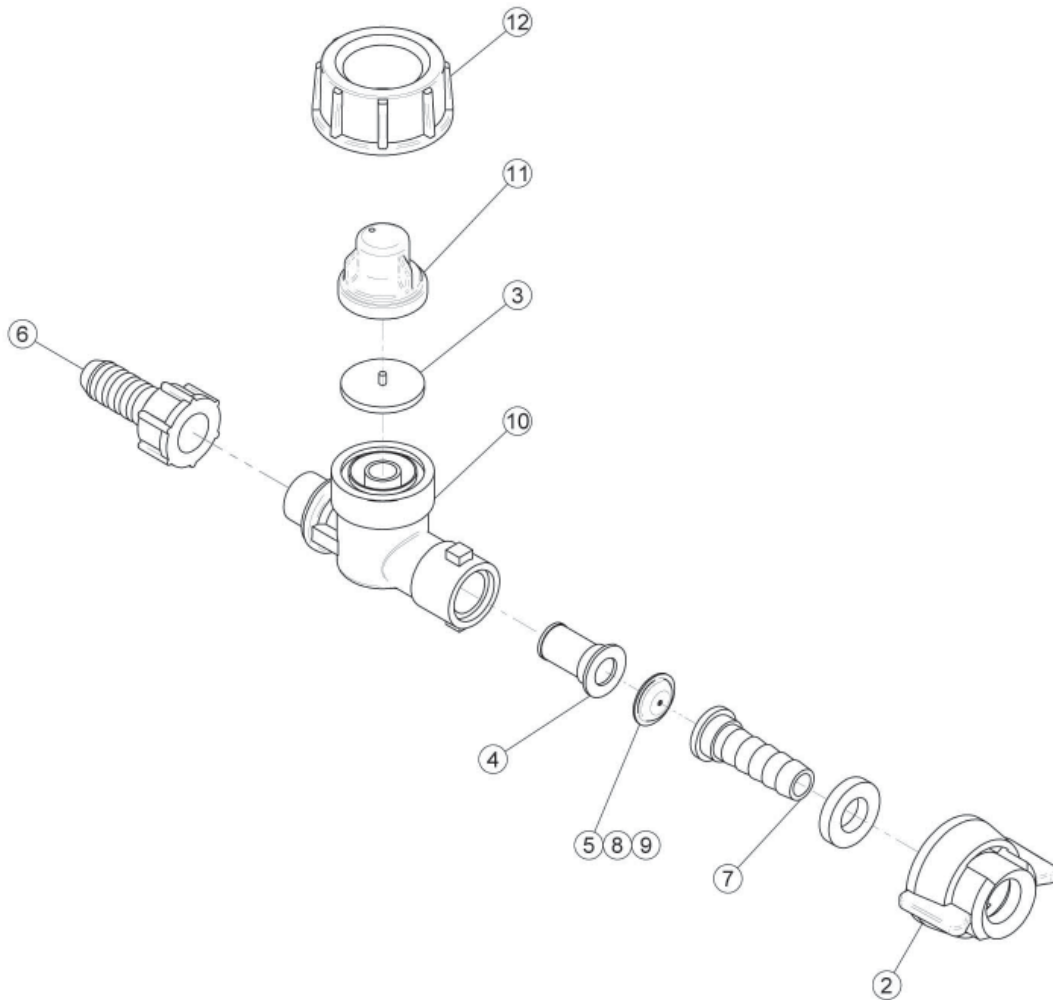

<u>REF #</u>	<u>QTY.</u>	<u>PART NO.</u>	<u>DESCRIPTION</u>
2	1	00.226.142	Fly Nut + Gasket
3	1	00.226.010	Viton Gasket
4	1	02.311.010	50 Mesh Filter
5	1	02.305.012	D 1.2 Stainless Steel Disc (Standard)
6	1	02.007.011	Straight Union R.H. Ø11
7	1	02.379.020	Straight Union R.H. 10
8	1	02.305.010	D 1 Stainless Steel Disc
9	1	02.305.015	D 1.5 Stainless Steel Disc
10	1	00.226.041.A	Anti-Drip Body
11	1	00.226.041.C	Gasket
12	1	00.226.045	3/4" Fly Nut

5 LIMITED WARRANTY



GEARMORE, INC., warrants each new Gearmore product to be free from defects in material and workmanship for a period of twelve (12) months from date of purchase to the original purchaser. This warranty shall not apply to implements or parts that have been subject to misuse, negligence, accident, or that have been altered in any way.

Our obligation shall be limited to repairing or replacement of any part, provided that such part is returned within thirty (30) days from date of failure to Gearmore through the dealer from whom the purchase was made, transportation charges prepaid.

This warranty shall not be interpreted to render us liable for injury or damages of any kind or nature, direct, consequential or contingent, to person or property. This warranty does not extend to loss of crops, loss because of delay in harvesting or any other expenses, for any other reasons.

Gearmore in no way warrants engines, tires, or other trade accessories, since these items are warranted separately by these respective manufacturers.

Gearmore reserves the right to make improvements in design or changes in specification at any time, without incurring any obligations to owners or units previously sold.

GEARMORE, INC.
13477 Benson Ave.
Chino, CA 91710

Always refer to and heed machine operating warning decals on machine.

*To validate the warranty on this product, please log-in to our website - www.gearmore.com.
You will find "warranty registration" listed at the top of our homepage.*