

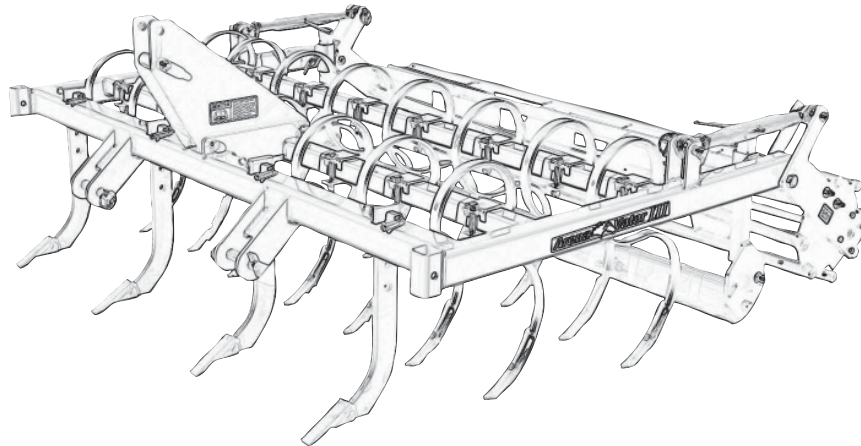

ARENA-VATOR III



Assembly/Operator's/Parts Manual
For Models
AV3-4, AV3-5, AV3-6,
AV3-7, & AV3-8

June 2020

TABLE OF CONTENTS

SECTION	DESCRIPTION	PAGE
1	Introduction	1
1.1	Serial Number Location	1
2	Safety.....	2
2.1	General Safety	3
2.2	Equipment Safety Guidelines	4
2.3	Safety Training	5
2.4	Safety Signs	5
2.5	Preparation	6
2.6	Operating Safety	7
2.7	Transport Safety	8
2.8	Storage Safety	8
2.9	Maintenance Safety	8
3	Safety Sign Locations.....	9
4	Operation	10
4.1	To the New Operator or Owner	10
4.2	Machine Components	11
4.3	Machine Break-In	11
4.4	Pre-Operation Checklist.....	11
4.5	Field Operation.....	12 - 15
4.6	Transporting	16
4.7	Storage	16
5	Service & Maintenance.....	17
5.1	Service	17
5.1.1	Fluids and Lubricants	17
5.1.2	Greasing	17
5.1.3	Servicing Intervals	18
5.1.4	Service Record.....	18
6	Trouble Shooting.....	19
7	Assembly.....	20 - 21
8	Specifications	22
8.1	Mechanical	22
8.2	Bolt Torque.....	22
9	Parts Reference	23
9.1	Arena-vatorIII Drawing	23
9.2	Parts List.....	24 - 27
9.3	AV3-PH Pull Hitch Assembly	28
9.4	Optional Features.....	29
10	Limited Warranty.....	30

1 INTRODUCTION

Congratulations on your choice of an Arena-VatorIII to complement your conditioning and leveling operation. This equipment has been designed and manufactured to meet the needs of a discriminating buyer for the efficient conditioning and leveling of land.

Safe, efficient and trouble free operation of your Arena-vatorIII requires that you and anyone else who will be operating or maintaining the machine, read and understand the Safety, Operation, Maintenance and Troubleshooting information contained within the Operator's Manual.

This manual covers the Arena-VatorIII Models AV3-4, AV3-5, AV3-6, AV3-7, & AV3-8. Differences are explained where appropriate. Use the Table of Contents as a guide to locate required information.

Keep this manual handy for frequent reference and to pass on to new operators or owners. Call your Gearmore dealer or distributor if you need assistance, information or additional copies of the manuals.

OPERATOR ORIENTATION - The directions left, right, front and rear, as mentioned throughout this manual, are as seen from the driver's seat and facing in the direction of travel.

1.1 SERIAL NUMBER LOCATION

Always give your dealer the serial number of your Arena-vatorIII when ordering parts or requesting service or other information.

The serial number plate is located on the top link plate. Please mark the number in the space provided for easy reference.

DATE OF PURCHASE: _____

MODEL NUMBER: _____

SERIAL NUMBER: _____

2 SAFETY

SAFETY ALERT SYMBOL

This Safety Alert symbol means **ATTENTION! BECOME ALERT! YOUR SAFETY IS INVOLVED!**



The Safety Alert symbol identifies important safety messages on the Twinstar Basket Rake and in the manual. When you see this symbol, be alert to the possibility of personal injury or death. Follow the instructions in the safety message.

Why is SAFETY important to you?

3 Big Reasons

Accidents Disable and Kill
Accidents Cost
Accidents Can Be Avoided

SIGNAL WORDS:

Note the use of the signal words **DANGER**, **WARNING** and **CAUTION** with the safety messages. The appropriate signal word for each message has been selected using the following guide-lines:

SI NO LEE INGLES, PIDA AYUDA A AIGUIEN QUE SI LO LEA PARA QUE LE TRADUZCA LAS MIDIDAS DE SEGURIDAD.

DANGER - Indicates an imminently hazardous situation that, if not avoided, will result in death or serious injury. This signal word is to be limited to the most extreme situations typically for machine components which, for functional purposes, cannot be guarded.

WARNING - Indicates a potentially hazardous situation that, if not avoided, could result in death or serious injury, and includes hazards that are exposed when guards are removed. It may also be used to alert against unsafe practices.

CAUTION - Indicates a potentially hazardous situation that, if not avoided, may result in minor or moderate injury. It may also be used to alert against unsafe practices.

If you have any questions not answered in this manual or require additional copies or the manual is damaged, please contact your dealer or GEARMORE INC., 13477 Benson Avenue, Chino, CA 91710
Phone: 909.548.4848 - Fax: 909.548.4747 sales@gearmore.com

2.1 GENERAL SAFETY

YOU are responsible for the **SAFE** operation and maintenance of your Arena-vatorIII. **YOU** must ensure that you and anyone else who is going to operate, maintain or work around the Arena-vatorIII be familiar with the operating and maintenance procedures and related **SAFETY** information contained in this manual. This manual will take you step-by-step through your working day and alerts you to all good safety practices that should be adhered to while operating the Arena-vatorIII.

Remember, **YOU** are the key to safety. Good safety practices **NOT** only protect you, but also the people around you. Make these practices a working part of your safety program. Be certain that **EVERYONE** operating this equipment is familiar with the recommended operating and maintenance procedures and follows all the safety precautions. Most accidents can be prevented. Do not risk injury or death by ignoring good safety practices.

- Arena-vatorIII owners must give operating instructions to operators or employees before allowing them to operate the machine, and at least annually there after per OSHA (Occupational Safety and Health Administration) regulation 1928.57.
- The most important safety feature on this equipment is a **SAFE** operator. It is the operator's responsibility to read and understand **ALL** Safety and Operating instructions in the manual and to follow these. Most accidents can be avoided.
- A person who has not read and understood all operating and safety instructions is not qualified to operate the machine. An untrained operator exposes himself and bystanders to possible serious injury or death.
- **DO NOT** modify the equipment in any way. Unauthorized modification may impair the function and/or safety and could affect the life of the equipment.
- **Think SAFETY! Work SAFELY!**

1. Read and understand the Operator's Manual and all safety signs before operating, maintaining adjusting or unplugging the Arena-vatorIII.



2. Have a first-aid kit available for use should the need arise and know how to use it.



3. Have a fire extinguisher available for use should the need arise and know how to use it.



4. Wear appropriate protective gear. This list includes but is not limited to:

- A hard hat
- Protective shoes with slip resistant soles
- Protective goggles, glasses or face shield
- Heavy gloves
- Protective clothing

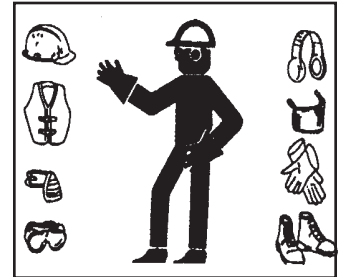

5. Install and secure all guards before starting.

6. **DO NOT** allow riders.

7. Wear suitable ear protection for prolonged exposure to excessive noise.



8. Place all controls in neutral, stop tractor engine, set park brake, remove ignition key and wait for all moving parts to stop before servicing, adjusting, repairing, or unplugging.

9. Clear the area of people, especially small children, before starting.

10. Review safety related items annually with all personnel who will be operating or maintaining the Arena-vatorIII.

2.2 EQUIPMENT SAFETY GUIDELINES

Safety of the operator and bystanders is one of the main concerns in designing and developing a machine. However, every year many accidents occur which could have been avoided by a few seconds of thought and a more careful approach to handling equipment. You, the operator, can avoid many accidents by observing the following precautions in this section. To avoid personal injury or death, study the following precautions and insist those working with you, or for you, follow them.

- In order to provide a better view, certain photographs or illustrations in this manual may show an assembly with a safety shield removed. However, equipment should **never** be operated in this condition. Keep all shields in place. If shield removal becomes necessary for repairs, replace the shield prior to use.
- Replace any safety sign or instruction sign that is not readable or is missing. Location of such safety signs is indicated in this manual.
- **NEVER** use alcoholic beverages or drugs which can hinder alertness or coordination while operating this equipment. Consult your doctor about operating this machine while taking prescription medications.
- **Under no circumstances should young children be allowed to work with this equipment. Do not allow persons to operate or assemble this unit until they have read this manual and have developed a thorough understanding of the safety precautions and of how it works.** Review the safety instructions with all users annually.

- This equipment is dangerous to children and persons unfamiliar with its operation. The operator should be a responsible, properly trained and physically able person familiar with farm machinery and trained in this equipment's operations. If the elderly are assisting with farm work, their physical limitations need to be recognized and accommodated.
- Use a tractor equipped with a Roll Over Protective Structure (ROPS) and a seat belt.
- **NEVER** exceed the limits of a piece of machinery. If its ability to do a job, or to do so safely, is in question - **DON'T TRY IT.**
- Do not modify the equipment in any way. Unauthorized modification may impair the function and/or safety and could affect the life of the equipment.

In addition to the design and configuration of this implement, including Safety Signs and Safety Equipment, hazard control and accident prevention are dependent upon the awareness, concern, prudence and proper training of personnel involved in the operation, transport, maintenance and storage of the machine. Refer also to Safety Messages and operation instruction in each of the appropriate sections of the tractor and machine manuals. Pay close attention to the Safety Signs affixed to the tractor and the machine.

Think SAFETY! Work SAFELY!

2.3 SAFETY TRAINING

Safety is a primary concern in the design and manufacture of our products. Unfortunately, our efforts to provide safe equipment can be wiped out by a single careless act of an operator or bystander.

In addition to the design and configuration of equipment, hazard control and accident prevention are dependent upon the awareness, concern, prudence and proper training of personnel involved in the operation, transport, maintenance and storage of this equipment.

It has been said, "***The best safety feature is an informed, careful operator.***" We ask you to be that kind of an operator. It is the operator's responsibility to read and understand ALL Safety and Operating instructions in the manual and to follow these. Accidents can be avoided.



Working with unfamiliar equipment can lead to careless injuries. Read this manual, and the manual for your tractor, before assembly or operating, to acquaint yourself with the machines. If this machine is used by any person other than yourself, or is loaned or rented, it is the machine owner's responsibility to make certain that the operator, prior to operating:

- a. Reads and understands the operator's manuals.
- b. Is instructed in safe and proper use.

Know your controls and how to stop tractor, engine and machine quickly in an emergency. Read this manual and the one provided with your tractor.

Train all new personnel and review instructions frequently with existing workers. Be certain only a properly trained and physically able person will operate the machinery. A person who has not read and understood all operating and safety instructions is not qualified to operate the machine. An untrained operator exposes himself and bystanders to possible serious injury or death. If the elderly are assisting with farm work, their physical limitations need to be recognized and accommodated.

2.4 SAFETY SIGNS

1. Keep safety signs clean and legible at all times.
2. Replace safety signs that are missing or have become illegible.
3. Replaced parts that displayed a safety sign should also display the current sign.
4. Safety signs are available from your authorized dealer or from Gearmore.

How To Install Safety Signs:

- Be sure that the installation area is clean and dry.
- Be sure temperature is above 50° F (10° C).
- Determine exact position before you remove the backing paper. (*See Section 3*)
- Remove the smallest portion of the split backing paper.
- Align the sign over the specified area and carefully press the small portion with the exposed sticky backing in place.
- Slowly peel back the remaining paper and carefully smooth the remaining portion of the sign in place.
- Small air pockets can be pierced with a pin and smoothed out using the piece of sign backing paper.

2.5 PREPARATION

1. Never operate the tractor and machine until you have read and completely understand this manual, the Tractor Operator's Manual and each of the Safety Messages found on the safety signs on the tractor and machine.

2. Personal protection equipment, including hard hat, safety glasses, safety shoes and gloves are recommended during assembly, installation, operation, adjustment, maintaining, repairing, removal or moving the implement. **DO NOT** allow long hair, loose fitting clothing or jewelry to be around equipment.

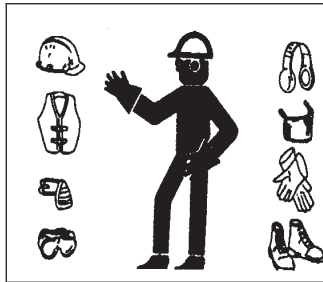

3. **PROLONGED EXPOSURE TO LOUD NOISE MAY CAUSE PERMANENT HEARING LOSS!**

Tractors with or without equipment attached can often be noisy enough to cause permanent, partial hearing loss. We recommend that you wear hearing protection on a full-time basis if the noise in the Operator's position exceeds 80db. Noise over 85db on a long-term basis can cause severe hearing loss. Noise over 90db adjacent to the Operator over a long-term basis may cause permanent, total hearing loss.



NOTE: Hearing loss from loud noise (from tractors, chain saws, radios, and other such sources close to the ear) is cumulative over a lifetime without hope of natural recovery.

4. Operate the machine only with a tractor equipped with an approved Roll-Over Protective Structure (ROPS). Always wear your seat belt. Serious injury or even death could result from falling off the tractor --- particularly during a turn-over when the operator could be pinned under the ROPS or the tractor.
5. Clear working area of stones, branches or hidden obstacles that might be hooked or snagged, causing injury or damage.
6. Operate only in daylight or good artificial light.
7. Be sure machine is properly mounted, adjusted and in good operating condition.
8. Ensure that all safety shielding and safety signs are properly installed and in good condition.



2.6 OPERATING SAFETY

Please remember it is important that you read and heed the safety signs on the Arena-vatorIII. Clean or replace all safety signs if they cannot be clearly read and understood. They are there for your safety, as well as the safety of others. The safe use of this machine is strictly up to you, the operator.

All things with moving parts are potentially hazardous. There is no substitute for a cautious, safe-minded operator who recognizes potential hazards and follows reasonable safety practices. The manufacturer has designed this Arena-vatorIII to be used with all its safety equipment properly attached to minimize the chance of accidents. Study this manual to make sure you have all safety equipment attached.

If a safety shield or guard is removed for any reason, it must be replaced before the machine is again operated.

When the use of hand tools is required to perform any part of assembly, installation, adjustment, maintaining, repairing, removal, or moving, be sure the tools used are designed and recommended by the tool manufacturer for that specific task.

Personal protection equipment including hard hat, safety glasses, safety shoes, and gloves are recommended during assembly, installation, operation, adjustment, maintaining, repairing, removal, or moving. Do not allow long hair, loose fitting clothing, or jewelry to be around moving parts.

Always use two people to handle heavy, unwieldy components during assembly, installation, removal, or moving.

Never place any part of your body where it would be in danger if movement should occur during assembly, installation, operation, maintaining, repairing, removal, or moving.

Never place yourself between the tractor and machine while implement is in operation.

Do not walk or work under a raised machine or attachment unless it is securely blocked or held in position. Do not depend on the tractor hydraulic system to hold the machine or attachment in place.

A heavy load can cause instability of the tractor. Use extreme care during travel. Slow down on turns and watch out for bumps. The tractor may need front counterweights to counterbalance the weight of the machine.

Never use alcoholic beverages or drugs, which can hinder alertness or coordination, while operating this equipment. Consult your doctor about operating this machine while taking prescription medications.

Do not allow riders on the machine or tractor at any time. There is no safe place for any riders.

Before you operate the machine, check over all pins, bolts and connections to be sure all are securely in place. Replace any damaged or worn parts immediately.

Do not allow anyone who is not familiar with the safety rules and operation instructions to use this machine.

Never allow children to operate or be around this machine.

Use stabilizer bars, adjustable sway chains, or sway blocks on the tractor lift arms to keep the machine from swinging side to side. Adjust as tightly as practical for best performance.

Clear the work area of objects which might be picked up and snagged or entangled in the machine.

Keep hands, feet, hair, jewelry, and clothing away from all moving and/or rotating parts.

2.7 TRANSPORT SAFETY

1. Comply with state and local laws governing highway safety and movement of farm machinery on public roads.
2. The use of flashing amber lights is acceptable in most localities. However, some localities prohibit their use. Local laws should be checked for all highway lighting and marking requirements.
3. At all times, when driving the tractor and equipment on the road or highway under 20 mph (32 kph) use flashing amber warning lights and a slow moving vehicle (SMV) identification emblem. Do not exceed 20 mph (32 kph). Reduce speed on rough roads and surfaces.
4. Plan your route to avoid heavy traffic.
5. Always install transport locks, pins, or brackets before transporting.
6. Do not drink and drive.
7. Be a safe and courteous driver. Always yield to oncoming traffic in all situations, including narrow bridges, intersections, etc. Watch for traffic when operating near or crossing roadways.
8. Turn into curves or go up or down hills only at a low speed and at a gradual steering angle. Make certain that at least 20% of the tractor's weight is on the front wheels to maintain safe steering. Slow down on rough or uneven surfaces.
9. Never allow riders on either tractor or machine.

2.8 STORAGE SAFETY

1. Store the unit in an area away from human activity.
2. Do not permit children to play on or around the stored machine.
3. Store the unit in a dry, level area. Support the frame with planks if required.

2.9 MAINTENANCE SAFETY

1. Good maintenance is your responsibility. Poor maintenance is an invitation to trouble.
2. Follow good shop practices.
 - Keep service area clean and dry.
 - Be sure electrical outlets and tools are properly grounded.
 - Use adequate light for the job at hand.
3. Make sure there is plenty of ventilation. Never operate the engine in a closed building. The exhaust fumes may cause asphyxiation.
4. Before working on this machine, shut off the engine, set the brakes, and remove the ignition key.
5. Never work under equipment unless it is blocked securely.
6. Use personal protection devices such as eye, hand and hearing protectors, when performing any service or maintenance work.
7. Where replacement parts are necessary for periodic maintenance and servicing, genuine factory replacement parts **must** be used to restore your equipment to original specifications. The manufacturer will not be responsible for injuries or damages caused by use of unapproved parts and/or accessories.
8. A fire extinguisher and first aid kit should be kept readily accessible while performing maintenance on this equipment

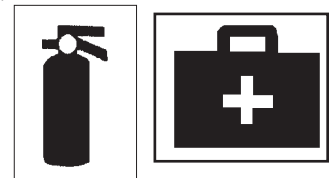
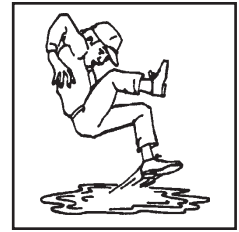

9. Periodically tighten all bolts, nuts and screws and check that all cotter pins are properly installed to ensure unit is in a safe condition.
10. When completing a maintenance or service function, make sure all safety shields and devices are installed before placing unit in service.

3 SAFETY SIGN LOCATION

The types of safety signs and locations on the equipment are shown in the illustration below. Good safety requires that you familiarize yourself with the various safety signs, the type of warning and the area, or particular function related to that area, that requires your SAFETY AWARENESS.



A

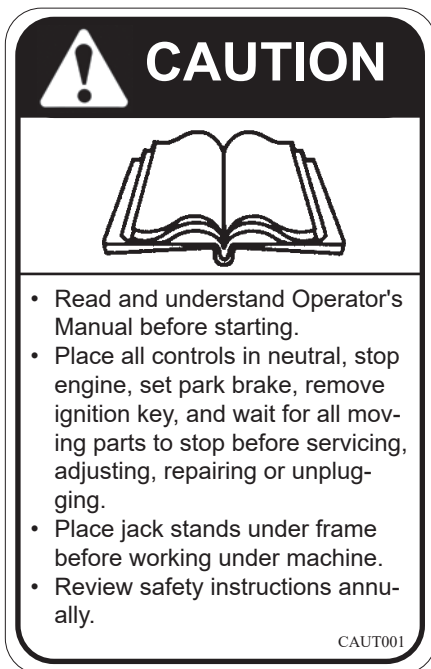

REMEMBER - If safety signs have been damaged, removed, become illegible or parts replaced without signs, new signs must be applied. New signs are available from your authorized dealer.

4 OPERATION



OPERATING SAFETY

1. Read and understand the Operator's Manual and all safety signs before operating, servicing, adjusting, repairing, or unplugging.
2. Do not allow riders.
3. Install and secure all guards and shields before starting or operating.
4. Keep hands, feet, hair, and clothing away from moving parts.
5. Place all controls in neutral, stop tractor engine, set park brake, remove ignition key and wait for all moving parts to stop before servicing, adjusting, repairing, or unplugging.
6. Place all tractor and machine controls in neutral before starting.
7. Never start or operate machine unless sitting on tractor seat.
8. Clear the area of bystanders, especially small children, before starting.
9. Clean reflectors, SMV and lights before transporting.
10. Use hazard flashers on tractor when transporting.
11. Do not put hands or feet under machine while tractor engine is running.
12. Review safety instructions with all operators annually.

4.1 TO THE NEW OPERATOR OR OWNER

The Arena-vatorIII is designed as light duty tillage tool for working up, leveling, packing, and conditioning the soil and surface. Be familiar with the machine before starting.

It is the responsibility of the owner or operator to read this manual and to train all other operators before they start working with the machine. Follow all safety instructions exactly. Safety is everyone's business. By following recommended procedures, a safe working environment is provided for the operator, bystanders and the area around the worksite. Untrained operators are not qualified to operate the machine.

Many features incorporated into this machine are the result of suggestions made by customers like you. Read this manual carefully to learn how to operate the machine safely and how to set it to provide maximum field efficiency. By following the operating instructions in conjunction with a good maintenance program, your Arena-vatorIII will provide many years of trouble free service.

4.2 MACHINE COMPONENTS

The Arena-vatorIII consists of a cultivator assembly up front, a leveling blade and a rear roller. It will work the soil, level it, pack and condition the surface in one pass.

- A CULTIVATOR FRAME
- B REVERSIBLE POINTS/SHOVELS
- C TINES
- D LEVELING BLADE
- E ROLLER

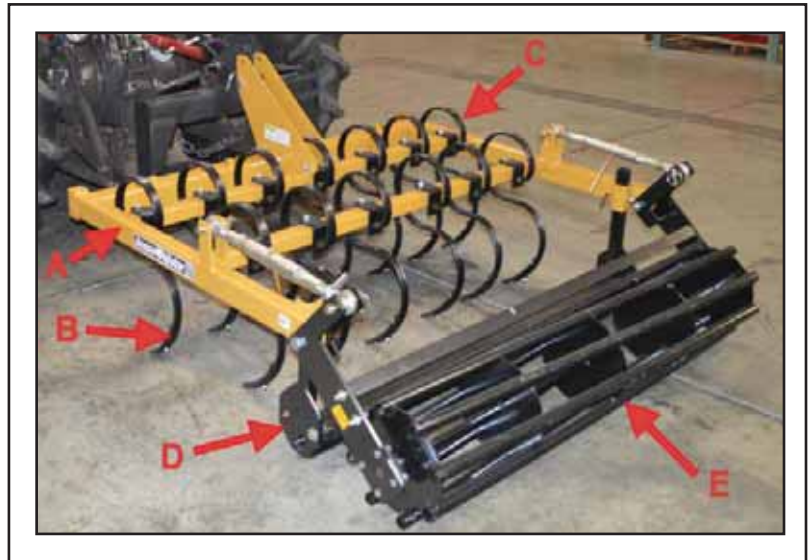

Fig. 1- Machine Components

4.3 MACHINE BREAK-IN

Although there are no operational restrictions on the Arena-vatorIII when used for the first time, it is recommended that the following mechanical items be checked:

A. After Operating For 1 and 5 Hours:

1. Check all nuts, bolts and other fasteners. Tighten to their specified torque level.
2. Check that the tines are in good condition.
3. Then go to the regular service schedule as defined in Section 5.

4.4 PRE-OPERATION CHECKLIST

Efficient and safe operation of the Arena-vatorI-II requires that each operator reads and understands the operating procedures and all related safety precautions outlined in this section. A pre-operation checklist is provided for the operator. It is important for both the personal safety and maintaining the good mechanical condition of the Arena-vatorIII that this checklist is followed.

Before operating the machine and each time thereafter, the following areas should be checked off:

- √ Use only a small Agricultural tractor of the recommended horsepower on the machine.
- √ Check that the machine is properly attached to the tractor. Be sure retainers are used on the mounting pins.
- √ Be sure extra weights are mounted on the front of the tractor if required.
- √ Check the tines/shovels/blade/roller. Be sure they are not damaged or broken and are not badly worn. Repair or replace as required.
- √ Check for entangled material. Remove this material.

4.5 FIELD OPERATION



OPERATING SAFETY

1. Read and understand the Operator's Manual and all safety signs before operating, servicing, adjusting, repairing, or unplugging.
2. Do not allow riders.
3. Install and secure all guards and shields before starting or operating.
4. Keep hands, feet, hair, and clothing away from moving parts.
5. Place all controls in neutral, stop tractor engine, set park brake, remove ignition key and wait for all moving parts to stop before servicing, adjusting, repairing, or unplugging.
6. Place all tractor and machine controls in neutral before starting.
7. Never start or operate machine unless sitting on tractor seat.
8. Clear the area of bystanders, especially small children, before starting.
9. Clean reflectors, SMV and lights before transporting.
10. Use hazard flashers on tractor when transporting.
11. Do not put hands or feet under machine while tractor engine is running.

The Arena-vatorIII's are designed as a light duty tillage tool used to work up horse arenas and tracks, level them, and pack/condition the surface. However the operator has the responsibility of being familiar with all operating and safety procedures and following them.

Each operator should review this section of the manual at the start of the season and as often as required to be familiar with the machine. When using, follow this procedure:

1. Review and follow the Pre-Operation Checklist.
2. Attach the tractor to the machine:
 - a. Move the lift arms and slide the balls over the mounting pins. Install the retainers.
 - b. Attach the top link to the mast bracket. Install the retainer.

IMPORTANT

Do not use on a tractor of more than the recommended horsepower. Larger tractors can overload and bend the frame or tines, blades, and the roller.

- c. Always engage the anti-sway components on each lift arm to keep the unit from moving from side-to-side during operation.



Fig. 2 - Attached

3. Horsepower/3-Point Hitch:

Each Arena-vatorIII model is designed to be used on a tractor of a certain horsepower range and 3-point hitch size as specified in Table 1. Do not exceed the recommended horsepower range to prevent overloading the structural components. Always use the appropriate sized mounting pins when hooking up to a tractor.

4. Before going to the working area re-view Section 4.6 Transporting.
5. Drive to the working area and stop in a level area.
6. Position the machine about 2" above the ground. Be sure the roller is off the ground.
7. **Set the Machine:**

a. Level the Frame:

Use the screw jack on the right lift arm to level the frame from side-to-side.

b. Frame Angle:

Use the turnbuckle on the top link to set the frame angle. Start by using the top link to set the frame level with the ground. Then, extend the top link by turning the turnbuckle another full turn. This will lower the roller and allow the frame to follow the contours of the ground through the movable mast bracket during operation.

c. 3-Point Hitch:

Set the 3-point hitch on the tractor into the "float" mode to allow the frame/machine to follow the contour of the ground. This will allow all components to work the soil evenly.

TABLE 1 HORSEPOWER VS. MODEL

MODEL	SHANKS	HITCH CATEGORY	HORSEPOWER RANGE
AV3-4	11	Cat. 1	18 to 32
AV3-5	13	Cat. 1	18 to 32
AV3-6	15	Cat. 1	22 to 39
AV3-7	17	Cat. 1	26 to 47
AV3-8	19	Cat. 1 & 2	30 to 53

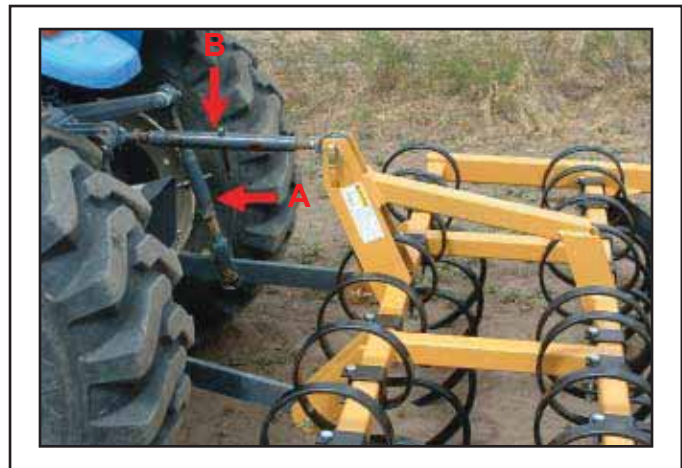

Fig. 3 - Leveling

d. Beveled Blade Position:

The beveled blade is located directly behind the cultivator section and is used to spread and level the soil loosened by the cultivator.

A good starting position would be in the second hole on the strap. This will place the blade slightly above the cultivator shovel depth position. Lower if the blade is not distributing or moving the soil along the width of the cut. Raise if a lot of soil is going over the top of the blade. Set both ends of the blade in the same hole.

e. Roller:

The roller is designed with adjustable top links to allow the operator to set the depth of the roller during operation. The best results are obtained when the roller is set slightly higher than the depth of the cultivator shovels. It should pack, condition and compress the soil as the machine moves across the working area.

The roller adjustment top links should be equal length.

Observe the quality of the job when starting to work. Raise the roller if the cultivator is not able to penetrate the surface and work up the soil. Lower if the soil is not being compressed.

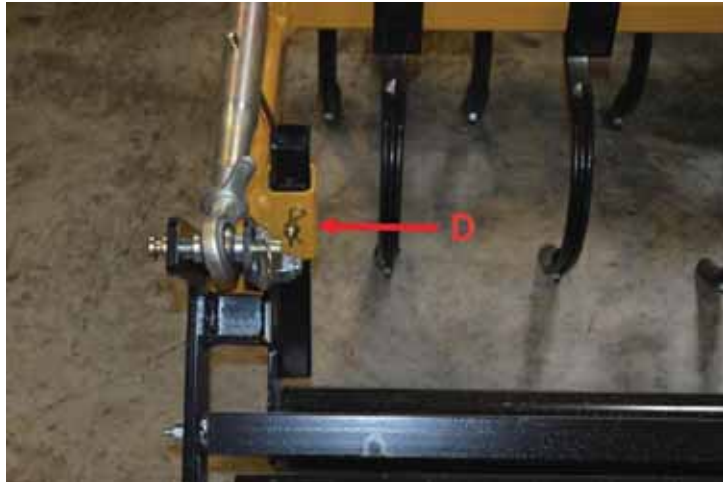

Blade Depth



Roller Height



Working

Fig. 4 - Blade/Roller

8. Drive over the area to be leveled.

9. Ground Speed:

Although the Arena-vatorIII can be operated at any speed, it is recommended that slow speeds be used. High speeds can lead to skipping by the tines and an uneven job. Two to four mph will give the best results. the operator will have to experiment a little to determine the best speed. Use the type of job being done as a guide.

10. Depth:

The machine is designed as a light to medium duty tillage tool for working up, leveling, conditioning, and compacting arenas and tracks. The best results are obtained when the cultivator works up the soil 2 to 5 inches deep. As the blade smooths and levels the worked up soil, it is distributed across the working area. The mulcher roller can then condition and compact the soil.



Fig. 5 - Field

Lower the blade and roller to raise the cultivator if the soil is soft and large amounts of soil goes over the blade. Raise the blade if the soil is hard and the shovels/tines need to work up the soil more.

11. Operating Hints:

- a. Use the weight of the machine to push the tines into the ground. Add no more than 100 lbs. to the frame when the ground is hard or deeply rutted. Do not add more weight and push the tines too far into the ground and damage the frame.
- b. Use the amount of soil ahead of the blade as a guide to how the machine is functioning. There should always be a nominal amount of soil coming over the blade. This will insure that the soil is moved across the width of the machine.
- c. In severely compacted or deeply rutted conditions, it is recommended that more than one pass be made to level, condition, and compact the soil.

4.6 TRANSPORTING



TRANSPORT SAFETY

1. Make sure you are in compliance with all local regulations regarding transporting equipment on public roads and highways.
2. Make sure the SMV (Slow Moving Vehicle) emblem and all the lights and reflectors that are required by the local highway and transport authorities are in place, are clean and can be seen clearly by all overtaking and oncoming traffic.
3. Do not allow anyone to ride on the Arena-vatorIII or tractor during transport.
4. Do not exceed 20 mph (32 kph). Reduce speed on rough roads and surfaces.
5. Use retainers on the mounting pins when attaching.
6. Always use hazard flashers on the tractor when transporting unless prohibited by law.

When transporting the machine, review and follow these instructions:

1. Be sure all bystanders are clear of the machine.
2. Be sure that the machine is securely attached to the tractor and all retainer pins are installed.
3. Be sure you have installed extra weights on the front of the tractor if required.
4. Clean the SMV emblem, lights and reflectors and be sure they are working.
5. Be sure you are in compliance with all applicable lighting and marking regulations when transporting. Check with your local authorities.
6. Be sure your machine can clearly be seen by overtaking and oncoming traffic.
7. Keep to the right and yield the right-of-way to allow faster traffic to pass. Drive on the road shoulder if permitted by law.
8. Do not allow riders.
9. Always use hazard flashers on the tractor when transporting unless prohibited by law.

4.7 STORAGE



STORAGE SAFETY

1. Store the unit in an area away from human activity.
2. Do not permit children to play on or around the stored machine.
3. Store the unit in a dry, level area. Support the frame with planks if required.

After the season's use, the machine should be thoroughly inspected and prepared for storage. Repair or replace any worn or damaged components to prevent any unnecessary down time at the start of next season. To insure a long, trouble free life, this procedure should be followed when preparing the unit for storage:

1. Clear the area of bystanders, especially small children.
2. Thoroughly wash the machine using a pressure washer to remove all dirt, mud, debris and residue.
3. Inspect the tines and pivot for damage or entangled material. Repair or replace damaged parts. Remove all entangled material.
4. Touch up all paint nicks and scratches to prevent rusting.
5. Move to storage area.
6. Select an area that is dry, level and free of debris.
7. Unhook from tractor.
8. If the machine cannot be placed inside, cover with a waterproof tarpaulin and tie securely in place.
9. Store the machine in an area away from human activity.
10. Do not allow children to play on or around the stored machine.

5 SERVICE AND MAINTENANCE



MAINTENANCE SAFETY

1. Follow ALL the operating, maintenance, and safety information in the manual.
2. Support the machine with blocks or safety stands when working beneath it.
3. Follow good shop practices:
 - Keep service area clean and dry.
 - Be sure electrical outlets and tools are properly grounded.
 - Use adequate light for the job at hand.
4. Make sure there is plenty of ventilation. Never operate the engine of the towing vehicle in a closed building. The exhaust fumes may cause asphyxiation.
5. Use only tools, jacks and hoists of sufficient capacity for the job.
6. Make sure all guards are in place and properly secured when maintenance work is completed.
7. Keep hands, feet, hair, and clothing away from moving or rotating parts.
8. Clear the area of bystanders, especially small children, when carrying out any maintenance and repairs or making any adjustments.

5.1 SERVICE

5.1.1 FLUIDS AND LUBRICANTS

1. **Grease:**
Use an SAE multi-purpose high temperature grease with extreme pressure (EP) performance. Also acceptable is an SAE multi-purpose lithium base grease.
2. **Storing Lubricants:**
Your machine can operate at top efficiency only if clean lubricants are used. Use clean containers to handle all lubricants. Store them in an area protected from dust, moisture and other contaminants.

5.1.2 GREASING

Use a Maintenance Checklist to keep a record of all scheduled maintenance.

1. Use a hand-held grease gun for all greasing.
2. Wipe grease fitting with a clean cloth before greasing to avoid injecting dirt and grit.
3. Replace and repair broken fittings immediately.
4. If fittings will not take grease, remove and clean thoroughly. Also clean lubricant passage. Replace fitting if necessary.

5.1.3 SERVICING INTERVALS

The period recommended is based on normal operating conditions. Severe or unusual conditions may require more frequent servicing.

Daily or 10 Hours

- Grease roller bearings (2 locations)

Annually

- Clean machine.



Fig. 6 - Roller Bearings

5.1.4 SERVICE RECORD

See Lubrication and Maintenance sections for details of service. Copy this page to continue record.

ACTION CODE: G = GREASE CL = CLEAN

HOURS SERVICED BY MAINTENANCE												
	DAILY OR 10 HOURS											
G Roller Bearings (2)												
ANNUALLY												
CL Machine												

6 TROUBLE SHOOTING

The Arena-vatorIII consists of a cultivator, blade, and roller to work up, level, and condition soil. It is a simple and reliable system that requires minimal maintenance.

In the following section, we have listed many of the problems, causes and solutions to the problems that you may encounter.

If you encounter a problem that is difficult to solve, even after having read through this trouble shooting section, please call your local dealer or distributor. Before you call, please have this Operator's Manual and the serial number from your Arena-vatorIII ready.

PROBLEM	CAUSE	SOLUTION
Soil isn't being worked up.	Compacted soil.	Raise blade and roller to place more weight on cultivator.
		Add weight to cultivator frame. Do not exceed 100 lbs.
		Make 2 passes.
Tines skip over ground.	Driving too fast.	Slow down.
		Set hitch in "float" mode.
Shovels wore out.		Replace shovels.
Machine skips over the ground.	Compacted soil.	Slow Down.
		Add weight to frame.
		Slow down and make two passes.
Ruts aren't being filled.	Blade too high.	Lower blade.
	Compacted soil.	Add weight to frame and make several passes.

7 ASSEMBLY

The machine is shipped from the factory in a partially disassembled form that allows for easy and convenient shipping.

When preparing for the customer, follow this procedure:

1. Clear the area of bystanders, especially small children.
2. Use 2 men to guide or direct and handle the heavy and bulky components.
3. Use a crane, hoist or forklift of sufficient capacity and stability to handle the components.
4. Attach to the lifting device, remove tie-downs, lift from the truck and move to the assembly area. Drive slow and keep the machine close to the ground.
5. Cut the strapping and remove the components from the shipping pallet.
6. Mount the reversible points or shovels to the tines and tighten fasteners to their specified torque.
7. Place the cultivator frame on stands and lay-out the components in their approximate position.
8. Refer to the tine position schematic.
Note: Schematic is a baseline starting point for reference.
9. Measure and mark the tine positions on the frame.
10. Mount the tines to the frame.
11. Attach the blade leveler and rear roller per parts drawing..
12. Tighten all fasteners to their specified torque.

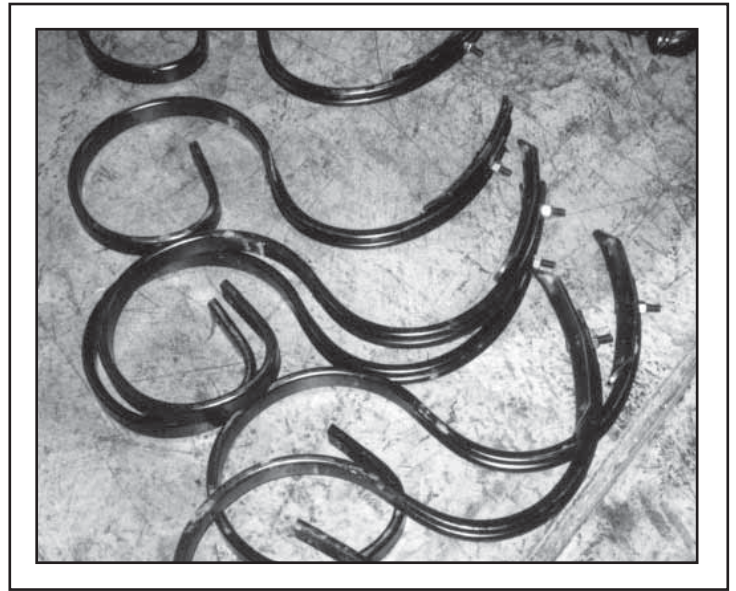

Fig. 7 - Tines With Reversible Points/Shovels



Fig. 8 - Layout

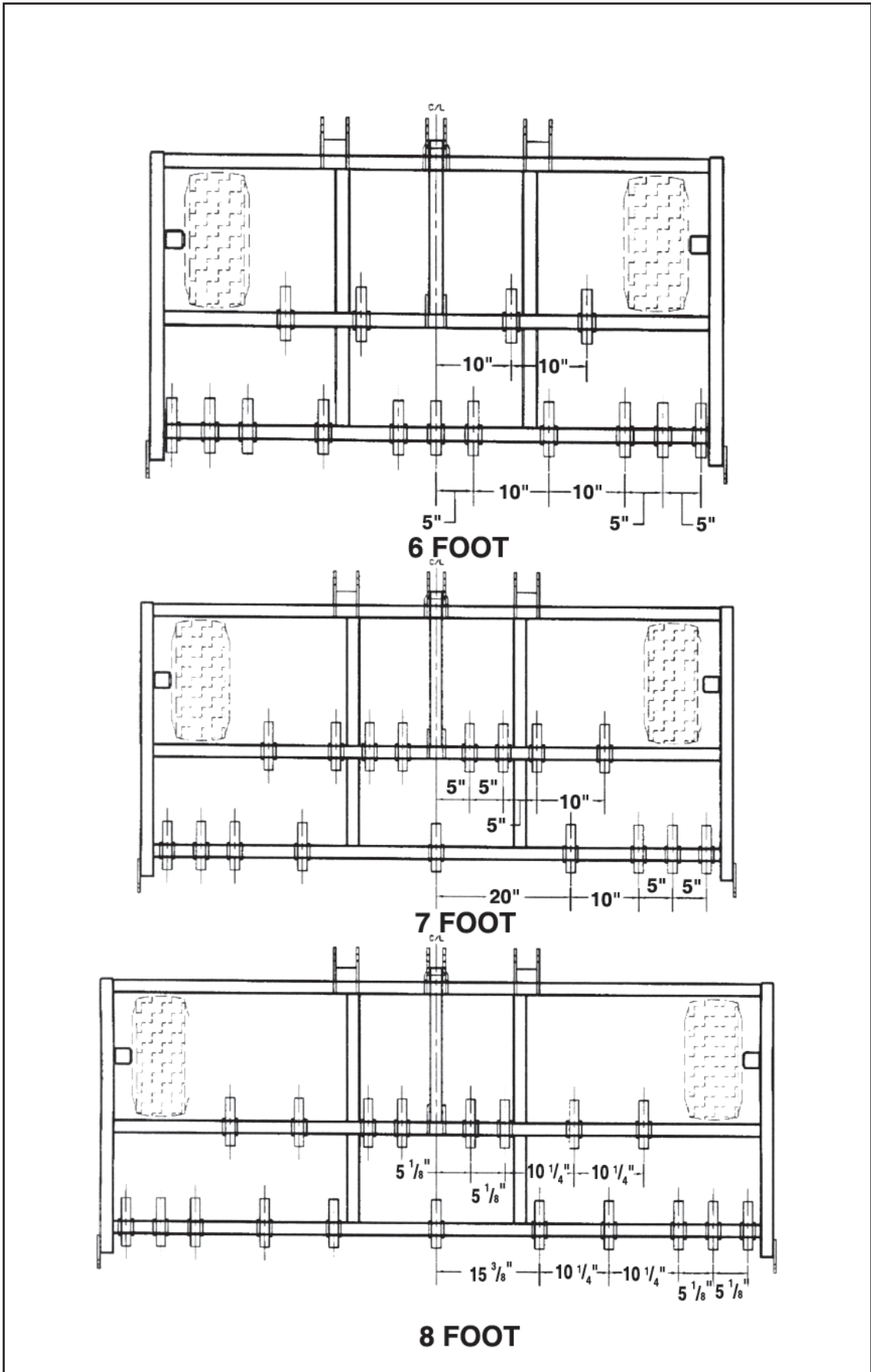

Fig. 9 - Tine Positions

8 SPECIFICATIONS

8.1 MECHANICAL

SPECIFICATIONS					
MODELS	AV3-4	AV3-5	AV3-6	AV3-7	AV3-8
Working Width:	4'	5'	6'	7'	8'
No. of Shanks:	11	13	15	17	19
Shank Size:	1 ¼" x ⅜" x 22"	1 ¼" x ⅜" x 22"	1 ¼" x ⅜" x 22"	1 ¼" x ⅜" x 22"	1 ¼" x ⅜" x 22"
Shank Clearance:	16"	16"	16"	16"	16"
Hitch:	Cat. 1	Cat. 1	Cat. 1	Cat. 1	Cat. 1 & 2
HP Rating:	18 to 32	18 to 32	22 to 39	26 to 47	30 to 53
Weight:	400 lbs.	480 lbs.	550 lbs.	660 lbs.	745 lbs.

SPECIFICATIONS ARE SUBJECT TO CHANGE WITHOUT NOTICE

8.2 BOLT TORQUE

CHECKING BOLT TORQUE

The tables shown below give correct torque values for various bolts and capscrews. Tighten all bolts to the torques specified in chart unless otherwise noted. Check tightness of bolts periodically, using bolt torque chart as a guide. Replace hardware with the same strength bolt.

ENGLISH TORQUE SPECIFICATIONS

Bolt Diameter "A"	Bolt Torque *					
	SAE 2		SAE 5		SAE 8	
	N.m	(lb-ft)	N.m	(lb-ft)	N.m	(lb-ft)
¼"	8	(6)	12	(9)	17	(12)
⅕"	13	(10)	25	(19)	36	(27)
⅜"	27	(20)	45	(33)	63	(45)
7/16"	41	(30)	72	(53)	100	(75)
½"	61	(45)	110	(80)	155	(115)
9/16"	95	(70)	155	(115)	220	(165)
5/8"	128	(95)	215	(160)	305	(220)
¾"	225	(165)	390	(290)	540	(400)
7/8"	230	(170)	570	(420)	880	(650)
1"	345	(225)	850	(630)	1320	(970)

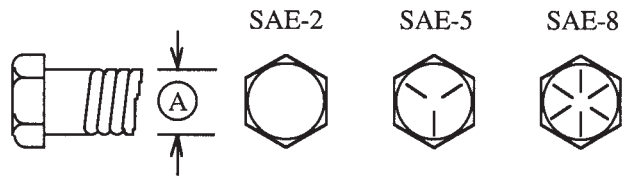

Torque figures indicated above are valid for non-greased or non-oiled threads and heads unless otherwise specified. Therefore, do not grease or oil bolts or capscrews unless otherwise specified in this manual. When using locking elements, increase torque values by 5%.

* Torque value for bolts and capscrews are identified by their head markings.

9 PARTS REFERENCE

9.1 ARENA-VATOR III ASSEMBLY

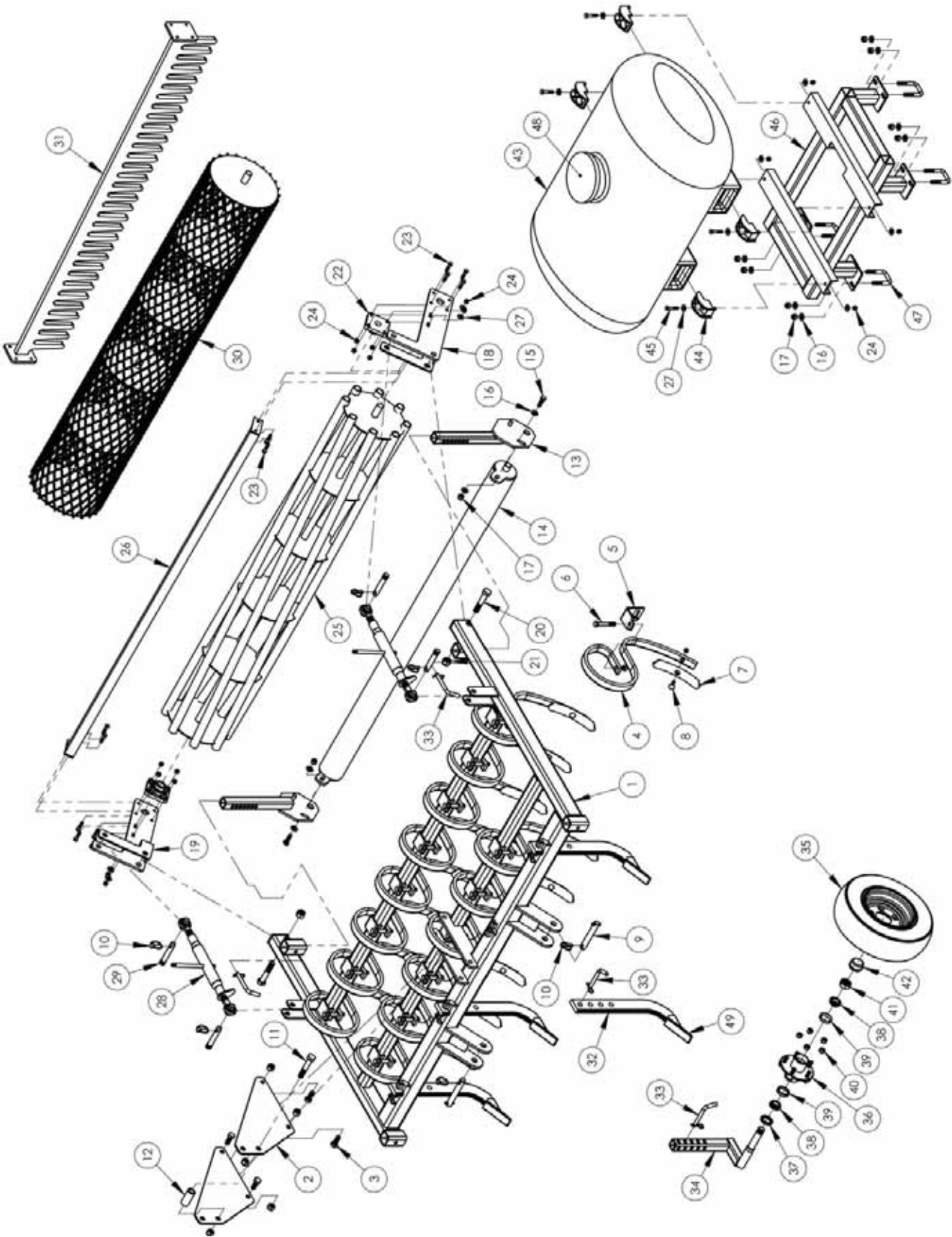

9.2 PARTS LIST

REF.	QTY.	PART NO.	DESCRIPTION
1	1	AV3-2004	4' Frame Weldment
1	1	AV3-2005	5' Frame Weldment
1	1	AV3-2006	6' Frame Weldment
1	1	AV3-2007	7' Frame Weldment
1	1	AV3-2008	8' Frame Weldment
2	2	CP-0160	Top Link Plate
3	4	AV-0320	5/8" x 1 1/2" NC Gr. 5 Cap Screw w/Nylock Nut
4	As Req'd	AV-0415	S-Tine - 32 x 10 x 560
5	As Req'd	AV-0420	S-Tine Clamp
6	As Req'd	AV-0312	1/2" x 3 1/2" NC Gr. 5 Cap Screw w/Nylock Nut
7	As Req'd	AV-0405	Reversible Point - 40 x 6 x 200
8	As Req'd	AV-0305	3/8" x 1 1/2" NC Elliptical Head Plow Bolt w/Hex Nut
9	2	AV-0450	P-7234 Cat. I Clevis Pin
	2	AV-0455	Cat. I & II Clevis Step Pin (AV3-8 Only) (Not Shown)
10	6	AV-0460	P-791 Lynch Pin
11	1	AV-0313	3/4" x 4 1/2" NC Gr. 5 Cap Screw w/Nylock Nut
12	1	AV-0164	Top Link Bushing
13	2	AV3-0200	Pipe Leveler Mounting Bracket
14	1	AV3-2104	4' Pipe Leveler
14	1	AV3-2105	5' Pipe Leveler
14	1	AV3-2106	6' Pipe Leveler
14	1	AV3-2107	7' Pipe Leveler
14	1	AV3-2108	8' Pipe Leveler
15	2	007-004-1	1/2" x 1 3/4" NC Gr. 5 Cap Screw
16	4	069-210-1	1/2" SAE Flat Washer
17	2	064-011-1	1/2" NC Nylock Nut
18	1	AV3-0162-LH	Roller Pivot Bracket - Left Hand
19	1	AV3-0162-RH	Roller Pivot Bracket - Right Hand
20	2	007-211-1	3/4" x 4 NC Gr. 5 Cap Screw
21	2	064-014-1	3/4" NC Nylock Nut
22	2	AV-0200	1" Roller Bearing 4 Bolt w/Lock Collar
23	12	006-007-1	3/8" x 1 1/2" NC Gr. 5 Cap Screw
24	12	064-009-1	3/8" NC Nylock Nut
25	1	AV3-0140	4' Pipe Roller
25	1	AV3-0150	5' Pipe Roller
25	1	AV3-0160	6' Pipe Roller
25	1	AV3-0170	7' Pipe Roller
25	1	AV3-0180	8' Pipe Roller
26	1	AV3-0194	4' Roller Scraper and Support Weldment
26	1	AV3-0195	5' Roller Scraper and Support Weldment
26	1	AV3-0196	6' Roller Scraper and Support Weldment

9.2 PARTS LIST

REF.	QTY.	PART NO.	DESCRIPTION
26	1	AV3-0197	7' Roller Scraper and Support Weldment
26	1	AV3-0198	8' Roller Scraper and Support Weldment
27	4	068-004-1	3/8" USS Flat Washer
28	2	HR-0200	Adjustable Top Link
29	4	HR-0105	Top Link Pin
30	1	AV3-2204	4' Mesh Roller
30	1	AV3-2205	5' Mesh Roller
30	1	AV3-2206	6' Mesh Roller
30	1	AV3-2207	7' Mesh Roller
30	1	AV3-2208	8' Mesh Roller
31	1	AV3-2140	4' Finger Rake
31	1	AV3-2150	5' Finger Rake
31	1	AV3-2160	6' Finger Rake
31	1	AV3-2170	7' Finger Rake
31	1	AV3-2180	8' Finger Rake
32	As Req'd	SC-C	Scarifier Shank (4 Hole) w/Point
33	As Req'd	P71111	1/2" Pin w/Keeper
49	As Req'd	162470	Point Only
AV3-GW Gauge Wheel Assembly			
34	1	AV3-0204	Gauge Wheel Spindle Arm Weldment (Right Hand)
	1	AV3-0205	Gauge Wheel Spindle Arm Weldment (Left Hand) (Not Shown)
35	2	480C-08545	Wheel and Tire
36	2	008-259-05	545 Hub w/Bearing Races (008-259-05)
37	2	3163	Hub Seal (SL-122-1)
38	4	3164	Bearing L44643
39	4	3165	Race L44610
40	10	3170	1/2" Lug Nut
41	2	3167	1" Slotted Nut (006-001-00)
	2	3168	Cotter Pin (19-2) (Not Shown)
42	2	3169	Grease Cap (021-003-00)
33	2	P71111	1/2" Pin w/Keeper
AV3-WT Water Tank Assembly			
43	1	5169249	60 Gallon Water Tank
44	4	5038698	Tank Hold Down
45	4	006-009-1	3/8" x 2" NC Gr. 5 Cap Screw
27	8	068-004-1	3/8" USS Flat Washer
46	1	AV3-2500	Tank Mount Weldment
47	4	3189	1/2" x 2" x 3 1/4" NC U-Bolt
16	8	069-210-1	1/2" SAE Flat Washer
17	8	064-011-1	1/2" NC Nylock Nut
48	1	5058188	Tank Lid
	2	5005021	Tank Fitting (Not Shown)

9.2 PARTS LIST

REF.	QTY.	PART NO.	DESCRIPTION
	2	5143188	Tank Ball Valve (Not Shown)
Pipe Leveler Kits AV3-4PL, 5PL, 6PL, 7PL & 8PL			
14	1	AV3-2104	4' Pipe Leveler (AV3-4PL)
14	1	AV3-2105	5' Pipe Leveler (AV3-5PL)
14	1	AV3-2106	6' Pipe Leveler (AV3-6PL)
14	1	AV3-2107	7' Pipe Leveler (AV3-7PL)
14	1	AV3-2108	8' Pipe Leveler (AV3-8PL)
13	2	AV3-0200	Pipe Leveler Mounting Bracket (All Kits)
33	2	P71111	½" Pin w/Keeper (All Kits)
15	2	007-004-1	½" x 1 ¾" NC Gr. 5 Cap Screw (All Kits)
16	4	069-210-1	½" SAE Flat Washer (All Kits)
17	2	064-011-1	½" NC Nylock Nut (All Kits)
Pipe Roller Kits AV3-4PR, 5PR, 6PR, 7PR & 8PR			
25	1	AV3-0140	4' Pipe Roller (AV3-4PR)
25	1	AV3-0150	5' Pipe Roller (AV3-5PR)
25	1	AV3-0160	6' Pipe Roller (AV3-6PR)
25	1	AV3-0170	7' Pipe Roller (AV3-7Pr)
25	1	AV3-0180	8' Pipe Roller (AV3-8PR)
26	1	AV3-0194	4' Roller Scraper and Support Weldment (AV3-4PR)
26	1	AV3-0195	5' Roller Scraper and Support Weldment (AV3-5PR)
26	1	AV3-0196	6' Roller Scraper and Support Weldment (AV3-6PR)
26	1	AV3-0197	7' Roller Scraper and Support Weldment (AV3-7PR)
26	1	AV3-0198	8' Roller Scraper and Support Weldment (AV3-8PR)
Mesh Roller Kits AV3-4MR, 5MR, 6MR, 7MR & 8MR			
30	1	AV3-2204	4' Mesh Roller (AV3-4MR)
30	1	AV3-2205	5' Mesh Roller (AV3-5MR)
30	1	AV3-2206	6' Mesh Roller (AV3-6MR)
30	1	AV3-2207	7' Mesh Roller (AV3-7MR)
30	1	AV3-2208	8' Mesh Roller (AV3-8MR)
26	1	AV3-0194	4' Roller Scraper and Support Weldment (AV3-4MR)
26	1	AV3-0195	5' Roller Scraper and Support Weldment (AV3-5MR)
26	1	AV3-0196	6' Roller Scraper and Support Weldment (AV3-6MR)
26	1	AV3-0197	7' Roller Scraper and Support Weldment (AV3-7MR)
26	1	AV3-0198	8' Roller Scraper and Support Weldment (AV3-8MR)
Roller Mounting Kit AV3-RMP (For Pipe Rollers & Mesh Rollers)			
18	1	AV3-0162-LH	Roller Pivot Bracket - Left Hand
19	1	AV3-0162-RH	Roller Pivot Bracket - Right Hand
22	2	AV-0200	1" Roller Bearing 4 Bolt w/Lock Collar
23	12	006-007-1	⅜" x 1 ½" NC Gr. 5 Cap Screw
24	12	064-009-1	⅜" NC Nylock Nut
27	4	068-004-1	⅜" USS Flat Washer

9.2 PARTS LIST

REF.	QTY.	PART NO.	DESCRIPTION
28	2	HR-0200	Adjustable Top Link
29	4	HR-0105	Top Link Pin
10	4	AV-0460	P-791 Lynch Pin
20	2	007-211-1	¾" x 4 NC Gr. 5 Cap Screw
21	2	064-014-1	¾" NC Nylock Nut
Finger Rake Kits AV3-4FR, 5FR, 6FR, 7FR & 8FR			
31	1	AV3-2140	4' Finger Rake (AV3-4FR)
31	1	AV3-2150	5' Finger Rake (AV3-5FR)
31	1	AV3-2160	6' Finger Rake (AV3-6FR)
31	1	AV3-2170	7' Finger Rake (AV3-7FR)
31	1	AV3-2180	8' Finger Rake (AV3-8FR)
Finger Rake Mounting Kit AV3-FMP (For Finger Rakes)			
18	1	AV3-0162-LH	Roller Pivot Bracket - Left Hand
19	1	AV3-0162-RH	Roller Pivot Bracket - Right Hand
23	8	006-007-1	⅜" x 1 ½" NC Gr. 5 Cap Screw
24	8	064-009-1	⅜" NC Nylock Nut
28	2	HR-0200	Adjustable Top Link
29	4	HR-0105	Top Link Pin
10	4	AV-0460	P-791 Lynch Pin
20	2	007-211-1	¾" x 4 NC Gr. 5 Cap Screw
21	2	064-014-1	¾" NC Nylock Nut
Scarifier Shank Kits AV3-SH2, SH4, & SH6			
32	As Req'd	M-10470B	Scarifier Shank (4 Hole) (2 per AV3-SH2, 4 per AV3-SH4, 6 per AV3-SH6)
33	As Req'd	P71111	½" Pin w/Keeper (2 per AV3-SH2, 4 per AV3-SH4, 6 per AV3-SH6)
AV3-WT Mounted Water Tank Kit			
43	1	5169249	60 Gallon Water Tank
44	4	5038698	Tank Clamp
45	4	006-009-1	⅜" x 2" NC Gr. 5 Cap Screw
27	8	068-004-1	⅜" USS Flat Washer
46	1	AV3 -2500	Tank Mount Weldment
47	4	3189	½" x 2" x 3 ¼" NC U-Bolt
16	8	069-210-1	½" SAE Flat Washer
17	8	064-011-1	½" NC Nylock Nut

QUANTITY CHART					
Part No./Desc.	AV3-4	AV3-5	AV3-6	AV3-7	AV3-8
AV-0415 S Tine	11	13	15	17	19
AV-0420 S Tine Clamp	11	13	15	17	19
AV-0312 Cap Screw	11	13	15	17	19
AV-0405 Rev. Point	11	13	15	17	19
AV-0305 Plow Bolt	11	13	15	17	19

9.3 AV3-PH PULL HITCH ASSEMBLY

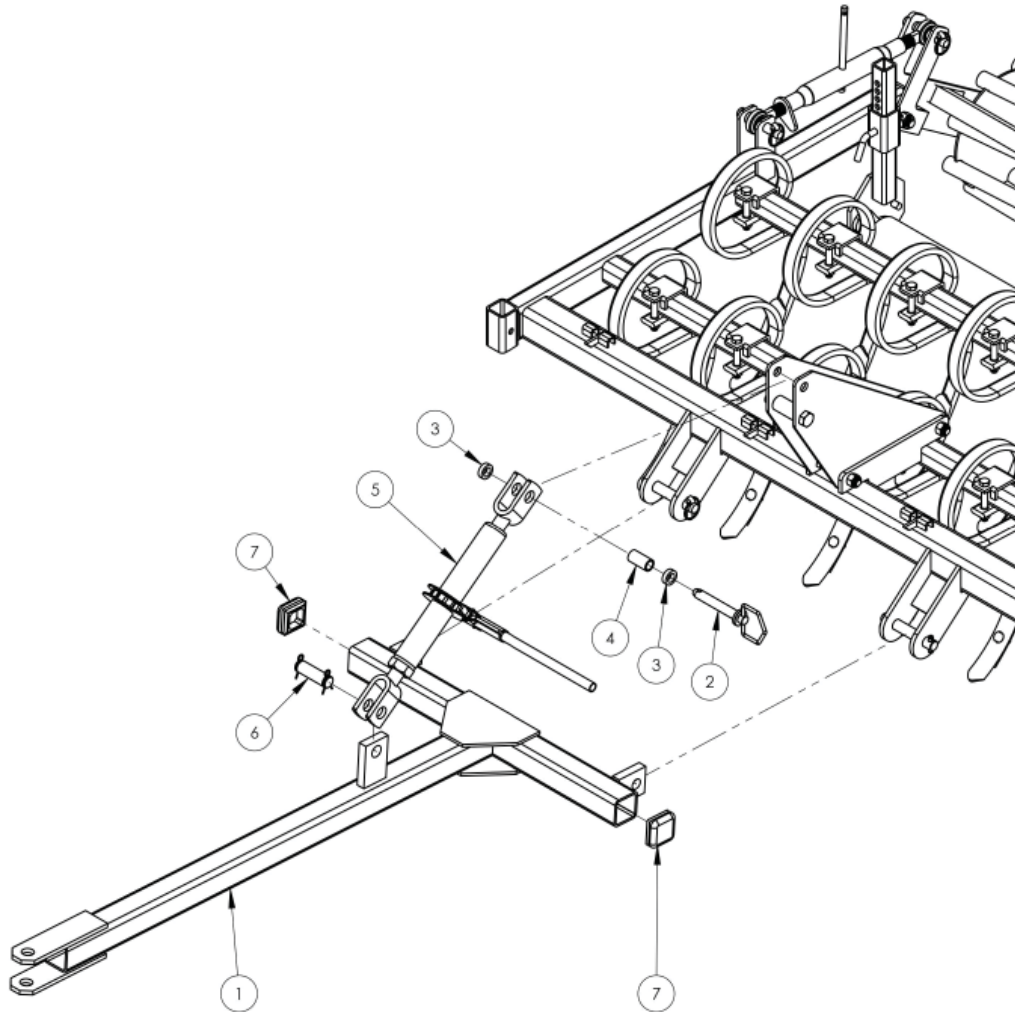

REF.	QTY.	PART NO.	DESCRIPTION
1	1	AV3-PH-0100	Pull Hitch Weldment
2	1	P7103CL	Hitch Pin ¾" x 5 ¾"
3	2	HR-0177	Short Spacer for Tine Bars
4	1	B831	bushing ¾" x 1 15/16"
5	1	SL-1541	Ratchet Jack
6	1	HR-0317	Clevis Pin 1"
7	2	HR-0634	Plastic Cap 2 ½" Square

9.4 OPTIONAL FEATURES

1. PULL HITCH:

Arena-Vator III Pull Type Hitch with Ratchet Jack for 4', 5', & 6' Models.

2. SHANK KIT:

- (a) Hook Arena-Vator III to a tractor before adjusting shanks.
- (b) Adjust shank height by removing hair cotter pin and shank lock pin.
- (c) Adjust shank up or down to the desired depth and then replace shank lock pins and hair cotter pin.

3. WATER TANK:

Can be added for additional weight to penetrate hard ground.

4. GAUGE WHEELS:

- (a) Controls the depth of the unit.
- (b) Creates consistent level travel to eliminate wash boarding.

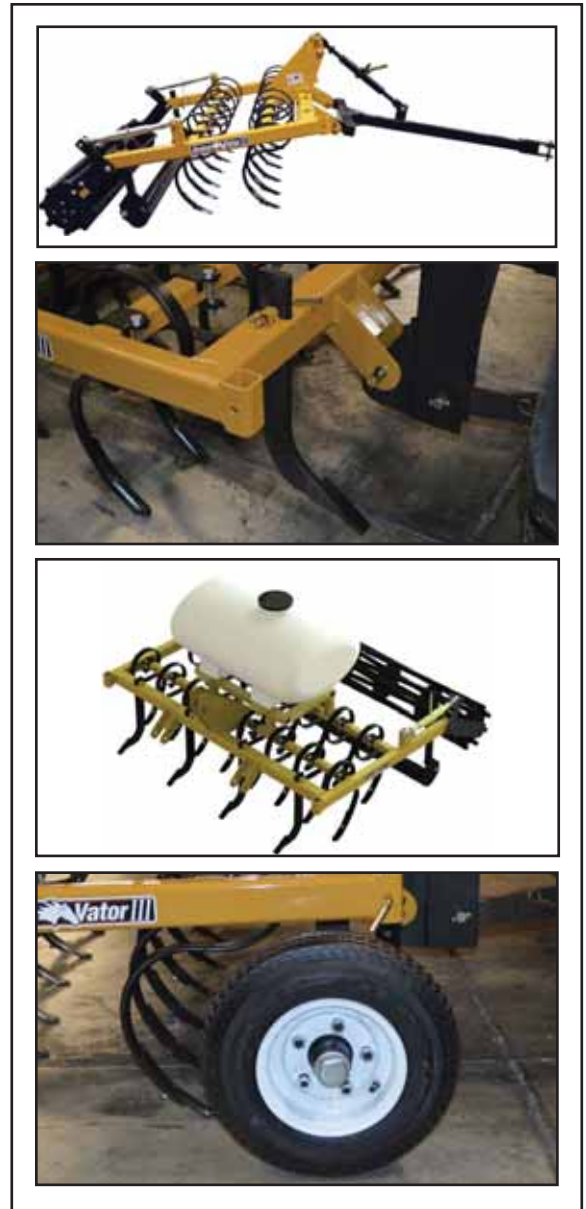

Build to suit your application ● Accessories							
Base Frame	Pipe Rollers	Mesh Roller	Finger Rakes	Pipe Levelers	Scarifier Shank Kit	Gauge Wheels (pr)	60 Gallon Water Tank
AV ³ -.4F	*AV ³ -.4PR	*AV ³ -.4MR	AV ³ -.4FR	AV ³ -.4PL	AV ³ -SH ²	AV ³ -GW	AV ³ -WT
AV ³ -.5F	*AV ³ -.5PR	*AV ³ -.5MR	AV ³ -.5FR	AV ³ -.5PL	AV ³ -SH ⁴	AV ³ -GW	AV ³ -WT
AV ³ -.6F	*AV ³ -.6PR	*AV ³ -.6MR	AV ³ -.6FR	AV ³ -.6PL	AV ³ -SH ⁴	AV ³ -GW	AV ³ -WT
AV ³ -.7F	*AV ³ -.7PR	*AV ³ -.7MR	AV ³ -.7FR	AV ³ -.7PL	AV ³ -SH ⁴	AV ³ -GW	AV ³ -WT
AV ³ -.8F	*AV ³ -.8PR	*AV ³ -.8MR	AV ³ -.8FR	AV ³ -.8PL	AV ³ -SH ⁶	AV ³ -GW	AV ³ -WT

*Requires AV3RMP Roller Mounting Package to complete - includes bearings, brackets, adjuster links and hardware.

10 LIMITED WARRANTY



GEARMORE, INC., warrants each new Gearmore product to be free from defects in material and workmanship for a period of twelve (12) months from date of purchase to the original purchaser. This warranty shall not apply to implements or parts that have been subject to misuse, negligence, accident, or that have been altered in any way.

Our obligation shall be limited to repairing or replacement of any part, provided that such part is returned within thirty (30) days from date of failure to Gearmore through the dealer from whom the purchase was made, transportation charges prepaid.

This warranty shall not be interpreted to render us liable for injury or damages of any kind or nature, direct, consequential or contingent, to person or property. This warranty does not extend to loss of crops, loss because of delay in harvesting or any other expenses, for any other reasons.

Gearmore in no way warrants engines, tires, or other trade accessories, since these items are warranted separately by these respective manufacturers.

Gearmore reserves the right to make improvements in design or changes in specification at any time, without incurring any obligations to owners or units previously sold.

GEARMORE, INC.
13477 Benson Ave.
Chino, CA 91710

Always refer to and heed machine operating warning decals on machine.

The serial number of this product is stored in our computer database, thus submitting a warranty registration card is not required.