

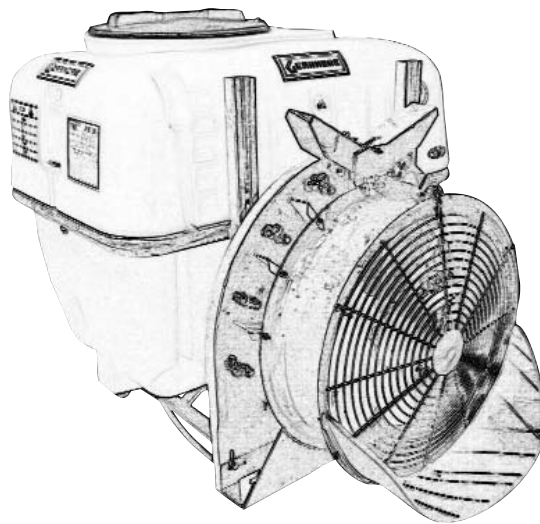

AIR BLAST SPRAYERS



**OPERATION, SERVICE
& PARTS MANUAL FOR
MODELS: APL-G200, & APL-G400**

April 2013

TABLE OF CONTENTS

<u>SECTION</u>	<u>DESCRIPTION</u>	<u>PAGES</u>
1	Introduction	3
2	Operating Sprayer.....	4
3	Lubrication	5
4	Cleaning & Storage.....	6
5	Suction Filter Service	7
6	Pump Maintenance.....	8
7	General Safety Information	9
8	Troubleshooting	10
9	Formula & Rate Chart	11
10	Parts	12 - 42
10.1	Tank Assembly 50 Gallon	12-14
10.2	Tank Assembly 100 & 150 Gallon	15-17
10.3	Run of Fluids 50 Gallon	18-20
10.4	Run of Fluids 100 & 150 Gallon	21-23
10.5	Fan Assembly	24-26
10.6	Gearbox Assembly	27-28
10.7	Pump Assembly for APL200.....	29-31
10.8	Pump Assembly	32-34
10.9	Valve Assembly.....	35-36
10.10	Nozzle Assembly.....	37
10.11	Driveline Assembly	38
10.12	Optional Tommy Gun	39-40
10.13	Optional Electric Controls.....	41-42
11	Warranty	43

1 INTRODUCTION

We welcome you as an owner of the Gearmore 3-point hitch sprayer. Before you read on to the operation and maintenance of the sprayer, please read the following general information.

1. **POWER SOURCE:**

The sprayer is designed to mount to any 540 RPM tractor with a 3-point hitch. The horsepower required will vary depending on the pressure setting of the control valve.

2. **PUMP:**

The pump on the sprayer is a diaphragm pump. Pistons power the diaphragms that pump the liquid. The unit has protection against corrosion, as the valves are stainless steel.

3. **TANK:**

The tank comes with a jet agitation system. It also has a sump, so the tank can be completely drained.

4. **STRAINERS:**

The sprayer is equipped with three strainers. A large filter screen is located under the tank cover. A main strainer located by the side of the pump and a strainer screen in every nozzle assembly. All strainers are easily accessible for cleaning.

5. **TRANSMISSION:**

Special single speed transmission with neutral. Speed one and neutral are indicated by the decal on the machine. Neutral is for when you want to use your sprayer for handgun spraying and thus, the fan will not be turning.

6. **BLOWER:**

Air is supplied by an 8 blade propeller. The fan is made of a special high strength plastic alloy and precision balanced for smoother operation. The whole fan assembly is protected by heavy wire mesh screening. However, special care should be taken when working around the blower.

7. **NOZZLES:**

The air blast fan assembly is equipped with special ceramic nozzle tips that can be changed for different gallonage requirements. The nozzles can be shut off individually by turning 90 degrees.

2 TO OPERATE SPRAYER

1. Connect sprayer to tractor 3-point hitch.
2. Connect up the P.T.O. driveshaft, after you have checked to make sure the driveshaft is not too long.
3. Check strainer screen, to make sure it is clean.
4. Check strainer shut-off valve, making sure the handle is in the open position.
5. Select transmission speed, if your sprayer is equipped with the air blast fan assembly.
6. Refer to calibration page to calibrate the sprayer. Set regulator pressure as required.
Important - The pressure regulator adjusting knob must be unscrewed (turned to left) as far out as possible before operating sprayer. Then gradually screw in (turn to right) to desired pressure. Failure to operate in this manner could cause a sudden surge, which could damage the sprayer. By sliding the control handle left towards the pressure gauge, you can turn the valve one-half a turn to put the valve in bypass position. This would be used for mixing chemicals, etc. It takes the pressure off the pump and sends the liquid back to the tank. Turn the valve in the opposite direction for spraying. By sliding the handle away from the pressure gauge, you can adjust the pressure setting by turning the valve.
7. Engage tractor P.T.O. and run for a couple of minutes to make sure the jet agitator has mixed the chemicals thoroughly. Last, turn the control valve handles to the position required. Either right hand, left hand or both sides spraying.

Remember, it is always best to make a practice run with water to be sure you have the correct rates and coverage.

3 LUBRICATION

1. **DRIVESHAFT** - The driveshaft comes not greased, so must be done before sprayer is put into use. After that, grease *every 50 hours*. It is also necessary, from time to time, to untelescope the driveshaft to clean and re-grease tubings.
2. **TRANSMISSION** - Observe the sight gauge, and install 90 weight transmission oil when necessary.
3. **PUMP** - The clear oil reservoir should be filled to the indicator mark. If oil is low, add engine oil, non-foaming, non-detergent 30 weight oil. The pump oil must be changed after the first 100 running hours and then at the end of every working season. *(See pump page for more details.)*

GENERAL MAINTENANCE

Carefully follow all instructions as stated in this operators manual. This includes lubrication, maintenance and operation of the sprayer. The sprayer was designed and built for years of reliable service if properly cared for. However, an air blast sprayer is a high R.P.M. machine, thus, daily attention is required.

1. Check all bolts for tightness.
2. Check sprayer for leaks.

4 CLEANING & STORAGE

1. Wash and flush out sprayer after completion of each phase of your spraying program.
2. Flush out sprayer when changing chemicals, if there is a possibility of incompatibility.
3. Clean sprayer very thoroughly before storing at the end of the spraying season. If you are in a cold climate, final rinse should be with a sufficiently concentrated anti-freeze to prevent freeze-up in areas that were not thoroughly drained.
4. Check sprayer over for needed repairs before time to spray again.
5. Preparing the sprayer for use in the Spring means completion of all needed repairs, installation of all drain plugs and checking sprayer for leaks with a tank of water.

SAFETY TIPS

- Sprayer should be operated only by qualified persons.
- Always* fill sprayer slowly to avoid spillage.
- When starting sprayer, maintain a safe distance from moving parts.
- Never* run P.T.O. at speeds in excess of 540 R.P.M.
- Do not* make adjustments when sprayer is running, unless specifically recommended.
- Never* leave sprayer unattended while it is running.
- Keep hands, feet and clothing away from all moving parts.
- Handle chemicals carefully; follow the manufacturer's directions for mixing and applying chemicals.

5 SUCTION FILTER SERVICING

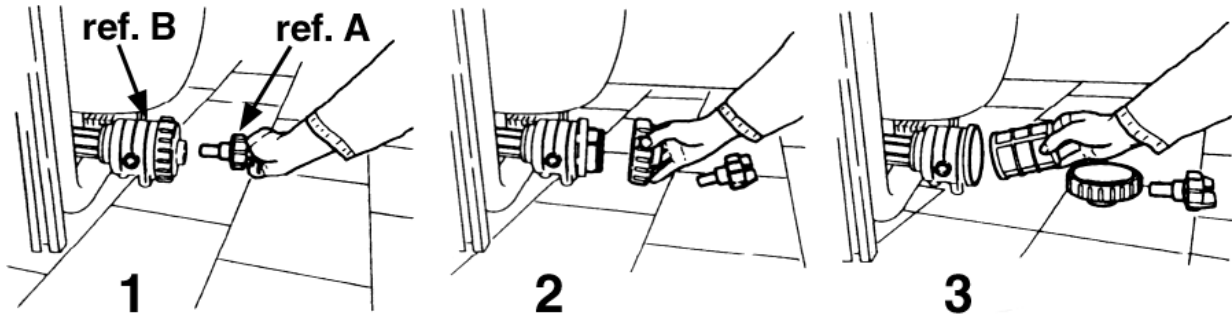

1. Remove the plunger valve (ref. A) from filter assembly (ref. B).
2. Unscrew large ring nut on filter assembly, removing nut and cover.
3. Remove and clean strainer on cartridge, replace if necessary.

6 PUMP MAINTENANCE

The pump is serviced, tested and ready for use. Nevertheless, before starting the sprayer, we advise checking the oil level.

The oil level should be filled to the mark on the plastic tube.

When adding oil, remove cap and fill to level mark with SAE 30 weight engine oil.

CHANGING THE OIL

1. Remove the pump and drain the oil by turning the pump upside down. To do this remove the filler cap and turn the P.T.O. shaft by hand.
2. Fill the crankcase with mineral (flushing) oil to wash all internal parts. Then drain pump again.
3. Add new oil and at the same time turn the P.T.O. shaft by hand. When the correct oil level has been reached, continue to turn the shaft until all the air bubbles in the oil have disappeared.

DIAPHRAGM AND VALVE REPLACEMENT

I. *Valve & O-ring Replacement*

1. Occasionally debris can cause the valves to not seat properly or damage the o-rings. To check for this problem, follow these steps:
 - a. Remove the check valve manifold. (See parts list for your model.)
 - b. With manifold removed, valves can readily be removed and checked for debris or wear.

To replace valves or o-rings, refer to parts list for appropriate kits.

II. *Diaphragm Replacement*

1. Drain the oil from the pump. Rotate the shaft to remove excess oil.
2. Remove the pump heads.
3. Use a box wrench to remove the diaphragm retaining bolt, support washer and diaphragm.
(To replace diaphragms order appropriate repair kit. See parts list.)
4. Turn the crankshaft to bring the piston to its downstroke and seat the new diaphragm into the sleeve groove. Install retaining washer and tighten bolt.
5. Refill crankcase with 30 weight oil. Rotate the shaft to distribute oil and fill to proper level.

7 GENERAL SAFETY INFORMATION



WARNING - Do not pump flammable or explosive fluids such as gasoline, fuel oil, kerosene, etc. Do not use in explosive atmospheres. The pump should be used only with liquids compatible with the pump component materials. Failure to follow this warning may result in personal injury and / or property damage and will void the product warranty.

Use of pressure relief device, on the discharge side of pump, is required to prevent damage from pressure build-up, if the discharge is closed or blocked, while the power source is still running.

Do not operate pump above recommended R.P.M.

Do not pump at pressure higher than the maximum recommended for the pump (*see specifications*).

Operate pump between 45° and 145° F liquid temperatures.

Make certain that the power source conforms to the requirements of your equipment.

Provide adequate protection in guarding around the moving parts, such as the shaft and pulleys.

Disconnect power before servicing.

Release all pressure within the system before servicing any component.

Drain all liquids from the system before servicing.

Secure the discharge lines before starting the pump. An unsecured discharge line may whip, causing personal injury and/or property damage.

Check hoses for weak or worn condition before each use. Make certain that all connections are tight and secure.

Periodically inspect the pump and the system components. Perform routine maintenance as required (*see maintenance section*).

Do not operate a gasoline engine in an enclosed area. Be sure the area is well ventilated.

Use only pipe, hose and fittings rated for maximum rated pressure of pump or pressure at which pressure relief valve is set. Check with local supplier for proper pressure rating. (*Do not use used pipe!*)

Do not use these pumps for pumping water or other liquids for human or animal consumption.

8 TROUBLESHOOTING

PROBLEM:	CAUSE:	REMEDY:
The pump does not draw water.	One or more valves are seating improperly. Suction line is plugged or collapsed. Clogged strainer.	Examine the valve seatings and clean them. Examine suction line. Clean strainer.
Pressure gauge fluctuates excessively.	The pump is sucking in air through the suction union or air has not been entirely evacuated from the pump.	Examine the suction hose and make sure it is firmly secured. Run the pump with the outlet hose open to evacuate air from the pump.
The liquid flow is irregular.	One or more valves are seating improperly.	Examine the valve seatings and clean them.
Output drops and the pump is noisy.	Oil level is too low.	Add oil to correct level (halfway up the sight tube).
Oil comes out of the discharge port.	One or more diaphragms split.	Drain the pump of oil. Dismantle the heads and fit new diaphragms. Fill to correct oil level with motor oil (30W).
Water is pumped at little or no pressure.	The sealing valve on the pressure control valve is worn.	Replace washer and, if necessary, the valve seat.

9

FORMULA & RATE CHART

For Calibrating Gearmore Air Blast Sprayers

These must be known:

1. Tree spacing in feet (swath width)
 2. Tractor speed in feet per minute
 3. Gallons per acre desired
- Note:** (a.) 1 acre = 43,560 sq. ft.
 (b.) 1 MPH = 88 ft./min.

Tree spacing _____ ft. x tractor speed _____ ft./min. x application rate _____ gal./acre , 43,560 = G.P.M. Divide G.P.M. by number of sprayer nozzles to determine G.P.M. per nozzle. Now choose correct nozzle disc and pressure setting from charts. Charts give G.P.M. per nozzle disc.

CALIBRATION FORM

Tree spacing _____ ft.
 Tractor speed _____ ft./min.
 Application rate _____ gal./acre

Tree spacing _____ ft. x tractor speed _____ ft./min. x application rate _____ gal./acre , 43,560 = G.P.M.

Next: G.P.M. _____ , number of nozzles _____ = _____ G.P.M. per nozzle
 Refer to chart for: Nozzle disc # _____ Swirl plate _____
 Pressure setting _____ P.S.I.

RATE CHART FOR SINGLE NOZZLES, WITH SMALL PINK DISC

DISC SWIRL SIZE PLATE		PRESSURE (P.S.I.)										
		50	75	100	125	150	175	200	250	300	350	400
0.8	2 hole	.16	.18	.20	.22	.24	.26	.28	.30	.34	.36	.38
1.0	1.0	.25	.30	.36	.40	.44	.48	.51	.58	.64	.69	.72
1.2	1.0	.40	.49	.57	.63	.69	.74	.78	.87	.97	1.04	1.11
1.5	1.2	.55	.64	.74	.81	.90	.96	1.02	1.12	1.22	1.31	1.37
1.8	1.5	.76	.94	1.09	1.21	1.32	1.39	1.47	1.61	1.74	1.87	1.99
2.0	1.8	.92	1.15	1.37	1.50	1.65	1.73	1.95	2.11	2.37	2.54	2.63
2.2	2.0	1.02	1.27	1.53	1.67	1.82	1.96	2.11	2.35	2.57	2.77	2.94
2.5	2.2	1.57	1.81	2.05	2.26	2.45	2.63	2.81	3.03	3.29	3.53	3.72

10

PARTS

10.1 For Tank Assembly 50 Gallon

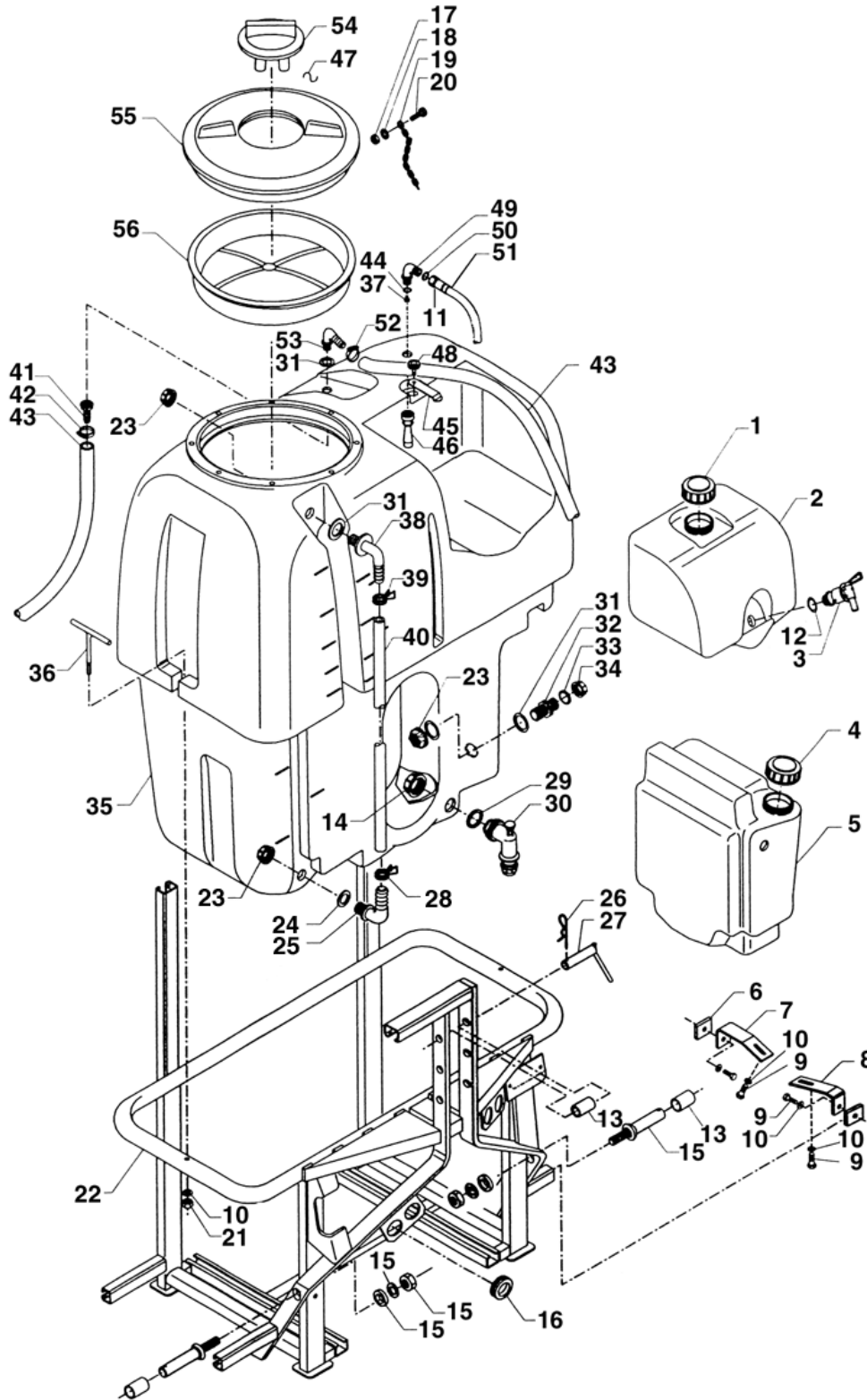

10

PARTS

10.1 For Tank Assembly 50 Gallon

<u>REF #</u>	<u>QTY.</u>	<u>PART NO.</u>	<u>DESCRIPTION</u>
1	1	0600187	Lid
2	1	0600189	Tank, Handwash
3	1	0600190	Drain Valve
4	1	0600187	Lid
5	1	0600182	Tank, Flush
6	2	0100107	Plate
7	1	0101477	Bracket
8	1	0101478	Bracket
9	4	1800036	Bolt M10 x 25
10	6	1800130	Washer D.10
11	2	1300036	Fitting Assembly
12	1	0600191	Gasket
13	4	2100135	Bushing 28.4 x 22.4
14	1	1400009	Nut, Ring
15	2	2100009	Lift Pin Assembly
16	4	2900001	Protector D.22
17	1	1800177	Nut M5
18	1	1800113	Washer 6.4 x 12.5
19	1	1400007	Chain
20	1	1800003	Bolt M5 x 12
21	2	1800186	Nut M.10
22	1	0101454	Frame
23	3	1400001	Nut
24	1	0600014	Gasket
25	1	1400130	Elbow
26	1	2100001	Hair Pin
27	1	0100203	Pin D.18
28	1	1800350	Clamp D2.9 x 9
29	1	1700015	Gasket
30	1	1400212	Drain Valve
31	3	1700001	Gasket 33 x 21 x 2
32	1	1400002	Nipple
33	1	1700021	Gasket 19 x 4
34	1	1400124	Plug
35	1	0600184	Tank 50 Gallon
36	2	0101476	T Handle
37	1	1400204	Nozzle D.1.5
38	1	1400130	Elbow
39	1	0600051	Clamp

Continued....

10 PARTS

10.1 For Tank Assembly 50 Gallon

<u>REF #</u>	<u>QTY.</u>	<u>PART NO.</u>	<u>DESCRIPTION</u>
40	As Req'd	12X17	Hose 12 x 17 Per Foot
41	1	1400192	Fitting
42	1	1500007	Clamp
43	As Req'd	19X26	Hose 19 x 26 Per Foot
44	1	1700006	O-Ring 36 x 26 x 5
45	1	0600192	Strap
46	1	1400074	Agitator
47	1	2100143	Hook
48	1	0600193	Knob
49	1	1400075	Elbow
50	1	1700010	Gasket 18 x 12 x 2
51	As Req'd	10X19	Hose 10 x 19 Per Foot
52	1	1500003	Clamp
53	1	1400062	Elbow D.20
54	1	0600007	Lid, Vent
55	1	00.723.010	Lid
56	1	00.646.000	Strainer Basket

10

PARTS

10.2 For Tank Assembly 100 & 150 Gallon

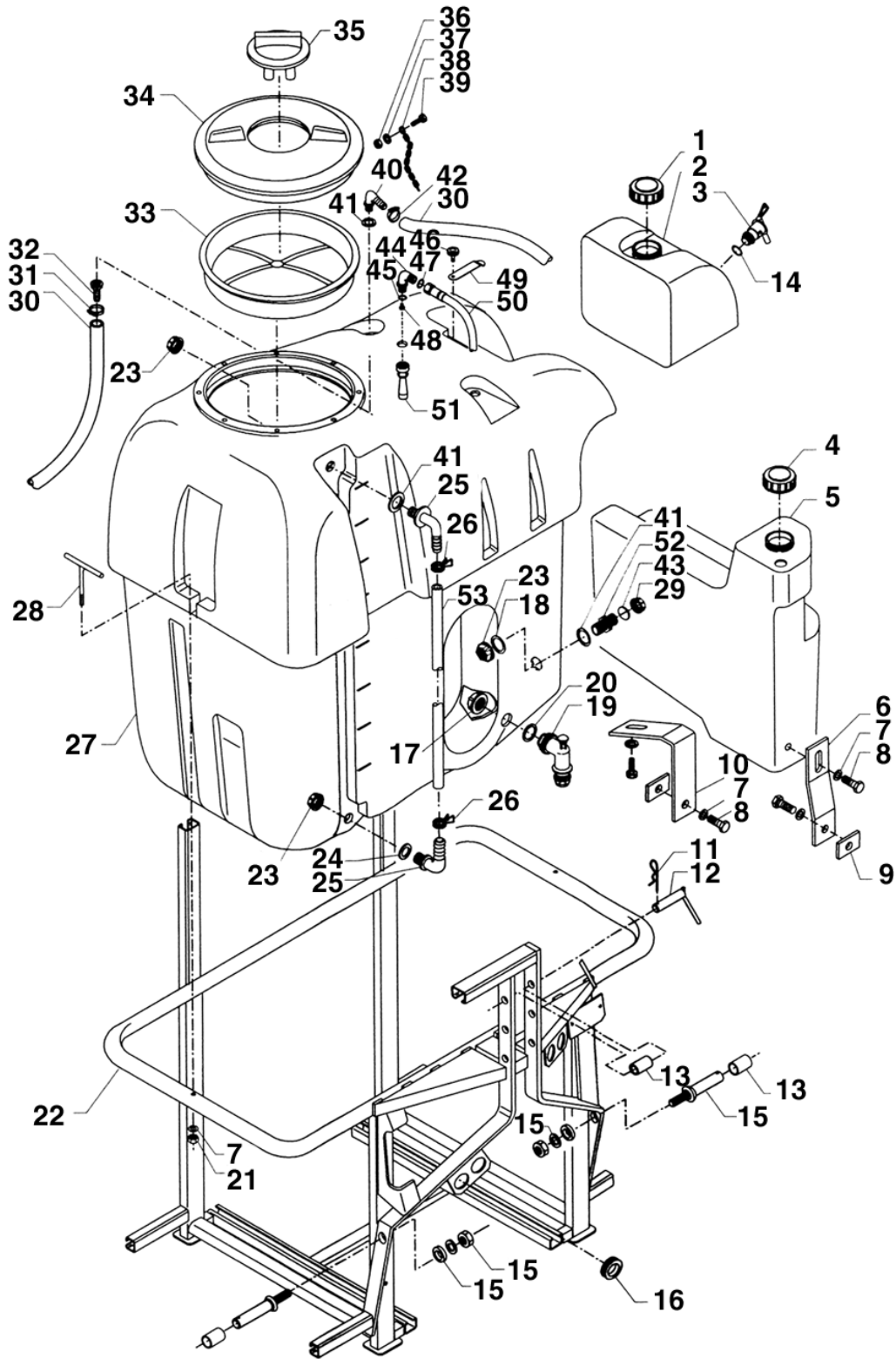

10 PARTS

10.2 For Tank Assembly 100 & 150 Gallon

<u>REF #</u>	<u>QTY.</u>	<u>PART NO.</u>	<u>DESCRIPTION</u>
1	1	0600187	Lid
2	1	0600189	Tank, Handwash
3	1	0600190	Valve, Drain
4	1	0600187	Lid
5	1	0600167	Tank, Flush
6	1	0101488	Support
7	6	1800130	Washer M.10
8	4	1800036	Bolt M10 x 25
9	2	0100107	Plate, Threaded
10	1	0101487	Support
11	1	2100001	Hair Pin
12	1	0100203	Pin D.18
13	4	2100135	Bushing 28.4 x 22.4 L=45
14	1	0600191	Gasket
15	2	2100007	Lift Pin Assembly
16	4	2900001	Garment, Rubber D.22
17	1	1400009	Ring Nut
18	1	0600014	Gasket
19	1	1400212	Drain Plug Assembly
20	1	1700015	Gasket 57.5 x 40 x 3
21	2	1800186	Nut M10
22	1	0101450	Frame
23	3	1400001	Ring Nut
24	1	2600009	Gasket
25	2	1400130	Elbow
26	2	0600051	Clamp
27	1	0600185	Tank 100 Gallon
27	1	0600186	Tank 150 Gallon
28	2	0101476	T Handle
29	1	1400124	Plug
30	As Req'd	19X26	Hose 19 x 26 Per Foot
31	1	1500007	Clamp
32	1	1400192	Nipple D.20
33	1	0600023	Strainer Basket
34	1	0600006	Lid 17 7/8" O.D.
35	1	0600007	Vent Lid
36	1	1800177	Nut M5
37	1	1800113	Washer 6.4 x 12.5

Continued...

10 PARTS

10.2 For Tank Assembly 100 & 150 Gallon

<u>REF #</u>	<u>QTY.</u>	<u>PART NO.</u>	<u>DESCRIPTION</u>
38	1	1400007	Chain D3.5 L=300
39	1	1800003	Bolt M5 x 12
40	1	1400062	Elbow D.20
41	3	1700001	Gasket
42	1	1500003	Clamp
43	1	1700021	Gasket
44	1	1400075	Elbow
45	1	1700006	Gasket
46	1	0600193	Knob
47	1	1700010	Gasket
48	1	1400204	Nozzle D1.5
49	1	0600192	Strap
50	1	1600690	Hose 10 x 19
51	1	1400074	Agitator Body
52	1	1400002	Nipple
53	As Req'd	12X17	Hose 12 x 17 Per Foot

10 PARTS

10.3 For Run of Fluids - 50 Gallon

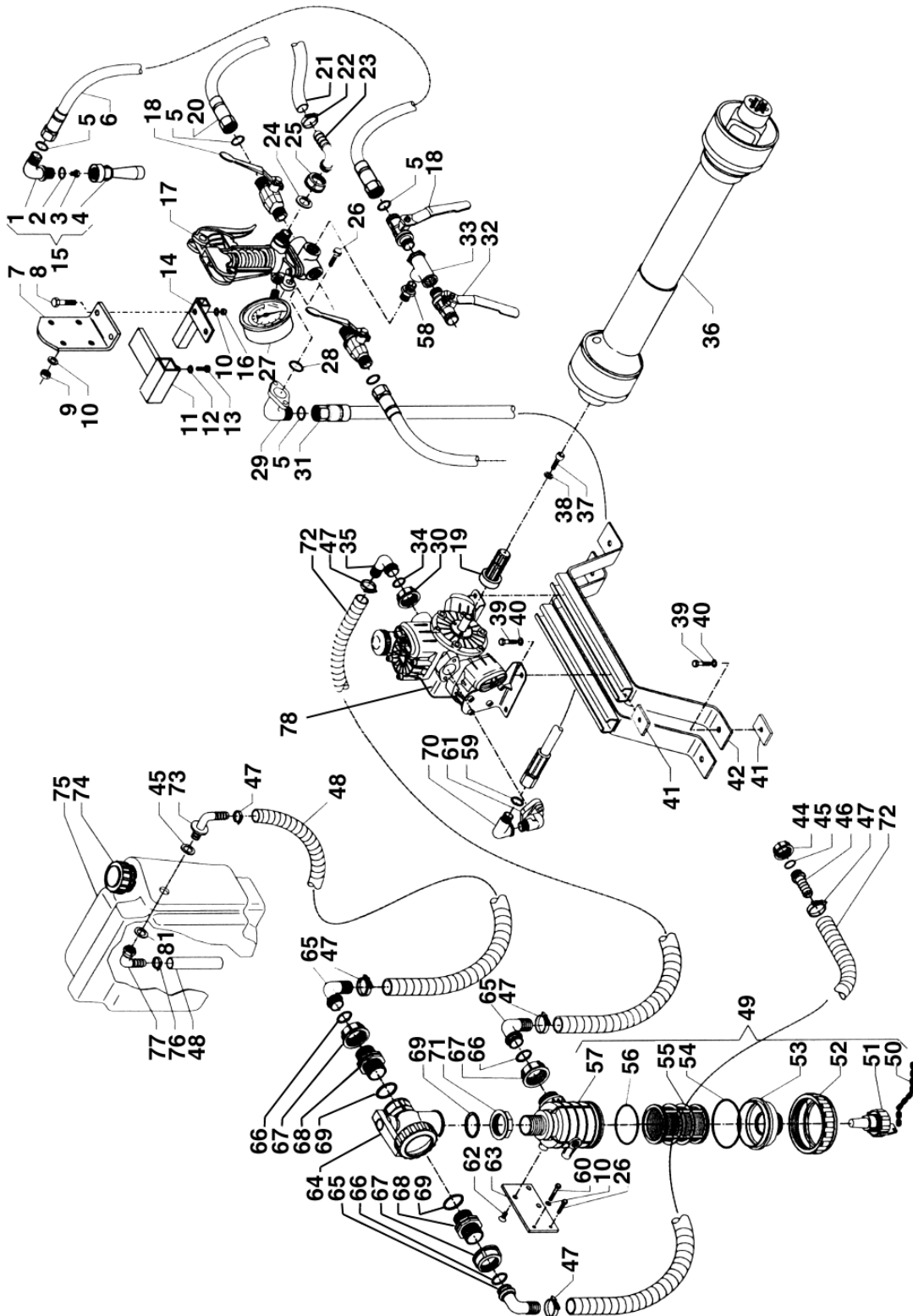

10

PARTS

10.3 For Run of Fluids - 50 Gallon

<u>REF #</u>	<u>QTY.</u>	<u>PART NO.</u>	<u>DESCRIPTION</u>
1	1	1400075	Elbow
2	1	1700006	O-Ring 36 x 26 x 5
3	1	1400204	Nozzle D.1.5
4	1	1400074	Body
5	5	1700010	Gasket
6	1	1600690	Hose 10 x 19 L=1250
7	1	320406	Support Bracket
8	2	1800021	Bolt M8 x 20
9	2	1800180	Nut M8
10	5	1800120	Washer D.8
11	1	0100236	Bracket
12	1	1800131	Washer M10 x 30 x 2.5
13	1	1800063	Bolt M10 x 20
14	1	0100235	Support
15	1	1400200	Agitator Assembly
16	2	1800181	Nut M8
17	1	GS40I	Control Valve Assembly
18	2	130491	Ball Valve R.H.
19	1	621370	Adaptor 20 mm
20	2	1600277	Hose 10 x 19
21	As Req'd	19X26	Hose 19 x 26 Per Foot
22	2	1500003	Clamp
23	1	550460	Elbow D.18
24	1	OR1554262	O-Ring 15.54 x 2.62
25	1	550450	Ring Nut
26	3	1800024	Bolt M8 x3 5
27	1	550545	Gauge
28	2	390180	O-Ring 18.72 x 2.62
29	1	450145	Flange
30	1	580060	Ring Nut
31	1	1600003	Hose 10 x 19
32	1	130492	Ball Valve L.H.
33	1	1300035	Tee
34	1	390290	O-Ring 29 x 3
35	1	580040	Elbow D.30
36	1	7104056FFT077	Driveline
37	1	680350	Bolt M8 x 35
38	1	961340	Washer D.8.5
39	8	1800036	Bolt M10 x 25

Continued....

10

PARTS

10.3 For Run of Fluids - 50 Gallon

<u>REF #</u>	<u>QTY.</u>	<u>PART NO.</u>	<u>DESCRIPTION</u>
40	8	1800130	Washer M10
41	4	0100107	Plate
42	2	0101456	Support Mount
44	1	1400026	Ring Nut
45	2	1700011	Gasket 40 x 26 x 2
46	1	1400193	Hose Barb D.25
47	6	1500004	Clamp
48	As Req'd	25X37	Hose 25 x 37 Per Foot
49	1	1400197	Filter Assembly
50	1	1400007	Chain, Plastic L=300
51	1	1400205	Plug
52	1	1400206	Ring Nut
53	1	1400207	Cover
54	1	1400209	O-Ring 5.34 x 91.44 x 102.1
55	1	1400208	Strainer
56	2	1700052	O-Ring 71.1 x 2.6
57	1	1400210	Body
58	1	1300034	Nipple
59	1	0600188	Gasket
60	1	1800027	Bolt M8 x 40
61	1	1040760	Flange
62	3	1800447	Bolt M8 x 16
63	1	0101475	Bracket
64	1	1400362	Ball Valve
65	3	1400057	Elbow D.25
66	3	1700012	O-Ring 31.89 x 26.65 x 2.62
67	3	1400013	Ring Nut
68	2	1400149	Nipple 1 1/4"
69	3	1700009	O-Ring 48.15 x 37.47 x 5.34
70	1	1300001	Elbow, Brass
71	1	1400009	Ring Nut
72	As Req'd	30X42	Hose 30 x 42 Per Foot
73	1	1400042	Elbow D.25
74	1	0600187	Lid
75	1	0600182	Tank
76	1	1500008	Clamp
77	1	1400141	Elbow D.25
78	1	AR403	Pump Assembly

10

PARTS

10.4 For Run of Fluids - 100 & 150 Gallon

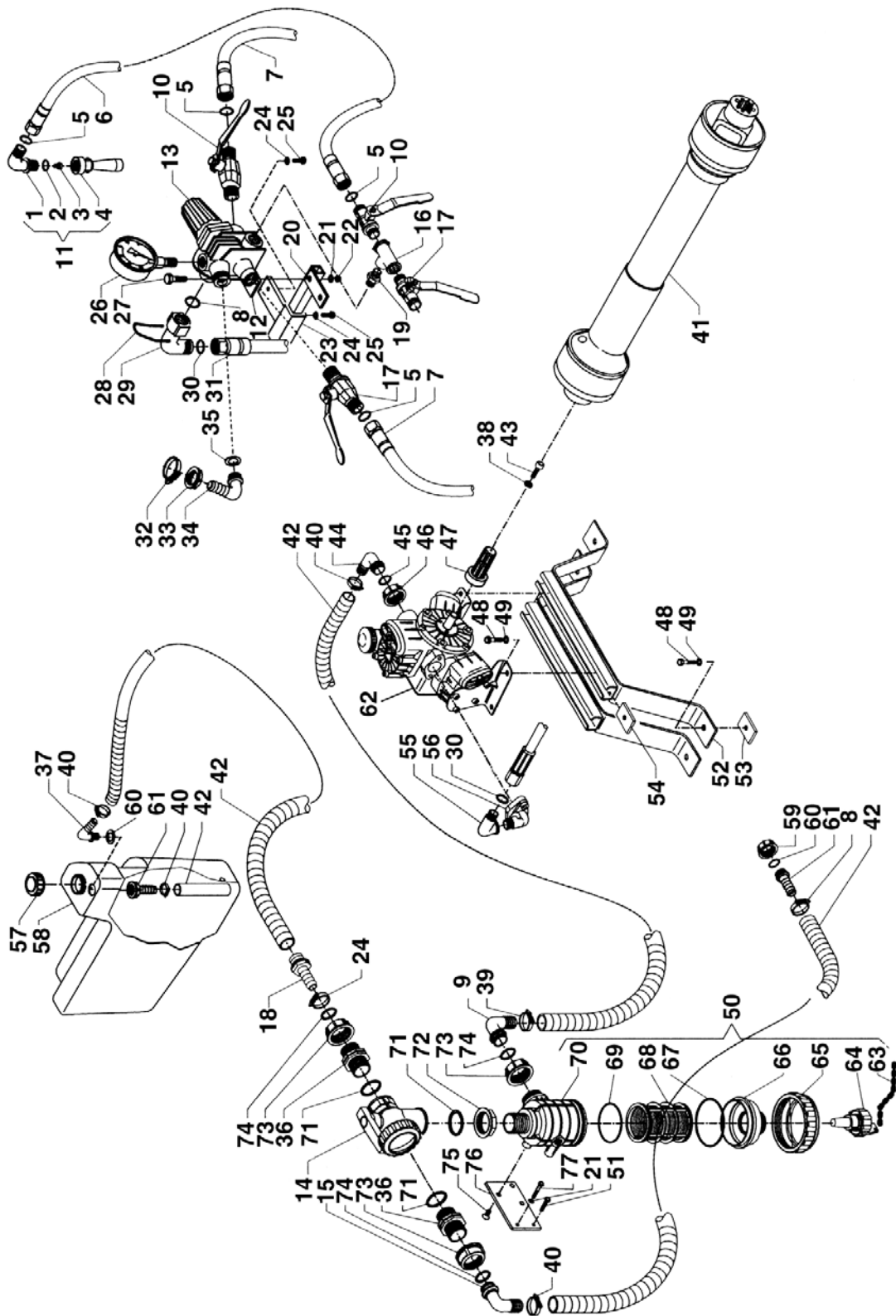

10 PARTS

10.4 For Run of Fluids - 100 & 150 Gallon

<u>REF #</u>	<u>QTY.</u>	<u>PART NO.</u>	<u>DESCRIPTION</u>
1	1	1400075	Elbow
2	1	1700006	O-Ring D.36 x 26 x 5
3	1	1400204	Nozzle D.1.5
4	1	1400074	Body
5	4	1700010	Gasket
6	1	1600690	Hose 10 x 19 L=1250
7	4	1600277	Hose 10 x 19 L=2350
8	3	OR1872262	O-Ring 18.72 x 2.62
9	1	1400049	Elbow D.30
10	2	130491	Ball Valve R.H.
11	1	1400210	Agitator Assembly
12	1	1150590	Bracket
13	1	RM40I	Regulator Valve
14	1	1400362	Ball Valve
15	1	00.483.000	Elbow D.30
16	1	1300035	Tee
17	2	130492	Ball Valve L.H.
18	1	1400048	Hose Barb D.30
19	1	1300034	Nipple 3/8"
20	1	0100235	Support
21	3	1800120	Washer M.8
22	2	1800180	Nut M8
23	1	0100236	Support
24	2	1800131	Washer 10 x 30 x 2.5
25	2	1800063	Bolt M10 x 20
26	1	550545	Gauge
27	2	1800021	Bolt M8 x 20
28	1	1040690	Clip
29	1	1040770	Fitting
30	2	1700025	O-Ring 22.2 x 16.2 x 3
31	1	1600688	Hose 13 x 23 L=1450
32	2	1500003	Clamp
33	1	550450	Ring Nut
34	1	550460	Elbow D.18
35	1	880830	O-Ring 15.54 x 16.62
36	2	1400149	Nipple 1 1/4"
37	1	1400167	Elbow D.30
38	1	961340	Washer D.8.5
39	1	1700051	O-Ring 31 x 2.5

Continued...

10 PARTS

10.4 For Run of Fluids - 100 & 150 Gallon

<u>REF #</u>	<u>QTY.</u>	<u>PART NO.</u>	<u>DESCRIPTION</u>
40	5	1500004	Clamp
41	1	7104056FFT077	Driveline
42	As Req'd	02.215.000	Hose 30 x 42 Per Foot
43	1	680350	Bolt M8 x 35
44	1	580040	Elbow D.30
45	1	OR293	O-Ring 29 x 3
46	1	580060	Ring Nut
47	1	1518	Adapter 25 mm
48	8	1800036	Bolt M10 x 25
49	8	1800130	Washer M10
50	1	1400197	Filter Assembly
51	1	1800056	Bolt M8 x 45
52	2	0101456	Support
53	4	0100107	Plate, Threaded
54	4	1040690	Lock Clip
55	1	1300019	Elbow, Brass
56	1	1040760	Fitting
57	1	0600187	Lid
58	1	0600167	Tank
59	1	1400024	Ring Nut
60	2	1700016	Gasket 45 x 33 x 3
61	2	1400129	Hose Barb D.30
62	1	AR503	Pump
63	1	1400007	Chain, Plastic L=300
64	1	1400205	Plug
65	1	1400206	Ring Nut
66	1	1400207	Cover
67	1	1400209	O-Ring 91.44 x 102.1 x 5.34
68	1	1400208	Strainer
69	2	OR7112262	O-Ring 71.12 x 2.62
70	1	1400210	Body
71	3	OR3747533	O-Ring 37.47 x 5.33
72	1	1400009	Ring Nut
73	3	1400013	Ring Nut
74	3	OR2664262	O-Ring 26.64 x 2.62
75	3	1800447	Bolt M8 x 16
76	1	0101475	Plate, Support
77	1	1800039	Bolt M8 x 50

10.5 Fan Assembly

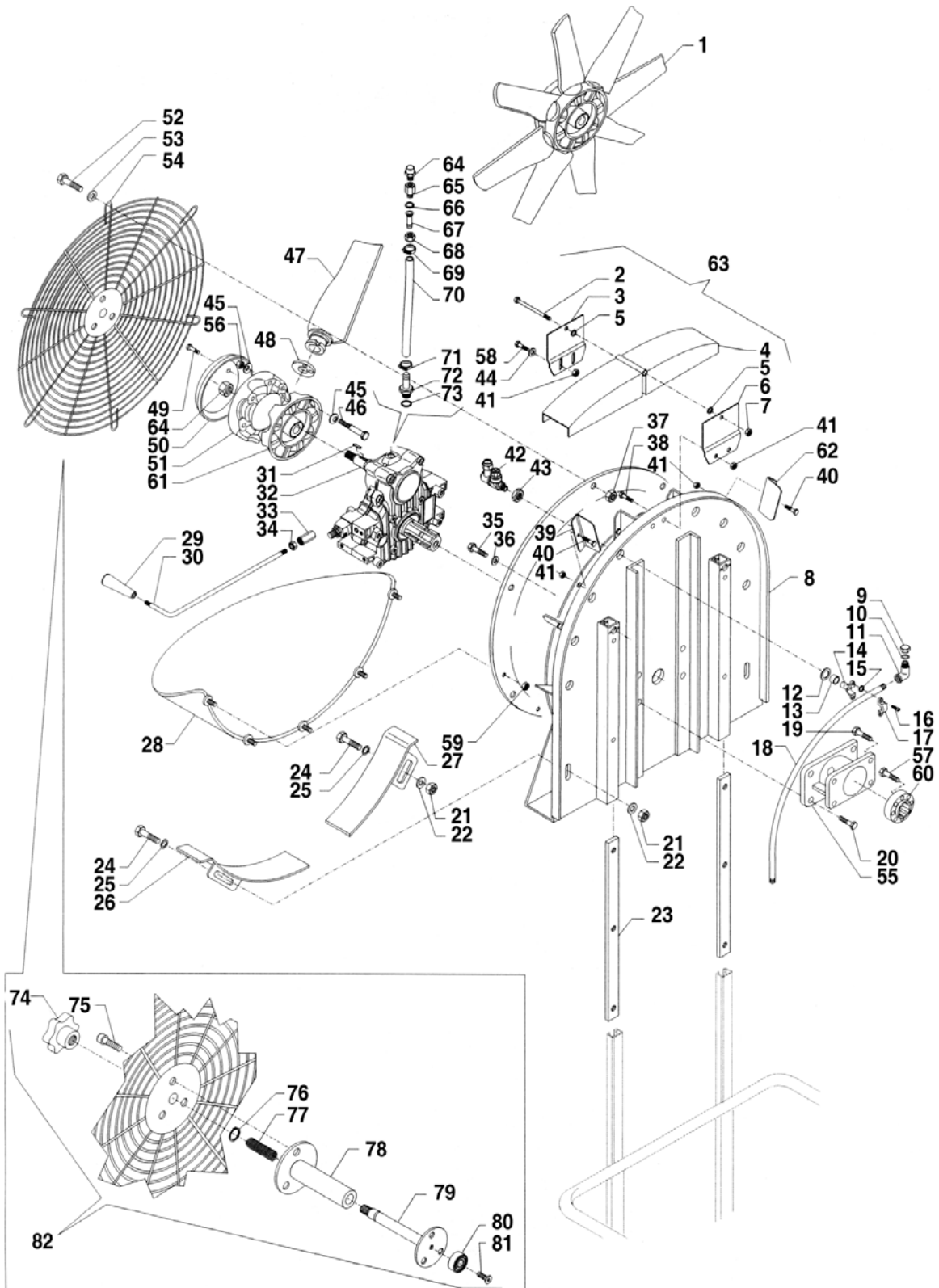

10

PARTS

10.5 Fan Assembly

<u>REF #</u>	<u>QTY.</u>	<u>PART NO.</u>	<u>DESCRIPTION</u>
1	1	0100619	Fan D.700, 100 & 150 Gallon
1	1	0101093	Fan D.600, 50 Gallon
2	1	1800136	Bolt M8 x 100
3	1	0101485	Front Plate 50 Gallon
3	1	0101468	Front Plate 100 & 150 Gallon
4	2	0101465	Shield
5	2	1800120	Washer M8
6	1	0101467	Rear Plate
7	7	1800181	Nut M8
8	1	0100614	Support
9	2	0100097	Blind Plug
10	2	1700021	Gasket 19 x 4
11	2	1300001	Elbow, Brass
12	4	1800150	Washer M14
13	4	0101034	Bushing 19.2 x 27 x 11
14	8	0800003	Body, 50 Gallon
14	10	0800003	Body, 100 & 150 Gallon
15	8	OR992262	O-Ring 9.92 x 2.62, 50 Gallon
15	10	OR992262	O-Ring 9.92 x 2.62, 100 & 150 Gallon
16	16	1800002	Bolt M5 x 16, 50 Gallon
16	20	1800002	Bolt M5 x 16, 100 & 150 Gallon
17	8	0800004	Nozzle Clamp, 50 Gallon
17	10	0800004	Nozzle Clamp, 100 & 150 Gallon
18	2	2000031	Tube, D.20 x 1.2, 50 Gallon
18	2	2000049	Tube, D.20 x 1.2, 100 & 150 Gallon
19	6	1800036	Bolt M10 x 25
20	4	1800038	Bolt M10 x 35
21	2	1800185	Nut M10
22	12	1800130	Washer M10
23	2	0101486	Support Plate L=560 50 Gallon
23	2	0101466	Support Plate L=770 100 & 150 Gallon
24	2	1800036	Bolt M10 x 25
25	4	1800130	Washer M10
26	1	0100264	Fin R. H.
27	1	0100265	Fin L. H.
28	1	1400237	Trash Shield
29	1	1800413	Knob
30	1	0100618	Lever
31	1	1800417	Key 6 x 6 x 30
32	1	0300099	Gearbox
33	1	0100253	Bushing D.12 x 30
34	1	1800190	Nut M12
35	4	1800042	Bolt M10 x 55
36	4	1800130	Washer M10
37	5	1800179	Nut M6
38	10	1800021	Bolt M8 x 20
39	4	0101469	Side Fin R.H.
40	8	1800021	Bolt M8 x 20

Continued....

10.5 Fan Assembly

<u>REF #</u>	<u>QTY.</u>	<u>PART NO.</u>	<u>DESCRIPTION</u>
41	8	1800181	Nut M8
42	10	0800305	Nozzle Assy (For exploded view, see Pg. 25)
43	8	0800031	Nut 1/4"
44	2	1800122	Washer 8 x 24
45	8	1800114	Washer 6 x 18
46	8	1800051	Bolt M6 x 35
47	8	0101094	Blade Fan 50 Gallon
47	8	0100620	Blade Fan 100 & 150 Gallon
48	8	0100080	Insert 20 Degrees
48	8	0100081	Insert 25 Degrees (Option)
48	8	0100082	Insert 30 Degrees (Option)
48	8	0100083	Insert 35 Degrees (Option)
48	8	0100084	Insert 40 Degrees (Option)
49	2	1800146	Bolt M5 x 25
50	1	0100739	Cover, Clutch
51	1	0100824	Clutch Assembly
52	5	1800013	Bolt M6 x 20
53	5	1800014	Washer M6
54	1	0100776	Grill 50 Gallon
54	1	0100333	Grill 100 & 150 Gallon
55	1	0200478	Flange
56	1	1800184	Nut M6
57	6	1800037	Bolt M10 x 30
58	2	1800021	Bolt M8 x 20
59	5	1800180	Nut M8
60	1	AR620250	Bushing
61	1	0100825	Hub
62	4	0101470	Side Fin L.H.
63	1	2700030	Complete Fin Assembly
64	1	0300019	Plug
65	1	1300158	Valve Extension
66	2	1700022	Gasket 10.5 x 15 x 2
67	1	0101697	Hose Tail D.10
68	1	0800071	Ring Nut Nozzle
69	2	1500036	Clamp 10 x 16
70	1	1600727	Hose 10 x 17 L=450
71	2	1500036	Clamp 10 x 16
72	2	1300189	Hose Connector
73	1	1700019	O-Ring 130 x 123 x 3.5
74	1	1800374	Wheel D.40 M10
75	3	1800352	Bolt M6 x 16
76	1	1800373	Circlip E10
77	1	2500017	Spring
78	1	0101720	Support Male Shaft Fan
79	1	0101721	Support Female Shaft Fan
80	1	1400420	Rubber Plug
81	1	1800435	Bolt M6 x 16
82	1	A000205	Shaft Fan Kit

10.6 Gearbox Assembly

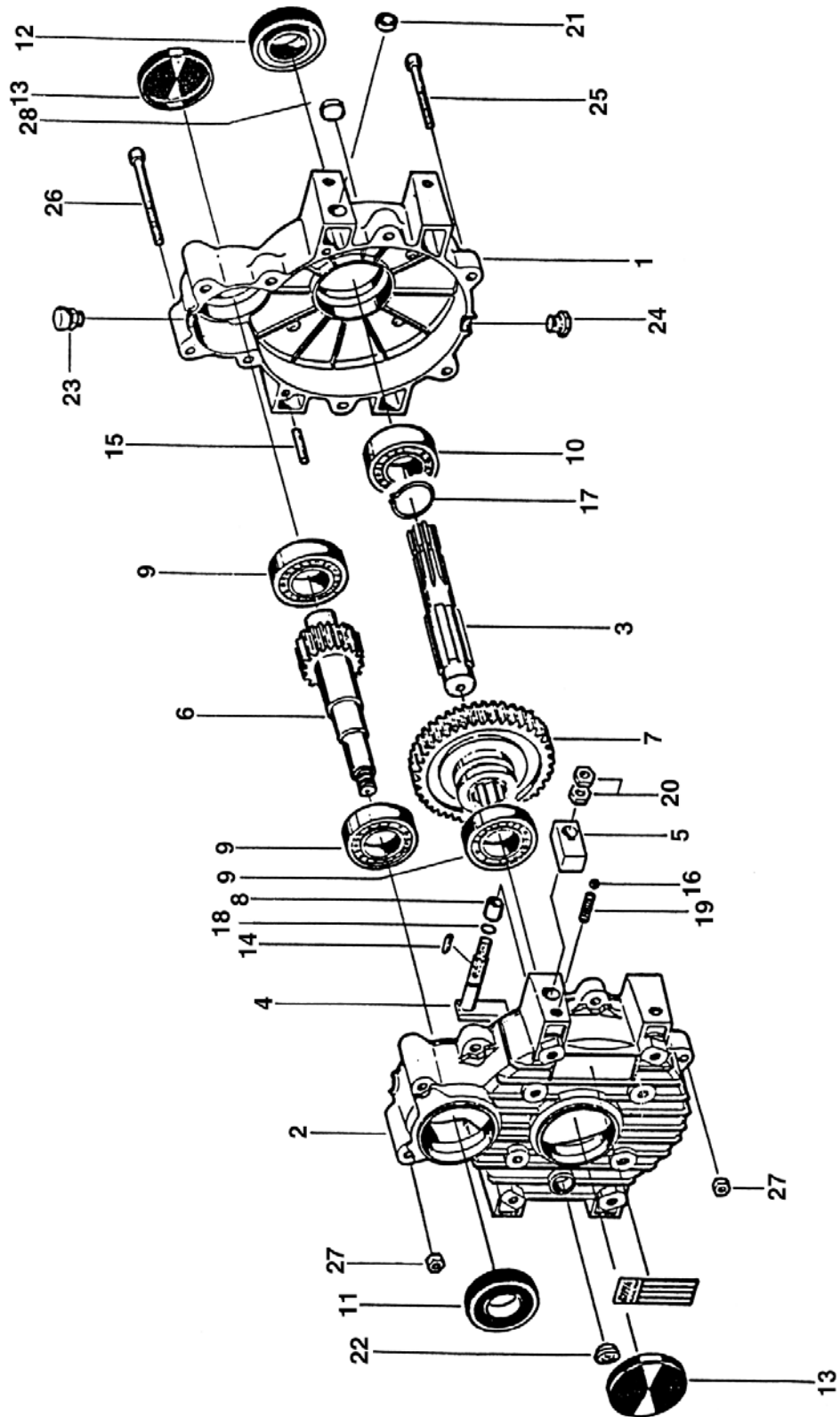

10

PARTS

10.6 Gearbox Assembly

<u>REF #</u>	<u>QTY.</u>	<u>PART NO.</u>	<u>DESCRIPTION</u>
1	1	0300165	Entrance Body Car
2	1	0300166	Exit Body Car
3	1	0300167	Entrance Shaft
4	1	0300168	Lever
5	1	0300169	Lever Support
6	1	0300171	Exit Shaft Car
7	1	0300061	Gear
8	1	0300172	Spacer
9	3	6305	Bearing 25 x 62 x 17
10	1	6206	Bearing 30 x 62 x 16
11	1	25X52X7	Oil Seal
12	1	35X52X7	Oil Seal
13	2	0300170	Shaft Cover
14	1	1800423	Key A 5 x 5 x 15
15	4	1800319	Elastic Pin 8 x 20
16	1	0300139	Ball 5/16"
17	1	47130	Circlip E30
18	1	0300066	O-Ring
19	1	0300173	Spring
20	2	1800190	Nut M12
21	1	0300174	Lateral Plug
22	1	0300141	Level Plug SLP20
23	1	0300017	Plug 3/8
24	1	0300063	Blind Plug 3/8" Gas
25	6	1800106	Bolt TCEI M8 x 40
26	2	1800107	Bolt TCEI M8 x 90
27	8	1800180	Nut M8
28	1	0300175	Plug

10.7 Pump Assembly For APL200

AR403

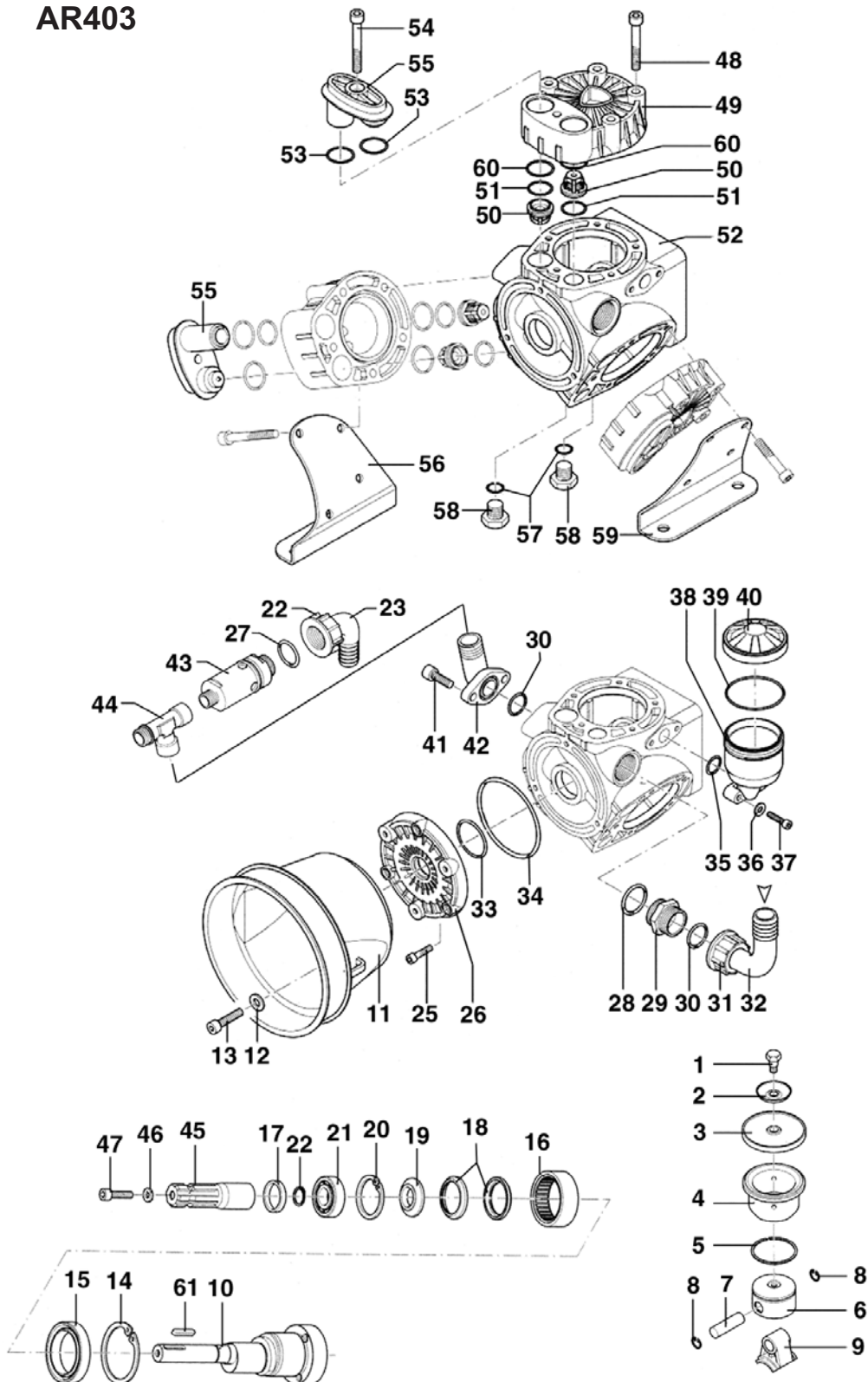

10 PARTS

10.7 Pump Assembly For APL200

<u>REF #</u>	<u>QTY.</u>	<u>PART NO.</u>	<u>DESCRIPTION</u>
1	3	800090	Pin, Diaphragm
2	3	800350	Washer, Cup
3	1	2387	Diaphragm Kit
4	3	1880050	Sleeve
5	3	1880110	Piston Ring
6	3	1880060	Piston
7	3	1880120	Pin, Piston
8	6	380080	Circlip, Piston
9	3	1880070	Rod, Connecting
10	1	1880160	Crankshaft
11	1	1500350	Shield
12	3	380241	Washer D.8.5
13	3	850250	Bolt M10 x 16
14	1	620330	Circlip
15	1	50X65X8	Oil Seal
16	1	DHK5020	Bearing
17	1	1880190	Seal Ring
18	2	1880180	Ring
19	1	1880170	Spacer
20	1	47247	Circlip I47
21	1	1461430	Bearing
22	1	47120	Circlip E20
23	1	550460	Elbow
24	1	550450	Nut
25	3	780060	Bolt M6 x 25
26	1	1880021	Manifold
27	1	880831	O-Ring 15.54 x 2.62
* 28	1	OR293	O-Ring 29 x 3
29	1	550340	Nipple 1"
* 30	2	550350	O-Ring 23.81 x 2.62
31	1	550242	Nut
32	1	550370	Elbow
* 33	1	390201	O-Ring
* 34	1	1880130	O-Ring
* 35	1	OR1872262	O-Ring 18.72 x 2.62
36	2	550331	Washer D.6.5
37	2	1200440	Bolt M6 x 30
38	1	1040310	Tank, Oil
* 39	1	650920	O-Ring

Continued...

10

PARTS

10.7 Pump Assembly For APL200

<u>REF #</u>	<u>QTY.</u>	<u>PART NO.</u>	<u>DESCRIPTION</u>
40	1	1040320	Cap
41	2	540290	Bolt M8 x 25
42	1	450145	Flange
43	1	1433	Relief Valve
44	1	1620450	Tee
45	1	621370	PTO Adapter
46	1	961340	Washer
47	1	680350	Bolt M8 x 35
48	1	800860	Bolt M8 x 55
49	3	1880030	Head
50	1	2388	Check Valve Kit (with O-Rings Ref. #51)
* 51	9	1140450	O-Ring 20.24 x 2.62
52	1	1880010	Housing
* 53	6	OR2670178	O-Ring 26.7 x 1.78
54	3	280080	Bolt M8 x 60
55	3	1880040	Cover
56	1	1880090	Bracket L.H.
* 57	2	OR14178	O-Ring 14.1 x 1.78
58	2	880530	Plug
59	1	1880080	Bracket R.H.
60	6	780050	O-Ring 28.25 x 1.78
61	1	620680	Tempered Key 6 x 6 x 30

□KIT 1922		θ KIT 1757			
REF.	QTY.	REF.	QTY.	REF.	QTY.
11	5	5	1	13	1
		10	1	14	1
		11	1		
		12	1		

10 PARTS

10.8 Pump Assembly

AR503

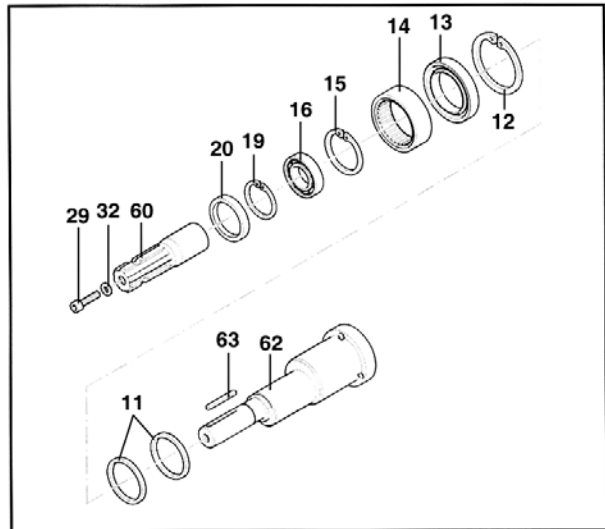
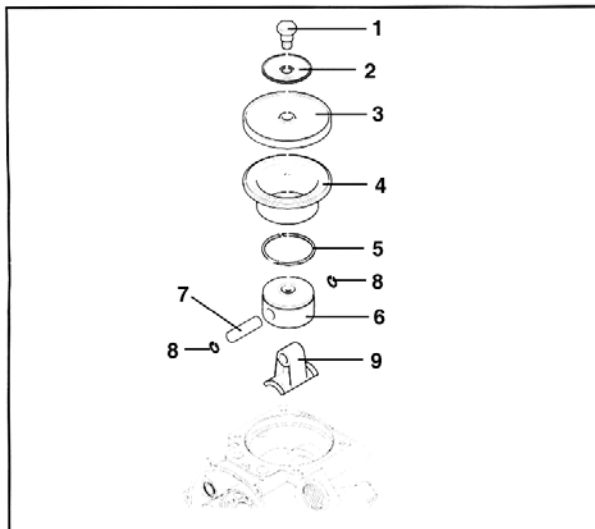
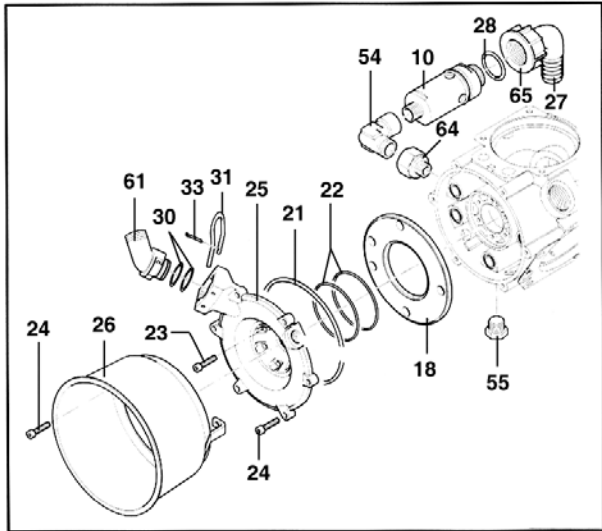
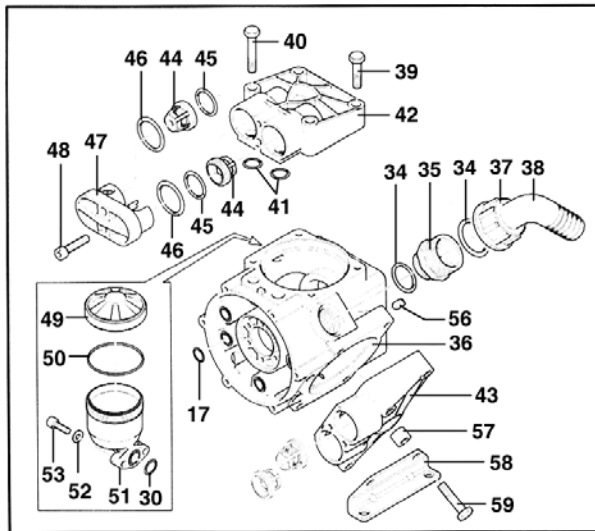

10

PARTS

10.8 Pump Assembly

<u>REF #</u>	<u>QTY.</u>	<u>PART NO.</u>	<u>DESCRIPTION</u>
1	3	580360	Bolt
2	3	1040180	Retaining Washer
3	1	1986	Diaphragm Kit
3	3	620081	Diaphragm Viton (optional)
4	3	1300110	Sleeve
5	3	160230	Piston Ring
6	3	620120	Piston
7	3	380300	Pin, Connecting Rod
8	6	380080	Retainer Ring
9	3	1300140	Connecting Rod
10	1	1433	Relief Valve
11	2	1300120	Retainer Ring
12	1	47270	Circlip I70
13	1	55X70X8	Oil Seal
14	1	HK5520	Bearing
15	1	47252	Circlip I52
16	1	6205	Bearing
⊕ 17	5	OR14178	O-Ring 14 x 1.78
18	1	1300020	Manifold Plate
19	1	47125	Circlip E25
20	1	25X35X7	Oil Seal
⊕ 21	1	1300270	O-Ring 126.67 x 2.62
⊕ 22	2	OR60262	O-Ring 60 x 2.62
23	6	880280	Bolt M6 x 18
24	6	1040370	Bolt M6 x 22
25	1	1300030	Discharge Manifold
26	1	1500130	Shield, PTO
27	1	00.055.046	90 Degree Elbow D.18
28	1	OR1588262	O-Ring 15.54 x 2.62
29	1	680350	Bolt M8 x 35
⊕ 30	3	OR1872262	O-Ring 18.72 x 2.62
31	1	1040690	Clip
32	1	961340	Washer D.8.5
33	1	1040950	Cotter Pin
⊕ 34	2	OR293	O-Ring 29 x 3
35	1	450120	Adapter 1" - 1 1/4"
36	1	1300010	Housing, Pump
37	1	580060	Nut 1 1/4
38	1	580040	90 Degree Elbow D.30
39	4	200230	Bolt M10 x 45
40	4	640230	Bolt M10 x 60

10.8 Pump Assembly

<u>REF #</u>	<u>QTY.</u>	<u>PART NO.</u>	<u>DESCRIPTION</u>
⊕ 41	6	OR1713262	O-Ring 17.13 x 2.62
42	2	1300101	Head, Pump R.H.
43	1	1300102	Head, Pump L.H.
44	1	1987	Valve Kit (includes Ref. #45 & 46)
⊕ 45	6	OR2580353	O-Ring 25.80 x 3.53
⊕ 46	6	OR3305178	O-Ring 33.05 x 1.78
47	3	1300190	Valve Head
48	6	620610	Bolt M8 x 30
49	1	1040322	Cap, Oil Bowl
⊕ 50	1	OR5364262	O-Ring 53.64 x 2.62
51	1	1040310	Oil Bowl
52	2	550331	Washer D.6.5
53	2	850850	Bolt M6 x 30
54	1	881560	Elbow
55	1	880530	Plug
56	1	770070	Plug, Allen Head
57	2	1300280	Spacer
58	2	1300090	Mount Bracket
59	4	1300360	Bolt M10 x 65
60	1	1518	PTO Adapter
61	1	1040760	Adapter
62	1	1300160	Crankshaft
63	1	650250	Key
64	1	881461	Adapter

⊕KIT 1984 O-RING KIT	
REF.	QTY.
17	6
21	1
22	2
30	3
34	2
41	6
45	6
46	6
50	1

10 PARTS

10.9 Valve Assembly

RM40S

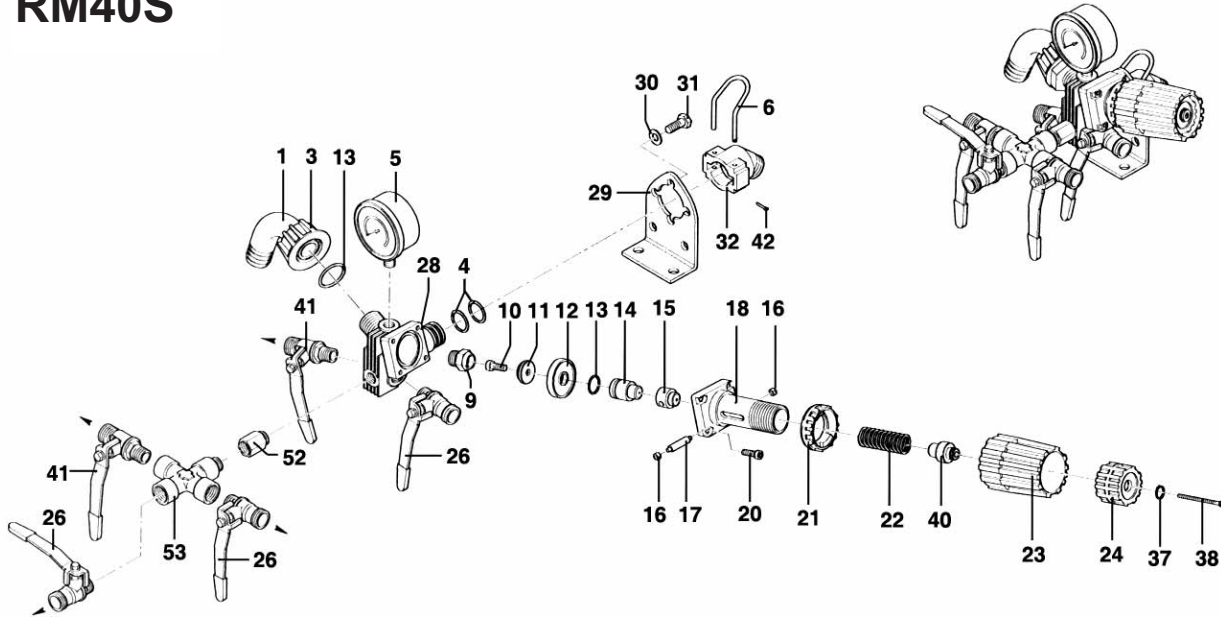

<u>REF #</u>	<u>QTY.</u>	<u>PART NO.</u>	<u>DESCRIPTION</u>
1	1	550460	Elbow 18
3	1	550450	Nut Plastic 3/4" GAS
Δ ● 4	7	390180	O-Ring 3075 18.72 x 2.62
5	1	550545	Pressure Gauge
● 6	1	1040690	Lockclip
● 9	1	1150520	Valve Seat
10	1	680560	Bolt, 6 x 15 Allen
● 11	1	1040640	Valve Seat
● 12	1	1040631	Diaphragm
Δ ● 13	2	1988	O-Ring 3062 15.54 x 2.62
14	1	1040620	Piston
● 15	1	1150560	Spacer
16	2	1150600	Bushing
● 17	1	1150540	Roll Pin
18	1	1150510	Valve Body
20	4	780330	Bolt, 6 x 20 Allen
● 21	1	1150530	Control Nut
● 22	1	394760	Spring

10

PARTS

10.9 Valve Assembly

<u>REF #</u>	<u>QTY.</u>	<u>PART NO.</u>	<u>DESCRIPTION</u>
●23	1	1150550	Control Knob
●24	1	1150570	Control Knob
26	3	130491	Ball Valve 3/8
28	1	1150500	Valve Body
29	1	1150590	Mounting Bracket
30	2	390311	Washer 8.5
31	2	180431	Bolt, 8 x 16
32	1	1040770	Fitting Pressure
37	1	480550	Circlip
38	1	1150650	Allen Bolt M3 x 60
40	1	1150660	Spacer
41	2	130492	Left Valve
42	1	1040950	Split Pin
52	1	1041210	Extension
53	1	1041220	Adapter

△ KIT 1988 O-RING		● KIT 1989 VALVE			
REF.	QTY.	REF.	QTY.	REF.	QTY.
390180	7	390180	4	1150530	1
880830	2	394760	1	1150540	1
		480550	1	1150550	1
		880830	1	1150560	1
		1040630	1	1150570	1
		1040640	1	1150650	1
		1040690	1	1150660	1
		1150520	1		

10 PARTS

10.10 Nozzle Assembly

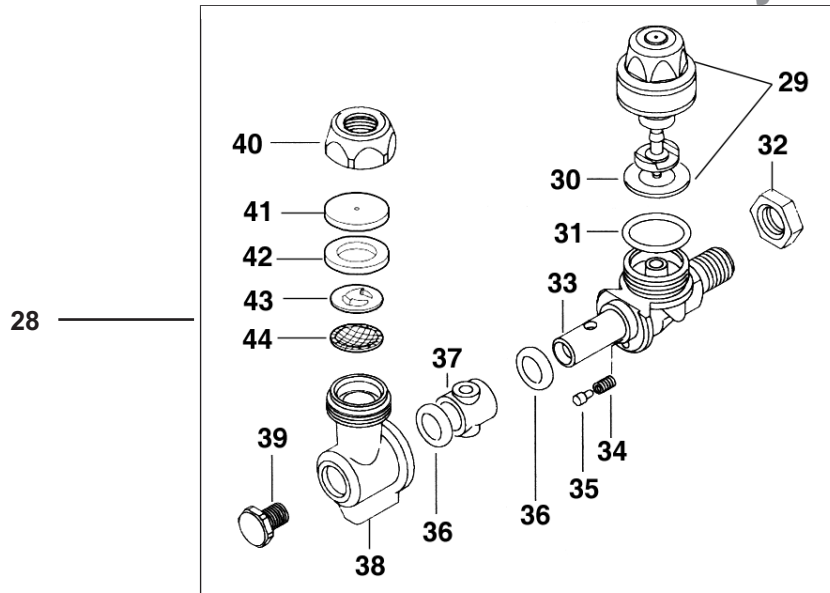

<u>REF #</u>	<u>QTY.</u>	<u>PART NO.</u>	<u>DESCRIPTION</u>
28	8	0800293	Nozzle Assembly
29	1	75.1007.8	Anti-drip Assembly
30	1	300.1006.3	Diaphragm
31	1	75.602.40	O-Ring
32	1	75.301.23	Nut 3/8" BSP GAS
33	1	75.208.126	Body
34	1	75.1003.23	Spring
35	1	75.507.9	Screw
36	2	73.602.22	Gasket
37	1	73.209.1	Slip Body
38	1	76.107.15	Adjustable Body 018 (includes #62)
39	1	75.1902.24	End Screw
40	1	75.605.47	Nut 018
41	1	0800327	Ceramic Disc .8 - 15 mm Digmate
41	1	0800323	Ceramic Disc 1.0 - 15 mm Digmate
41	1	0800326	Ceramic Disc 1.2 - 15 mm Digmate
41	1	0800324	Ceramic Disc 1.5 - 15 mm Digmate
41	1	0800357	Ceramic Disc 1.8 - 15 mm Digmate
41	1	0800358	Ceramic Disc 2.0 - 15 mm Digmate
41	1	0800359	Ceramic Disc 2.3 - 15 mm Digmate
42	1	OR1078262	O-Ring
43	1	0800325	Swirl Plate Blind
43	1	0800360	Swirl Plate 1.2
43	1	0800361	Swirl Plate 1.5
43	1	0800362	Swirl Plate 1.8
44	1	02.311.010	Screen

10

PARTS

10.11 Driveline Assembly 7104056FFT077

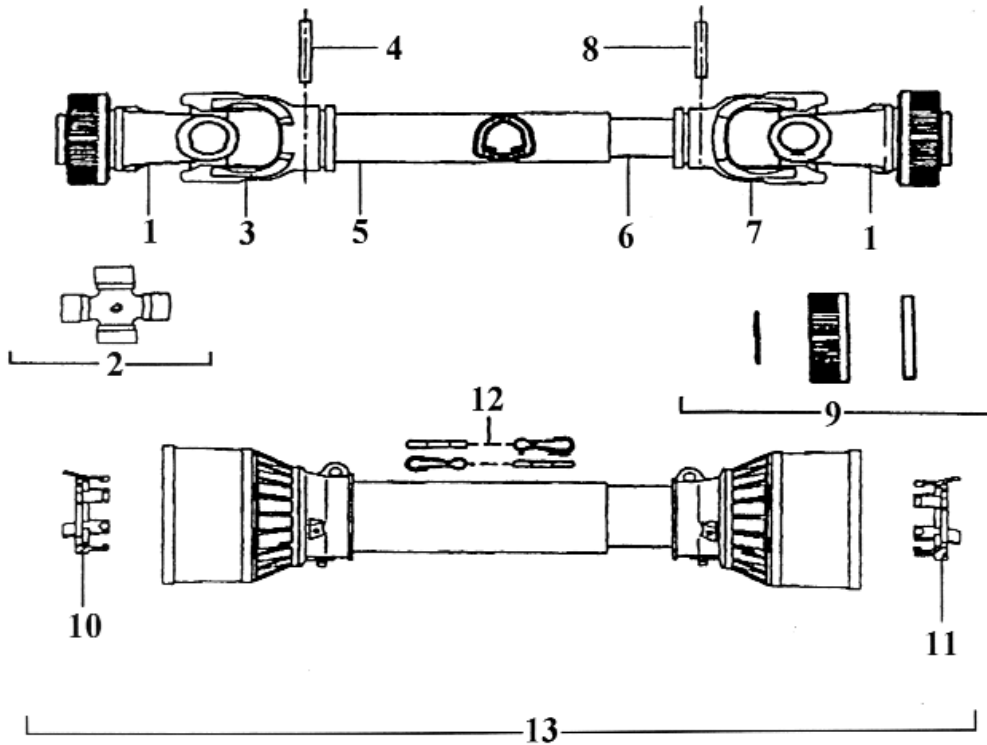

<u>REF #</u>	<u>QTY.</u>	<u>PART NO.</u>	<u>DESCRIPTION</u>
1	2	572040351	RS Yoke 1 3/8 6 Spline
2	2	41204R	#4 Cross Kit
3	1	204046851	Outer Tube Yoke
4	1	341038000	Roll Pin O.T.
5	1	225120860	Outer Drive Tube 860 mm
6	1	225100860	Inner Drive Tube 860 mm
7	1	204046852	Inner Tube Yoke
8	1	341048000	Roll Pin I.T.
9	2	240002451	RS Collar Kit
10	1	255040005	Shield Bearing Outer
11	1	255040006	Shield Bearing Inner
12	2	252000001	Safety Chain
13	1	5F04086F6	Complete Shield w/Bearings

10.12 Optional Tommy Gun (GHT)

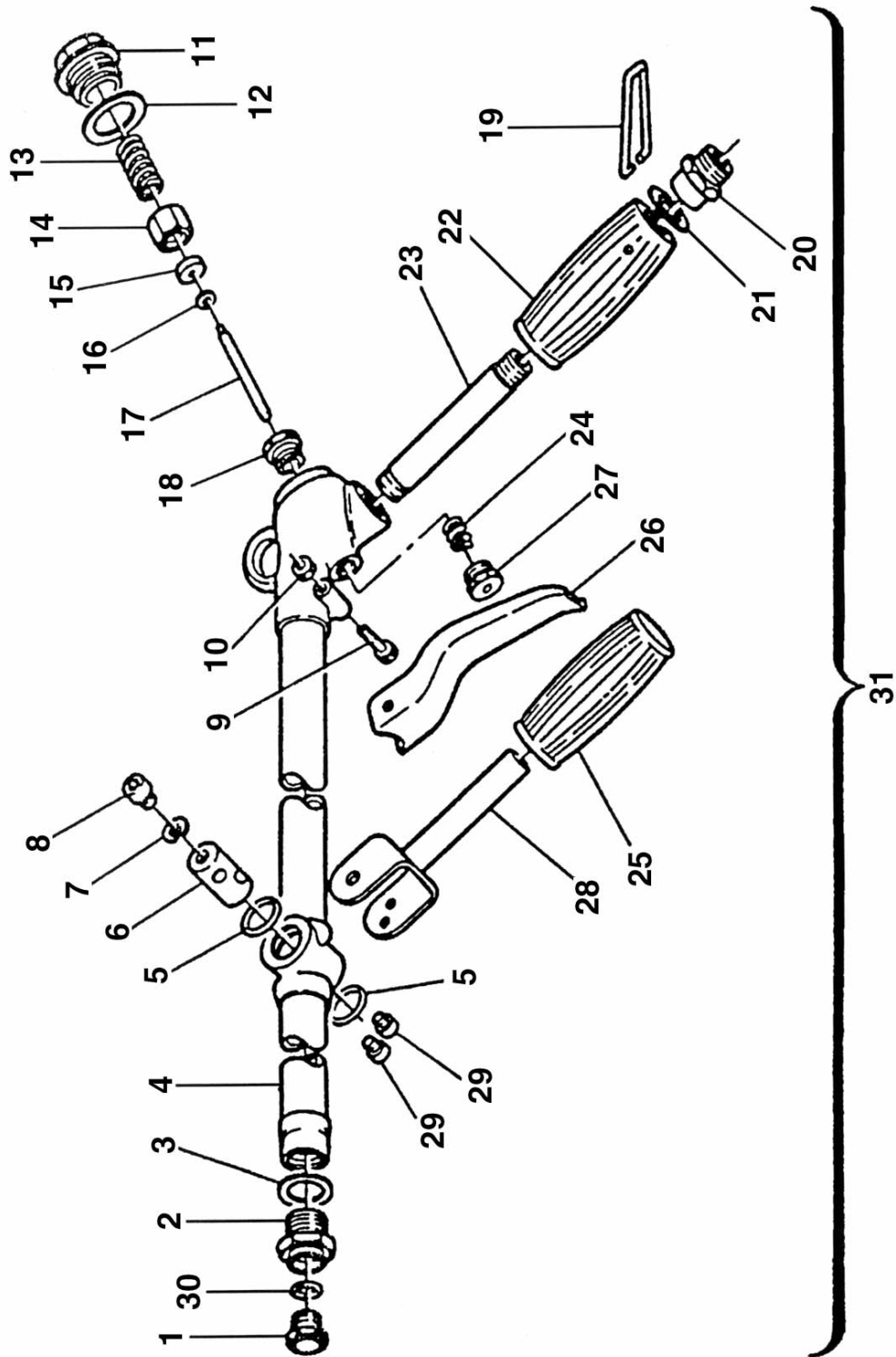

10 PARTS

10.12 Optional Tommy Gun (GHT)

<u>REF #</u>	<u>QTY.</u>	<u>PART NO.</u>	<u>DESCRIPTION</u>
1	1	0800080	Nozzle 1.5
1	1	0800081	Nozzle 1.8
1	1	0800082	Nozzle 2.0
1	1	0800083	Nozzle 2.8
1	1	0800084	Nozzle 3.0
1	1	0800085	Nozzle 3.5
2	1	0800086	Jet Support
3	1	0800087	Gasket
4	1	0800088	Body
5	2	0800089	Gasket
6	1	0800090	Bushing
7	1	0800091	Washer
8	1	0800092	Bolt
9	1	0800093	Bolt
10	1	0800094	Nut
11	1	0800095	Plug
12	1	0800096	Gasket
13	1	0800097	Spring
14	1	0800098	Nut
15	1	0800099	Washer
16	1	0800100	Washer
17	1	0800101	Pin
18	1	0800102	Nut
19	1	0800103	Spring
20	1	0800104	Plug
21	1	0800105	Gasket
22	1	0800106	Handle
23	1	0800107	Shaft
24	1	0800108	Gasket
25	1	0800109	Handle
26	1	0800110	Lever
27	1	0800111	Plug
28	1	0800112	Fork
29	2	0800113	Bolt
30	1	0800114	Gasket
31	1	GHT	Complete Handgun

10.13 Optional Electric Controls

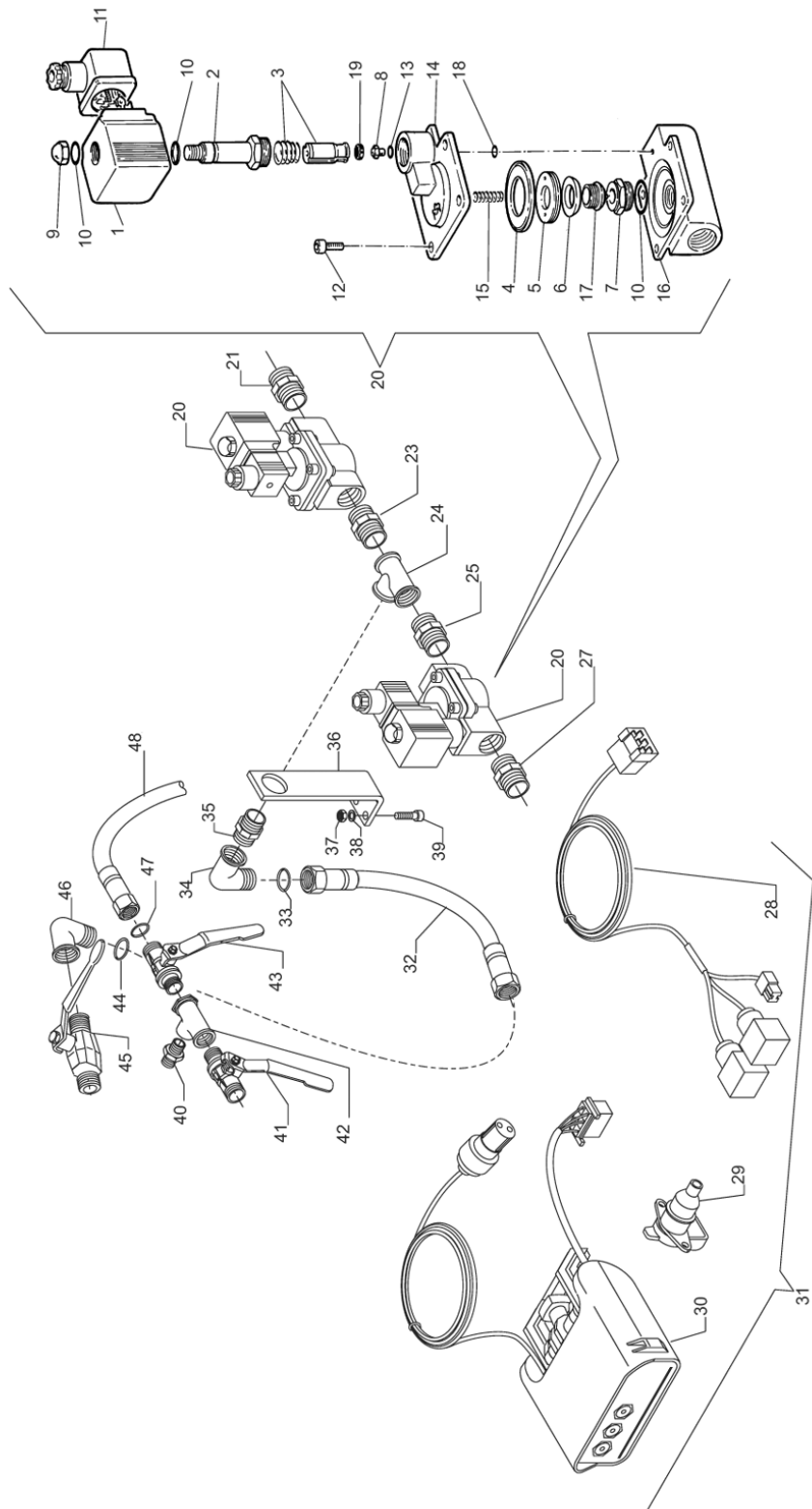

10

PARTS

10.13 Optional Electric Controls

<u>REF #</u>	<u>QTY.</u>	<u>PART NO.</u>	<u>DESCRIPTION</u>
1	1	OCLR73-952	Complete Coil
2	1	OCLR73-953	Fixed Core
3	1	OCLR73-954	Mobile Core
4	1	OCLR73-957	Viton Membrane
5	1	OCLR73-958	Plate
6	1	OCLR73-958A	Taper Gasket
7	1	OCLR73-959	Stainless Steel Seat
8	1	OCLR73-955	Nozzle
9	1	OCLR73-951	Cap Nut
10	1	OCLR73-709	O-Ring 2056
11	1	OCLR73-950	Connector
12	1	OCLR59-711	Screw
13	1	OCLR25-471	O-Ring 104
14	1	OCLR73-956	Cap
15	1	OCLR58-542	Spring for Anti-Drip
16	1	OCLR73-960	Body
17	1	OCLR73-961	Screw
18	1	OCLR1-2015	Ring OR 2015
19	1	OCLR73-954A	Gasket
20	2	0800285	Solenoid Electric Valve
21	1	1300021	Brass Nipple 1/2-1/2
23	1	1300021	Brass Nipple 1/2-1/2
24	1	1300106	Connector
25	1	1300021	Brass Nipple 1/2-1/2
27	1	1300021	Brass Nipple 1/2-1/2
29	1	SA-905048	Feeding Socket
31	1	0200017	Box Plt OCLL 2A+G Saver Pump C/C Masotti
32	1	1600303	Hose 10 x 19 80 Bar L=300 RA
33	1	1700010	Gasket 18 x 12 x 2 White
34	1	1300001	Brass Elbow MF 1/2-1/2
35	1	1300021	Brass Nipple 1/2-1/2
36	1	0101751	Support Electric Command
37	2	1800180	Nut M8 UNI 5587 6.8 Galvanized
38	2	1800120	Flat Washer UNI 6592 M.8 Galvanized
39	2	1800018	Bolt TCEI M8 x 20 UNI 5931 8.8 Galvanized
40	1	1300034	Nipple MM 3/8-3/8
41	1	1300010	Valve LH 1/2-5/8 A.5264
42	1	1300035	Connector 3/8-3/8-3/8
43	1	1300009	Cock RH 1/2-3/8 "Meteor" A.5263
44	1	1700010	Gasket 18 x 12 x 2 White
45	1	1300009	Cock RH 1/2-3/8 "Meteor" A.5263
46	1	1300001	Brass Elbow MF 1/2-1/2
47	1	1700010	Gasket 18 x 12 x 2 White
48	1	1600690	Hose Co. PVC 10 x 19 80 Bar L=1250

Limited Warranty



GEARMORE, INC., warrants each new Gearmore product to be free from defects in material and workmanship for a period of twelve (12) months from date of purchase to the original purchaser. This warranty shall not apply to implements or parts that have been subject to misuse, negligence, accident, or that have been altered in any way.

Our obligation shall be limited to repairing or replacement of any part, provided that such part is returned within thirty (30) days from date of failure to Gearmore through the dealer from whom the purchase was made, transportation charges prepaid.

This warranty shall not be interpreted to render us liable for injury or damages of any kind or nature, direct, consequential or contingent, to person or property. This warranty does not extend to loss of crops, loss because of delay in harvesting or any other expenses, for any other reasons.

Gearmore in no way warrants engines, tires, or other trade accessories, since these items are warranted separately by these respective manufacturers.

Gearmore reserves the right to make improvements in design or changes in specification at any time, without incurring any obligations to owners or units previously sold.

GEARMORE, INC.
13477 Benson Ave.
Chino, CA 91710

Always refer to and heed machine operating warning decals on machine.

*To validate the warranty on this product,
please go to our website - www.gearmore.com.
You will find "Warranty Registration"
listed at the top of our home page.*